

SOUND 2W MONO AMPLIFIER

- CAN DELIVER 2W THD 10% 12V/8Ω
- INTERNAL FIXED GAIN 20dB
- NO BOUCHEROT CELL
- THERMAL PROTECTION
- AC SHORT CIRCUIT PROTECTION
- SVR CAPACITOR FOR BETTER RIPPLEREJECTION
- LOW TURN-ON/OFF POP
- STAND-BY MODE

DESCRIPTION

The device TDA7299 is a new technology Mono Audio Amplifier in SO package specially designed for 12V sound cards application.

Thanks to the fully complementary output configura-



tion the device delivers a rail voltage swing without need of bootstrap capacitors.

BLOCK DIAGRAM

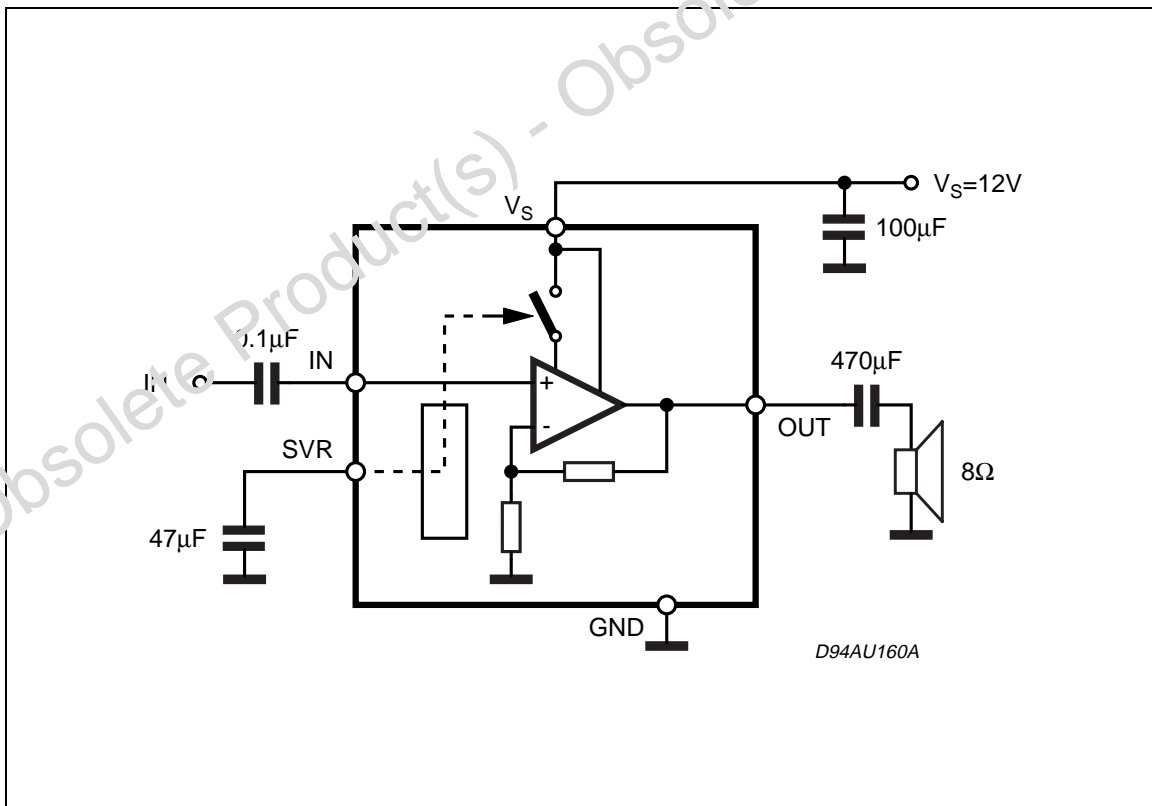

TDA7299

ABSOLUTE MAXIMUM RATINGS

Symbol	Parameter	Value	Unit
V_S	Operating Supply Voltage	18	V
I_O	Output Put Peak Current	1.5	A
T_{op}	Operating Temperature Range	0 to 70	°C
T_j	Junction Temperature	150	°C
T_{stg}	Storage Temperature Range	-40 to 125	°C

PIN CONNECTION (Top view)

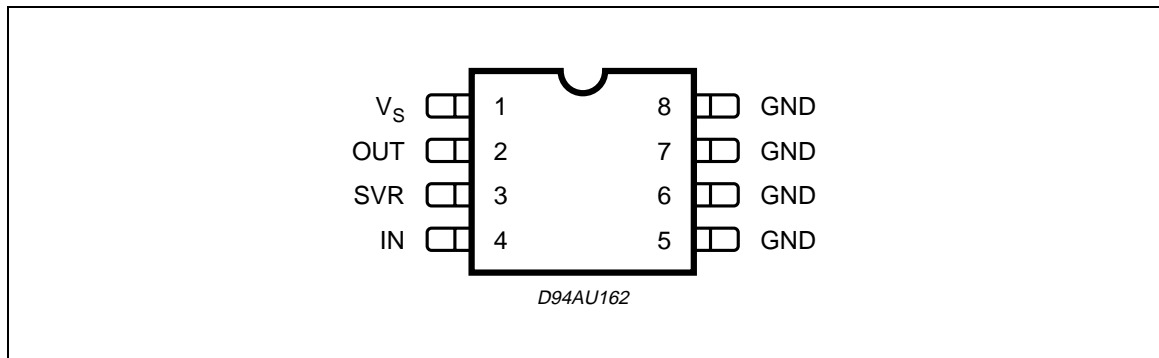

THERMAL DATA

Symbol	Parameter	Value	Unit
$R_{th\ j-amb}$	Thermal Resistance Junction to ambient (on PCB)	80	°C/W
$R_{th\ j-case}$	Thermal Resistance Junction to case	20	°C/W

ELECTRICAL CHARACTERISTICS

($T_{amb} = 25^{\circ}\text{C}$; $V_S = 12\text{V}$; $R_L = 8\Omega$; $f = 1\text{KHz}$; unless otherwise specified.)

Symbol	Parameter	Test Condition	Min.	Typ.	Max.	Unit
V_S	Supply Voltage Range		4.5		18	V
I_S	Quiescent Current			20	30	mA
I_{sb}	Stand-By Current	Pin 2 shorted to GND			0.3	mA
V_O	Quiescent Output Voltage			6		V
A_V	Voltage Gain			20		dB
R_{IN}	Input Impedance		50	100		K Ω
P_O	Output Power	THD = 10%	1.8	2		W
		$R_L = 4\Omega$, $V_S = 8.5\text{V}$, THD = 10%		2		W

ELECTRICAL CHARACTERISTICS (continued)(T_{amb} = 25°C; V_S = 12V; R_L = 8Ω; f = 1KHz; unless otherwise specified.)

Symbol	Parameter	Test Condition	Min.	Typ.	Max.	Unit
P _{ot}	Transient Output Power *)	V _i = 400mVp, THD < 2%, R _L = 4Ω		2		W
THD	Distortion	P _O = 1W			1	%
SVR	Supply Voltage Rejection	V _{ripple} = 150mVrms; F _{ripple} = 1KHz		50		dB
E _I	Input Noise Voltage	R _g = 10KΩ; BW = 20Hz to 20KHz		1.5	5	μV
V _{sb}	Stand-By Enable Voltage				1	V

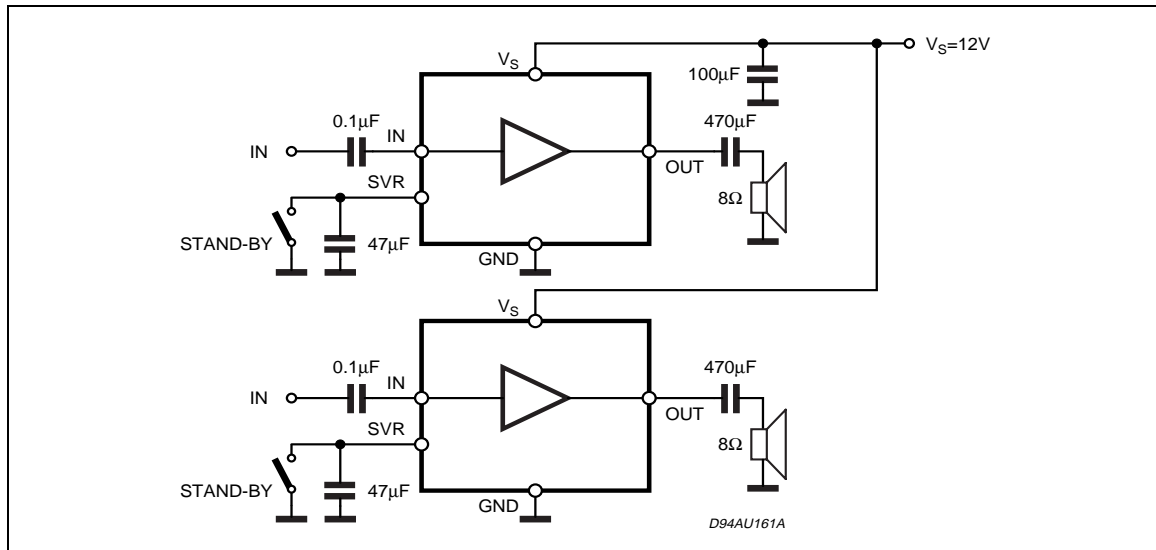
*) Limited by the R_{TH} of the package**Figure 1. Application Circuit****APPLICATION HINTS:**

For 12V supply and 8Ω speaker application, its maximum power dissipation is about 1.8W.

Assuming that max ambient temperature is 70°C. required thermal resistance of the device and heat dissipating means must be equal to $(150 - 70)/1.8 = 45^{\circ}\text{C}/\text{W}$.

Junction to pin thermal resistance of the package is about 20°C/W. That means external heat sink of about 25°C/W is required.

Cu ground plane of PCB can be used as heat dissipating means.

Stand-By switches must be able to discharge C_{SVR} current.

Figure 2. On Board Copper Area

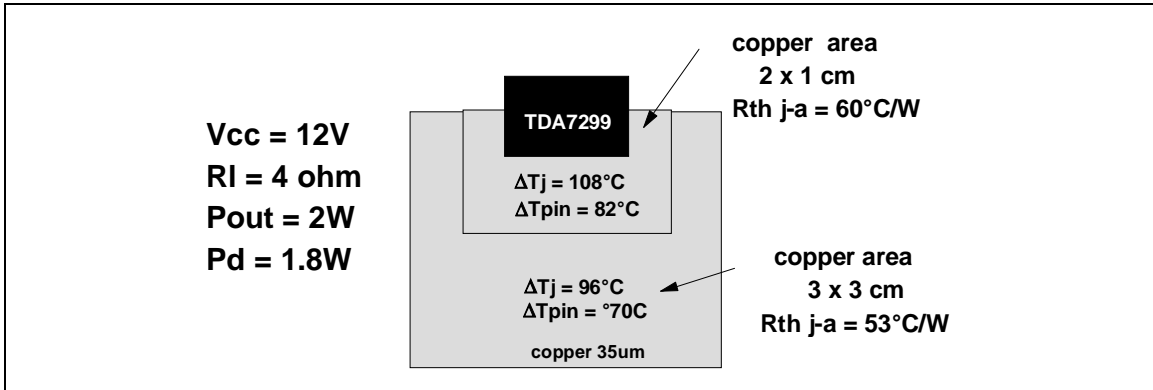

Figure 3. P_{out} vs Supply Voltage (Rload = 8Ω)

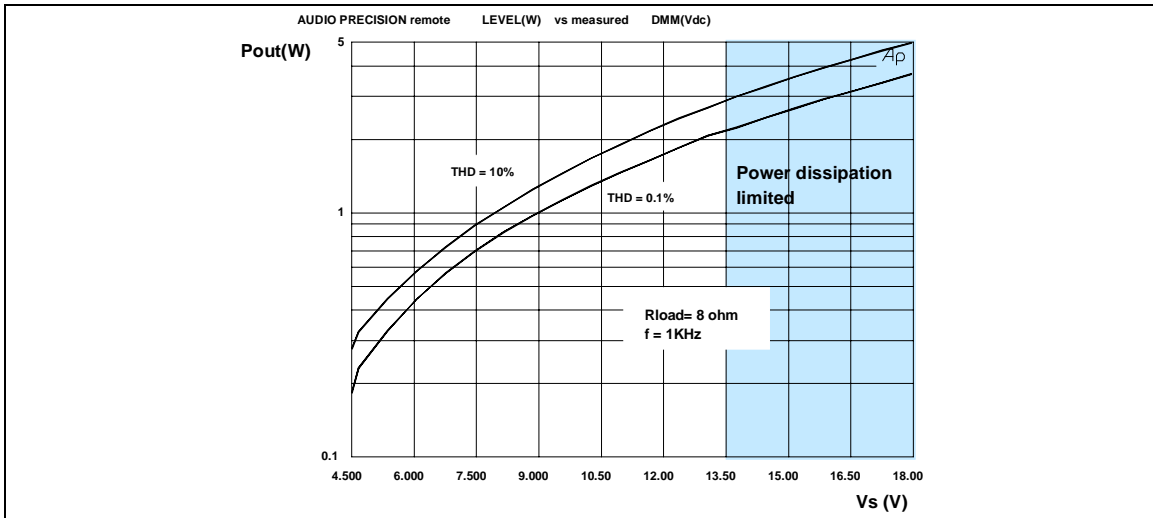

Figure 4. P_{out} vs Supply Voltage (Rload = 4Ω)

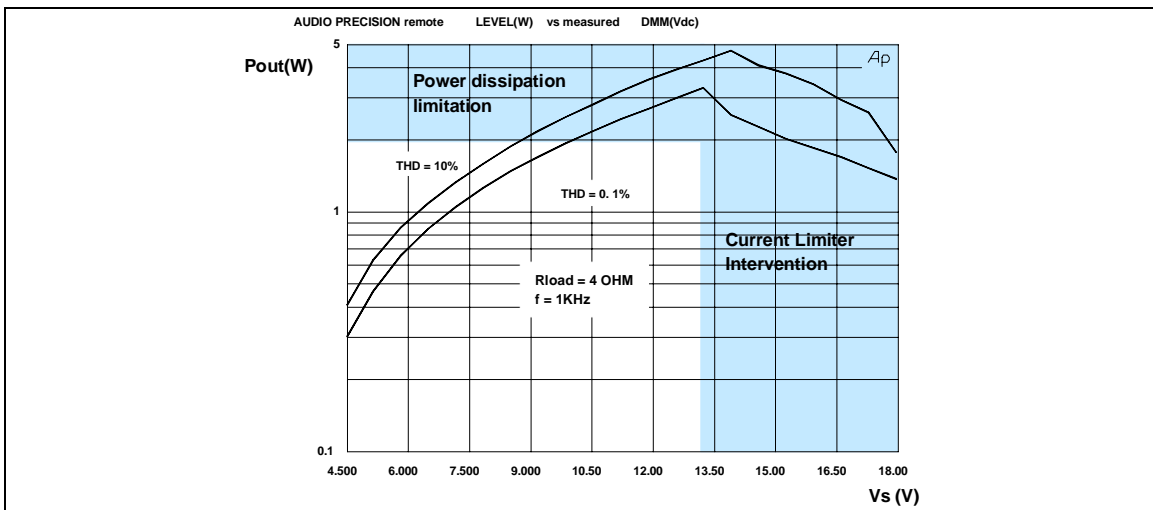
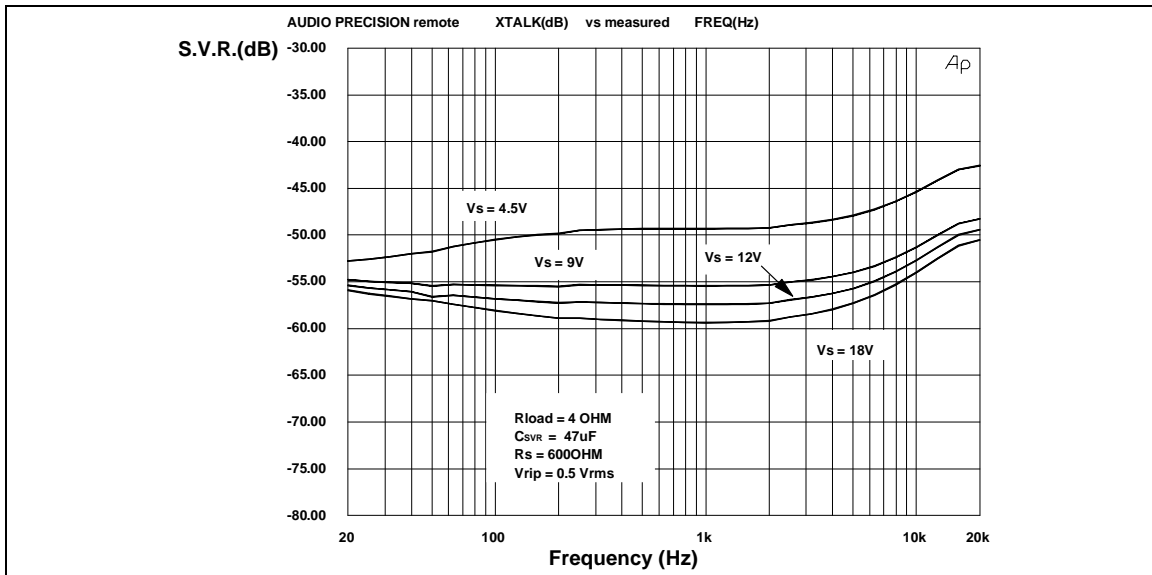
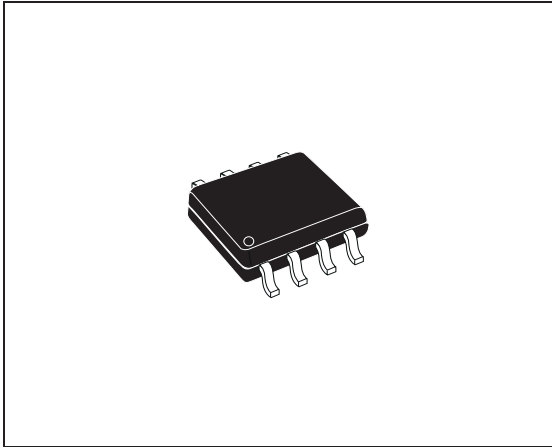

Figure 5. SVR vs Frequency



DIM.	mm			inch		
	MIN.	TYP.	MAX.	MIN.	TYP.	MAX.
A			1.75			0.069
a1	0.1		0.25	0.004		0.010
a2			1.65			0.065
a3	0.65		0.85	0.026		0.033
b	0.35		0.48	0.014		0.019
b1	0.19		0.25	0.007		0.010
C	0.25		0.5	0.010		0.020
c1	45° (typ.)					
D (1)	4.8		5.0	0.189		0.197
E	5.8		6.2	0.228		0.244
e		1.27			0.050	
e3		3.81			0.150	
F (1)	3.8		4.0	0.15		0.157
L	0.4		1.27	0.016		0.050
M			0.6			0.024
S	8° (max.)					

OUTLINE AND MECHANICAL DATA



SO8

(1) D and F do not include mold flash or protrusions. Mold flash or protrusions shall not exceed 0.15mm (.006inch).

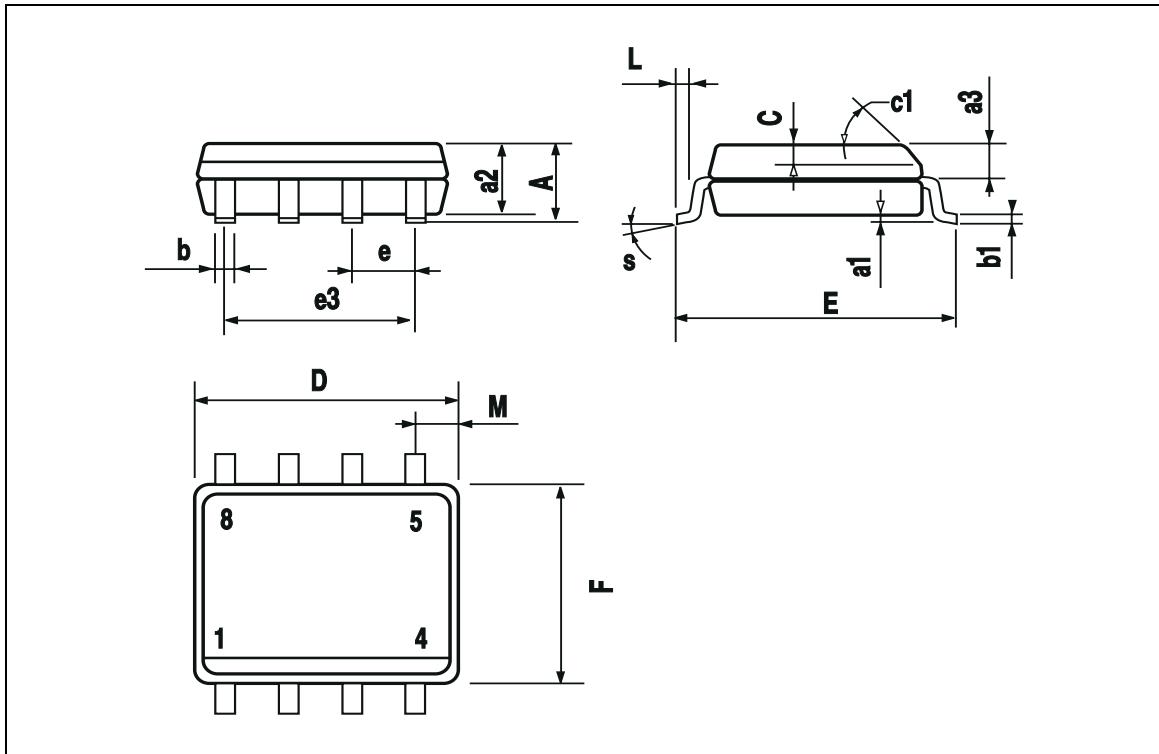

Information furnished is believed to be accurate and reliable. However, STMicroelectronics assumes no responsibility for the consequences of use of such information nor for any infringement of patents or other rights of third parties which may result from its use. No license is granted by implication or otherwise under any patent or patent rights of STMicroelectronics. Specifications mentioned in this publication are subject to change without notice. This publication supersedes and replaces all information previously supplied. STMicroelectronics products are not authorized for use as critical components in life support devices or systems without express written approval of STMicroelectronics.

The ST logo is a registered trademark of STMicroelectronics
© 2002 STMicroelectronics - All Rights Reserved

STMicroelectronics GROUP OF COMPANIES
Australia - Brazil - Canada - China - Finland - France - Germany - Hong Kong - India - Israel - Italy - Japan - Malaysia - Malta - Morocco -
Singapore - Spain - Sweden - Switzerland - United Kingdom - United States.
<http://www.st.com>

