

NS32FX100-15/NS32FX100-20/NS32FV100-20/ NS32FV100-25/NS32FX200-20/NS32FX200-25 System Controller

General Description

The NS32FX200, NS32FV100 and NS32FX100 are highly integrated system chips designed for a FAX system based on National Semiconductor's embedded processors—NS32FX161, NS32FV16 or NS32FX164. The NS32FX100 is the common core for all three system chips. The NS32FV100 and NS32FX200 offer additional functions. Throughout this document, references to the NS32FX100 also apply to both the NS32FV100 and the NS32FX200. Specific NS32FV100 or NS32FX200 features are explicitly indicated.

The NS32FX200, NS32FV100 and NS32FX100 feature an interface to devices like stepper motors, printers and scanners, a Sigma-Delta CODEC, an elapsed-time counter, a DMA controller, an interrupt controller, and a UART.

The NS32FX200 is optimized for high-end FAX applications, such as plain-paper FAX and multifunctional peripherals. The NS32FX100, is optimized for low-cost FAX applications. The NS32FV100 is optimized for thermal paper FAX machines with Digital Answering Machine support.

Features

- Direct interface to the NS32FX161, NS32FV16 and NS32FX164 embedded processors
- Supports a variety of Contact Image Sensor (CIS) and Charge Coupled Device (CCD) scanners
- Direct interface to a variety of Thermal Print Head (TPH) printers. Bitmap shifter and DMA channels facilitate the connection of other types of printers
- Supports two stepper motors
- Direct interface to ROM and SRAM. The NS32FX200 and NS32FV100, in addition, interface to DRAM devices
- Programmable wait state generator
- Demultiplexed address and data buses
- Multiplexed DRAM address bus (NS32FX200 and NS32FV100)
- Supports 3V freeze mode by maintaining only elapsed time counter
- Control of power consumption by disabling inactive modules and reducing the clock frequency
- Operating frequency
 - Normal mode: 19.6608 MHz—24.576 MHz in steps of 1.2288 MHz. (NS32FX200)
 - Normal mode: 19.6608 MHz—24.576 MHz in steps of 1.2288 MHz. (NS32FV100)
 - Normal mode: 14.7456 MHz—19.6608 MHz in steps of 1.2288 MHz. (NS32FX100)
 - Power Save mode: Normal mode frequency divided by sixteen
- On-Chip full duplex Sigma-Delta CODEC with:
 - Total harmonic distortion better than -70 dB
 - Programmable hybrid balance filter
 - Programmable reception and transmission filters
 - Programmable gain control
- On-Chip Interrupt Control Unit with:
 - 16 interrupt sources
 - Programmable triggering mode
- On-Chip counters, WATCHDOG™, UART, MICROWIRE™, System Clock Generator, and I/O ports
- On-Chip DMA controller (NS32FX200—four channels, NS32FX100, NS32FV100—three channels)
- Up to 37 on-chip general purpose I/O pins, expandable externally
- Flexible allocation of I/O and modules' pins
- 132-pin JEDEC PQFP package

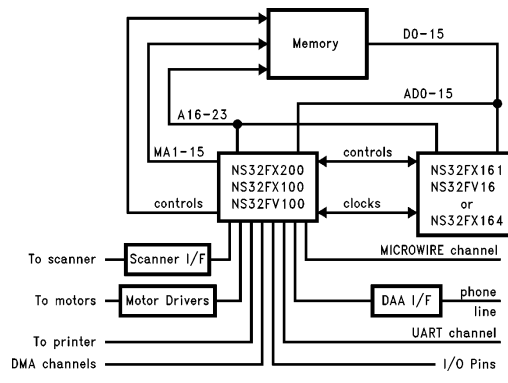

FIGURE 1-1. A FAX Controller Block Diagram

TRI-STATE® is a registered trademark of National Semiconductor Corporation.
MICROWIRE™ and WATCHDOG™ are trademarks of National Semiconductor Corporation.

NS32FX100-15/NS32FX100-20/NS32FV100-20/NS32FV100-25/
NS32FX200-20/NS32FX200-25 System Controller

Table of Contents

1.0 FAX SYSTEM CONFIGURATION	6	2.0 ARCHITECTURE (Continued)	
1.1 Block Diagram Description	6	2.4.3 Registers	23
1.2 Module Diagram	7	2.4.4 Usage Recommendations	24
1.2.1 Bus and Memory Controller (BMC)	8	2.5 Printer Controller (PRNTC)	25
1.2.2 Timing Control Unit (TCU)	8	2.5.1 Features	25
1.2.3 Sigma-Delta CODEC (SDC)	8	2.5.2 Operation	25
1.2.4 Scanner Controller (SCANC)	8	2.5.2.1 Printer Bitmap Shifter Block	25
1.2.5 Printer Controller (PRNTC)	8	2.5.2.2 Thermal Print-Head Control Block	25
1.2.6 DMA Controller (DMAC)	8	2.5.3 Registers	28
1.2.7 Universal Asynchronous Receiver-Transmitter (UART)	8	2.5.4 Usage Recommendations	28
1.2.8 MICROWIRE (MWIRE)	8	2.6 Direct Memory Access Controller (DMAC)	29
1.2.9 Interrupt Control Unit (ICU)	8	2.6.1 Features	29
1.2.10 Ports	8	2.6.2 Description	29
1.3 Operation Modes	8	2.6.2.1 A General DMA Channel	29
1.3.1 Functionality	9	2.6.2.2 Transfer Types	29
2.0 ARCHITECTURE	10	2.6.2.3 Operation Modes	29
2.1 MCFG—Module Configuration Register	10	2.6.3 Detailed Operation Flow	29
2.2 Timing Control Unit (TCU)	10	2.6.4 NS32FX200 DMA Channels	30
2.2.1 Features	10	2.6.5 Registers	30
2.2.2 Operation	10	2.6.6 Usage Recommendations	32
2.2.2.1 External Clocks	11	2.6.7 DMAC Bus Cycles	32
2.2.2.2 Internal Clocks	11	2.7 Universal Asynchronous Receiver-Transmitter (UART)	36
2.2.3 Registers	12	2.7.1 Features	36
2.2.3.1 Usage Recommendations	13	2.7.2 Operation	36
2.3 Sigma-Delta CODEC (SDC)	13	2.7.3 Registers	37
2.3.1 Features	13	2.7.4 Usage Recommendations	38
2.3.2 Operation	13	2.8 MICROWIRE (MWIRE)	38
2.3.2.1 Block Diagram	13	2.8.1 Features	38
2.3.2.2 On-Chip Digital Blocks	15	2.8.2 Operation	38
2.3.3 Programmable Functions	15	2.8.3 Registers	38
2.3.3.1 Sigma-Delta ON/OFF	15	2.8.4 Usage Recommendations	40
2.3.4 Off-Chip Analog Circuits	15	2.9 Interrupt Control Unit (ICU)	40
2.3.4.1 Analog Transmitter	17	2.9.1 Features	40
2.3.4.2 Analog Receiver	17	2.9.2 Operation	40
2.3.5 Registers	17	2.9.3 Registers	41
2.3.6 Usage Recommendations	18	2.9.4 Usage Recommendations	41
2.4 Scanner Controller (SCANC)	18	2.10 Ports Module	41
2.4.1 Features	18	2.10.1 Features	41
2.4.2 Operation	18	2.10.2 Operation	41
2.4.2.1 Scanner Signals Generator Block	19	2.10.2.1 General Purpose Input/Output Ports	41
2.4.2.2 Scanner Period Pulse (SPP) Generation	20	2.10.2.2 External Output Port Extension	43
2.4.2.3 Video Handling Block	21	2.10.2.3 Stepper Motors Output Ports	43
2.4.2.4 Threshold DAC (Dithering and Automatic Background Control)	22	2.10.3 Registers	43
2.4.2.5 Stepper Motor Control Block	23	2.10.4 Usage Recommendations	45

Table of Contents (Continued)

2.0 ARCHITECTURE (Continued)		3.0 SYSTEM INTERFACE (Continued)	
2.11 Bus and Memory Controller (BMC)	45	3.3 Control of Power Consumption	53
2.11.1 Features	45	3.4 Bus Cycles	54
2.11.2 Operation	45	4.0 DEVICE SPECIFICATIONS	62
2.11.2.1 Zones 0, 1 (ROM and SRAM) Transactions	46	4.1 NS32FX100 Pin Descriptions	62
2.11.2.2 Zone 2 (Dynamic Memory) Transactions (NS32FX200 and NS32FV100 only)	46	4.1.1 Supplies	62
2.11.2.3 Zone 3 (I/O) Transactions	47	4.1.2 Input Signals	62
2.11.2.4 Operation in Freeze Mode	47	4.1.3 Output Signals	63
2.11.2.5 On-Chip Registers Access	47	4.1.4 Input/Output Signals	64
2.11.3 Registers	47	4.2 Output Signal Levels	64
2.11.4 Usage Recommendations	48	4.2.1 Freeze Mode Output Signals	65
2.12 Register Summary	48	4.2.2 Reset/Power Restore Output Signals	65
2.12.1 NS32FX100 Registers Access Method	48	4.3 Absolute Maximum Ratings	67
2.12.2 NS32FX200, NS32FV100 and NS32FX100 Registers	48	4.4 Electrical Characteristics	67
3.0 SYSTEM INTERFACE	53	4.5 Analog Electrical Characteristics	69
3.1 Power and Grounding	53	4.6 Switching Characteristics	70
3.2 Clocks and Traps Connectivity	53	4.6.1 Definitions	70
		4.6.2 Timing Tables	71
		4.6.2.1 Output Signals: Internal Propagation Delays	71
		4.6.2.2 Input Signal Requirements	76
		APPENDIX A: CODEC TRANSMISSION PERFORMANCE	92

List of Figures

FIGURE 1-1	A FAX Controller Block Diagram	1
FIGURE 1-2	NS32FX100 Module Diagram	7
FIGURE 1-3	NS32FV100 Module Diagram	7
FIGURE 1-4	NS32FX200 Module Diagram	7
FIGURE 1-5	System Chip States and Operation Modes	9
FIGURE 2-1	Clocks and Traps Connectivity	10
FIGURE 2-2	High Speed Oscillator Clocks	11
FIGURE 2-3	Low Speed Oscillator Clocks	11
FIGURE 2-4	Sigma-Delta Block Diagram	14
FIGURE 2-5	SDC Off-Chip Analog Circuit	16
FIGURE 2-6	Block Diagram of Scanner's Signals Generator Block	19
FIGURE 2-7	Scanner Pixel Control Signals	20
FIGURE 2-8	Scanner Period Control Signals	21
FIGURE 2-9	Block Diagram of Scanner's Video Handling Block	21
FIGURE 2-10	Dither Cyclic Buffer	22
FIGURE 2-11	Bitmap Shifter Signals	25
FIGURE 2-12	Four Strobes Mode (STBM = 00)	26
FIGURE 2-13	Two Strobes Mode (STBM = 01)	26
FIGURE 2-14	Temperature ADC	27
FIGURE 2-15	DMA Fly-By Read Transaction (DIR=0, FBY= 0)	32
FIGURE 2-16	DMA Fly-By Write Transaction (DIR= 1, FBY=0)	33
FIGURE 2-17	DMA Memory to I/O Read Transaction (DIR=0, NFBY= 1)	34
FIGURE 2-18	DMA I/O to Memory Write Transaction (DIR= 1, NFBY= 1)	35
FIGURE 2-19	Two Adjacent Fly-By DMA Transactions	36
FIGURE 2-20	Character Format	37
FIGURE 2-21	MICROWIRE Transaction (CLKM=0)	39
FIGURE 2-22	MICROWIRE Transaction (CLKM= 1)	39
FIGURE 2-23	Port A	42
FIGURE 2-24	Port B	42
FIGURE 2-25	Port C	42
FIGURE 2-26	External Output Port Extension	43
FIGURE 3-1	Power and Ground Connections	53
FIGURE 3-2	Oscillator Circuits	53
FIGURE 3-3	Zones 0, 1 (ROM/SRAM) Read Transaction, Zero Wait State	54
FIGURE 3-4	Zones 0, 1 (ROM/SRAM) Read Transaction, One Wait State	54
FIGURE 3-5	Zones 0, 1 (ROM/SRAM) Write Transaction, Zero Wait State	55
FIGURE 3-6	Zones 0, 1 (ROM/SRAM) Write Transaction, One Wait State	55
FIGURE 3-7	Zone 2 (DRAM) Refresh Transaction, Zero Wait State	56
FIGURE 3-8	Zone 2 (DRAM) Refresh Transaction, Three Wait States	56
FIGURE 3-9	Freeze Mode Refresh Transaction Waveform	56
FIGURE 3-10	Zone 2 (DRAM) Read Transaction, Zero Wait State	57
FIGURE 3-11	Zones 0, 1 Access Delayed by a Refresh Transaction (No Wait)	57
FIGURE 3-12	Zone 2 (DRAM) Read Transaction, One Wait State	58
FIGURE 3-13	Zone 2 (DRAM) Write Transaction, Zero Wait State	58
FIGURE 3-14	Zone 2 (DRAM) Write Transaction, One Wait State	59
FIGURE 3-15	Zone 3 (I/O) Read Transaction, Two Wait States	59
FIGURE 3-16	Zone 3 (I/O) Read Transaction, Four Wait States	60
FIGURE 3-17	Zone 3 (I/O) Write Transaction, Four Wait States	60
FIGURE 3-18	Zone 3 (I/O) Write Transaction, Six Wait States	61
FIGURE 3-19	CPU/DMA Arbitration	61
FIGURE 3-20	Spaced Memory Transaction, Two Tidles after T4	61

List of Figures (Continued)

FIGURE 4-1	Connection Diagram—Top View	.66
FIGURE 4-2	Analog Circuitry Block Diagram	.69
FIGURE 4-3	TTL—Output Signals Specification Standard	.70
FIGURE 4-4	TTL—Input Signals Specification Standard	.70
FIGURE 4-5	CMOS—Output Signals Specification Standard	.70
FIGURE 4-6	CMOS—Input Signals Specification Standard	.70
FIGURE 4-7	Input Hysteresis	.70
FIGURE 4-8	Clock Waveforms	.79
FIGURE 4-9	DRAM Read Bus Cycle	.79
FIGURE 4-10	DRAM Write Bus Cycle	.80
FIGURE 4-11	ROM/SRAM Read Bus Cycle	.81
FIGURE 4-12	ROM/SRAM Write Bus Cycle (One Wait State)	.82
FIGURE 4-13	I/O Read Bus Cycle	.83
FIGURE 4-14	I/O Write Bus Cycle	.83
FIGURE 4-15	DRAM Refresh Bus Cycles	.84
FIGURE 4-16	DMA Read Transaction (DIR = 0)	.85
FIGURE 4-17	DMA Write Transaction (DIR = 1)	.86
FIGURE 4-18	Interrupt Signals Timing	.87
FIGURE 4-19	Sigma-Delta Signals Timing	.87
FIGURE 4-20	SBYPS Input Signal Timing	.87
FIGURE 4-21	Printer Signals Timing	.88
FIGURE 4-22	Reset Signals Timing	.88
FIGURE 4-23	Scanner Signals Timing	.89
FIGURE 4-24	UART Signals Timing	.90
FIGURE 4-25	MWIRE Signals Timing	.90
FIGURE 4-26	Ports Signals Timing	.91
FIGURE 4-27	Analog Signals Timing	.91

List of Tables

TABLE 2-1	CTTL, MCLON and MCLOFF Values	.12
TABLE 2-2	Component Values	.15
TABLE 2-3	Interrupt Sources and Priority Levels	.40
TABLE 2-4	DRAM Address Multiplexing	.46
TABLE 2-5	DRAM Address Sizes	.46
TABLE 3-1	R, C and L Values	.53
TABLE 3-2	System Chip Operation Modes and Power Consumption	.53
TABLE A-1	Transmitter Performance	.92
TABLE A-2	Receiver Performance	.93

1.0 Fax-System Configuration

A typical FAX system based on the NS32FX100, NS32FX200 or NS32FV100, is shown in *Figure 1-1*.

1.1 BLOCK DIAGRAM DESCRIPTION

CPU. The typical FAX system shown below is based on a single embedded processor. The choice between the NS32FX161, NS32FV16 and the NS32FX164 depends on the specific application requirements.

System Chip. The FAX-system chip interfaces between FAX-system peripheral devices, such as motors, printers and scanners, and the embedded processor. The chip contains FAX-system elements such as CODEC, DMA Controller, Interrupt Control Unit and counters.

Scanner. Either a Charge-Coupled Device (CCD) scanner or a Contact Image Sensor (CIS) scanner may be used. The NS32FX100 incorporates most of the video circuits, such as shading compensation, dithering and digitizing, which are required for the scanner interface.

Printer. A Thermal Print Head (TPH) can be connected directly to the NS32FX100. Other types of printer engine, such as laser or ink-jet, can easily be interfaced to the NS32FX100 via an additional, small ASIC.

Motors. The NS32FX100 controls two stepper motors. The only external components required to operate the motors are buffers/drivers.

DAA I/F. The telephone line is accessed via a Data Access Arrangement (DAA). The NS32FX100 contains the digital part of a Sigma-Delta CODEC, which connects to the DAA.

A few external components are required to implement the analog part of the CODEC.

Memory. The NS32FX100 directly controls ROM and SRAM. Both the NS32FX200 and the NS32FV100 directly control DRAM, in addition to ROM and SRAM.

Memory access time is also controlled by the NS32FX100, thus allowing the designer to tune memory price and system performance.

MICROWIRE. The serial channel, with programmable interface parameters, can be used by advanced FAX systems to interface with other devices (such as EEPROMs).

UART. This serial channel, with programmable interface parameters, can be used by advanced fax systems to communicate with other devices (e.g., host machines).

I/O Pins. General purpose I/O pins are used both to monitor (e.g., ring detector read) and control (e.g. scanner light control) the FAX-system peripheral devices.

DMA Channels:

NS32FX100 and NS32FV100. The NS32FX100 and NS32FV100 have three DMA channels which are used to interface the scanner and the printer. All three channels may be allocated for external usage (e.g., Centronics parallel interface, Ethernet).

NS32FX200. The NS32FX200 has four DMA channels. Three channels are used by the NS32FX200 to interface to the scanner and the printer, and one channel is for external usage. All four channels may be allocated for external usage (e.g., Centronics parallel interface, Ethernet).

1.0 Fax-System Configuration (Continued)

1.2 MODULE DIAGRAM

The various functions of the NS32FX100, NS32FV100 and NS32FX200 are performed by on-chip modules as shown below.

The NS32FX100 module diagram is shown in *Figure 1-2*.

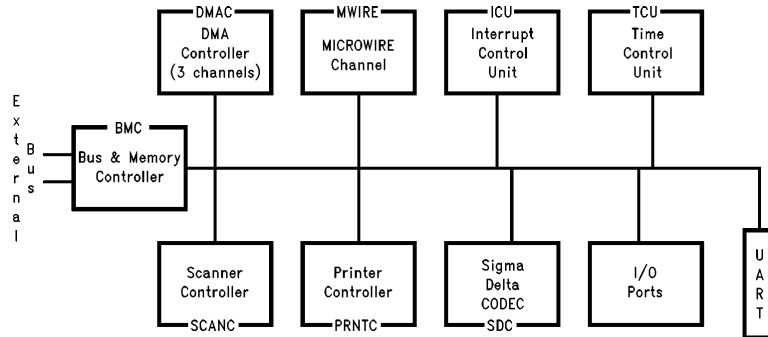

FIGURE 1-2. NS32FX100 Module Diagram

TL/EE/11331-3

The NS32FV100 module diagram is shown in *Figure 1-3*.

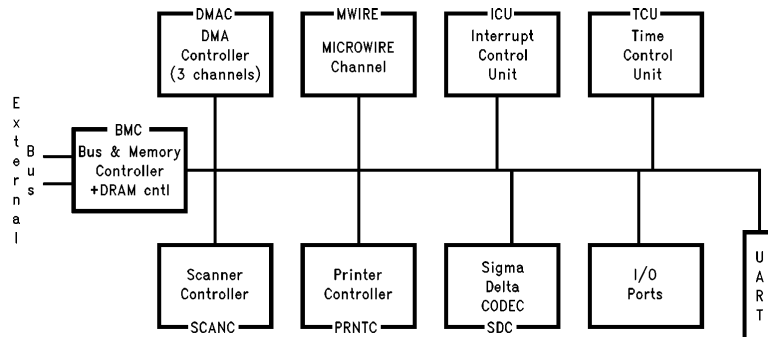

FIGURE 1-3. NS32FV100 Module Diagram

TL/EE/11331-4

The NS32FX200 module diagram is shown in *Figure 1-4*.

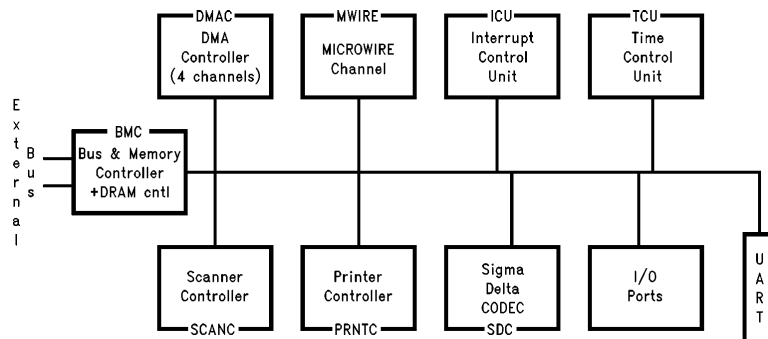

FIGURE 1-4. NS32FX200 Module Diagram

TL/EE/11331-2

1.0 Fax-System Configuration (Continued)

The NS32FX100 modules, and their functions, are summarized below. For a more detailed description of each module, see the relevant section.

1.2.1 Bus and Memory Controller (BMC)

The Bus and Memory Controller (BMC) interfaces directly to the NS32FX161, the NS32FV16 or the NS32FX164. It enables the NS32FX100 to respond to both read and write transactions, and to generate DMA transactions. It divides the address space into four external zones and generates wait states, and idle cycles, according to the addressed zone, type of transaction and the programmed wait value. The memory controller directly interfaces to ROMs and SRAMs. The memory controllers of the NS32FX200 and the NS32FV100, in addition, directly interface to DRAMs.

1.2.2 Timing Control Unit (TCU)

The Timing Control Unit (TCU) contains three blocks. An oscillators block generates the CPU high-speed clock and the time-keeper clock. The TCU module keeps trace of elapsed time during all operation modes. A counters block contains timers/counters for the various FAX-system controller operations.

1.2.3 Sigma-Delta CODEC (SDC)

The Sigma-Delta CODEC (SDC) interfaces with the telephone line via an external Data Access Arrangement (DAA), performing analog-to-digital and digital-to-analog conversions, data sampling and buffering. Off-hook control and ring-detect monitoring are performed by the Ports module.

1.2.4 Scanner Controller (SCANC)

The Scanner Controller (SCANC) contains the video handling block, the scanner signals generator and the stepper motor control block. The block includes both analog and digital circuits. It uses DMA channel 0 to fetch a reference line from memory and DMA channel 2 to store the digitized video data to memory.

1.2.5 Printer Controller (PRNTC)

The Printer Controller (PRNTC) contains the printer bitmap shifter, the stepper motor control block, the temperature-sensing block and the thermal print head control block. It uses DMA channel 1 to fetch the bitmap from memory.

1.2.6 DMA Controller (DMAC)

NS32FX200. The DMA Controller (DMAC) provides four independent channels for transferring blocks of data between memory and I/O devices, with minimal CPU intervention. Two channels are used for scanner control, one for printer control and one is available for external usage.

NS32FX100, NS32FV100. The DMA Controller (DMAC) provides three independent channels for transferring blocks of data between memory and I/O devices, with minimal CPU intervention. Two channels are used for scanner control, one for printer control.

1.2.7 Universal Asynchronous Receiver-Transmitter (UART)

The Universal Asynchronous Receiver-Transmitter (UART) supports 7-bit or 8-bit data formats, with or without parity, with or without hardware flow control, and with one or two stop bits. The baud rate is generated on-chip, under software control.

1.2.8 MICROWIRE (MWIRE)

The MWIRE is a serial synchronous communication interface. It enables the CPU to interface with any of National Semiconductor's chips which support MWIRE, such as COP400, COP800 and EEPROMs. The MWIRE interface consists of three signals—serial data in, serial data out, and shift clock. Several devices can share the MWIRE channel using selection signals provided by the Ports module.

1.2.9 Interrupt Control Unit (ICU)

The Interrupt Control Unit (ICU) receives internal and external interrupt sources and generates an interrupt to the CPU when required. Priority is allocated according to a predetermined scheme. The ICU supports programmable triggering mode and polarity. Each interrupt source can be individually enabled or disabled. Pending interrupts can be polled, regardless of whether they are enabled or disabled.

1.2.10 Ports

The Ports module controls the usage of general-purpose input and output pins. The pins are shared with other modules, and can be configured either as general-purpose I/O pins or as pins that belong to other modules. An input port always holds the current value/state of its associated pins. Output pins can be enabled or disabled (TRI-STATE®).

The number of general-purpose output pins can easily be increased using an external latch (e.g., DM74LS373).

1.3 OPERATION MODES

The NS32FX100 operates in one of three modes:

- **Normal Mode:** The CPU operates at the full clock frequency. Maximum current consumption is 200 mA.
- **Power Save Mode:** The CPU runs at 1/16 of the Normal mode frequency. DMA channels must be disabled, output ports must be TRI-STATE, and MCFG, except for bit 0, must be cleared. Maximum current consumption is 17 mA.
- **Freeze Mode:** The CPU is frozen by active reset and frozen clock; it is not connected to the backup battery. The NS32FX100 chip keeps track of elapsed time. The NS32FX200 and NS32FV100 can, if required, refresh the memories. Maximum current consumption is 1 mA with refresh, and 0.1 mA without refresh.

In normal operation, (see *Figure 1-5*) when reset is asserted, the NS32FX100 enters S6 of the Power Save mode. Switching from Power Save to Normal mode is carried out by software.

An RC circuit may be used to generate the CPU's input reset signal. The WATCHDOG trap signal (WDT), generated by the NS32FX100, may also force active CPU's input reset. The NS32FX100 receives its reset from the CPU output reset signal. This line should be pulled down by a resistor to force reset in case the CPU is not powered.

Failure of the main power source is detected externally (see *Figure 1-6*). The CPU is notified by a non-maskable interrupt. The NS32FX100 is also notified that power has failed, through the PFAIL input pin. The NS32FX100 power source should be externally switched to the backup battery. The

1.0 Fax-System Configuration (Continued)

power-fail input is asynchronous. It is recognized by the NS32FX100 during cycles in which the input setup-time requirement is satisfied.

Switching from Normal mode to Power Save mode, and vice versa, must always be carried out using the NS32FX100 explicitly. The clock scaling option of the CPU should not be used for this purpose.

1.3.1 Functionality

State S1: Normal Mode. The system operates at the full clock frequency. The NS32FX100 is powered by the main power supply. Software can switch the system to state S7, Power Save Mode.

The NS32FX100 switches to state S2, Power Fail, when $\overline{\text{PFAIL}}$ is asserted.

State S2: Power Fail. In this state, the CPU enters an NMI handler, in which the software performs all the bookkeeping required for recovery and switches to full clock frequency. The software should write H'80 to MCFG. Once finished, the software activates the WATCHDOG trap output signal, which asserts the $\overline{\text{RST}}$ input of the CPU by writing three times to the WATCHDOG.

When both $\overline{\text{PFAIL}}$ and $\overline{\text{RST}}$ are active, the NS32FX100 and the RAM must be powered from a battery. The CPU can be powered down.

When $\overline{\text{RST}}$ is detected, the system chip goes from S2 to one of the following states:

State S3, if DRAM refresh is enabled (only in NS32FV100 and NS32FX200).

State S5, if no DRAM refresh is needed (NS32FX100—always).

State S3: Complete Refresh Transaction. If $\overline{\text{RST}}$ is detected, while refresh is enabled, in state S2, a refresh transaction is performed. The system chip then switches to state S4.

State S4: Freeze and Refresh. In this state, the system chip de-activates the fast crystal oscillator and freezes the CCLK clock. Only the Elapsed Time Counter and the DRAM refresh generator are functional.

When the ETC count reaches zero, the state machine switches to state S5, and refresh transactions are stopped. Thus, the contents of the DRAM can be kept for a predefined period (software programmable). If the power failure lasts longer than this period, the system should disconnect the DRAM and leave only the ETC, and possibly an SRAM device, connected to the battery.

If $\overline{\text{PFAIL}}$ goes high, the state machine switches to state S6, Power Restore.

State S5: Freeze—No Refresh. In this state only the ETC counter is active—counting the duration of the power failure. In this state the NS32FX100 functions with a supply voltage as low as 3V.

If $\overline{\text{PFAIL}}$ goes high, the state machine switches to state S6, Power Restore.

State S6: Power Restore. This state can be entered either from Freeze Mode or during normal operation when reset is asserted. When entering from Freeze Mode ($\overline{\text{PFAIL}}$ goes high), $\overline{\text{RST}}$ is kept low for a few milliseconds by an external circuit. During this time, the fast crystal oscillator is activated and the CPU and NS32FX100 clocks are synchronized.

If refresh is enabled, the system chip will initiate refresh transactions during this time—the refresh rate is forced to a default value.

When $\overline{\text{RST}}$ goes high, the NS32FX100 switches to state S7, Power Save Mode.

State S7: Power Save Mode. The CPU runs at a slow frequency—1/16 of the Normal Mode frequency.

The system can switch to S1, Normal Mode, under software control.

If $\overline{\text{PFAIL}}$ input is asserted, the NS32FX100 switches to state S2, Power Fail.

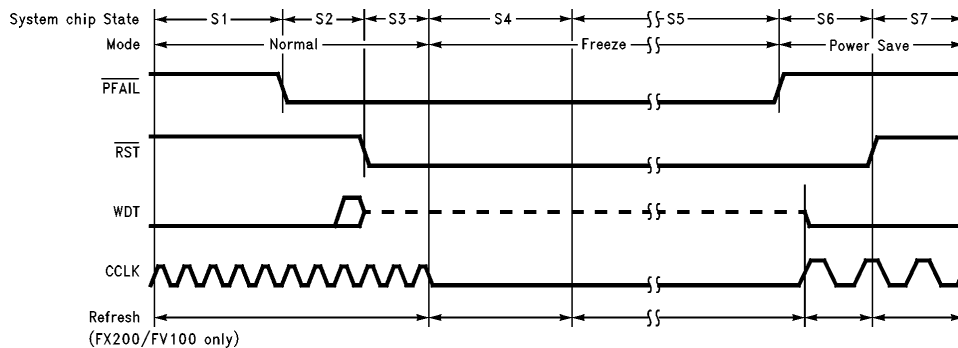

FIGURE 1-5. System Chip States and Operation Modes

TL/EE/11331-5

2.0 Architecture

2.1 MCFG—MODULE CONFIGURATION REGISTER

The software can configure some of the NS32FX100 major operation modes by programming the Module Configuration Register (MCFG). Some of the bits in this register are also used to initialize the TPH block in the PRNTC, the bitmap shifter block in the PRNTC and the scanner module. When a bit in the MCFG is “0”, the associated module is idle. Setting a bit to “1” enables the operation of the associated module. Prior to activating a module, its appropriate registers must be initialized by software.

15	6	5	4	3	2	1	0
res	ESDC	EDMA0	ESCAN	EPBMS	ETPHB	ECOUNT	

- ECOUNT:** Enable internal counters of the TCU module. Once set, this bit can not be cleared by software. The TCU counters, except TIMER and WDC, must be initialized prior to setting this bit since they start working when the ECOUNT bit is set.
- ETPHB:** Enable Thermal Print-Head Block of the PRNTC module. The strobe-on and strobe-off counters of this block must be initialized prior to setting this bit to “1”.
- EPBMS:** Enable Bitmap Shifter Block of the PRNTC module. Clearing this bit is treated, by the Bitmap Shifter, as a hardware reset. The block starts operating when this bit is set. When disabled, DMA channel 1 uses the printer PCLK/DMRQ1 pin.

- ESCAN:** Enable Scanner module. Clearing this bit is treated, by the Scanner Controller, as a hardware reset. The module starts operating when this bit is set. When cleared to “0”, DMA channel 2 uses the scanner pins and interrupt.
- EDMA0:** Enable scanner usage of DMA channel 0. When cleared to “0”, DMA channel 0 uses the scanner pins and interrupt.
- ESDC:** Enable Sigma-Delta CODEC module. When this bit is set the SDC operation takes place as described in Section 2.3.

Upon reset the non reserved bits of the MCFG are cleared to “0”, thus disabling the above modules and options.

2.2 TIMING CONTROL UNIT (TCU)

2.2.1 Features

- Generation and control of clock running frequency
- CPU and NS32FX100 synchronization by Phase Lock Loop (PLL)
- Fixed System-Tick interrupt of 100 Hz
- WATCHDOG
- Timer
- Buzzer
- Freeze mode

2.2.2 Operation

The Timing Control Unit (TCU) is responsible for generating the clocks, used for the various timing and counting functions in the system, and for freeze mode operation. *Figure 2-7* shows how the clocks are connected in an NS32FX100-based FAX system.

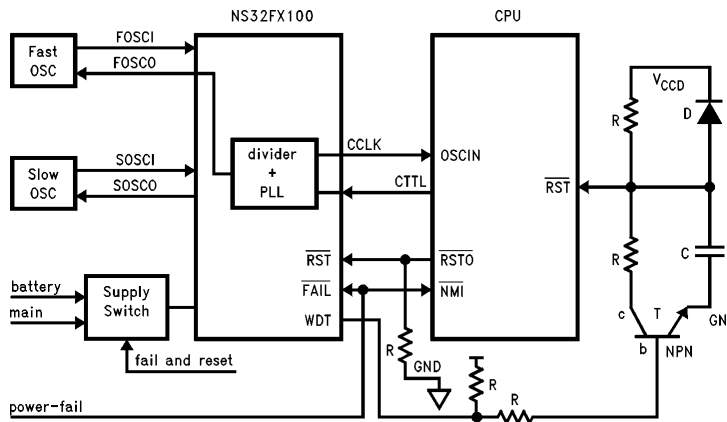

FIGURE 2-1. Clocks and Traps Connectivity

TL/EE/11331-6

2.0 Architecture (Continued)

2.2.2.1 External Clocks

The TCU contains two oscillators, the high-speed oscillator and the low-speed oscillator. The high-speed oscillator is the FAX system clocking source. It generates the CPU clock and, after division, clocks for the Sigma-Delta CODEC, scanner, printer and serial communications channels. A high-speed clock signal is input to the NS32FX100, from an external crystal, through the FOSCI pin. The NS32FX100 uses this signal to generate the CCLK clock, which serves as the input clock to the CPU. The CPU then divides CCLK by two, and generates CTTL which serves as the bus clock. The NS32FX100 includes a PLL to ensure synchronization between the NS32FX100 clocks and the CPU. CTTL is used to close the PLL loop and enable tracking of the CPU internal clocks.

The low-speed oscillator, which gets its input through the SOSCI pin, is used to keep track of elapsed time and to operate the refresh requester. This oscillator operates in Normal mode, as well as in Power Save and Freeze modes.

The NS32FX100 controls the CPU running frequency. It may reduce the frequency by dividing CCLK by 16. To ensure accurate tracking of the CTTL phase by the NS32FX100, clock division should be carried out via the NS32FX100, and the power save mode of the CPU should not be used.

The slow oscillator, which operates during Normal, Power Save and Freeze modes, can be a 32.768 kHz oscillator for systems with memory refresh rate of up to 8 kHz. Systems with memory refresh rate higher than 8 kHz should use a slow oscillator of 455 kHz.

2.2.2.2 Internal Clocks

The TCU module generates a 1.2288 MHz Master Clock (MCLK). MCLK is generated by a programmable divider, which divides the CTTL input clock. The MCLK clock is used for synchronization throughout the NSFX100-based FAX system. In particular, the following are derived from MCLK:

- CLK128—A 12.8 kHz clock
- Time-Slots generator (TSL)—An 8-bit down counter fed by CLK128

The Time-Slots generator performs two functions:

- Division of each 20 ms period into 256 time slots
- Generation of a 100 Hz System Tick (STIC)

The time slots are used to synchronize the various components of the FAX system, e.g., the printer and scanner with their respective motors.

The System Tick is used by both the Interrupt Control Unit (ICU), for generating an interrupt, and by the WATCHDOG counter, as described in Section 2.2.3.

Several registers are provided, to control and use the TCU and I/O signals. These registers are described in Section 2.2.3.

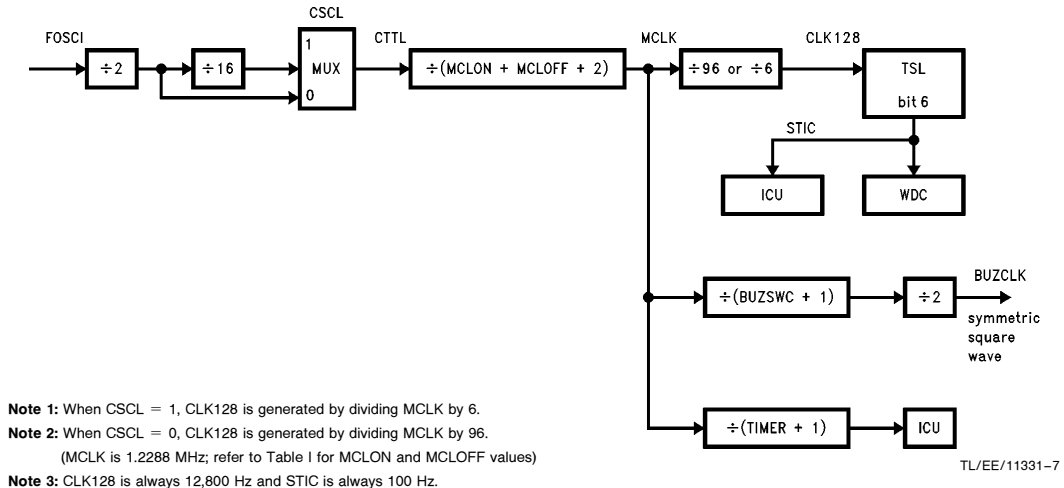

FIGURE 2-2. High Speed Oscillator Clocks

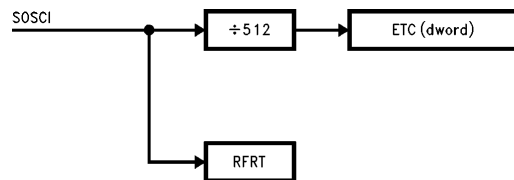

FIGURE 2-3. Low Speed Oscillator Clocks

TL/EE/11331-8

2.0 Architecture (Continued)

2.2.3 Registers

CSSL: CCLK (CPU Input Clock) Scale register.

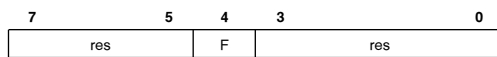

F: Controls the CCLK frequency.

1: The CCLK frequency is the FOSCI input frequency divided by 16.

0: The CCLK frequency is the FOSCI input frequency.

Upon reset F is set to "1".

res: Reserved

MCLOFF: MCLK Off Time. 8-bit register.

MCLOFF should be set to a fixed value, as shown in Table I, as a function of CTTL in normal operation mode, to generate a 1.2288 MHz clock, thus controlling the CTTL duty cycle.

MCLON: MCLK On Time. 8-bit register.

MCLON should be set to a fixed value, as shown in Table I, as a function of CTTL in normal operation mode, to generate a 1.2288 MHz clock, thus controlling the CTTL duty cycle.

TABLE 2-1. CTTL, MCLON and MCLOFF Values

CTTL (MHz)	MCLON	MCLOFF
14.7456	5	5
15.9744	6	5
17.2032	6	6
18.4320	7	6
19.6608	7	7
20.8896	8	7
22.1184	8	8
23.3472	9	8
24.5760	9	9

TIMER: Programmable Timer.



TIMER: The actual counter bits.

TIMER is a programmable, retriggerable, down counter which generates an interrupt pulse after a programmable number of MCLK cycles. When it goes below zero it stops counting and holds the value 0x0fff. If a new value is written to the TIMER before it reaches zero, it starts counting down from this new value. Reading TIMER gives its current contents.

Each bit in the TIMER register stands for 0.8 μ s (1/1.2288 MHz), thus the counter may represent the maximum value of 0.8 x 2¹⁶ μ s.

Writing "0" to the timer is not allowed.

BUZCFG: Buzzer Configuration register.

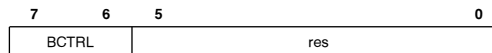

BCTRL: Used to control the BUZCLK pin.

00: BUZCLK pin = 0.

01: BUZCLK pin = 1.

10: BUZCLK pin = symmetric square wave, according to BUZSWC register.

11: Reserved.

BUZSWC: Buzzer Square Wave Counter. 16-bit register.

Used for dividing MCLK to generate a symmetric square wave on the BUZCLK pin, as follows:

BUZCLK frequency = MCLK / (2 * BUZSWC + 2).

WDC: WATCHDOG Counter. 8-bit register.

The WATCHDOG Counter (WDC) is a down counter that counts STIC pulses. The counter generates a trap signal, on the WATCHDOG Trap (WDT) pin, if the counter reaches zero, or if WDC is written into more than once per STIC cycle. After reset WDC is idle (not counting). It starts counting after it is first written, starting from the value that is written into it. Once started, WDC can be stopped only by a hardware reset.

The WATCHDOG counts STIC pulses which are generated by the TCU. Therefore the WATCHDOG is functional only when the TCU's counters are enabled by the MCFG.ECOUNT bit.

Writing "0" to the timer is not allowed.

TSL: Time Slot down counter. 8-bit, read only.

Holds the current time slot. Upon reset the TSL bits are set to "1".

ETC: Elapsed Time Counter. A 32-bit down counter that counts at a rate of the slow clock (SOSCI) divided by 512.

Accessed as double-word only.

Not affected by reset.

At least four slow-clock cycles are required, between a write and any accesses to ETC, to avoid unpredictable results.

Successive reads from the ETC may differ from each other by two.

Example:

Read ETC, value = n (correct value should be n + 1)

Read ETC, value = n + 2 (correct value).

RFRT: Refresh Rate Control. 8-bit register.

The refresh is set to occur once every (RFRT + 1) cycles of the slow clock. RFRT must be set to a minimum value of 3.

The actual refresh transaction may be postponed due to synchronization with the fast clock and with other memory transactions.

2.0 Architecture (Continued)

After reset, RFRT is initialized to 6.

Writing to RFRT must be followed by read back to ensure that the RFRT has, in fact, been updated. This procedure must be repeated until RFRT is updated (value read = value written).

RFRT exists only in the NS32FV100 and the NS32FX200.

RFEN: Refresh enable

7	6	5	0
res	EN	res	

EN 0: No refresh transactions.

1: Refresh transactions are issued by the chip according to the refresh rate, selected by RFRT.

After reset EN is set to "1".

RFEN exists only in the NS32FV100 and the NS32FX200.

2.2.3.1 Usage Recommendations

The ECOUNT bit, in MCFG, must be set to enable TCU counters operation.

2.3 SIGMA-DELTA CODEC (SDC)

2.3.1 Features

- 16-bit format Analog-to-Digital converter and Digital-to-Analog converter
- Full and Half Duplex operation
- Optimized for FAX and DATA Modems
- Various sampling rates for voice and data applications
- Total harmonic distortion better than -70 dB

- Programmable IIR filters
 - Programmable transmit filters
 - Programmable receive filters
 - Programmable echo canceling filter
- Programmable gain control
- Programmable fine timing tuning
- Digital loop-back mode
- Reduced CPU load by 12-level transmission FIFO and 12-level reception FIFO

2.3.2 Operation

The Sigma Delta CODEC performs high resolution analog-to-digital (A/D) and digital-to-analog (D/A) conversions using an over sampling technique. This module is optimized for use as the analog front end for Digital Signal Processing (DSP) applications such as modems or voice processing.

The SDC's main advantage, compared to other A/D and D/A converters, is the use of digital circuitry resulting in high reliability and reduced cost. The SDC solution incorporates a second-order, digital Sigma-Delta modulator and a noise shaping technique to improve performance.

The digital parts of the converters are implemented on-chip and a few external components implement the analog parts.

NSFAX Software package fully supports the SDC. Software drivers handle both the SDC initialization and data transfers.

National Semiconductor's modem software is usually provided in binary form, and hence the internal structure of the SDC is transparent to the user. A detailed description of the SDC is available only for source-level customers.

2.3.2.1 Block Diagram

The Sigma-Delta CODEC block diagram is shown in *Figure 2-4*.

2.0 Architecture (Continued)

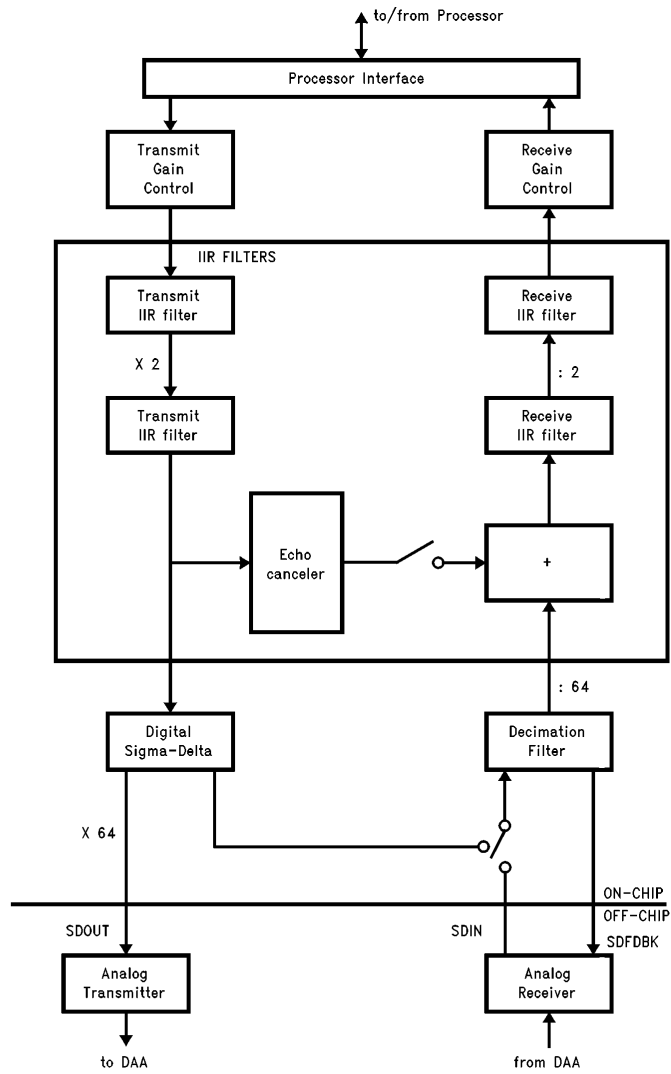

X is the interpolation rate
: is the decimation rate

FIGURE 2-4. Sigma-Delta Block Diagram

TL/EE/11331-9

2.0 Architecture (Continued)

A full Sigma-Delta CODEC includes a digital part and an analog part. The NS32FX100 includes the digital part, and the analog part should be implemented externally.

2.3.2.2 On-Chip Digital Blocks

Sigma-Delta Over Sampling Rate (OSR) is 128 times the Sampling Rate (SR). Some Sigma-Delta blocks use also Double Sampling Rate (DSR).

For communication applications the SR is 9.6 kHz, DSR is 19.2 kHz and the OSR is 1.2288 MHz. For voice applications the SR is 8 kHz, DSR is 16 kHz and the OSR is 1.024 MHz.

DF (Decimation Filter)—Receives 1-bit stream at OSR and decimates it to 16-bit at DSR.

IIR Filters—The IIR filters include Transmission, Reception and Echo-canceller programmable filters. The Echo-cancelling filter can be bypassed.

The Transmission IIR includes two filters. The first filter operates at SR. The second filter interpolates the data rate by two. Thus the filter operates at DSR.

The Reception IIR includes two filters. The first filter operates at DSR and decimates the data rate by two. Thus the second filter operates at SR.

The Echo-canceller filter works at DSR. This filter is used to cancel the echo path.

Receive Gain Control (RGC)—Amplifies or attenuates the received data, to achieve the required signal level, controlled by software Automatic Gain Control (AGC).

Transmit Gain Control (TGC)—Attenuates the transmitted data, to achieve the required signal level, controlled by software Automatic Gain Control (AGC).

Digital Sigma-Delta (DSDM)—Transforms the 16-bit transmitted data at DSR into a 1-bit stream at OSR. A second-order digital Sigma-Delta circuit performs this function.

Processor Interface (PI)—Contains the SDC control and data registers, a 12-level transmission FIFO, a 12-level reception FIFO and a clock divider unit.

2.3.3 Programmable Functions

The Sigma-Delta programming model consists of the following elements:

- IIR coefficients memory
- Data registers
- Control registers

2.3.3.1 Sigma-Delta ON/OFF

The SDC module is enabled by MCFG.ESDC control bit. When MCFG.ESDC is "0" the SDC module is disabled.

The user can access all SDC memory-mapped addresses (IIR coefficients and SDC registers) only while MCFG.ESDC is active. Any attempt to access SDC memory-mapped addresses while MCFG.ESDC is "0" will cause an unpredictable result.

To turn off SDC, turn off receive mode (SDCNTL.RE=0) and transmit mode (SDCNTL.TE=0) and only then clear MCFG.ESDC to "0".

2.3.4 Off-Chip Analog Circuits

The circuit required to connect the SDC on-chip module to a 2-wire line is shown in *Figure 2-5*. The components are detailed in the following table:

TABLE 2-2. Component Values

Component	Value	Tolerance
R1	600Ω	1%
R2	47 kΩ	5%
R3	47 kΩ	5%
R4	47 kΩ	5%
R5	330Ω	5%
R6	330Ω	5%
R7	15.4 kΩ	1%
R8	56 kΩ	5%
R9	100 kΩ	5%
R10	22 kΩ	5%
R11	22 kΩ	5%
R12	56 kΩ	5%
R13	5.1 kΩ	5%
R14	5.6 kΩ	5%
R15	1.0 kΩ	5%
R16	330Ω	5%
R17	330Ω	5%
R18	56 kΩ	5%
C1	0.1 μF	10%
C2	3.3 nF	10%
C3	100 pF	10%
C4	1 nF	10%
C5	22 μF	10%
C6	0.1 μF	10%
C7	22 μF	10%
C8	0.1 μF	10%
C9	47 pF	10%
C10	330 pF	10%
C11	200 pF	10%
C12	22 μF	10%
C13	0.1 μF	10%
C14	22 μF	10%
C15	0.1 μF	10%
C16	100 pF	10%

2.0 Architecture (Continued)

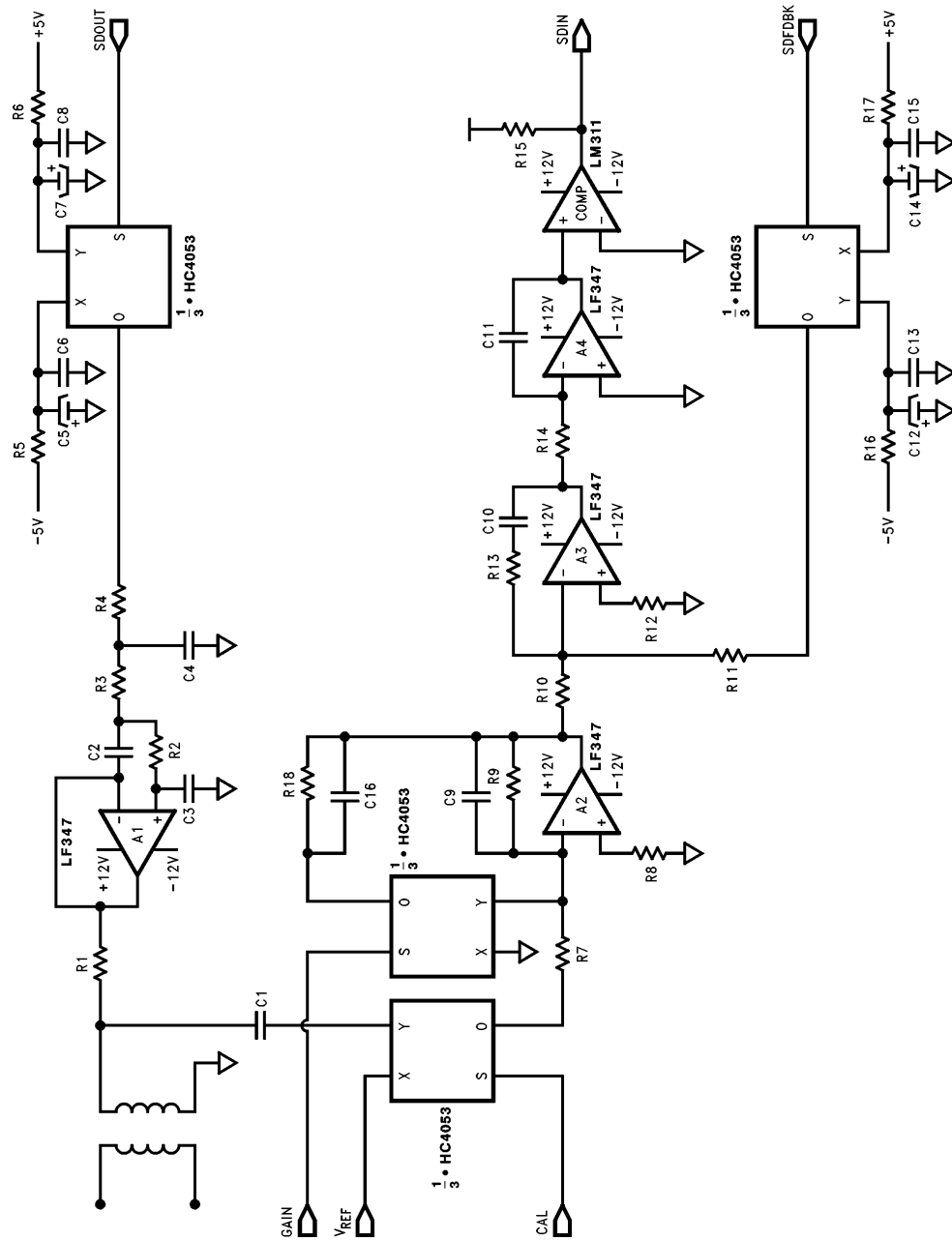

TL/EE/11331-10

FIGURE 2-5. SDC Off-Chip Analog Circuit

2.0 Architecture (Continued)

2.3.4.1 Analog Transmitter

The input to the transmit analog circuit is the serial bit stream at OSR, which is generated by DSDM. This serial bit stream is fed to a 1-bit D/A converter. This D/A converter is implemented by an analog switch, which selects either +5V or -5V inputs. These voltages are filtered by an RC, low-frequency, Low Pass Filter (LPF), to filter supply noise, and to avoid crosstalk between the transmit and receive circuits. The D/A output is filtered, by a three pole LPF with unity gain, to attenuate the out-of-band quantization noise. The output of the LPF passes through a 600Ω resistor.

2.3.4.2 Analog Receiver

The reception analog circuit obtains its analog input signal from an isolation transformer. The signal passes through a buffer amplifier, and then enters the Sigma Delta second order loop. The amplifier has two gain levels. One gain level provides a total gain of 0 dB and the second level provides a total gain of 9 dB. The two gain level are controlled by the GAIN signal.

The Sigma Delta second order loop contains two integrators and a comparator to zero. The comparator output is the SDIN input to the on-chip Sigma Delta part. SDIN is sampled on-chip at OSR, is passed to the digital filters and returns as feedback (SDFDBK pin) to the analog part. This feedback enters a 1-bit D/A converter. This D/A converter is implemented by an analog switch, which selects either +5V or -5V inputs. These voltages are filtered by an RC low frequency LPF, to reduce supply noise, and to avoid crosstalk between the transmit and receive circuits. The feedback is an input to the first integrator unit.

The receiver analog circuit can be calibrated by receiving a known reference voltage. When the circuit is calibrated, the receiver input signal is a known reference voltage (V_{REF}), otherwise the receiver input is the input signal from the isolation transformer.

2.3.5 Registers

The following is a partial list of registers. For a full list see the detailed SD documentation, available to source-level customers.

SDTX Sigma-Delta Transmit Data. This register is the transmit FIFO port. Any attempt to read from this register will cause an unpredictable result.

SDRX Sigma-Delta Transmit Data. This register is the receive FIFO port. Any attempt to write to this register will cause an unpredictable result.

SDCNTL Control register

15	13	12	11	7	6	5	4	3	2	1	0
N/A	N/A	PRES	N/A	TE	N/A	RE	N/A				

Upon reset SDCNTL.PRES is loaded at the minimum pre-scale value in Full-duplex mode, "01001". All other implemented bits of SDCNTL are cleared to "0".

NOTE: Bits marked N/A are available only for source-level customers. For other customers, they must not be modified.

RE Enables or disables receive mode.

0 : Receive mode is disabled.

1 : Receive mode is enabled.

TE Enables or disables transmit mode.

0 : Transmit mode is disabled.

1 : Transmit mode is enabled.

PRES CTTL prescale. The SDC over-sampling rate is generated by dividing the CTTL clock by a pre-scale divider. The PRES value is calculated as follows:

$$PRES = [(CTTL/OSR) - 1].$$

Some examples for sample rate 9.6 kHz and 8 kHz are given below:

SDCNTL.PRES	CTTL Frequency (Sample Rate 9.6 kHz)	CTTL Frequency (Sample Rate 8.0 kHz)
01011	14.7456 MHz	12.2880 MHz
01110	18.4320 MHz	15.3600 MHz
01111	19.6608 MHz	16.3840 MHz
10000	20.8896 MHz	17.4080 MHz
10001	22.1184 MHz	18.4320 MHz
10010	23.3472 MHz	19.4560 MHz
10011	24.5760 MHz	20.4800 MHz

SDFTM Fine Timing register.

7	4	3	2	0
res		ADV	STEP	

STEP Advance or delay steps amount (0-7)

ADV Advance direction

0: Delay mode is enabled

1: Advance mode is enabled

Writing to this register, while SDCNTL.RE is active, is allowed only if SDFTM.STEP is equal to a "0".

Writing to this register, while both SDCNTL.RE is active and SDFTM.STEP is not "0", will cause an unpredictable result.

While SDCNTL.RE is active, this register holds the number of advance or delay steps yet to be executed.

SDRGC Receive Gain Control register. Used to amplify or attenuate the receive IIR output samples. The value to be written in SDRGC register is $128 \times 10^{(Gain/20)}$, rounded to the nearest integer number.

Some examples are given in the following table:

Gain (dB)	SDRGC
-18	0x0010
-17.5	0x0011
.	.
.	.
0	0x0080
0.1	0x0081
.	.
.	.
48.0	0x7D98

2.0 Architecture (Continued)

SDTGC Transmit Gain Control register. Used to attenuate the transmit IIR input samples. The value to be written in SDTGC register is $16384 \times 10(\text{Gain}/20)$, rounded to the nearest integer number.

Some examples are given in the following table:

Gain (dB)	SDTGC
-42	0x0082
-41.9	0x0084
.	.
.	.
0	0x4000

SDSTAT Status Register. Provides information about the status of the Sigma-Delta operation.

7	6	5	4	3	2	1	0
TSAT	RSAT	TFNE	RFNE	TERR	RERR	TIRQ	RIRQ

RIRQ When "1" during receive enable (SDCNTL.RE = 1), it indicates that N or more samples are ready in the receive FIFO. This bit will remain high as long as the number of samples is greater than, or equal to, N. If this bit is not masked by SDMASK.RIRQ it will cause an interrupt.

TIRQ When "1" during transmit enable (SDCNTL.TE = 1), it indicates that less than N samples are ready in the transmit FIFO. This bit will remain high as long as the number of samples is less than N. If this bit is not masked by SDMASK.TIRQ it will cause an interrupt.

RERR When "1" during receive enable (SDCNTL.RE = 1) it indicates an attempt to read an empty receive FIFO, or incoming sample when the receive FIFO is full. If this bit is not masked by SDMASK.RERR it will cause an interrupt.

TERR When "1" during transmit enable (SDCNTL.TE = 1) it indicates an attempt to read from an empty transmit FIFO, or writing to a full transmit FIFO. If this bit is not masked by SDMASK.TERR it will cause an interrupt.

TFNE Transmit FIFO Not Empty, when "0" indicates that the transmit FIFO is empty.

RFNE Receive FIFO Not Empty, when "0" indicates that the receive FIFO empty.

RSAT Reception Saturation. This bit is set to "1", whenever a saturation value is created in the receive IIR (including the echo-canceling filter, when enabled) or in the receive gain control logic.

TSAT Transmit Saturation. This bit is set to "1", whenever a saturation value is created in the transmission IIR or in DSDM.

Upon reset all implemented bits in the SDSTAT register are cleared to "0".

SDMASK Mask Register. Enables masking of SDC interrupts.

7	4	3	2	1	0
res		TERR	RERR	TIRQ	RIRQ

RIRQ Mask Receive Interrupt Request.

0 : SDSTAT.RIRQ will not cause an interrupt.

1 : SDSTAT.RIRQ will cause an interrupt.

TIRQ Mask Transmit Interrupt Request.

0 : SDSTAT.TIRQ will not cause an interrupt.

1 : SDSTAT.TIRQ will cause an interrupt.

RERR Mask Receive Error.

0 : SDSTAT.RER will not cause an interrupt.

1 : SDSTAT.RER will cause an interrupt.

TERR Mask Transmit Error.

0 : SDSTAT.TER will not cause an interrupt.

1 : SDSTAT.TER will cause an interrupt.

2.3.6 Usage Recommendations

The SDC should be enabled (by setting the SDC bit in the MCFG register to "1") before programming SDMASK and SDCNTL.

2.4 SCANNER CONTROLLER (SCANC)

2.4.1 Features

- Programmable generation of control signals which support a wide range of Charge Coupled Device (CCD) and Contact Image Sensor (CIS) scanners
- Supports line scan times of 2.5 ms, 5 ms, 10 ms and 20 ms
- On-Chip shading-correction circuitry, using reference line values stored in the system RAM, via DMA channel 0
- On-Chip dithering and Gamma correction circuit of 16 grey levels. (64 grey levels in NS32FX200)
- Support for Automatic Background Control (ABC) and edge enhancement with external circuitry
- On-Chip multiplying Digital-to-Analog Converter (DAC) for compensation of scanner offset
- Automatic writing of scanned bitmap to memory via DMA channel 2
- Optional bypass of on-chip video-data generation to support external image enhancement

2.4.2 Operation

The Scanner Controller Module (SCANC) consists of a scanner signals generator block, a video handling block (shading compensation, dithering and bitmap accumulation) and a stepper motor control block. The module includes analog and digital circuits. It uses two DMA channels—one for fetching a reference line and one for storing the digitized video data. The module is synchronized with the TCU module. The operation of SCANC, and the allocation of DMA channels 0 and 2 to the Scanner Controller or for external usage, are controlled by the Module Configuration Register (MCFG). The module's minimum operation frequency is 14.7456 MHz (i.e., it can not operate in Power Save mode). Some of the Scanner signals can be assigned to an I/O port when the Scanner is not used (e.g., after reset).

2.0 Architecture (Continued)

2.4.2.1 Scanner Signals Generator Block

This block generates the timing control signals required by CIS and CCD scanners. Scanners with line scan time of 2.5 ms, 5 ms, 10 ms or 20 ms are supported. This period is derived from the TCU module's time-slots (generated by the TCU dividing each 20 ms into 256 time-slots).

The block generates the following signals:

- Scanner Period Pulse (SPP), an internal synchronization pulse.
- Scanner Pixel Clock (SPCLK), an internal pixel clock (its frequency is twice the scanner clock).
- Pixel clocks (two phases—SCLK1 and SCLK2).
- Integrator Discharge Pulse (SDIS).
- Sample and Hold control clock (SNH). Used to sample the scanner analog video signal.

- Scan Line Synchronization Pulse (SLS). Indicates the beginning of a scan line.
- Scanner Comparator Preset, an internal initialization signal for the on-chip analog comparator.
- Active window, an internal time frame that controls the operation of the bitmap generator.
- Peak Detector Window (SPDW). One of the Automatic Background Control (ABC) control signals.
- Scanner interrupt pulse.
- Scanner motor interrupt pulse.

Each signal is generated by an independently programmed waveform generator. The flexible waveform definition facilitates the support of different scanner models.

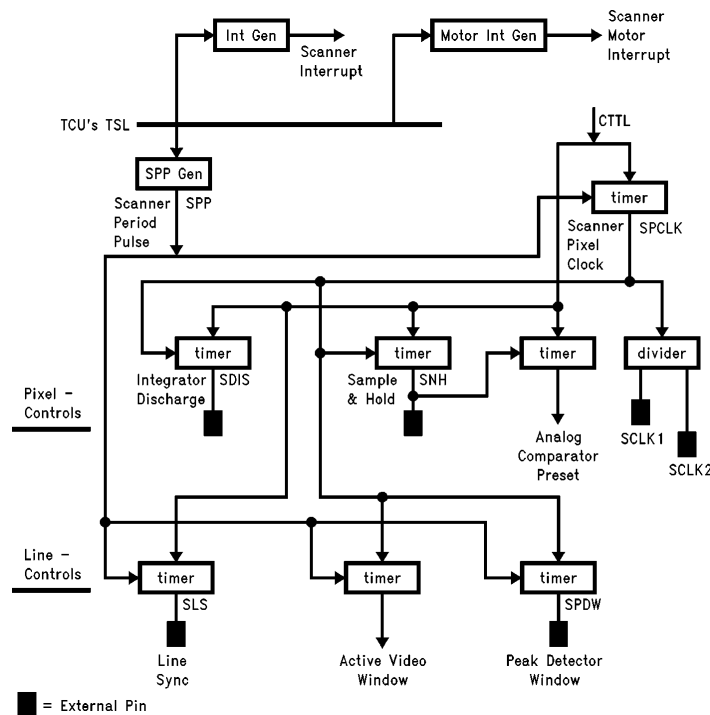

FIGURE 2-6. Block Diagram of Scanner's Signals Generator Block

TL/EE/11331-11

2.0 Architecture (Continued)

2.4.2.2 Scanner Period Pulse (SPP) Generation

The Scanner Period Pulse (SPP) is used to synchronize all the scanner control signals. It is derived from the time slots generated by the TCU module (which divides each 20 ms into 256 time slots).

SPCLK Generation

The internal Scanner Pixel Clock (SPCLK) is generated by dividing CTTL by a programmable prescale value. The result is a video clock which is twice the frequency of the scanner clocks. SPCLK is used for generation of other scanner signals. The value of SPCLK should be determined according to the scanner specification.

The SPCLK pre-scale divider is reset by each SPP leading edge. As a result, the first SPCLK cycle after the SPP may be distorted. Software should program the control registers SAVWD, SLSD and SPDWD so that the first pixel after the SPP is ignored.

SCLK1 and SCLK2 Generation

The two scanner clocks, SCLK1 and SCLK2, are generated by dividing SPCLK by two. SCLK1 is high and SCLK2 is low after SPP leading edge.

SDIS and SNH Generation

The Integrator Discharge Pulse (SDIS) and the Sample-and-Hold Control Clock (SNH) are generated by timers which are clocked by CTTL and triggered by SPCLK. For each of these signals, the polarity, the delay (between SPCLK and its leading edge) and the width are software programmable. The total number of delay and width cycles must not exceed the number of CTTL cycles in one SPCLK period.

Analog Comparator Preset Generation

The Analog Comparator Preset is an internal signal used to initialize the on-chip analog comparator. It is generated by a timer, clocked by CTTL and triggered by SNH leading edge.

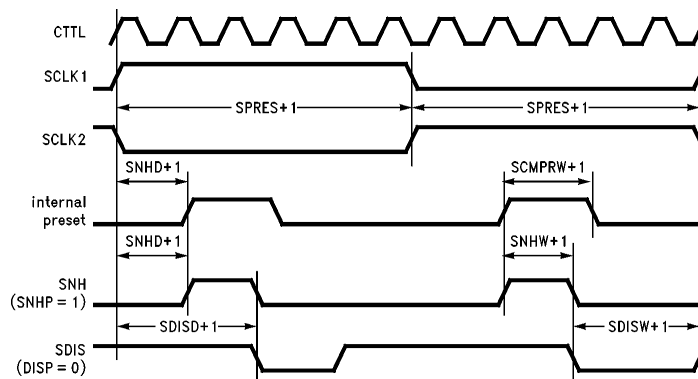

TL/EE/11331-12

Note: In this figure SDIS has inverted polarity (DISP = 0).

FIGURE 2-7. Scanner Pixel Control Signals

2.0 Architecture (Continued)

SLS Pulse Generation

Scan Line Sync (SLS) is generated by a timer according to a calculated delay (in CTTL cycles) from the beginning of the SPP pulse. The delay between the beginning of SPP and the leading edge of SLS, SLS pulse width, and SLS polarity are software programmable.

The first pixel clock after SPP may be distorted. SLS must be programmed so that this pixel is ignored.

Active Video Window and Peak Detector Window Generation

The active Video Window, signaling the valid data window, and the Peak Detector Window, signaling the programmable window for Automatic Background Control, are generated

by timers which are triggered by SPP and clocked by SPCLK.

Scanner Interrupt Generation

The scanner interrupt is a rising-edge interrupt, generated at the beginning of a time slot which is defined by the Scanner Interrupt Time-Slot register (SITSL).

2.4.2.3 Video Handling Block

The Video Handling Block is an Analog-to-Digital convertor for the analog video signal. It enables shading, half-toning and bi-level support with Automatic Background Control (ABC). It also allows pixel generation control, using external circuitry.

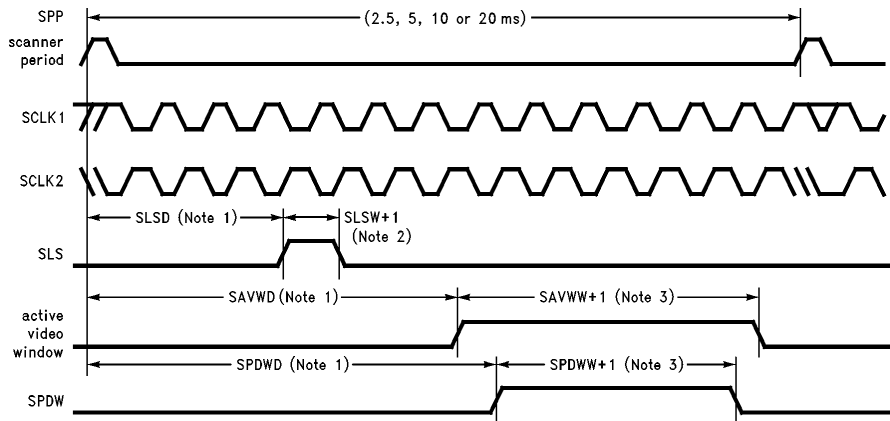

TL/EE/11331-13

Note 1: The delay is controlled by the respective register (SLSW, SAVWD or SPDWD).

Note 2: Measured in CTTL cycles.

Note 3: Measured in SPCLK cycles.

FIGURE 2-8. Scanner Period Control Signals

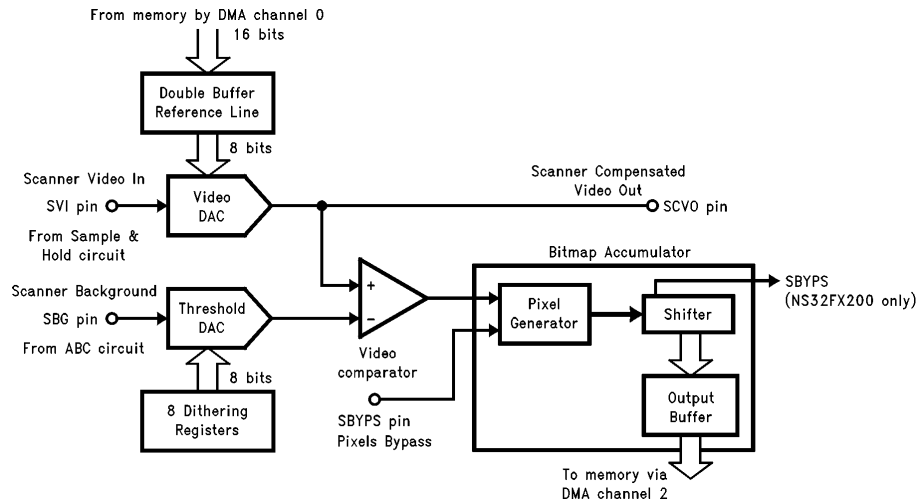

TL/EE/11331-14

FIGURE 2-9. Block Diagram of Scanner's Video Handling Block

2.0 Architecture (Continued)

Video DAC (Shading-Compensation)

The shading-compensation circuit includes an 8-bit multiplying Digital-to-Analog Converter (DAC) that multiplies SVI, the analog input from an external video sample and hold circuit, with a digital reference value (white line) fetched by DMA channel 0. The Video DAC compensates for the input offset, according to the compensation value in the SVDB register, and the control bits in the SVHC register. By writing to the SVDB register, it is possible to control the Video DAC directly by software. In this case, the same 8-bit value replica should be written to both bytes of the register. When the compensation value is greater than the input video signal, the compensated video data signal is "0". The compensated video data, at the output of the video DAC, feeds the video comparator. It also goes to an external pin (SCVO) to enable external implementation of an Automatic Background Control (ABC) circuit.

To enable a longer latency for DMA channel 0 operations, a double buffer is used. DMA cycles are synchronized to the leading edge of SNH during active video window.

When DMA channel 0 is disabled, the same value should be written to both bytes of the Scanner Video DAC Buffer (SVDB) register.

2.4.2.4 Threshold DAC (Dithering and Automatic Background Control)

The dithering circuit includes an 8-bit multiplying DAC that multiplies SBG, the input from an external Automatic Background Control (ABC) circuit, with the digital dither value from one of the eight dither bytes. The threshold DAC has no output pin and no I_{OFF} , internal offset current, but is otherwise similar to the video DAC.

The block includes a cyclic buffer for 64 grey levels. The cyclic buffer contains eight bytes, only one of which is accessible at any given time. Any buffer access (software read, software write or hardware read) causes a cyclic shift in the buffer after the access is completed. A hardware ac-

cess, on SNH leading edge, loads the value of the accessed byte to the DAC's input. Hardware access can take place only during active video window. Software access is carried out via the SDITH register. Software may not access the buffer during active video window. The dither cyclic buffer is shown in *Figure 2-10*. For a gray-level image, ABC should be disabled by externally clamping the SBG input to a constant source. For this purpose, an external analog switch, controlled by any of the Ports module, may be used.

Note: Eight dither registers are available on all system chips. The difference between the number of supported gray levels lies in the different characteristics of the associated analog circuits.

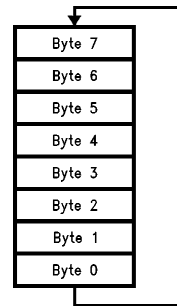

TL/EE/11331-15

FIGURE 2-10. Dither Cyclic Buffer

Video Comparator

The output of the shading-compensation (video) DAC is compared by the video comparator with the output of the dithering (threshold) DAC. The comparator feeds the pixel generator.

Bitmap Accumulator

The bitmap accumulator includes a pixel generator and a bitmap shift register. It uses DMA channel 2 to store the bitmap into memory.

2.0 Architecture (Continued)

Pixel Generator

Pixels may be treated in one of three ways:

- No bypass** The output of the video comparator is an image pixel. It may be inverted by the pixel generator before the pixel is shifted into the bitmap shifter.
- Input bypass** (Available in the NS32FX200 only.) The video comparator output is bypassed, (the video DAC output is taken through the SCVO output pin to an external circuit), and an externally generated pixel is taken as the input to the pixel generator through the SBYP pin.
- Output bypass** (Available in the NS32FX200 only.) As in the No bypass case, the comparator feeds the bitmap shifter. In addition, the last sampled pixel, sampled on the last SNH leading edge and inverted, is driven onto the SBYP pin for optional use by an external circuit (e.g., for edge emphasis).

The operation mode of the pixel generator, in the NS32FX200, is controlled by the Scanner Video Handling Control register (SVHC) and Port C control registers (PCMS, PCEN). It must be configured as "No bypass" in the NS32FX100 and NS32FV100.

No bypass — SVHC.BYPASS = 0 and PCMS.MS4 = 0.

Input bypass — SVHC.BYPASS = 1 and PCMS.MS4 = 1 and PCEN.EN4 = 0.

Output bypass — SVHC.BYPASS = 0 and PCMS.MS4 = 1 and PCEN.EN4 = 1.

Note that the pin output value is unpredictable if the scanner module is disabled (MCFG.ESCAN = 0) while both PCMS.MS4 and PCEN.EN4 are set.

The pixel generator can be configured to invert a pixel before it is shifted.

Bitmap Shifter

The pixel generator output is accumulated and stored into memory via DMA channel 2. Pixels are shifted from left to right i.e. The first pixel in each word is the Least Significant Bit (LSB). The bitmap is double buffered by the Scanner Bitmap Shifter (SBMS) and a word buffer between the scanner module and the DMA channel. The shifter operation is enabled during active window only, and clocked by SNH leading edge. In order to allow software intervention in collecting the scanner's bitmap, the shifter is readable by software.

2.4.2.5 Stepper Motor Control Block

The stepper motor is controlled by four phases. The motor direction and speed is controlled by setting, or clearing, each phase as scanning progresses. The motor is controlled by setting the time-slots in which the phases should be changed (in the SMTSL register). When the set time-slot is reached, an interrupt is generated and the phase values are updated to the values in the phase register (SMPH) in the Ports module.

2.4.3 Registers

- SPRES:** Scanner SPCLK Prescale. 8-bit register. One SPCLK cycle time equals (SPRES + 1) CTTL cycles.
- SDISD:** Scanner Discharge Delay. Write only. 8-bit register. Controls the delay between the edge of SCLK1 and the leading edge of the SDIS signal. The delay is (SDISD + 1) CTTL cycles.
- SDISW:** Scanner Integrator Discharge Pulse Width. Write only. 8-bit register. The width is (SDISW + 1) CTTL cycles.
- SNHD:** Scanner Sample and Hold Delay. Write only. 8-bit register. Controls the delay between the edge of SCLK1 and the leading edge of SNH signal. The delay is (SNHD + 1) CTTL cycles.
- SNHW:** Scanner Sample and Hold Pulse Width. Write only. 8-bit register. The width is (SNHW + 1) CTTL cycles.
- SCMPRW:** Scanner Comparator Preset Pulse Width. Write only. 8-bit register. The width is (SCMPRW + 1) CTTL cycles.
- SLSD:** Scanner Line Sync Delay. Write only. 8-bit register. Controls the delay between the Scanner's Period Pulse (SPP) and the leading edge of the SLS signal.
- SLSW:** Line Sync Pulse Width. Write only. 8-bit register. The width is (SLSW + 1) CTTL cycles.
- SAVWD:** Active Video Window Delay. Write only. 16-bit register. Controls the delay between the leading edge of the Scanner's Period Pulse (SPP) and the beginning of the active video window (number of ignored pixels).
- SAVWW:** Active Video Window Width. Write only. 16-bit register. The width is (SAVWW + 1) SPCLK cycles.
- SPDWD:** Peak Detector Window Delay. Write only. 16-bit register. The delay between leading edge of Scanner's Period Pulse (SPP) and the beginning of peak detector window.
- SPDWW:** Peak Detector Window Width. Write only. 16-bit register. The width is (SPDWW + 1) SPCLK cycles.
- SGC:** Scanner Signals Generator Control register.

2.0 Architecture (Continued)

7	4	3	2	1	0
res		LSPP	PDWP	SNHP	DISP

DISP: Scanner Discharge Pulse Polarity.

- 0: Active low
- 1: Active high

SNHP: Sample and Hold Pulse Polarity.

- 0: Active low
- 1: Active high

PDWP: Peak Detector Window Polarity.

- 0: Active low
- 1: Active high

LSPP: Line Sync Pulse Polarity.

- 0: Active low
- 1: Active high

SPP: Scanner period pulse. 8-bit register.

- 7F: Period pulse each 20 ms (TSL = 255).
- BF: Period pulse each 10 ms (TSL = 255 and 127).
- DF: Period pulse each 5 ms (TSL = 255, 63, 127 and 191).
- EF: Period pulse each 2.5 ms (TSL = 255, 31, 63, 95, 127, 159, 191, 223).

SPP must be programmed with one of these four values, otherwise the period pulse frequency is undefined.

(TSL indicates the appropriate TCU time slot.)

SVHC: Scanner Video handling Control Register.

7	6	5	4	0
res	BYPASS	INVERT	VDILS	

VDILS: Video DAC Input Level Shift.

Number of current steps to be added-to/subtracted-from the input of the Video DAC. This field is encoded as: Sign bit + four magnitude bits. When the input of the video DAC is to be incremented, the sign bit, bit 4, should be set to "1". When it is to be decremented, the sign bit should be "0". Legal values for VDILS are in the range

- 1F ... 10
- 0 ... 0F

INVERT: 0: Pixel not inverted by the pixel generator

- 1: Pixel inverted by the pixel generator

BYPASS: (NS32FX200 only.)

- 0: No bypass. The comparator output is received by the pixel generator.
- 1: Bypass enabled. The SBYP input is selected by the pixel generator and the comparator output is ignored.

Note: Only the NS32FX200 enables bypassing the video comparator output through the SBYP pin. BYPASS must always be cleared to "0" in the NS32FX100 and NS32FV100.

SVDB: Scanner Video DAC Buffer. 16-bit register.

Holds two bytes of compensation values. The lower byte is used first and the upper byte is used for the next pixel.

Normally written by DMA channel 0.

Accessible by software when the DMA channel is either disabled or not allocated to the scanner (i.e., MCFG.EDMA0 = 0).

SBMS: Scanner Bitmap Shifter. Read Only. 16-bit register.

Pixels are shifted from left to right, i.e., the first pixel in each word is the LSB.

SITSL: Scanner Interrupt Time Slot. 8-bit register.

Holds the number of the time-slot in which the scanner interrupt pulse is generated.

SMTSL: Scanner Motor Time Slot. 8-bit register.

Holds the number of the time-slot in which the motor interrupt is generated.

Note: For an event to occur at the beginning of time slot n , the relevant register (SITSL or SMTSL) must be programmed with $n + 1$. If the written value equals the TSL value (the current time slot) then the event will occur either in the next time slot, or after 257 time slots.

Example: If a scanner interrupt is to occur at the beginning of time slot #255 the value: "0" should be written to SITSL.

SDITH: Scanner Dither Cyclic Buffer.

15	8	7	0
accessible byte		res	

The accessible byte is decoded into eight successive address locations. The eight dither values must be initialized before the video active window is reached (the first write for the first pixel).

2.4.4 Usage Recommendations

1. Before activating the Scanner, program the appropriate Ports module registers PBDO, PBMS, PCDO, PCMS and PCEN to connect the Scanner module to the NS32FX100 I/O pins.
2. To activate the Scanner Module, set the ESCAN and ECOUNT bits in the MCFG register.
3. The number of current steps, to be added to the input of the Video DAC, may be initialized by comparing the Video DAC to the appropriate dither value, and using an iterative process to evaluate the required Input Level Shift.
4. The reference line may be initialized, by software, by reading a white line and using an iterative process to evaluate the best value of each pixel's compensation byte.
5. When a scanner with an internal shading-compensation circuit is used, DMA channel 0 is free for external use.
6. DMA channel 2 must be cleared before it can be used, this should be done through 32-bit dummy transactions as follows:
 - a. activate DMA channel 2 for a 4-byte read transaction
 - b. dummy write two words, to ensure that at least two bus cycles occur, thus clearing the channel, read SBMS to clear the shifter counter.
7. The SAVWD, SLSD and SPDWD control registers should be programmed, by software, to ignore the first pixel after SPP.

2.0 Architecture (Continued)

8. The peak detector window may be used to disable the ABC circuit outside the programmed window. The active video window and the peak detector window are configured separately, thus allowing a peak detector window smaller than the active video window.
9. Programming the Pixel Generator bypass control (using SVHC.BYPASS) must be accompanied by an appropriate setup in the Port C control bits, PCMS.MS4 and PCEN.EN4.
10. To prevent loss of pixels by the Bitmap Shifter, the active window should be programmed to allow the accumulation of exactly 16 pixels.
11. Whenever the time-slot set for the stepper motor is reached, the SMPH register in the Ports module should be updated, by software, to hold the phase value of the next change. This should be done in the appropriate interrupt handler code. At the same time, a different time-slot may be set in the SMTSL to control the next stepper motor phase.
12. The NS32FX100 Scanner module should be configured to match the requirements of the scanner device, the external analog circuit and the NS32FX100 analog circuit. The NS32FX100 analog circuit requirements are detailed in Section 4.5.
13. Do not disable the Scanner Controller during Active Window time frame.
14. Access dither registers only outside the active window.

2.5 PRINTER CONTROLLER (PRNTC)

2.5.1 Features

- Interfaces with a variety of Thermal Print-Head (TPH) devices
- Programmable strobe mode, strobe cycle, duty cycle and polarity
- On-Chip TPH temperature sensing circuitry
- Bitmap shift register, using DMA channel 1
- Support for Laser Beam and Ink-Jet engines (NS32FX200 only)

2.5.2 Operation

The NS32FX100 provides a complete interface to TPH devices. The PRNTC operates at a minimum frequency of 14.7456 MHz.

This module is composed of two blocks:

Printer Bitmap Shifter Block

Transfers data to the printer from memory, via DMA channel 1, to the Printer Bitmap Shifter of the PRNTC, from which it is then serially shifted to the printer.

The block's output signals are:

- PCLK (clock)
- PDO (data)

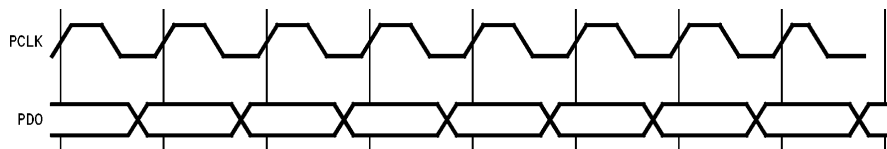

FIGURE 2-11. Bitmap Shifter Signals

TL/EE/11331-16

Thermal Print-Head Block

Controls signals, such as strobes and stepper motor phase signals. It also features a temperature sensing circuit, which receives an indication of the TPH temperature through the PTMP temperature sense pin, and is used by software to control the strobes, ensuring that the TPH does not overheat.

The block's input signal is:

- PTMP (analog temperature)

The block's output signals are:

- STB0-3 (TPH strobes)

2.5.2.1 Printer Bitmap Shifter Block

Data for the printer is first transferred from memory via DMA channel 1, into a 16-bit latch in the Printer Bitmap Shifter. From this latch the data is transferred to a 16-bit shift register, from which it is serially shifted to the printer.

At the beginning of the operation (when PRNTC is enabled by setting the EPBMS bit in the MCFG register), this block issues two consecutive DMA requests—one to fill the shift register and one to fill the latch. Subsequently, whenever the shift register is empty, the latch contents are transferred to it, and a new DMA transfer is requested to refill the latch.

Shift direction is controlled by the SLNR bit of the Printer Bitmap Configuration (PBCFG) register. Actual bitmap shift takes place according to the ECLK bit of the PBCFG register, using either an internal or an external clock, (in the NS32FX100 and NS32FV100 this bit is always "0" and the shifting always uses an internal clock). Data is always shifted out, when the shifter is not empty, on clock falling edge. When an internal clock is used, the clock signal is high when there is no available data to shift out.

An internal clock is used for Thermal Print-Heads.

An external clock is recommended for Laser Beam Printers since video (pixels) left margin, active time and polarity are externally synchronized with the printer engine.

The frequency of the external clock should be in the range 0.5 MHz to 4 MHz.

2.5.2.2 Thermal Print-Head Control Block

This block generates the printer stepper motor phase signals, the printer strobes, and the printer interrupt. Its operation is synchronized with the TCU time slots, and is fully controlled by software.

Stepper Motor Controller

The stepper motor is controlled by four phases. The motor direction and speed is controlled by setting, or clearing, each phase as printing progresses. The motor is controlled by setting the time-slots in which the phases should be changed (in the PMTSL register). When the set time-slot is reached, an interrupt is generated and the phase values are updated to the values in the phase register (PMPH) in the Ports module.

2.0 Architecture (Continued)

Strobes Generator

A train of strobes consists of two or four strobes depending on the strobes mode. The train of strobe pulses starts on the time slot pre-defined in the Printer Strobes-Start Time Slot (PSTSL) register. The train of strobe pulses starts with a strobe-on interval, followed by a sequence of strobe-off and strobe-on intervals. The duration of the strobe-on interval is controlled by the STBON register and the duration of the strobe-off interval is controlled by the STBOFF register. The strobe-on and strobe-off intervals may be programmed while the strobe pulses are being generated. After the last strobe-on interval is completed, a Strobes-Done interrupt pulse is generated. The interrupt is periodic, occurring when the pre-defined time slot is reached and the train of strobe pulses is completed.

Strobing pulses are generated on the STB0–3 output pins, if enabled by the STBEN bit of the Thermal Print-Head Control (TPHC) register. After the last strobe-on interval is completed, the STBEN bit is automatically cleared by hardware. To prevent losing strobe pulses, the software should verify that the bit is cleared before setting it to “1”.

The strobing mode defines both the number of strobes in a train and the distribution of strobes among the STB0–3 pins. Two strobing modes are supported, Two-Strobes mode and Four-Strobes mode. The Strobe Mode (STBM) field of the TPHC register selects the strobing mode to be used.

The two strobing modes are shown in *Figure 2-12* and *Figure 2-13* for TPHC.SPOL = 1. Note that “Start” is the beginning of the time slot and “Done” is the Strobes-Done event.

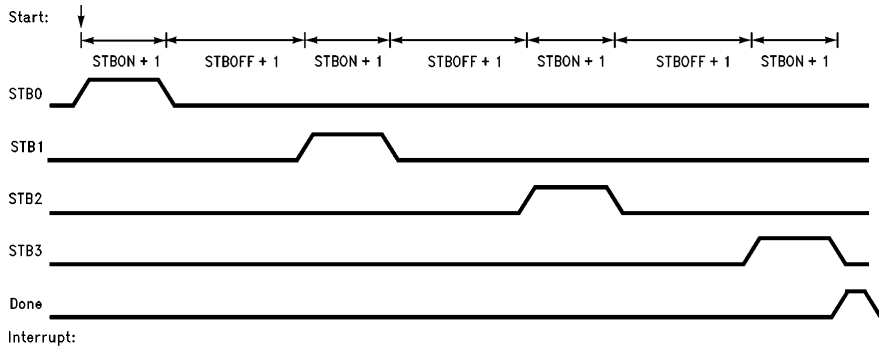

FIGURE 2-12. Four Strobes Mode (STBM = 00)

TL/EE/11331-17

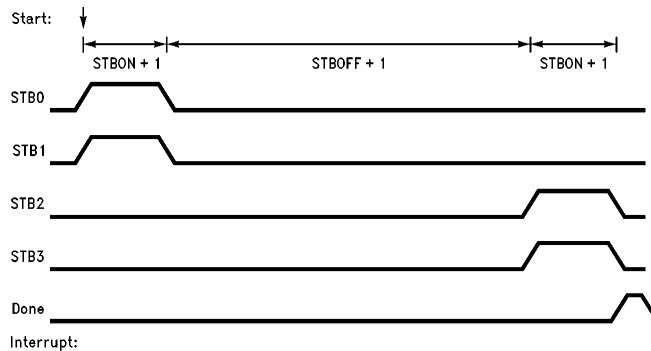

FIGURE 2-13. Two Strobes Mode (STBM = 01)

TL/EE/11331-18

2.0 Architecture (Continued)

Printer Interrupt Generator

The Interrupt Control Unit dedicates one interrupt either to the Strobes-Done pulse or to DMA channel 1. The Printer Interrupt Source (PIS) bit of the TPHC register selects which of the interrupt pulses is routed to the Interrupt Control Unit.

Temperature Sensing Circuit

A 6-bit A/D Converter (ADC) is implemented by a 6-bit Pulse Width Modulation (PWM) based D/A converter and an analog comparator. The control loop of the ADC is executed under software control. The total time for both PWM based D/A conversion and for comparator settling is less than 2 ms. The DAC must be initialized to 011111 at least 10 ms prior to the first reading of the comparator output.

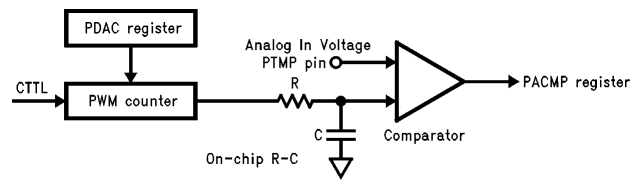

FIGURE 2-14. Temperature ADC

TL/EE/11331-19

2.0 Architecture (Continued)

2.5.3 Registers

PBCFG: Printer Bitmap Shifter Configuration register.

7	2	1	0
res	SLNR	ECLK	

ECLK: External Clock. (NS32FX200 only.)
 0: Shift using an internal clock. Clock frequency is selected by the printer bitmap internal clock generator.
 1: Shift using an external clock.

The external clock must be frozen at least four instructions after both DMA channel 1 and the Bitmap Shifter are enabled (i.e., MCFG.EPBMS = 1).

Note: Only the NS32FX200 supports operation using an external clock. ECLK must always be cleared to "0" in the NS32FX100 and NS32FV100.

SLNR: Shift direction.
 0: Shift right (LSB first)
 1: Shift left (MSB first)

PBCFG may not be written while MCFG.ETPHB = 1. It should be configured before printer activation.

PCLON: Printer Bitmap Shifter internal clock (PCLK) high time. 8-bit register.
 PCLK is high for (PCLON + 1) CTTL cycles.
 PCLON may be modified only when MCFG.EPBMS = 0.

PCLOFF: Printer Bitmap Shifter internal clock (PCLK) low time. 8-bit register.
 PCLK is low for (PCLOFF + 1) CTTL cycles.
 PCLOFF may be modified only when MCFG.EPBMS = 0.

TPHC: Thermal Print-Head Control register.

7	5	4	3	2	1	0
res	STBEN	PIS	SPOL	STBM		

STBM: Strobing mode (see *Figure 2-12* and *Figure 2-13*).
 00: Four strobos
 01: Two strobos
 10: Reserved
 11: Reserved

SPOL: Strobos polarity.
 0: Active low strobe-on
 1: Active high strobe-on

PIS: Printer Interrupt Source.
 0: Strobos done interrupt pulse
 1: DMA channel 1 interrupt pulse

STBEN: Strobos Enable.
 Set by software to enable strobe generation on strobe pins STB0–3. Automatically cleared by hardware after the last strobe-on interval is completed. To avoid losing strobe pulses, verify that this bit is cleared before setting it to "1".

Upon reset the non-reserved bits of TPHC are cleared to "0".

STBON: Strobe-On. 16-bit register.
 The strobe-on interval is (STBON + 1) MCLK cycles.

STBOFF: Strobe-Off. 16-bit register.
 The strobe-off interval is (STBOFF + 1) MCLK cycles.

PSTSL: Printer Strobos Start Time Slot. 8-bit register.
 Holds the time slot in which the strobe pulse train starts.

PMTSL: Printer Motor Time-Slot. 8-bit register.
 Holds the time slot in which the Printer Motor Interrupt Pulse is generated. The interrupt pulse occurs at the beginning of the specified time slot.

Note: For an event to occur at the beginning of time slot n, the relevant register (PSTSL or PMTSL) must be set to the value n + 1. If the written value equals the TSL value the current time slot) then the event will occur either in the next time slot, or after 257 time slots.

Example: If a printer interrupt is to occur at the beginning of time slot #255 write the value "0" to PSTSL.

PDAC: Printer PWM Pulse Width Modulation DAC.

7	6	5	0
res	PDAC		

The PWM signal duty cycle is (PDAC + 1)/64.

The signal width is zero when PDAC = 3F.

PACMP: Printer Analog Comparator Status. 8-bit register.
 Read only.
 Bit 0:

1: DAC voltage > PTMP pin voltage.
 0: DAC voltage < PTMP pin voltage.

Bits 1–7: Reserved.

2.5.4 Usage Recommendations

- Before activating the Printer, program the appropriate Ports module registers PBDO, PBMS, PCDO, PCMS and PCEN to connect the Printer module to the NS32FX100 I/O pins.
- Completion of the Printer Bitmap Shifter operation is indicated either through the STROBE-DONE interrupt or through the DMA COUNTER-DONE status bit (STAT.TC is set to "1"). If indicated by the DMA STAT.TC bit, 32 additional bits must be explicitly shifted out of the Bitmap Shifter, to complete the DMA transfer.
- When TPHC.STBEN = 0, strobos are still generated internally, hence the Strobos-done interrupt can still be used even when strobos are disabled.
- When using the Bitmap Shifter with an external clock the operation must be carried out in the following order:
 - Initialize the ports module to work with the printer using an external clock (ports B and C).
- Disable the strobos (TPHC.STBEN = 0) before disabling the TPH module (MCFG.ETPHB = 0).

2.0 Architecture (Continued)

- b. Initialize the PRNTC module to work with an external clock.
- c. Initialize DMA channel 1 registers without enabling the channel (set CNTL1.CHEN = 0).
- d. Set MCFG.ECOUNT, and MCFG.EPBMS to "1" to enable the PRNTC module.
- e. Set CNTL1.CHEN to "1" to enable DMA channel 1.
- f. Issue at least four instructions (may be NOPs).
- g. Enable the external clock operation.

2.6 DIRECT MEMORY ACCESS CONTROLLER (DMAC)

2.6.1 Features

- Four independent channels in NS32FX200, three in NS32FX100 and NS32FV100
- Single and double buffering, and auto-initialize modes
- Fly-By or memory-to-I/O transactions
- 8- or 16-bit wide transactions
- Maximum throughput 12.5 Mbyte/second
- Channels configurable as internal or external

2.6.2 Description

The DMA Controller (DMAC) provides independent channels for transferring blocks of data between memory and I/O devices with minimal CPU intervention. A block transfer is composed of several byte or word transfers.

A general DMA channel, with eight registers and a superset of features, is described first. Any on-chip DMA channel is either similar to, or a subset of, this general channel. The four NS32FX200 DMA channels, and the three NS32FX100 and NS32FV100 DMA channels, are described after the description of the general DMA channel.

2.6.2.1 A General DMA Channel

Memory address, block size and type of operation are set up prior to DMA activation by programming the appropriate control registers. Actual byte or word transfers are handled by the DMA channel in response to I/O device requests. Upon receiving a transfer request from an I/O device, the DMA Controller performs the following operations:

1. Acquires control of the bus (via \overline{HOLD} , $\overline{HLD\bar{A}}$ mechanism).
2. Acknowledges the requesting I/O device, or one of several requesting I/O devices, according to the priority and to the values stored in the control registers of the respective channel.
3. Executes the data transfer.
4. Updates the termination status bit (TC bit of the STAT register) when the specified number of bytes has been transferred.

2.6.2.2 Transfer Types

Each byte or word transfer can be carried out as one of the following two types:

Fly-By (Direct) Transfers

In Fly-by mode each data item is transferred using a single bus cycle without reading the data into the DMA Controller. This mode offers the fastest transfer rate. Data transfer cannot occur between two memory elements. One of the elements must be the I/O device that requested the DMA

transfer. This device is referred to as the implied I/O device. The other element can be either memory or another I/O device, and is referred to as the addressed device. The number of bytes transferred in each cycle is always two. Fly-by DMA transactions are word aligned; device address and block length must be even numbers. DMA transfers are controlled by the DMA module registers. A detailed description of the DMA operation is provided in Section 2.6.3.

Memory-to-I/O (Indirect) Transfers

In Memory-to-I/O mode each data item is transferred using two bus-cycles. Data transfer cannot occur between two memory elements. One of the elements must be the I/O device which requested the DMA transaction. This device is referred to as the implied I/O device and is 8-bits wide. The other element can be either memory or another I/O device, is referred to as the addressed I/O device and is 16-bits wide. The DMA controller takes care of both byte gathering and scattering. DMA transfers are controlled by the DMA module registers. A detailed description of the DMA operation is provided in Section 2.6.3. Memory-to-I/O transfers are available only through channel 3.

2.6.2.3 Operation Modes

Each block transfer can be carried out in one of three modes:

- Single Buffer Mode provides the simplest way to accomplish a single block transfer operation. It performs one DMA block transfer, and, when the transfer is completed, prepares the specifications for the next transfer.
- Double Buffer Mode allows the software to set up the next block-transfer specification while the current block-transfer is in progress.
- Auto-Initialize Mode allows the DMA Controller to continuously fill the same memory area without software intervention.

A detailed description of the various modes of operation is provided in Section 2.6.3.

2.6.3 Detailed Operation Flow

The DMA operation is controlled through the DMA registers. The flow of the various DMA operations, using different registers for each transfer type and operation mode, is detailed below:

Fly-By Operation

The address for the Fly-by mode is taken from the ADCA counter register. The DMA channel generates either a read or a write bus cycle according to the setting of the transfer direction (DIR) bit in the MODE register. When the DIR bit is "0", a read bus-cycle from the addressed device is performed and the data is written to the implied I/O device. When the DIR bit is "1", a write bus-cycle to the addressed cycle is performed, and the data is read from the implied I/O device. After the two bytes have been transferred, the Block Length Counter (BLTC) is decremented by two. The Device Address Counter (ADCA) is incremented or decremented by two, or remains unchanged, according to the Decrement/Increment (DEC) and Device Address Control (ADA) bits in the MODE register.

2.0 Architecture (Continued)

Memory-to-I/O Operation

The data is first read from the source into the DMA Controller, and is subsequently written to the destination. When the DIR bit is "0", the first bus-cycle is used to read data from the addressed device according to the ADCA counter, while the second bus-cycle is used to write the data into the implied I/O device according to the Implied I/O Device (ADRB) register. When the DIR bit is "1", the first bus-cycle is used to read data from the implied I/O device using the ADRB register, while the second bus-cycle is used to write the data into the addressed device according to the ADCA counter. The number of bytes transferred in each cycle is always one. After the byte has been transferred, the BLTC counter is decremented by one. The ADCA counter is incremented or decremented by one, or remains unchanged, according to the DEC and ADA bits in the MODE register. ADRB is not changed.

Single Buffer Mode Operation

The block-transfer addresses and byte count should be first written into the corresponding ADCA and BLTC counters and the ADRB register. The Operator Type (OT) bit in the MODE register should be programmed for non auto-initialize mode, and the next Transfer Parameter Valid (VLD) bit in the CNTL register should be cleared to "0". When the Channel Enabled (CHEN) bit in the CNTL register is set to "1", the channel becomes active and responds to the transfer requests. When the BLTC counter reaches 0, the transfer operation terminates. The TC and Channel Overrun (OVR) bits in the STAT register are set to "1" and Channel Active (CHAC) is cleared to "0". If enabled through the ETC bit, a Terminal Count (TC) interrupt pulse is generated. If the EOVR bit in the STAT register is "1", the CHEN bit in the CNTL register is forced to "0".

Double Buffer Mode Operation

The operation is initiated by writing the block-transfer address and byte count into the ADCA and BLTC counters and ADRB register, then programming the OT bit in the MODE register for non auto-initialize mode. When the CHEN bit in the CNTL register is set to "1", the channel becomes active and responds to transfer requests. While the current block-transfer is in progress, the software can write the address and byte count for the next block into the ADRA and BLTR registers, respectively, and then set the VLD bit in the CNTL register to "1". When the BLTC counter reaches 0, a TC interrupt pulse is generated, if enabled, through the ETC bit. The TC bit is set to "1" and the DMA channel checks the value of the VLD bit. If it is "1", the channel copies ADRA and BLTR values into ADCA and BLTC, respectively, clears the VLD bit and starts the next block transfer. If the VLD bit is "0", the channel sets the OVR bit in the STAT register to "1", clears the CHAC bit and, if the EOVR bit in the STAT register is "1", it forces the CHEN bit to "0".

Auto Initialize Mode Operation

The operation is initialized by writing the block address and byte count values into the ADCA and BLTC counters and into the ADRA, ADRB and BLTR registers, and programming the OT bit in the MODE register for auto-initialize mode. When the CHEN bit in the CNTL register is set to "1", the channel becomes active and responds to DMA re-

quests. When the BLTC counter reaches 0, a TC interrupt pulse is generated, if enabled, through the ETC bit. The TC bit in the STAT register is set to "1" and the contents of the ADRA and BLTR registers are copied to the ADCA and BLTC counters, respectively. The operation is repeated.

2.6.4 NS32FX200 DMA Channels

This section refers to the NS32FX200 since it has four DMA channels, while the NS32FX100 and NS32FV100 have only three. All references to channels 0–2 are applicable to all chips. All references to channel 3 are applicable to the NS32FX200 only.

Channel 0 is for the scanner reference line fetches (write to SVDB).

Channel 1 is for the printer bitmap fetches.

Channel 2 is for the scanner digitized-video writes.

Channel 3 is for external use.

Each of these three channels may be used as a general purpose external DMA channel instead of the above mentioned use. This is done by the MCFG register. An external DMA channel is accessible externally, via the Ports module. Both MCFG bits and Port's MS bits must be configured to enable these DMA channels.

All the channels include STAT, ADCA, BLTC, MODE and CNTL registers. Channels 1 and 3 support double buffer operations, and include ADRA and BLTR registers. Channels 0–2 support only Fly-By (Direct) DMA transactions. Channel 3 supports both Memory-to-I/O and Fly-By DMA transactions and, therefore, includes an ADRB register.

Channel 0 has the highest priority, followed by channel 1, channel 2, and, with lowest priority, channel 3. Refresh has higher priority than DMA and it may occur between the two bus transactions of a non fly-by DMA transaction. Priority is resolved when the bus is idle, or on the last T3 of both CPU and DMA transactions.

2.6.5 Registers

A DMA channel contains a set of eight registers. These registers are listed by their generic names. The DMA channel number should be added as a suffix to the register name when referring to a specific channel register (e.g., ADCA0, ADCA1).

The registers ADCA, BLTC, STAT and MODE must be set before activating the appropriate channel. Undefined results are obtained when these registers are written while the channel is enabled. Upon reset STAT and CNTL are cleared to "0".

MODE Mode Control register. This register is used to specify the channel operating mode.

15	10	9	8	4	3	2	1	0
res	ADA	res	DIR	NFBY	DEC	OT		

OT Operation Type, for channels 1, 3 only (for channels 0, 2: reserved).

0 : Auto-Initialize mode disabled

1 : Auto-Initialize mode enabled

2.0 Architecture (Continued)

- DEC** Decrement/Increment update of ADCA.
 0 : ADCA incremented after each transfer cycle (if ADA = 1).
 1 : ADCA decremented after each transfer cycle (if ADA = 1).
- NFBY** Fly-By/Memory-to-I/O Transfers, for channel 3 only (for channels 0, 1, 2: reserved).
 0 : Fly-By
 1 : Memory-to-I/O
- DIR** Transfer Direction.
 Specifies the direction of the transfer between memory and implied I/O device.
 0 : Implied I/O Device is Destination
 1 : Implied I/O Device is Source
- ADA** Device Address Control. Controls the update of the ADCA counter after each transfer cycle.
 0 : ADCA address unchanged
 1 : ADCA address updated
- ADCA** Device Address Counter. 32-bit register.
 Bits 0–23 : Hold the current address of either the source data item or the destination location in the Addressed Device.
 Bits 24–31 : Reserved.
 If the ADA bit in the MODE register is set to “1”, ADCA is updated, according to DEC and FBY bits in MODE register, after every DMA transfer.
- ADRA** Device Address Register. 32-bit register. (Channels 1 and 3 only)
 Bits 0–23 : Hold the starting address of the next block to be transferred of either the source data block or the destination data area of the Addressed Device.
 Bits 24–31 : Reserved.
- ADRB** Implied I/O Device register. 32-bit register. (Channel 3 only)
 Bits 0–23 : Hold the address of either the source data block or the destination data area of the implied I/O device.
 Bits 24–31 : Reserved.
- BLTC** Block Length Counter. 32-bit register.
 Bits 0–23 : Hold the current number of bytes to be transferred.
 Bits 24–31 : Reserved.
 BLTC is decremented, after each transfer, according to FBY bit in MODE register.
- BLTR** Block Length Register. 32-bit register. (Channels 1 and 3 only)
 Bits 0–23 : Hold the number of bytes in the next block to be transferred.
 Bits 24–31 : Reserved.
 A “0” value in the BLTR register, while the VLD and CHEN in the CNTL register are both set to “1”, may cause unpredictable results.

STAT Status register. This register has two functions:
 Holds status information for the DMA channel.
 Used to enable or mask the DMA interrupts for the various terminations conditions.

7	6	5	4	3	2	1	0
Res	EOVR	res	ETC	CHAC	OVR	res	TC

- TC** Terminal Count.
 When set to “1” indicates that the transfer was completed by a terminal count condition (BLTC reached 0).
- OVR** Channel Overrun. (Channels 1, 3 only)
 Set to “1”, in non auto-initialize mode, when the present transfer is completed (BLTC = 0), but the parameters for the next transfer are not valid (VLD bit in CNTL is “0”).
- CHAC** Channel Active. Read Only.
 When set to “1”, indicates that the channel is active (CHEN bit in CNTL register is “1” and BLTC > 0).
 This bit continuously reflects the active or inactive status of the channel, and therefore, can only be read. Data written to the CHAC bit is ignored.
- ETC** Enables interrupt pulse when the BLTC counter reaches 0.
 0 : Disable
 1 : Enable
- EOVR** Enables interrupt pulse when OVR bit is set. (Channels 1, 3 only)
 0 : Disable
 1 : Enable

The TC and OVR bits are sticky. This means that once set by the occurrence of the specific condition, they will remain set until explicitly cleared by software. Those bits can be individually cleared by writing a value into the STAT register with the bit positions to be cleared set to “1”. Writing “0” to those bits has no effect.

CNTL Control register.
 This register is used to synchronize the channel operation with the programming of the block transfer parameters.

7	2	1	0
res		VLD	CHEN

- CHEN** Channel Enable.
 0 : Channel Disable
 1 : Channel Enable
 The CHEN bit is cleared to “0” in the following cases.
 (1) Upon Reset
 (2) Software clears it by writing to the CNTL register.

2.0 Architecture (Continued)

- (3) The OVR bit in the STAT register is set to "1" and the EOVR bit is "1". In the last case the CHEN bit is forced to "0" and cannot be set to "1" by software unless the OVR is either cleared or masked by clearing the EOVR bit in the STAT register.

VLD Transfer Parameter Valid. Indicates whether the transfer parameters for the next block to be transferred are valid. The VLD bit is ignored in auto-initialize operation mode and is cleared by hardware

after ADRA and BLTR have been copied to ADCA and BLTC respectively. VLD is used to distinguish between single transfer and double-buffer operation modes.

2.6.6 Usage Recommendations

1. Before activating the DMA, program the appropriate Ports module registers PBDO, PBMS, PCDO, PCMS and PCEN to connect the DMA to the NS32FX100 I/O pins.
2. Set the MCFG register to allocate the DMA channels as either internal or external, as appropriate.
3. The Ports module must be configured to allow the allocation of the I/O pins to the DMA channels.

2.6.7 DMAC Bus Cycles

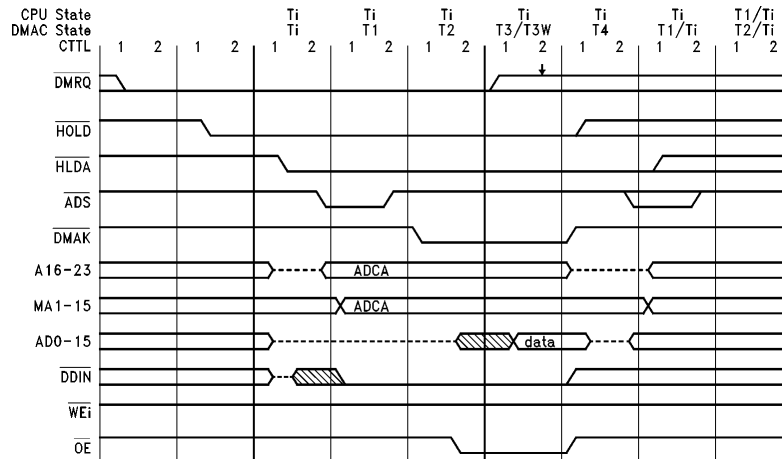

FIGURE 2-15. DMA Fly-By Read Transaction (DIR = 0, NFBY = 0)

The maximum throughput of a DMA channel is 12.5 Mbyte/sec. (Two bytes can be transferred at a rate of four CTTL cycles per transfer, up to 25 MHz.)

Note 1: Memory control signals (like $\overline{\text{CWAIT}}$, select and write enable) are generated according to the specifications of the accessed zone.

Note 2: A ↓ in the figure indicates DMA priority resolving points.

2.0 Architecture (Continued)

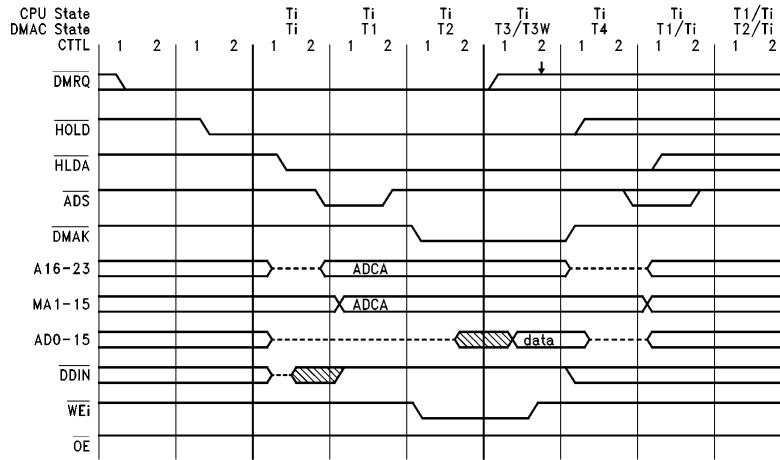

TL/EE/11331-21

FIGURE 2-16. DMA Fly-By Write Transaction (DIR = 1, NFBY = 0)

The maximum throughput of a DMA channel is 12.5 Mbyte/sec. (Two bytes can be transferred at a rate of four CTTL cycles per transfer, up to 25 MHz.)

Note 1: Memory control signals (like \overline{CWAIT} , select and write enable) are generated according to the specifications of the accessed zone.

Note 2: The NS32FX100 does not drive data onto AD0-15 till the end of T4 in memory \leftrightarrow I/O transactions (like NS32FX100 register read transactions).

Note 3: A \downarrow in the figure indicates DMA priority resolving points.

2.0 Architecture (Continued)

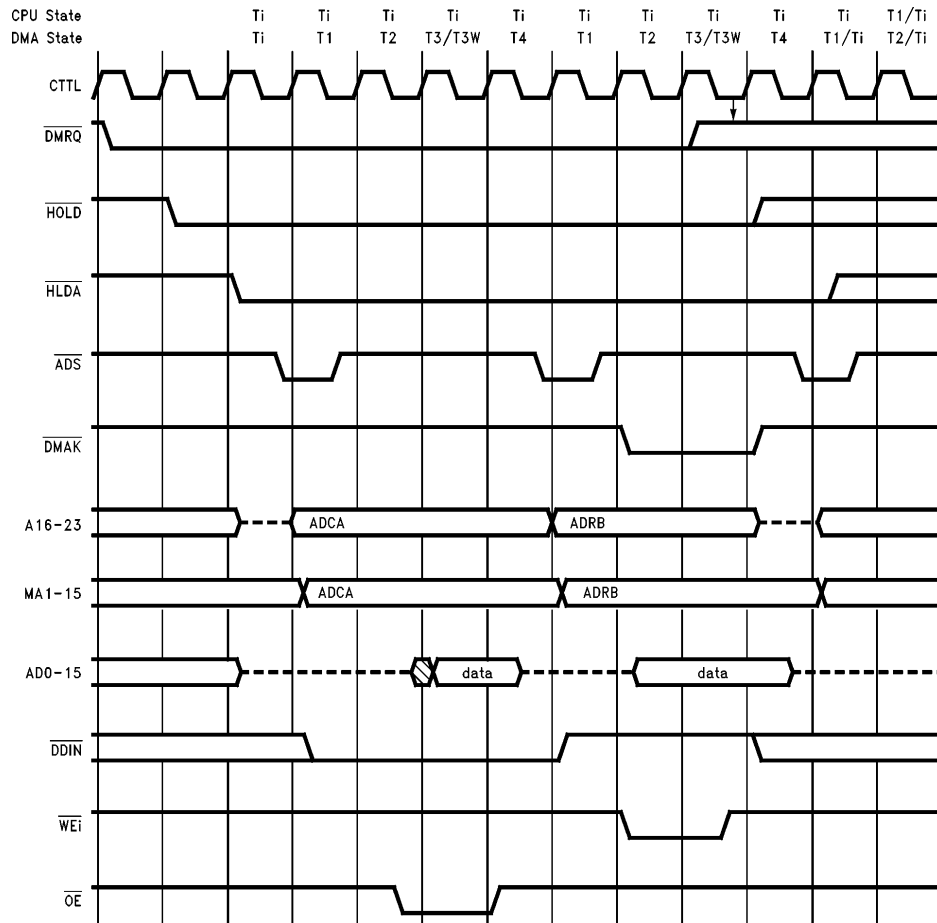

TL/EE/11331-22

FIGURE 2-17. DMA Memory to I/O (Indirect) Read Transaction (DIR = 0, NFBY = 1)

The maximum throughput of a DMA channel is 3.125 Mbyte/sec. (One byte can be transferred at a rate of eight CCTL cycles per transfer, up to 25 MHz.)

Note 1: Memory control signals (like \overline{CWAIT} , select and write enable) are generated according to the specifications of the accessed zone.

Note 2: The NS32FX100 does not drive data onto AD0-15 till the end of T4 in memory \leftrightarrow I/O transactions (like NS32FX100 register read transactions).

Note 3: A \downarrow in the figure indicates DMA priority resolving points.

2.0 Architecture (Continued)

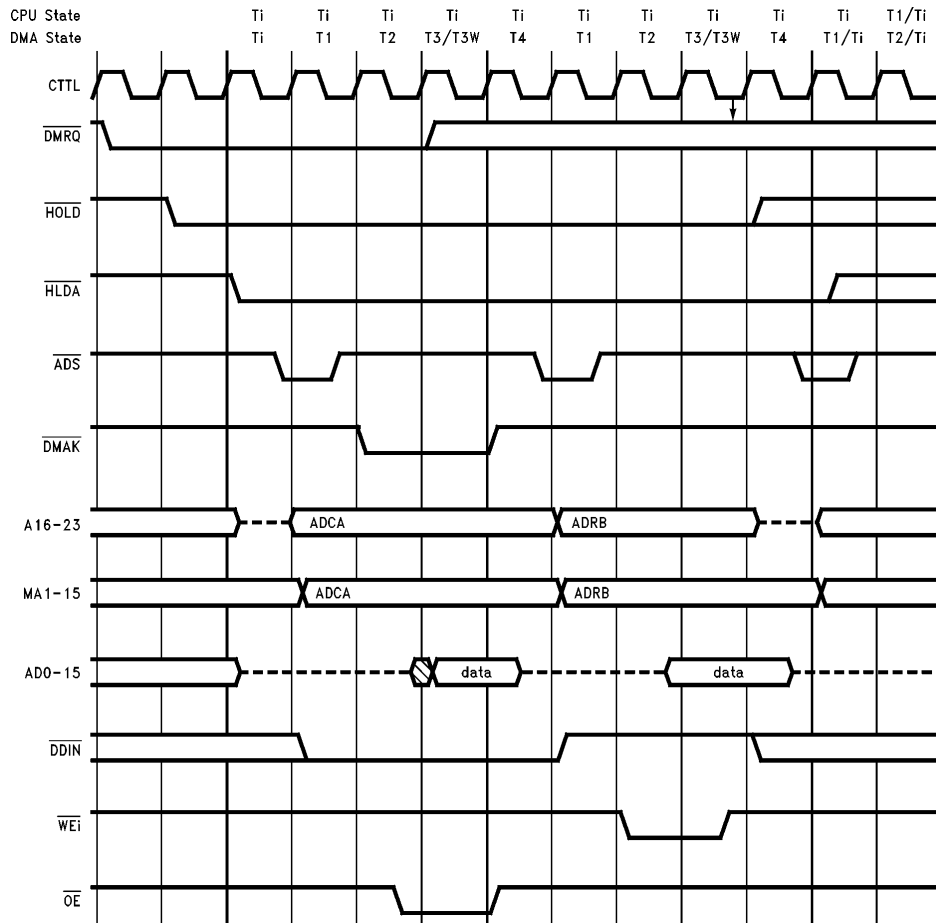

TL/EE/11331-23

FIGURE 2-18. DMA I/O to Memory Write Transaction (DIR = 1, NFBY = 1)

The maximum throughput of a DMA channel is 3.125 Mbyte/sec. (One byte can be transferred at a rate of eight CTTL cycles per transfer, up to 25 MHz.)

Note 1: Memory control signals (like \overline{CWAIT} , select and write enable) are generated according to the specifications of the accessed zone.

Note 2: The NS32FX100 does not drive data onto AD0-15 till the end of T4 in memory \leftrightarrow I/O transactions (like NS32FX100 register read transactions).

Note 3: A \downarrow in the figure indicates DMA priority resolving points.

2.0 Architecture (Continued)

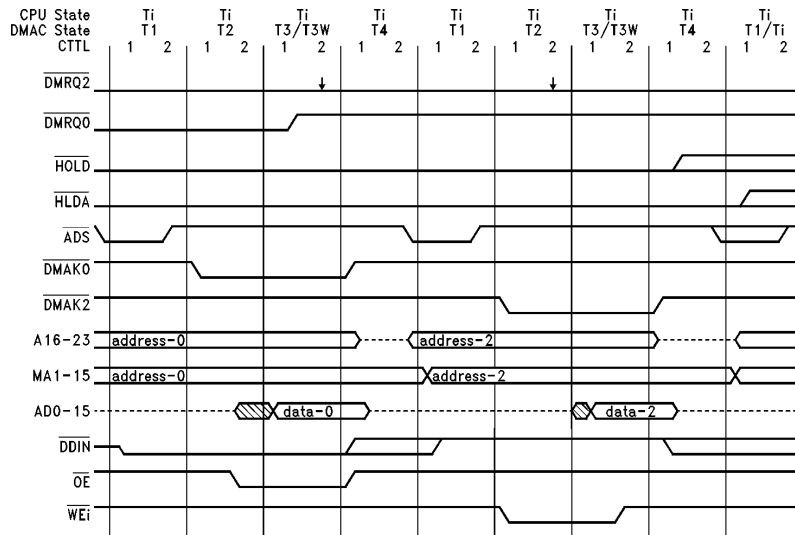

TL/EE/11331-24

FIGURE 2-19. Two Adjacent Fly-By DMA Transactions

The maximum throughput of a DMA channel is 12.5 Mbyte/sec. (Two bytes can be transferred at a rate of four CTTL cycles per transfer, up to 25 MHz.)

Note 1: Memory control signals (like $\overline{\text{CWAIT}}$, select and write enable) are generated according to the specifications of the accessed zone.

Note 2: A ↓ in the figure indicates DMA priority resolving points.

2.7 UNIVERSAL ASYNCHRONOUS RECEIVER-TRANSMITTER (UART)

2.7.1 Features

- Full duplex double-buffered transmitter/receiver
- Programmable baud rate between 300 and CTTL/32 baud
- Hardware flow control
- Asynchronous 7-bit or 8-bit character transmission/reception
- Supports transmission of one or two stop bits
- Hardware support of odd or even parity-bit generation during transmission
- Hardware support of odd or even parity check during reception
- Maskable interrupt on transmit ready or receive ready, regardless of reception errors
- Data sampled at 16 times the baud rate
- Software-controlled break transmission and detection

2.7.2 Operation

The Universal Asynchronous Receiver Transmitter (UART) module enables the NS32FX100 to communicate with standard serial devices using three communication signals: transmit, receive and ground. A character is composed of a start bit followed by data bits (the least significant bit right after the start bit) followed by an optional parity bit and at least one stop bit. The communication is serial—the transmit and receive signals hold one bit at a time. Bit duration is one baud time.

The UART can be configured with the following communication parameters: 7-bit or 8-bit data formats, with or without parity, with one or two stop bits.

Baud rate is generated internally, by dividing CTTL under software control. Break is generated under software control. Break detection is via the frame error status bit (UCLST.FE).

The UART is full-duplex, it can transmit and receive characters simultaneously. The software may use either polling or interrupts to operate the UART. Both transmission and reception are double buffered to relax software response time.

2.0 Architecture (Continued)

A transmit interrupt is generated on transmit ready, if not masked by the UMASK register. A receive interrupt is generated, if not masked by the UMASK register, on receive ready for every received character regardless of the occurrence of a reception error. A reception error has no effect on the current or the next data reception. i.e., the current data is available in the data buffer and the next data reception will occur in the usual way.

No reception is enabled during break on the UART Receive (URXD) pin. A high-to-low transition is, therefore, required to detect a start bit.

The UART data buffers are eight bits wide.

Whenever a new character is received, and the data buffer is empty, the data buffer and the status register are updated. Hardware flow control can be implemented either by software (using the Ports module) or by hardware. When controlled by hardware, transmission starts only if the Transmit Enable input pin (\overline{UTEN}) is asserted low. Once a byte transmission starts, the \overline{UTEN} value is ignored till the stop bit is transmitted.

The Receive Enable output pin (\overline{UREN}) is inactive (high) when both the receiver shifter and buffer are full. \overline{UREN} is asserted low when the buffer or the shifter is empty.

2.7.3 Registers

URXB: Reception data buffer. Read only. 8-bit register.
 Bit 0 is the first bit serially received.
 Bit 7 is cleared during reception of 7-bit characters.
 Reading URXB updates the UCLST.RF status bit.
 If a new character is ready in the shifter, the URXB is updated with the new value after the current value has been read.

UTXB: Transmission data buffer. 8-bit register.
 Bit 0 is the first bit serially transmitted.
 Bit 7 is ignored during transmission of 7-bit characters.

UBRGL: Low byte of the CTTL clock divider (UBRG). 8-bit register.

UBRGH: High byte of the CTTL clock divider (UBRG). 8-bit register.

These two, one-byte, registers are used to generate a clock, whose frequency is 16 times the baud rate, according to the following equation:
 $CTTL / (UBRG + 1) = \text{baud-rate} * 16$.

UCNTL: UART Control register.

Controls the number of data and stop bits, parity enable/disable and odd/even and break transmission on/off. Upon reset all the non reserved bits are cleared to "0".

UMASK: UART Mask Interrupts register. Upon reset, the implemented bits are cleared to "0".

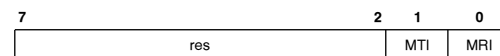

MTI: Mask Transmit Interrupt

- 0: Transmit Interrupt is not masked
- 1: Transmit Interrupt is masked

MRI: Mask Receive Interrupt

- 0: Receive Interrupt is not masked
- 1: Receive Interrupt is masked

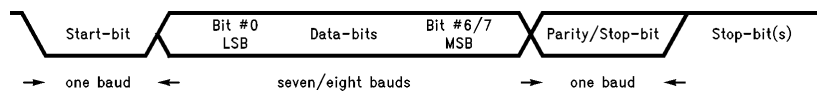

FIGURE 2-20. Character Format

TL/EE/11331-25

2.0 Architecture (Continued)

7	6	5	4	3	2	1	0
TBRK	res	res	res	TSB	EDB	PEN	EPS

- EPS:** Even Parity Select.
 0 : Odd parity
 1 : Even parity
 Even parity means that the total number of bits set (including the parity bit) is even.
- PEN:** Parity Enable.
 0 : Parity disabled
 1 : Parity enabled
- EDB:** Number of data bits.
 0 : Seven data bits
 1 : Eight data bits
- TSB:** Number of stop bits transmitted.
 0 : One stop bit
 1 : Two stop bits
- TBRK:** Transmission Break Control—implemented by forcing UTXD pin low.
 0 : No break signal
 1 : Break signal
 Undefined results when TBRK is “1” while UCLST.TE is “0”.
- UCLST:** UART Clearing Status register. 8-bit register.

7	6	5	4	3	2	1	0
TR	TE	res	OE	res	FE	PE	RF

- Receive status bits: Upon reset, these status bits are cleared to “0”.
- RF:** Receive Full. RF = 1 when URXB is loaded by the shift register.
- PE:** Parity Error. PE = 1 when parity error is detected.
- FE:** Frame Error. FE = 1 when the first stop bit is “0”.
- OE:** Overrun Error. OE = 1 when both reception buffer and shifter are full and a new character is received.
- Transmit status bits: Upon reset, these status bits are set to “1”.
- TE:** Transmit Empty. TE = 1 when both UTXB and the shifter are empty.
- TR:** Transmit Ready. TR = 1 when UTXB is empty.
- OE status bit is sticky. Once set, it is cleared by reset or by writing into UCLST (data written into this register is ignored). RF is cleared during reset. It is set to “1” when URXB is loaded by the shift register. It is updated by a URXB read: RF remains “1” if the shifter already holds a new character, and is cleared to “0” if the shifter did not finish reception of a new character.
- PE and FE bits are sticky. These two bits are cleared during reset and whenever UCLST is read.

2.7.4 Usage Recommendations

- Before activating the UART, program the appropriate Ports module registers PADI, PAMS, PBDO, PBMS, PCDO, PCMS and PCEN to connect the UART module to the NS32FX100 I/O pins.
- Initialization:
 - Disable interrupts or mask the UART interrupt.
 - Initialize UBRG and then UCNTL.
 - Clear receiver status bits using URXB and UCLST.
 - Enable UART interrupt, if required.
 - Program the PAMS register in the Ports module as follows:
 - MS0 must be cleared before data is transmitted from the UART.
 - MS1 must be set before data can be received on the URXT pin.
- To use the PE and FE status bits as non-sticky bits, read the UCLST before reading URXB. Note that right after URXB is read, it might be loaded with a new character which was waiting in the shifter, and those status bits might be set by the new URXB. Therefore, it is recommended to read UCLST first and then read URXB, thus keeping coherence between the contents of URXB and UCLST.
- When \overline{UTEN} is inactive, the TE bit does not ensure that two characters may be written to the UTXB. The TR bit must be “0” before each UTXB write.

2.8 MICROWIRE (MWIRE)

2.8.1 Features

- Operates as a MICROWIRE master
- Programmable shift-clock frequency
- 8-bit serial I/O data shift register
- Busy flag for polling and as an interrupt source
- Two modes of clocking data

2.8.2 Operation

The MICROWIRE (MWIRE) is a serial synchronous communication interface. It enables an interface with any National Semiconductor chip that supports MICROWIRE protocol, such as COPs and EEPROMs. The MWIRE interface consists of three signals: serial data in, serial data out, and serial clock. Several devices may share the same MWIRE channel by means of device-select signals. Such select signals may be provided by the Ports module. The MWIRE outputs may be TRI-STATED by the Ports module. A high level interrupt is generated when the MWIRE is not busy, and is cleared only while MWIRE is busy. The serial data is sampled on the serial clock falling edge. The serial data out may change on the serial clock rising or falling edge, according to the software selected mode.

2.8.3 Registers

- MWSIO:** MICROWIRE Serial I/O Shift register. 8-bit shift register.
 Used for data transfer over the MWIRE channel. Bit-7, the most significant bit, is transmitted first.

2.0 Architecture (Continued)

Accessing MWSIO while the MWIRE is busy (MWCSR.BUSY = 1) may cause unpredictable results.

MWCSR: MICROWIRE Control and Status register.

7	5	4	3	1	0
res	CLKM	CDV		BUSY	

BUSY: Read only. Set to "1" during MWIRE transaction. Cleared to "0" on termination. Used also as the MICROWIRE interrupt source.

CDV: Clock Divider.
Divides the MCLK clock by 2^{*n} , where $n = [0..5]$, to generate the MWIRE shift clock.

000 : Non divided MCLK

001 : MCLK/2

010 : MCLK/4

011 : MCLK/8

100 : MCLK/16

101 : MCLK/32

Other : Reserved

CLKM: Clocking mode:

0 : MWSO changed on MWSK rising edge.
MWSK clock is high when MWIRE is idle.

1 : MWSO changed on MWSK falling edge.
MWSK clock is low when MWIRE is idle.

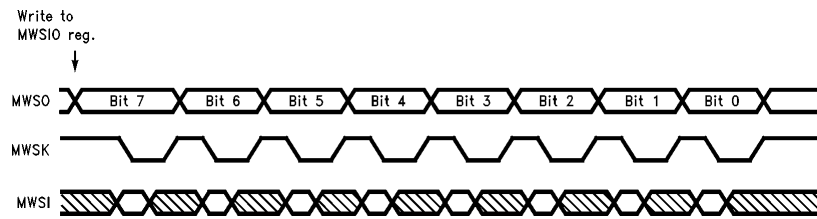

FIGURE 2-21. MICROWIRE Transaction (CLKM = 0)

TL/EE/11331-26

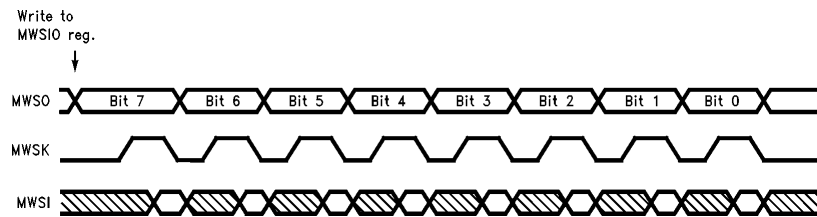

FIGURE 2-22. MICROWIRE Transaction (CLKM = 1)

TL/EE/11331-27

2.0 Architecture (Continued)

2.8.4 Usage Recommendations

1. Before activating the MICROWIRE, program the appropriate Ports module registers PBDO, PBMS, PCDO, PCMS and PCEN to connect the MICROWIRE module to the NS32FX100 I/O pins.
2. The correct sequence for a MWIRE transaction is to select a device, issue the MWIRE transaction, and then de-select the device. A device can be selected either by using the Ports module, or implicitly if only one device is connected to the bus).
3. Writing to MWSIO register triggers the shift transaction. Reading the MWSIO does not trigger a shift transaction but returns the current contents of the MWSIO. For a read transaction, perform a dummy write transaction to initiate the shift and then read the MWSIO, i.e., write a byte, wait until not busy and then read the result.

2.9 INTERRUPT CONTROL UNIT (ICU)

2.9.1 Features

- 16 interrupt sources
- Supports CPU vectored-interrupt mode
- Fixed priority among interrupt sources
- Individual enable/disable of each interrupt source
- Polling support by an interrupt pending register
- Programmable triggering mode and polarity

2.9.2 Operation

The Interrupt Control Unit (ICU) receives interrupt signals from internal and external sources and generates a vector interrupt to the CPU when required. Priority among the interrupt sources is fixed. Each interrupt source can be individually enabled or disabled. Pending interrupts can be polled using the interrupt pending register, regardless of their being enabled or disabled.

The ICU triggering mode and polarity of each interrupt source (individually) are both programmed via the Interrupt Edge/Level Trigger register (IELTG) and the Interrupt Trigger Polarity register (ITRPL). Both the polarity and the triggering mode of the interrupts that are generated on-chip are fixed. It is the software's responsibility to program the respective bits in IELTG and ITRPL as required.

Edge-triggered interrupts are latched by the interrupt pending register. A pending edge-triggered interrupt is cleared by writing the required value to the edge interrupt clear register. A pending level-triggered interrupt is cleared only when the interrupt source is not active.

Interrupt vector numbers are always positive, in the range 20(hex) to 2F(hex).

MCFG.ESCAN bit controls the IRQ11 interrupt source. MCFG.EDMA0 bit controls the IRQ13 interrupt source. TPHC.PIS bit controls the IRQ14 interrupt source.

The external interrupt inputs are asynchronous. They are recognized by the NS32FX100 during cycles in which the input setup and hold time requirements are satisfied.

TABLE 2-3. Interrupt Sources and Priority Levels

IRQ0	Internal	Level-High	MICROWIRE	Lowest Priority
IRQ1	External		INT0 Pin	
IRQ2	Internal	Edge-Rising	System Tick	
IRQ3	Internal	Edge-Rising	TIMER Pulse	
IRQ4	External		INT1 Pin	
IRQ5	Internal	Level-High	UART	
IRQ6	Internal	Level-High	SDC Transmit	
IRQ7	Internal	Level-High	SDC Receive	
IRQ8	Internal	Level-High	SDC Error	
IRQ9	External		INT2 Pin	
IRQ10	Internal	Edge-Rising	Printer Motor	
IRQ11	Internal	Edge-Rising	Scanner Motor or DMA Channel 2 (Selected by MCFG)	
IRQ12	Internal	Edge-Rising	DMA Channel 3	
IRQ13	Internal	Edge-Rising	Scanner or DMA Channel 0 (Selected by MCFG)	
IRQ14	Internal	Edge-Rising	Printer or DMA Channel 1 (Selected by TPHC)	
IRQ15	External		INT3 Pin	Highest Priority

2.0 Architecture (Continued)

2.9.3 Registers

IVCT: Interrupt Vector register. Read only. 8-bit register.

7	6	5	4	3	2	1	0
0	0	1	0	INTVECT			

INTVECT: When $\overline{\text{INTR}}$ pin is active, this field contains the encoded value of the enabled pending interrupt that has the highest priority.

IENAM: Interrupt Enable And Mask register. 16-bit register.

Enables each interrupt individually.

The bits of IENAM correspond to interrupts 0–15. Each bit is encoded as follows:

- 0: Interrupt is disabled.
- 1: Interrupt is enabled.

IPEND: Interrupt Pending register. Read only. 16-bit register.

Indicates which interrupts are pending. Bits 0–15 of IPND correspond to interrupts 0–15. Each bit is encoded as follows:

- 0: Interrupt is not pending.
- 1: Interrupt is pending.

IECLR: Edge Interrupt Clear register. Write only. 16-bit register.

Used to clear pending, edge-triggered, interrupts. Writing to the bit positions of level-triggered interrupts has no effect. The bits of IECLR correspond to interrupts 0–15. Each bit is encoded as follows:

- 0: No effect.
- 1: Clear the pending interrupt.

IELTG: Edge/Level Trigger. 16-bit register.

Each bit defines the way that the corresponding interrupt request is triggered, either edge-sensitive or level-sensitive.

Each IELTG bit is encoded as follows:

- 0: Level-sensitive.
- 1: Edge-sensitive.

For normal invocation of internal interrupt sources, bits 0, 5, 6, 7 and 8 must be “0”; bits 2, 3, 10, 11, 12, 13 and 14 must be “1”.

ITRPL: Trigger Polarity. ITRPL is a 16-bit register that controls the triggering polarity. ITRPL bits are encoded as follows:

Level-sensitive trigger type:

- 0: Low level.
- 1: High level.

Edge-sensitive trigger type:

- 0: Falling edge.
- 1: Rising edge.

For normal invocation of internal interrupt sources, bits 0, 2, 3, 5, 6, 7, 8, 10, 11, 12, 13 and 14 must be “1”.

Program the IELTG and ITRPL registers, to control the ICU mode and polarity, as follows:

IELTG	ITRPL	Mode
0	0	Low Level
0	1	High Level
1	0	Falling Edge
1	1	Rising Edge

2.9.4 Usage Recommendations

1. Initialization:

The recommended initialization sequence is:

- a. Initialize the INTBASE register of the CPU
- b. Program the interrupts’ triggering mode and polarity
- c. Prepare the interrupt routines of the used interrupts
- d. Clear the used edge-interrupt
- e. Set the relevant bits of IENAM
- f. Enable the CPU interrupt (via the PSR register of the CPU)

2. Clearing:

Clearing an interrupt request before it is serviced may cause a spurious interrupt, (i.e., the CPU detects an interrupt not reflected by IVCT). The user is advised to clear interrupt requests only when interrupts are disabled.

Changing triggering mode or polarity may also cause a spurious interrupt and should thus be carried out only when the interrupts are disabled.

Clearing any of the IENAM bits should be carried out while the I bit in the PSR register of the CPU is cleared.

3. Nesting:

There is no hardware limitation on nesting of interrupts. Interrupts’ nesting is controlled by writing into the Enable And Mask register (IENAM). When the CPU acknowledges an interrupt, the CPU’s PSR.I bit is cleared to “0”, thus disabling interrupts. While an interrupt is in service, the user may allow other interrupts to occur by updating IENAM, then setting PSR.I bit to “1”. The IENAM register can be used to control which of the other interrupts is enabled.

2.10 PORTS MODULE

2.10.1 Features

- Individual or group enable/set/clear of any output port
- Read latched state of input ports
- Some Port I/O pins can be allocated to other modules
- External extension output port support

2.10.2 Operation

This module includes three types of ports:

- General-purpose input/output ports.
- External output port extension.
- Stepper-motors output ports.

2.10.2.1 General Purpose Input/Output Ports

These ports enable access to individual, general-purpose, input/output pins. There are three general purpose ports. Port A provides four input pins, Port B provides 12 output pins, Port C provides eight I/O pins. Some pins are shared

2.0 Architecture (Continued)

with other modules, and are allocated by software. Input pins can always be read, even if shared with another module. Output pins can be enabled or disabled (TRI-STATE).

The characteristics of the four bits which may be associated with the ports are as follows:

- DI: Data In bit. Read only. Holds current value/state of the pin.
- DO: Data Out bit. Write/read. Holds the value to be driven onto the pin when the respective MS bit is "0". When read back, DO is not effected by the MS bit.

- EN: Enable bit. Write/read. TRI-STATE when EN = 0, drive when EN = 1.

- MS: Module Select bit. Write/read. Selects output pin source and input pin destination.

When MS = 0, pin is connected to the port.

When MS = 1, pin is connected to the module that shares this pin.

When an input signal is assigned to a module (by setting the respective MS bit to "1"), the associated EN bit must be cleared to "0".

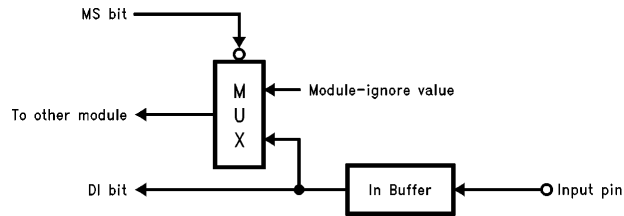

FIGURE 2-23. Port A

TL/EE/11331-28

Two bits are associated with each input pin of this port:

DI: Data In Bit

MS: Module Select Bit

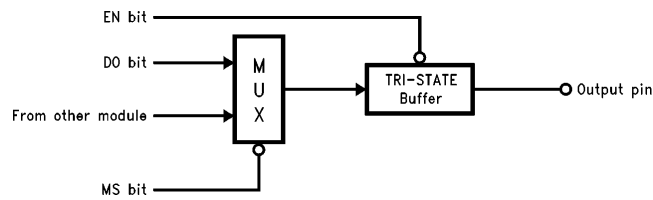

FIGURE 2-24. Port B

TL/EE/11331-29

Three bits are associated with each output pin of this port:

DO: Data Out Bit

EN: Enable Bit

MS: Module Select Bit

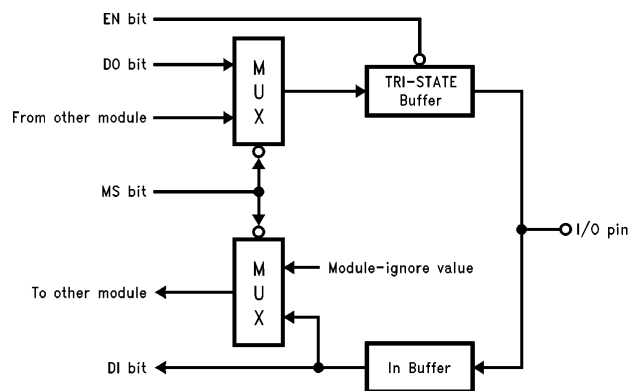

FIGURE 2-25. Port C

TL/EE/11331-30

2.0 Architecture (Continued)

Four bits are associated with each general purpose I/O pin of this port:

- DI: Data In Bit
- DO: Data Out Bit
- EN: Enable Bit
- MS: Module Select Bit

Port input data is asynchronous. When the input is read while it is changing, the value read is unreliable. The software should read an input either when it is guaranteed that the input is stable, or perform debouncing. If the input satisfies the required set-up and hold times, the value read is the true input value. With the exception of URXD and UTEN, when an input is assigned to a module it must satisfy the required set-up and hold times. The results are unpredictable if this requirement is not satisfied.

2.10.2.2 External Output Port Extension

The number of output ports of an NS32FX100-based FAX system can be expanded by an external latch, such as the DM74LS373 chip. Two such latches can add 16 output pins without any additional glue logic. This module controls such an external latch.

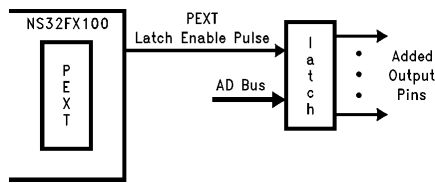

TL/EE/11331-31

FIGURE 2-26. External Output Port Extension

The latch data inputs are taken from the system data bus. The latching signal is generated by the NS32FX100. The NS32FX100 includes the PEXT register, which is an on-chip mirror register of the external latch. This is used to ease the setting, or clearing, of individual bits by enabling the CPU to read back the port value, modify the required bit(s) and write the new value to the external latch. The read back is performed from PEXT rather than from the write-only external latch. Writing is performed simultaneously to both the external latch and to PEXT. The external latching signal is generated when PEXT is being written into, i.e., at T3 of the write transaction. It is also active during reset to enable initialization of the external output port extension.

2.10.2.3 Stepper Motors Output Ports

The stepper motor is controlled by four phases. The phases values are stored by software into the Ports module registers and are transferred into the phase pins by the motor interrupt pulse rising edge.

2.10.3 Registers

PADI: Port A data in. Read only.

Each bit holds the current value of the corresponding input pin.

7	4	3	2	1	0
res			DMRQ3	MWSI	URXD
					UTEN

PAMS: Port A module select.

7	2	1	0
res		MS1	MS0

MS0, MS1: Module select bits for Port A input pins.

The UART's UTEN input is forced low when MS0 = 0.

The UART's URXD input is forced high when MS1 = 0.

res: Reserved

MS0 must be cleared before data is transmitted from the UART.

MS1 must be set before data can be received on the URXD pin.

Upon reset this register is cleared to "0".

PBDO: Port B data out.

Each bit holds the value driven onto the corresponding output pin when the respective MS bit, in the PBMS register, is "0".

7	6	5	4	3	2	1	0
DMARK3	SDIS/DMARK2	DMARK1	SCLK2/DMARK0	STB3	STB2	STB1	STB0
15				12	11	10	9
res				SLS	SCLK1	SPDW	MSWK

PBMS: Port B module select.

15	12	11	10	9	8	7	6	5	4	3	2	1	0
res	MS11	MS10	MS9	MS8	MS7	MS6	MS5	MS4	MS3	MS2	MS1	MS0	

MS0-MS11: Module select bits for Port B output pins.

0: Port is selected.

The value of the corresponding bit in the PBDO register is driven on the respective pin, when Port B is enabled through the PBEM register.

1: Module is selected.

The value of the pin specified by the corresponding bit in the PBDO register is driven from the appropriate module: Printer, Scanner, DMA.

Upon reset this register is cleared to "0".

When the Scanner or the DMA module is activated through the MCFG register, MS4 and MS6 must be set to "1" as detailed in the following table:

Module	MCFG.EDMA0	MS4	Module	MCFG.ESCAN	MS6
DMA	0	1	DMA	0	1
Scanner	1	1	Scanner	1	1
Port	X	0	Port	X	0

PBEN: Port B enable.

15	1	0
res		EN

EN: Controls the pins' state. All pins are driven when this bit is set. Upon reset bit 0 is cleared, causing the output pins to be in TRI-STATE.

2.0 Architecture (Continued)

PCDI: Port C data in. Read only.

Holds the current value of the pins (latched once each CCTL).

7	6	5	4	3	2	1	0
UREN	UTXD	MWSO	SBPYS/ DMRQ2	PCLK/ DMRQ1	SNH/ DMRQ0	PIO1	PIO0

PCDO: Port C data out.

Each bit holds the value driven onto the corresponding output pin when the respective MS bit, in the PCMS, register is "0".

7	6	5	4	3	2	1	0
UREN	UTXD	MWSO	SBPYS/ DMRQ2	PCLK/ DMRQ1	SNH/ DMRQ0	PIO1	PIO0

PCMS: Port C module select.

7	6	5	4	3	2	1	0
MS7	MS6	MS5	MS4	MS3	MS2	res	

MS2–MS7: The module select bits for port C I/O pins.

0: Port is selected.

The value of the corresponding bit in the PCDO register is driven on the respective pin, when Port C is enabled through the PCEN register.

1: Module is selected.

The value of the pin specified by the corresponding bit in the PCDO register is driven to/ from the appropriate module: Printer, Scanner, DMA.

Upon reset this register is cleared to "0".

When the Scanner, Printer or DMA module is activated through the MCFG register, MS2, MS3 and MS4 must be set to "1" as detailed in the following table.

Module	MCFG.EDMA0	MS2	Module	MCFG.EPBMS	MS3	Module	MCFG.ESCAN	MS4
DMA	0	1	DMA	0	1	DMA	0	1
Scanner	1	1	Printer	1	1	Scanner	1	1
Port	X	0	Port	X	0	Port	X	0

2.0 Architecture (Continued)

PCEN: Port C Enable.

7	6	5	4	3	2	1	0
EN7	EN6	EN5	EN4	EN3	EN2	EN1	EN0

EN0–EN7: Enable bit for Port C output pins.

A pin is driven when its relevant EN_i bit is set to “1”, or not driven (TRI-STATE) when its relevant EN_i bit is cleared to “0”.

The inputs are readable regardless of the state of the respective EN_i bit. Upon reset PCEN is cleared to “0”.

PEXT: External output port mirror register. 16-bit register. When this register is read, no external latch pulse is generated.

When this register is written, an external latch pulse is generated to enable simultaneous write into both this register and the external latch.

PMPH: Printer Motor Phase Register. 8-bit register.

The register holds the value to be driven by the PMPH0–3 pins on the next printer motor interrupt rising edge. Bits 0–3 control the four phases. Bits 4–7 are reserved.

A double buffer is used to latch the next values and to drive the pins. The PMPH0–3 pins are always driving.

Upon reset the pins are driven low.

SMPH: Scanner Motor Phase register. 8-bit register.

The register holds the value to be driven by the SMPH0–3 pins on the next scanner motor interrupt rising edge. Bits 0–3 control the four phases. Bits 4–7 are reserved.

A double buffer is used to latch the next values and to drive the pins. The SMPH0–3 pins are always driving.

Upon reset the pins are driven low.

2.10.4 Usage Recommendations

When working with the Printer Bitmap Shifter, using DMA channel 1 to load the shifter, the PBMS.MS5 bit must be cleared to “0” (PBMS.MS5 = 0).

2.11 BUS AND MEMORY CONTROLLER (BMC)

2.11.1 Features

- Direct interface to the CPU bus
- Direct interface with ROM, SRAM and I/O devices
- Programmable wait-state generator
- Supports both 8-bit and 16-bit access requests
- Direct interface with DRAM (NS32FX200 and NS32FV100 only).
- $\overline{\text{CAS}}$ before $\overline{\text{RAS}}$, DRAM refresh (NS32FX200 and NS32FV100 only)

2.11.2 Operation

The Bus and Memory Controller (BMC) directly interfaces to the CPU. It responds to read and write transactions and generates DMA transactions. The memory controller directly interfaces to ROM, SRAM and I/O devices. The NS32FX200 and NS32FV100 also support DRAM devices. It generates the required memory control and CPU wait signals.

The BMC decodes the high-order address bits and distinguishes between five zones, one zone for access to the NS32FX100 on-chip memory-mapped registers and four external zones. The wait-state generator inserts a programmable number of wait-states according to the accessed address zone.

Address decoding (Hex):

Address: 000000–3FFFFFFF (4 Mbyte):	Configurable Zone #0—ROM or Zone #2—DRAM. (NS32FX100 always: Zone #0—ROM)
Address: 400000–7FFFFFFF (4 Mbyte):	Zone #2—DRAM. (NS32FX100—Reserved)
Address: 800000–BFFFFFFF (4 Mbyte):	Zone #0—ROM.
Address: C00000–DFFFFFFF (2 Mbyte):	Zone #1—SRAM.
Address: E00000–EFFFFFFF (1 Mbyte):	Zone #3—I/O.
Address: F00000–FFFFFFF (1 Mbyte):	NS32FX100 registers.

Memory is 16-bit (word)-wide. A system, heavily loaded with memory and I/O devices, needs address buffers. If required, additional wait states can be added during access to the buffered devices by programming the appropriate register.

After reset, the first instruction fetch is from address 0, located in Zone 0—ROM Zone. If a RAM is required in the lower address space, the boot program should jump to the upper Zone 0 address space and only then configure the RAM in the low address space.

In Power Save mode (low running frequency) all memory transactions are performed as no-wait transactions, regardless of the values specified in the Memory Wait State (MWAIT) register. Memory transactions issued by the CPU and by the NS32FX100 DMA controller are almost identical. An NS32FX100 DMA transaction is performed after the $\overline{\text{HOLD}}$ request issued by the NS32FX100 is acknowledged by the CPU. Memory signals are driven by the NS32FX100. They are driven in the same manner for both CPU transactions and NS32FX100 DMA transactions.

1. The CPU drives AD0–AD15 throughout T4 whereas the NS32FX100 does not drive AD0–AD15 to the end of T4, thus minimizing potential contention on the AD0–AD15 bus.
2. The NS32FX100 does not drive $\overline{\text{HBE}}$ and address on AD0–AD15 during T1.
3. The CPU drives $\overline{\text{ADS}}$ in T1 for half a cycle whereas the NS32FX100 drives $\overline{\text{ADS}}$ from T_i to T1 for one cycle.

The memory device does not need to distinguish between the two types of transactions, as both are identical for the memory device. Read transactions are always word-wide. Write transactions are either byte-wide or word-wide. $\overline{\text{WE0}}$ controls writing to even bytes and $\overline{\text{WE1}}$ controls writing to odd bytes.

2.0 Architecture (Continued)

Memory transactions are either adjacent (back-to-back) or spaced with idle cycles. To increase pre-charge time, and to avoid contention on the AD0–AD15 bus, the memory transactions may be spaced by idle cycles. When an IDLEi field of the Memory Wait-state Control (MWAIT) register is set, the NS32FX100 asserts the $\overline{\text{HOLD}}$ signal to force two idle cycles (Figure 51).

2.11.2.1 Zones 0, 1 (ROM and SRAM) Transactions

Zone 0 memories are selected by the $\overline{\text{SEL0}}$ output pin. Zone 1 memories are selected by the $\overline{\text{SEL1}}$ output pin. External logic may be used to sub-divide a zone into banks if required. In this case the external logic can add wait states for a bank by manipulating the wait signal externally.

A basic transaction starts in T1, when A16–A23, driven by either the CPU or the NS32FX100, are valid. Then MA1–MA15, driven by the NS32FX100, are valid in T1. Either $\overline{\text{SEL0}}$ or $\overline{\text{SEL1}}$ is asserted low by the NS32FX100 in T1. MA1–MA15 hold address bits 1–15. The transaction may be extended by wait states, denoted by T3W. The relevant WAITi field of the MWAIT register controls the number of T3W cycles. On a read transaction $\overline{\text{OE}}$ is asserted low in T2 and de-asserted in T4. During a read transaction $\overline{\text{WE0}}$ and $\overline{\text{WE1}}$ are inactive. During a write transaction an even byte is written when $\overline{\text{WE0}}$ is asserted low, an odd byte is written when $\overline{\text{WE1}}$ is asserted low and a word is written when both $\overline{\text{WE0}}$ and $\overline{\text{WE1}}$ are asserted low. The write-enable signal(s) is asserted low in T2 and de-asserted in T3 (or last T3W if the transaction is extended by wait states). During write transactions $\overline{\text{OE}}$ is inactive.

2.11.2.2 Zone 2 (Dynamic Memory) Transactions (NS32FX200 and NS32FV100 only)

For the NS32FX100, Zone 2 is reserved.

There are two non-interleaved memory banks in this zone. Access to the first bank is controlled by the $\overline{\text{RAS0}}$ signal. Access to the second bank is controlled by the $\overline{\text{RAS1}}$ signal. The size of the banks is configured by the DRAM Page Size

(DPS) field of the BMC Configuration Register (BMCFG). (The terms DRAM “page size” and “column size” are interchangeable.) The second bank is adjacent to the first bank.

Three basic DRAM cycles are supported: read cycle, early write cycle and $\overline{\text{CAS}}$ before $\overline{\text{RAS}}$ refresh cycle. During read or early write transactions, only one bank is selected—either $\overline{\text{RAS0}}$ or $\overline{\text{RAS1}}$ is active. During refresh transactions, both $\overline{\text{RAS0}}$ and $\overline{\text{RAS1}}$ are active.

The Timing Control Unit (TCU) issues refresh requests, if configured to do so by the TCU’s Refresh Enable register (RFEN).

Arbitration between refresh transactions and CPU/DMA transactions: If a refresh access is in progress, the CPU or DMA access will be postponed. If a CPU or DMA access is in progress, the refresh will be postponed.

If refresh is requested in T1 of CPU/DMA access, the refresh will be served first. On Zone 0 and Zone 1 access, $\overline{\text{SEL0}}$ or $\overline{\text{SEL1}}$ is active during T1 and T2 of the refresh (see Figure 3-11). In any case, neither $\overline{\text{OE}}$ nor $\overline{\text{WEi}}$ are active during the refresh.

The BMC module generates refresh transactions during both Normal and Power Save modes but not during reset or freeze mode. However, a refresh transaction, already in progress, is completed even if reset or power-down is activated. A freeze transaction is generated by the TCU module during reset and freeze mode, if configured to do so. This Freeze mode refresh transaction is also a $\overline{\text{CAS}}$ before $\overline{\text{RAS}}$ transaction although its timing is different from that of the normal refresh transaction. The Freeze mode refresh transaction is described in the Timing Control Unit section.

A basic DRAM transaction starts with row-address valid on MA1–MA11 in T1. Either $\overline{\text{RAS0}}$ or $\overline{\text{RAS1}}$ is asserted low in T2, and the memory devices latch the row address, then a valid column address is driven onto MA1–MA11 in T2. The row and column address is multiplexed as follows:

TABLE 2-4. DRAM Address Multiplexing

Multiplexed Address	Row Address	Column Address			
		DPS = 00*	DPS = 01*	DPS = 10*	DPS = 11*
MA1	A1	A9	A10	A11	A12
MA2	A2	A10	A11	A12	A13
MA3	A3	A11	A12	A13	A14
MA4	A4	A12	A13	A14	A15
MA5	A5	A13	A14	A15	A16
MA6	A6	A14	A15	A16	A17
MA7	A7	A15	A16	A17	A18
MA8	A8	A16	A17	A18	A19
MA9	A9	A17	A18	A19	A20
MA10	A10	A18	A19	A20	A21
MA11	A11	A19	A20	A21	A22

*DPS—DRAM Page Size control field in the BMCFG register.

TABLE 2-5. DRAM Address Sizes

DPS	Banksize	Examples for DRAM Types
00	128 kbyte	(64k x 4-bit) x 4/(64k x 4-bit) x 8
01	512 kbyte	(256k x 4-bit) x 4/(256k x 4-bit) x 8
10	2 Mbyte	(1M x 4-bit) x 4/(64k x 4-bit) x 8
11	8 Mbyte	(4M x 4-bit) x 4

2.0 Architecture (Continued)

As in other memory transactions, address bits A12–A15 are driven onto MA12–MA15 in T1 (non-multiplexed). \overline{CAS} is asserted low in T3. Once \overline{CAS} is asserted, the transaction may be extended by wait states, denoted by T3W. The WAIT2 field of the MWAIT register controls the number of T3W cycles. \overline{CAS} is asserted low during T3 and T3W. \overline{CAS} and $\overline{RAS0}$ or $\overline{RAS1}$ are de-asserted in T4. During read transactions $\overline{WE0}$ and $\overline{WE1}$ are inactive. \overline{OE} is asserted low and a word is read from memory. During write transactions \overline{OE} is inactive. An even byte is written when $\overline{WE0}$ is asserted low. An odd byte is written when $\overline{WE1}$ is asserted low. A word is written when both $\overline{WE0}$ and $\overline{WE1}$ are asserted low. On a read transaction \overline{OE} is asserted low in T2 and de-asserted in T4. The write-enable signal(s) is asserted low in T2 and de-asserted in T3 (or last T3W if the transaction is extended by wait states). A normal DRAM refresh transaction starts with one idle cycle, denoted T1. During the next cycle, T2, \overline{CAS} is asserted low. One cycle later, at T3, $\overline{RAS0}$ and $\overline{RAS1}$ are asserted low. The refresh transaction may be extended by $3 \times T3W$ cycles, according to the WAITR field of the MWAIT register. \overline{CAS} , $\overline{RAS0}$ and $\overline{RAS1}$ are de-asserted from T4 through T5.

Some DRAM devices require an initial “refresh only” period, to charge their voltage pumps, after the power is turned on. Since these DRAMs should not be accessed during this period, it is the software’s responsibility to ensure that the initialization routine addresses only ROMs until this period has expired. The DRAM must not be accessed, by software, for 16 slow-clock cycles after reset to ensure clean switching to the refresh control for the Power Save/Normal mode.

2.11.2.3 Zone 3 (I/O) Transactions

Zone 3 provides extended set-up and hold times. It also provides more wait states than Zones 0, 1 and 2. The actual access is extended by four cycles in write and by two cycles in read. More wait cycles may be programmed, in steps of two, by the WAIT3 field of the MWAIT register.

A basic transaction starts in T1, when A16–A23, driven by either the CPU or the NS32FX100, are valid. Then MA1–MA15, driven by the NS32FX100, are valid in T1. $\overline{SEL3}$ is asserted low by the NS32FX100 in T3.

During a read transaction \overline{OE} is asserted low on the second T3W. Once \overline{OE} is asserted, the transaction may be extended, according to WAIT3 field of MWAIT register, by wait states denoted by T3W. \overline{OE} is de-asserted in T4, $\overline{SEL3}$ is de-asserted two cycles after \overline{OE} is de-asserted and MA1–MA15 are driven for one more cycle. The NS32FX100 extends the transaction beyond T4 of the CPU, \overline{HOLD} is asserted from T2 till T4. A16–A23 are not valid after T4 of the CPU. If address hold time is required by the memory (or memory mapped I/O), only MA1–MA15 should be used. $\overline{WE0}$ and $\overline{WE1}$ are inactive during read transactions. The minimum number of waits, for a read transaction, is two.

During a write transaction, an even byte is written when $\overline{WE0}$ is asserted low, an odd byte is written when $\overline{WE1}$ is asserted low and a word is written when both $\overline{WE0}$ and $\overline{WE1}$ are asserted low. The write enable signal(s) is asserted low on the second T3W. Once the write enable signal(s) is asserted, the transaction may be extended, according to the WAIT3 field of the MWAIT register, by wait states denoted by T3W. The write enable signal(s) is de-asserted one cycle before the last T3W. $\overline{SEL3}$ is deasserted in T4. MA1–MA15 are driven for one more cycle. \overline{OE} is inactive during write transactions. The minimum number of waits, for a write transaction, is four.

2.11.2.4 Operation in Freeze Mode

In freeze mode, all output signals except MA1–MA15, \overline{CAS} , $\overline{RAS0}$, $\overline{RAS1}$, SDOOUT, SDFDBK, CCLK, FOSCO and SOSCO are in TRI-STATE. MA1–MA15 are driven low, and if less than 0.1 mA is driven, their voltage is below GND + 0.2V. \overline{OE} , $\overline{SEL1}$, $\overline{WE0}$ and $\overline{WE1}$ are driven high, and if less than 0.1 mA is driven, their voltage is above $V_{CCD}-0.2V$. $\overline{SEL0}$ and $\overline{SEL3}$ are driven high. When the ETC count reaches zero in S4 (Freeze and Refresh state) the state machine reaches S5, refresh transactions are stopped and \overline{CAS} , $\overline{RAS0}$ and $\overline{RAS1}$ are driven low. If refresh is enabled, these three control signals are driven low during state S5 of the Power Save mode, and, if less than 0.1 mA is driven, their voltage is below GND + 0.2V.

2.11.2.5 On-Chip Registers Access

Access to the on-chip registers is a zero-wait transaction.

2.11.3 Registers

BMCFG: BMC Configuration Register.

7	3	2	1	0
res	DRA0	DPS		

- DPS: DRAM page size. Selects the DRAM column size.
- 00 : Column size = 256 bytes; \overline{RASi} controlled by A17.
For DRAM with 8 muxed address bits; Bank size = 128 kbyte.
 - 01 : Column size = 512 bytes; \overline{RASi} controlled by A19.
For DRAM with 9 muxed address bits; Bank size = 512 kbyte.
 - 10 : Column size = 1024 bytes; \overline{RASi} controlled by A21.
For DRAM with 10 muxed address bits; Bank size = 2 Mbyte.
 - 11 : Column size = 2048 bytes; only $\overline{RAS0}$ —no $\overline{RAS1}$.
For DRAM with 11 muxed address bits; one bank of 8 Mbyte.
- DRA0: DRAM At 0—Controls the assignment of low 4 Mbyte addresses.
- 0 : Zone #0—ROM
 - 1 : Zone #2—DRAM

When DPS = 11 and DRA0 = 0, the lower half of the DRAM bank is not accessible. Upon reset the implemented bits are cleared to “0”.

MWAIT: Memory Wait State Register.

15	14	12	11	10	8	7	6	4	3	2	0
WAITR	WAIT3	IDLE2	WAIT2	IDLE1	WAIT1	IDLE0	WAIT0				

- WAIT0: Zone #0—ROM wait state control. See WAITi below.
- IDLE0: Zone #0—ROM idle control. See IDLEi below.
- WAIT1: Zone #1—SRAM wait state control. See WAITi below.

2.0 Architecture (Continued)

IDLE1: Zone #1—SRAM idle control. See IDLEi below.

WAIT2: Zone #2—DRAM wait state control. See WAITi below.

IDLE2: Zone #2—DRAM idle control. See IDLEi below.

WAITi: Number of T3W (wait) extension cycles ($i = 0, 1, 2$)

000 : Seven wait states.	100 : Three wait states.
001 : Six wait states.	101 : Two wait states.
010 : Five wait states.	110 : One wait states.
011 : Four wait states.	111 : Zero wait states.

IDLEi: ($i = 0, 1, 2$)

0 : No idle cycles after the respective transaction.

1 : Forces two idle cycles after the respective transaction.

WAIT3: Zone #3—I/O wait state control.

000 : Sixteen read waits, eighteen write waits.

001 : Fourteen read waits, sixteen write waits.

010 : Twelve read waits, fourteen write waits.

011 : Ten read waits, twelve write waits.

100 : Eight read waits, ten write waits.

101 : Six read waits, eight write waits.

110 : Four read waits, six write waits.

111 : Two read waits, four write waits.

WAITR: Wait states for DRAM refresh transaction

0 : Three wait states.

1 : Zero wait states.

Upon reset MWAIT is cleared to "0".

2.11.4 Usage Recommendations

Before accessing the DRAM for the first time:

- Initialize the Refresh Rate Control (RFRT) register in the TCU.
- Set Refresh Enabled (RFEN) on.
- Initialize BMCFG.
- Initialize MWAIT.
- Ensure that you provide an appropriate delay time for components which require a delay between power-up and the first DRAM access.

2.12 REGISTER SUMMARY

2.12.1 NS32FX100 Registers Access Method

Registers' address and access are listed in Section 2.12.2.

A byte transaction must be issued to access a byte register.

A word-aligned transaction must be issued to access a double-word register.

Unless otherwise specified, all registers are readable and writable.

Unless otherwise specified, all contents of the registers are undefined after reset.

Unpredictable results may occur when:

- Registers are not accessed according to the above rules.
- Access is made to other locations within the NS32FX100 address space.

Note: Some instructions, like SBITW and CBITW, issue byte transactions. Take care not to use these instructions if they are likely to cause transactions that violate the rules specified in this section. When a register includes a reserved bit (indicated by "res" field), it must be written as 0, and its value is undefined when read. Bit 6 of MCFG (marked as reserved) should be written as "1" where specifically indicated in this document.

2.12.2 NS32FX200, NS32FV100 and NS32FX100 Registers

MCFG rw | FE0A00

15	6	5	4	3	2	1	0
res	ESDC	EDMA0	ESCAN	EPBMS	ETPHB	ECOUNT	

TCU

CSCL w | FE0401

7	5	4	3	0
res		F		res

TIMER rw | FE0402

15	0
TIMER	

BUZCFG rw | FE0405

7	6	5	0
BCTRL	res		

BUZSWC w | FE0406

15	0
BUZSWC	

TSL r | FE0408

7	0
TSL	

WDC rw | FE040A

7	0
WDC	

MCLON w | FE040C

7	0
MCLON	

MCLOFF w | FE040E

7	0
MCLOFF	

2.0 Architecture (Continued)

ETC rw | FE0500

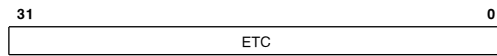

RFEN rw | FE0505 NS32FX200 and NS32FV100 only

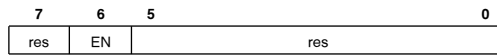

RFRT rw | FE0506 NS32FX200 and NS32FV100 only



SDC

SDCNTL rw | FE01E0

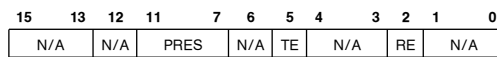

SDFTM rw | FE01E2

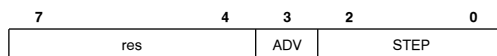

SDSTAT r* | FE01E4

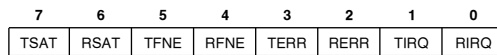

SDMASK rw | FE01E8

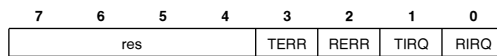

SDTX w | FE01EA

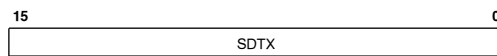

SDRX r | FE01EC

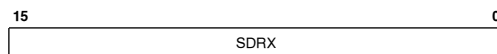

SDRGC rw | FE01F0



SDTGC rw | FE01F2

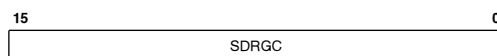

SCANC

SPP rw | FE0202

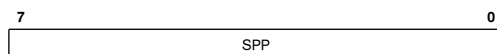

SDISD w | FE0204

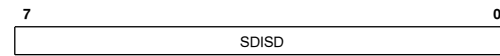

SDISW w | FE0206

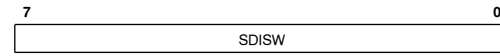

SNHD w | FE0208

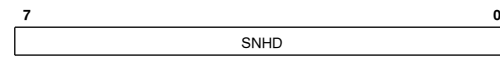

SNHW w | FE020A

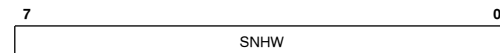

SLSD w | FE020C

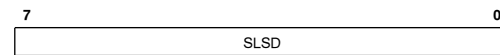

SLSW w | FE020E

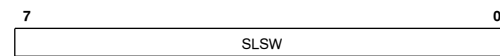

SAVWD w | FE0210

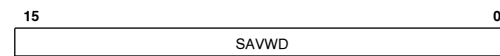

SAVWW w | FE0212

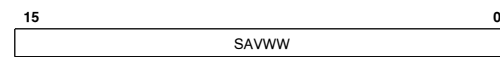

SPDWD w | FE0214

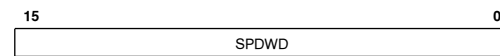

SPDWW w | FE0216

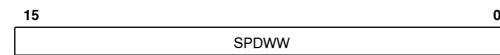

SMTSL rw | FE0218

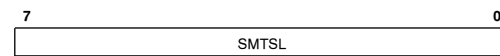

SITSL rw | FE021A

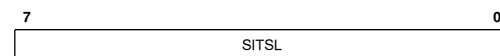

SGC rw | FE021F

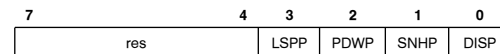

2.0 Architecture (Continued)

SCMPRW w | FE0220



SPRES w | FE0222

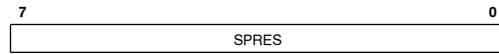

SVHC rw | FE0240

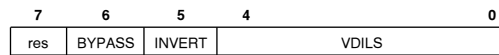

SVDB rw | FE0242

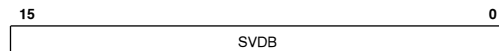

SBMS r | FE0244

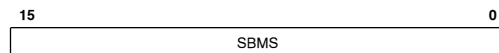

SDITH rw | FE028x

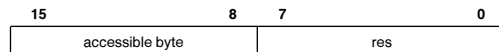

PRNTC

PBCFG rw | FE0301

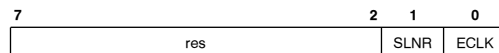

PACMP r | FE0304

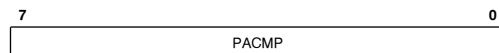

TPHC * | FE0308

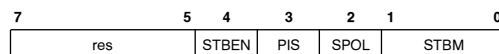

STBON w | FE0314

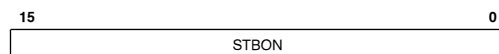

STBOFF w | FE0316

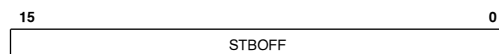

PSTSL rw | FE0318

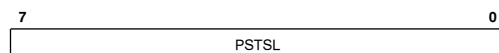

PMTSL rw | FE031A

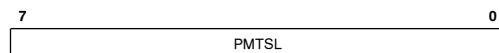

PDAC rw | FE031C

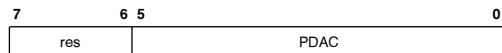

PCLON w | FE0330

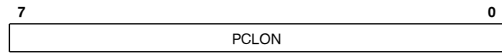

PCLOFF w | FE0332

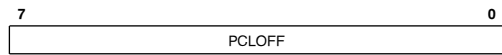

DMAC

ADCA0 rw | FFF020

ADCA1 rw | FFF040

ADCA2 rw | FFF060

ADCA3 rw | FFF080 NS32FX200 only

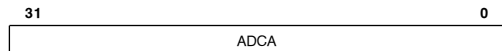

ADRA1 rw | FFF044

ADRA3 rw | FFF084 NS32FX200 only

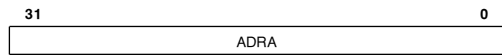

ADRB3 rw | FFF08C NS32FX200 only

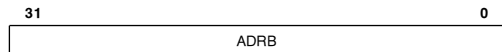

BLTC0 rw | FFF030

BLTC1 rw | FFF050

BLTC2 rw | FFF070

BLTC3 rw | FFF090 NS32FX200 only

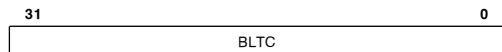

BLTR1 rw | FFF054

BLTR3 rw | FFF094 NS32FX200 only



MODE0 rw | FFF038

MODE1 rw | FFF058

MODE2 rw | FFF078

MODE3 rw | FFF098 NS32FX200 only

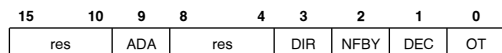

STAT0 * | FFF03C

STAT1 * | FFF05C

STAT2 * | FFF07C

STAT3 * | FFF09C NS32FX200 only

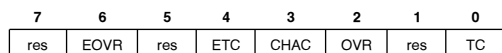

2.0 Architecture (Continued)

CNTL0 * | FFF03E
 CNTL1 * | FFF05E
 CNTL2 * | FFF07E
 CNTL3 * | FFF09E NS32FX200 only

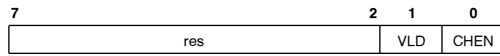

UART

UCNTL rw | FE0601

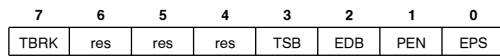

UMASK rw | FE0603

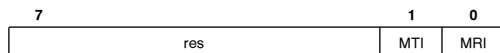

UCLST FE0607

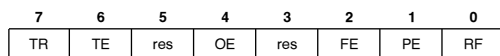

UBRGL rw | FE0609

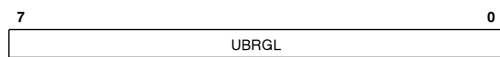

UBRGH rw | FE060B

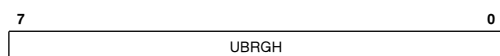

URXB r | FE060D



UTXB rw | FE060F



MWIRE

MWCSR * | FE0700

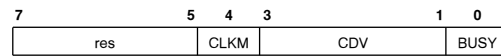

MWSIO rw | FE0704

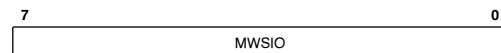

ICU

IVCT r | FFFE00

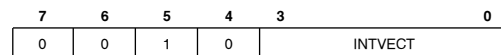

IELTG rw | FFFE08



ITRPL rw | FFFE0C



IPEND r | FFFE10



IENAM rw | FFFE14

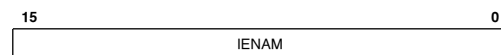

IECLR w | FFFE18



2.0 Architecture (Continued)

PORTS

PBDO rw | FE0812

7	6	5	4	3	2	1	0	
DMAK3	SDIS/ DMAK2	DMAK1	SCLK2/ DMAK0	STB3	STB2	STB1	STB0	
15				12	11	10	9	8
res				SLS	SCLK1	SPDW	MWSK	

PBMS rw | FE0814

15	12	11	10	9	8	7	6	5	4	3	2	1	0
res	MS11	MS10	MS9	MS8	MS7	MS6	MS5	MS4	MS3	MS2	MS1	MS0	

PBEN rw | FE0816

15												1	0
res												EN	

PADI r | FE0820

7				4	3	2	1	0
res				DMRQ3	MWSI	URXD	UTEN	

PAMS rw | FE0824

7						2	1	0
res						MS1	MS0	

PCDI r | FE0830

7	6	5	4	3	2	1	0
UREN	UTXD	MWSO	SBPYS/ DMRQ2	PCLK/ DMRQ1	SNH/ DMRQ0	PIO1	PIO0

PCDO rw | FE0832

7	6	5	4	3	2	1	0
UREN	UTXD	MWSO	SBPYS/ DMRQ	PCLK/ DMRQ1	SNH/ DMRQ0	PIO1	PIO0

PCMS rw | FE0834

7	6	5	4	3	2	1	0
MS7	MS6	MS5	MS4	MS3	MS2	res	

PCEN rw | FE0838

7	6	5	4	3	2	1	0
EN7	EN6	EN5	EN4	EN3	EN2	EN1	EN0

PEXT rw | FE0840

15														0
PEXT														

SMPH rw | FE0880

7												0
SMPH												

PMPH rw | FE0883

7												0
PMPH												

BMC

BMCFG rw | FE0910

7			3	2	1	0
res				DRA0	DPS	

MWAIT rw | FE0912

15	14	12	11	10	8	7	6	4	3	2	0
WAITR	WAIT3	IDLE2	WAIT2	IDLE1	WAIT1	IDLE0	WAIT0				

*Irregular behavior of some bit fields. See detailed description of the relevant module.

3.0 System Interface

3.1 POWER AND GROUNDING

The NS32FX100 requires a $5V \pm 10\%$ supply to nine digital pins and a $5V \pm 5\%$ supply to two analog pins. Two pins provide analog ground, nine pins provide digital ground.

3.2 CLOCKS AND TRAPS CONNECTIVITY

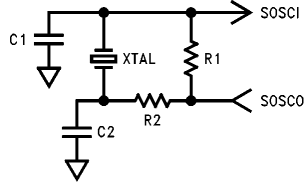

TL/EE/11331-33

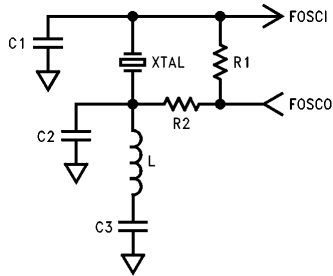

TL/EE/11331-34

FIGURE 3-2. Oscillator Circuits

TABLE 3-1. R, C and L Values

Frequency	R1	R2	C1 (pF)	C2 (pF)	C3 (pF)	L μ H
32.768 kHz	10 M Ω	1 M Ω	27	27		
455 kHz (ceramic)	1 M Ω	4.7 k Ω	22	100		
29.49–31.95 MHz	180 k Ω	51 Ω	22	22		
39.32–41.79 MHz	150 k Ω	51 Ω	22	22	1000	1.8
49.15 MHz	150 k Ω	51 Ω	22	22	1000	1.1

3.3 CONTROL OF POWER CONSUMPTION

An NS32FX100-based FAX-system controller is always in one of three modes:

1. Normal mode during a FAX transaction.
2. Power Save mode between FAX transactions. Power can be saved by running at a lower frequency and disabling unused modules.

In order to run at a lower frequency (the Normal mode frequency divided by 16), bit 4 of the CSCL register should be set to "1". Due to clock synchronization delays, up to 80 μ s may elapse between setting this bit and the actual change in running frequency.

3. Freeze mode, when the main power supply is turned off. A back-up battery is used to operate the NS32FX100 time keeper and, optionally, to maintain critical portions of the memory.

The following table summarizes the operation modes and their power consumption:

TABLE 3-2. System Chip Operation Modes and Power Consumption

Operation Mode	Current Consumption	ETC	DRAM Refresh*
Normal Mode	<200 mA	+	+
Power Save Mode @ ~1 MHz	<16 mA	+	+
Freeze Mode (5V)	<1 mA	+	+
Freeze Mode (32 kHz) (3V)	<0.1 mA	+	-

*NS32FX200, NS32FV100 only.

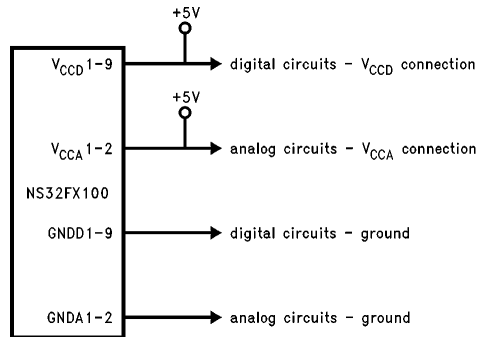

TL/EE/11331-32

FIGURE 3-1. Power and Ground Connections

3.0 System Interface (Continued)

3.4 BUS CYCLES

Memory transactions issued by the CPU and the NS32FX100 are almost identical. The transactions differ as follows:

1. During the CPU transactions, data is driven onto AD0–15 throughout T4, whereas, on DMA transactions by the NS32FX100, data is not driven onto AD0–15 to the end of T4.

2. The NS32FX100 does not drive \overline{HBE} and address on AD0–15 during T1.

3. The CPU drives \overline{ADS} in T1. The NS32FX100 drives \overline{ADS} from T1, preceding T1, through T1.

Read Transactions: \overline{WE}_i inactive; Only one \overline{SEL}_i or \overline{RAS}_i active. Write Transactions: \overline{OE} inactive; Only one \overline{SEL}_i or \overline{RAS}_i active.

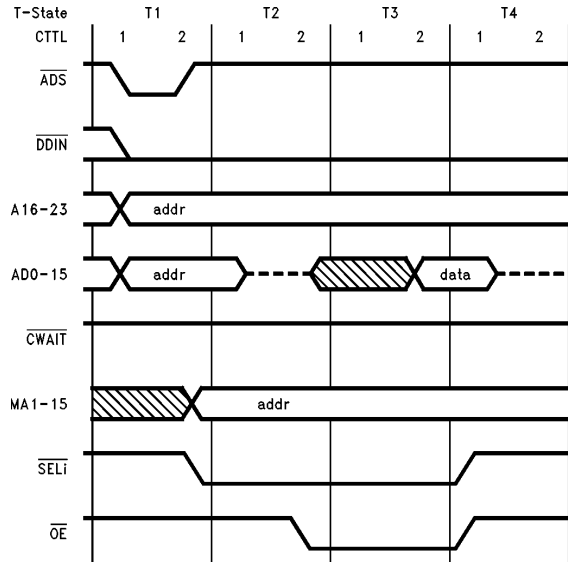

TL/EE/11331-35

FIGURE 3-3. Zones 0, 1 (ROM/SRAM) Read Transaction, Zero Wait State

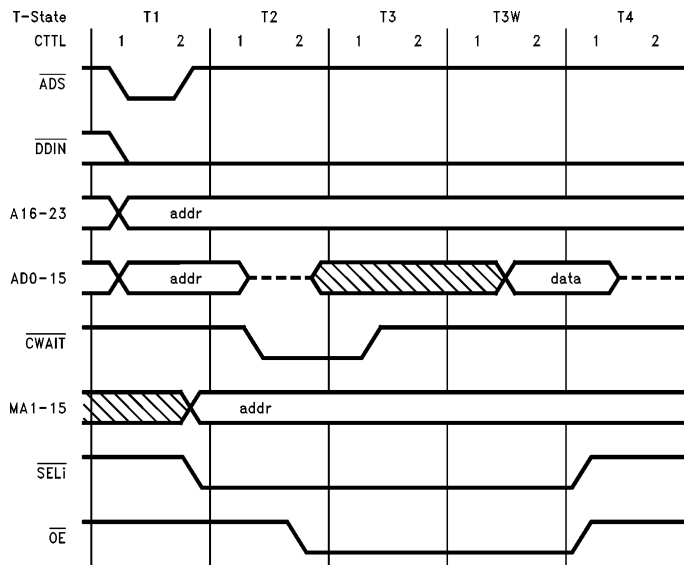

TL/EE/11331-36

FIGURE 3-4. Zones 0, 1 (ROM/SRAM) Read Transaction, One Wait State

3.0 System Interface (Continued)

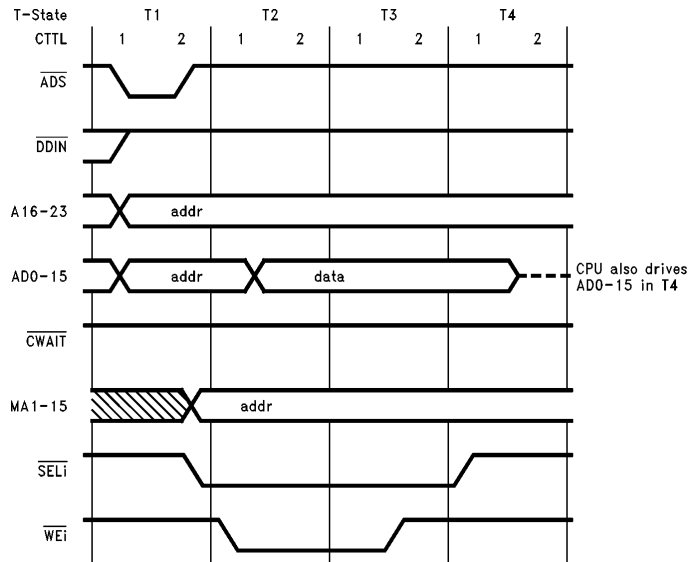

TL/EE/11331-37

FIGURE 3-5. Zones 0, 1 (ROM/SRAM) Write Transaction, Zero Wait State

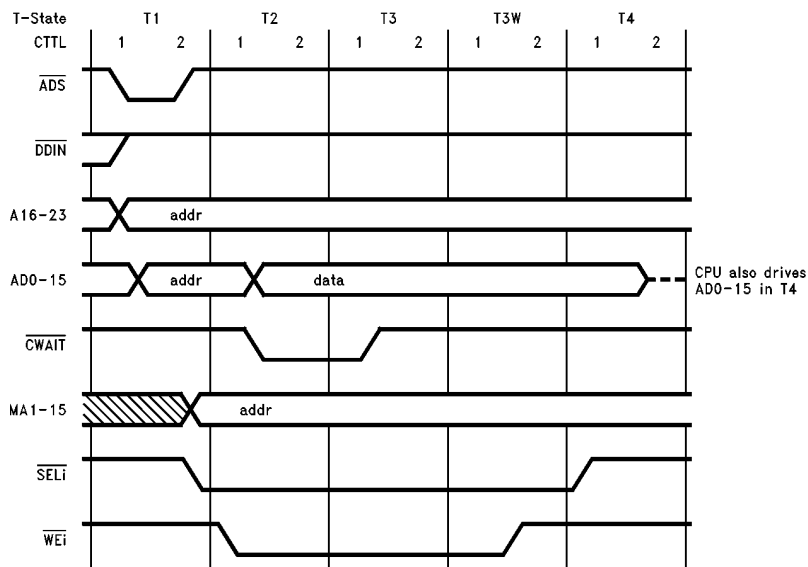

TL/EE/11331-38

FIGURE 3-6. Zones 0, 1 (ROM/SRAM) Write Transaction, One Wait State

3.0 System Interface (Continued)

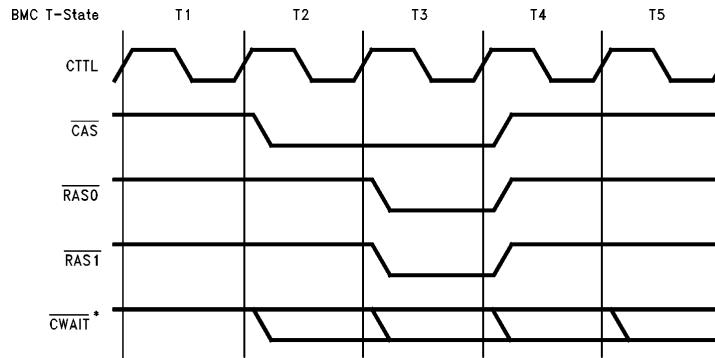

TL/EE/11331-39

FIGURE 3-7. Zone 2 (DRAM) Refresh Transaction, Zero Wait State

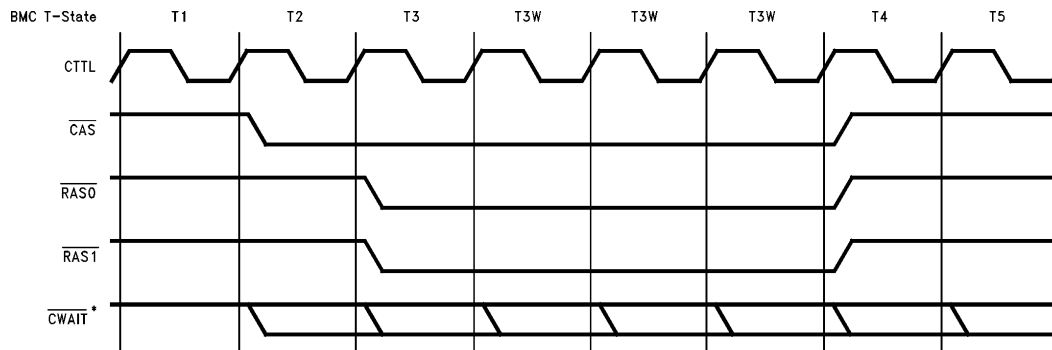

TL/EE/11331-40

*If a new CPU/DMA transaction to either Zone 0, 1 or 2 is started during the refresh transaction, it is postponed by $\overline{\text{CWAIT}}$ until the refresh is completed and for at least two more cycles (postponed T1, T2).

FIGURE 3-8. Zone 2 (DRAM) Refresh Transaction, Three Wait States

Figure 3-9 shows the Freeze Mode refresh transaction waveforms with RCFG.RFRT = 5.

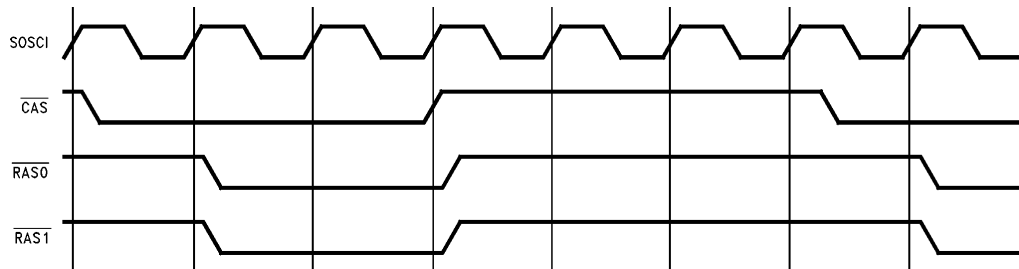

TL/EE/11331-41

FIGURE 3-9. Freeze Mode Refresh Transaction Waveform

3.0 System Interface (Continued)

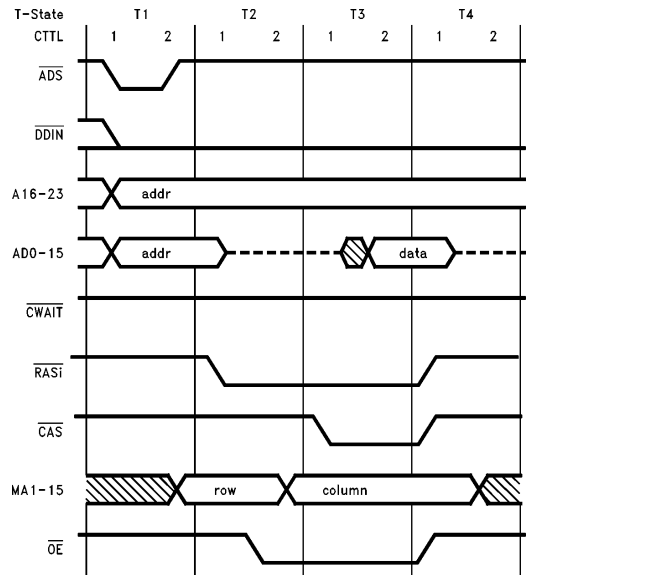
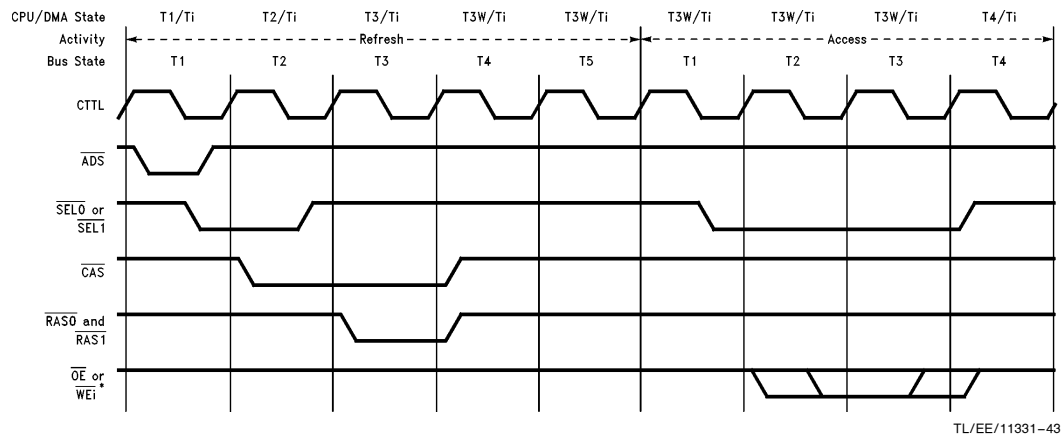

FIGURE 3-10. Zone 2 (DRAM) Read Transaction, Zero Wait State



(*) Note: \overline{OE} or \overline{WE}_i according to other Zone 0 or Zone 1 access figures.

FIGURE 3-11. Zones 0, 1 Access Delayed by a Refresh Transaction (No Wait)

3.0 System Interface (Continued)

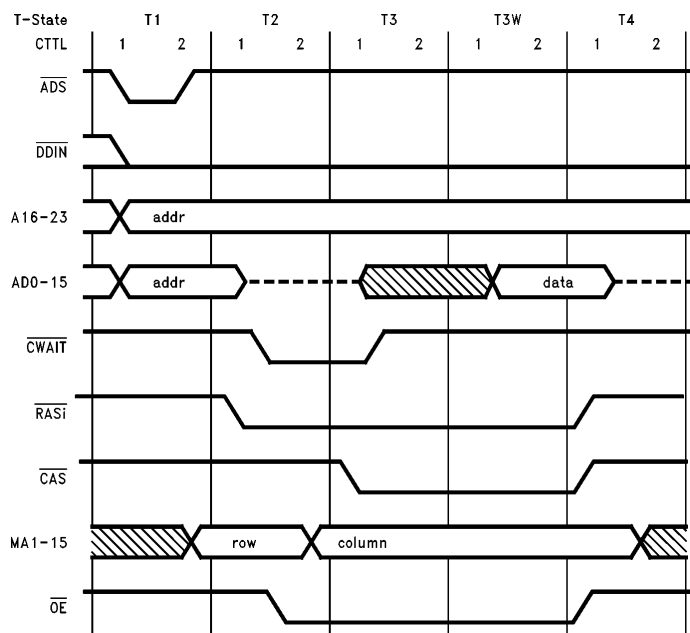

TL/EE/11331-44

FIGURE 3-12. Zone 2 (DRAM) Read Transaction, One Wait State

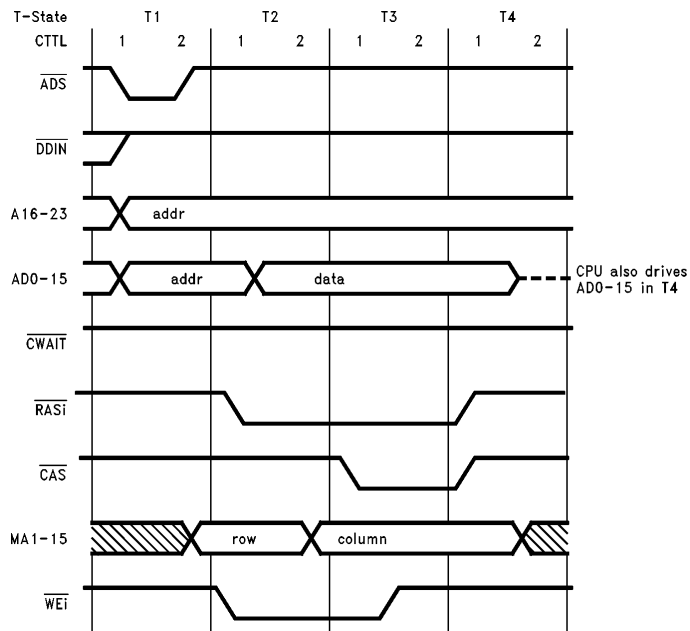

TL/EE/11331-45

FIGURE 3-13. Zone 2 (DRAM) Write Transaction, Zero Wait State

3.0 System Interface (Continued)

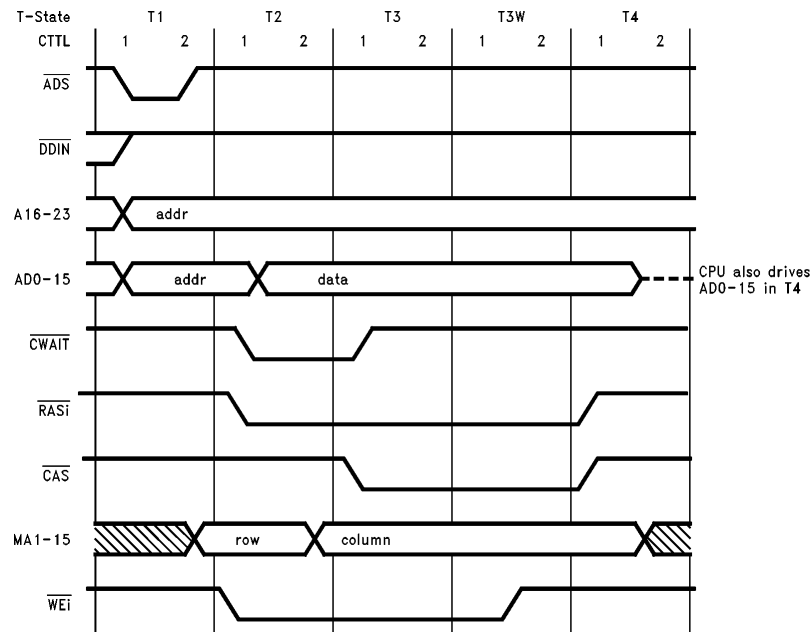

FIGURE 3-14. Zone 2 (DRAM) Write Transaction, One Wait State

TL/EE/11331-46

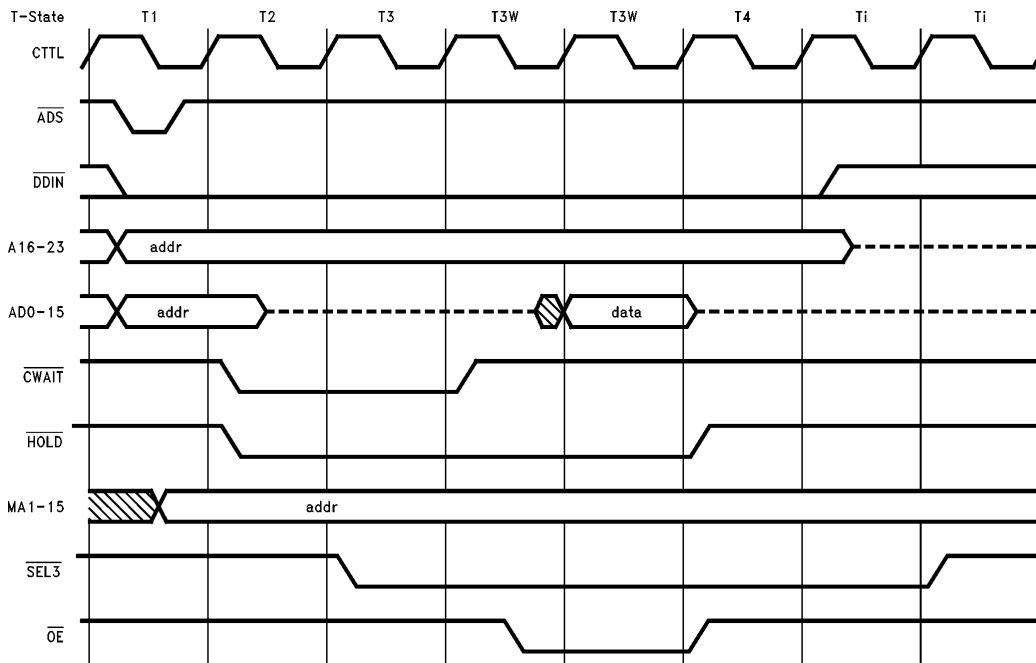

FIGURE 3-15. Zone 3 (I/O) Read Transaction, Two Wait States

TL/EE/11331-47

3.0 System Interface (Continued)

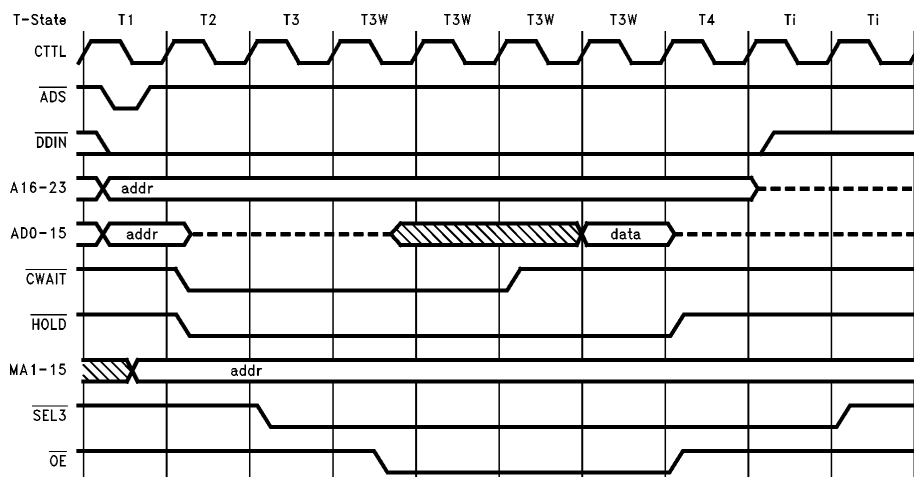
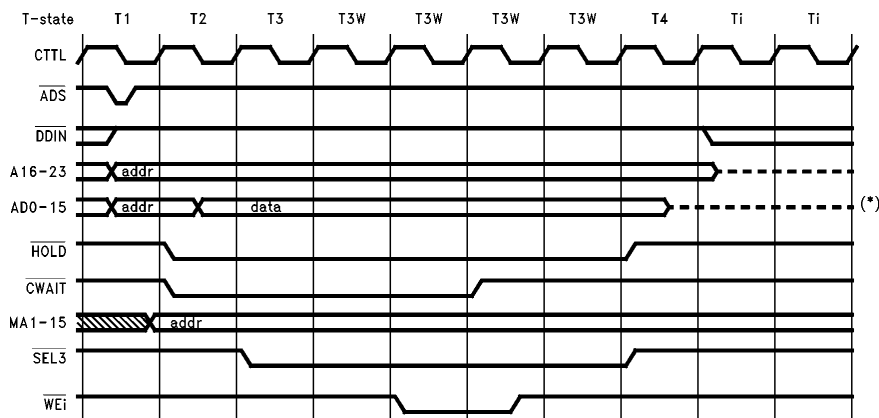

FIGURE 3-16. Zone 3 (I/O) Read Transaction, Four Wait States

TL/EE/11331-48



(*) CPU also drives A0-15 in T4

FIGURE 3-17. Zone 3 (I/O) Write Transaction, Four Wait States

TL/EE/11331-49

3.0 System Interface (Continued)

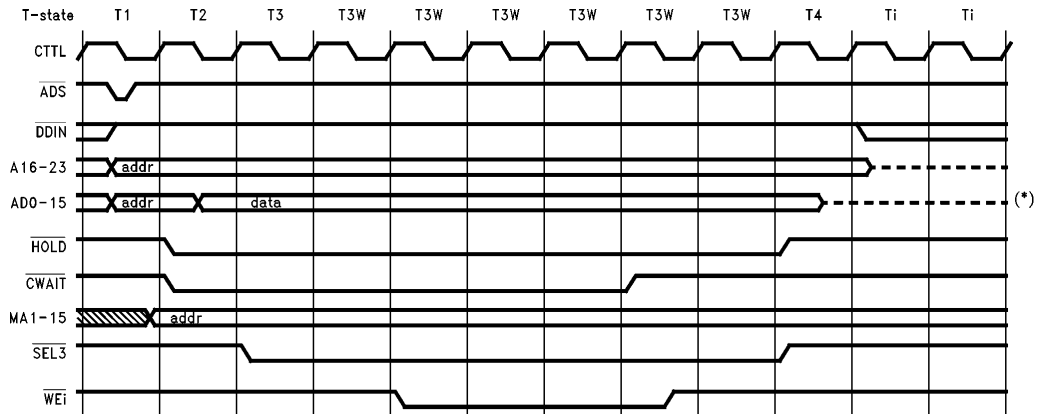

(*) CPU also drives AD0-15 in T4

TL/EE/11331-50

FIGURE 3-18. Zone 3 (I/O) Write Transaction, Six Wait States

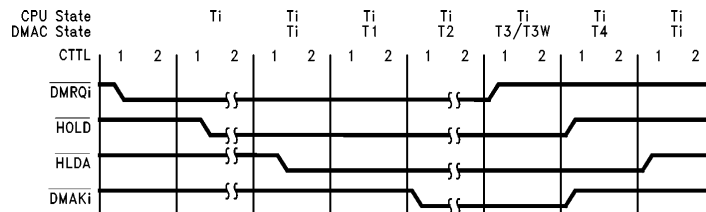

TL/EE/11331-51

FIGURE 3-19. CPU/DMA Arbitration

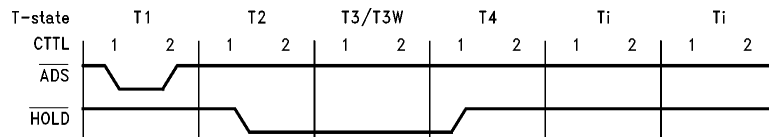

TL/EE/11331-52

FIGURE 3-20. Spaced Memory Transaction, Two Tides after T4

4.0 Device Specifications

4.1 NS32FX100 PIN DESCRIPTIONS

The following is a brief description of all NS32FX100 pins.

Some NS32FX100 pins have flexible allocation. These pins can be individually configured as general purpose pins even

when the module they belong to is enabled. The Ports module controls pin allocation.

Unless otherwise specified, all digital inputs and outputs are synchronous with the CTTL pin.

The following is a brief description of all NS32FX100 pins.

4.1.1 Supplies

Signal	Pin Numbers	Description
GND A1-2	77 82	Analog ground.
GND D1-9	11 25 38 51 75 90 102 116 131	Digital ground.
VCCA1-2	76 83	Analog Power —5V supply for analog circuits.
VCCD1-9	5 17 32 50 66 84 96 109 125	Digital Power —5V supply for digital circuits.

4.1.2 Input Signals

Signal	Pin Numbers	Description
CTTL	33	CPU Clock —CPU clock that is used for clocking the NS32FX100.
DMRQ3	58	DMA Request —Input for DMA channel 3 request or general purpose input pin.
FOSCI	36	High-Speed Oscillator —(31.9488 MHz–49.1520 MHz) Asynchronous. When an external oscillator is used, FOSCO should be left unconnected or loaded with no more than 5 pF of stray capacitance.
HBE	117	High Byte Enable —Status signal used to enable data transfers on the most significant byte of the data bus.
HLDA	114	Hold Acknowledge —Issued by the CPU to indicate it has released the bus in response to a HOLD request.
INT0–3	40 41 42 43	Interrupt In —Asynchronous. External maskable prioritized interrupt requests.
MWSI	57	MICROWIRE Serial In —Serial data for communication via the MICROWIRE protocol or general purpose input pin.
PFAIL	64	Power Fail Indication —An asynchronous signal which forces the NS32FX100 into freeze mode.
PTMP	81	Temperature Sense —An analog voltage proportional to the printer temperature.
RST	61	Reset In —Asynchronous reset input from the CPU.
SBG	80	Scanner Background —Analog current from the Automatic Background Control circuit (ABC).
SDIN	19	Sigma-Delta Data In —Asynchronous input from the SDC analog receiver.
SOSCI	62	Low-Speed Oscillator —(32.768 kHz or 455 kHz) Asynchronous. When an external oscillator is used, SOSCO should be left unconnected or loaded with no more than 5 pF of stray capacitance.
SVI	78	Scanner Video In —Analog current from the scanner sample and hold circuit.
URXD	56	UART Receive —Asynchronous input or general purpose input pin.
UTEN	55	UART Transmit Enable —Input, Asynchronous or general purpose input pin.

4.0 Device Specifications (Continued)

4.1.3 Output Signals

Signal	Pin Numbers	Description
BUZCLK	59	Buzzer Clock —Programmable frequency clock for the buzzer.
$\overline{\text{CAS}}$	104	DRAM Column Address Strobe —Column address strobe for DRAM banks refresh. (NS32FX200 and NS32FV100.)
CCLK	39	CPU Double Clock —Feeds CPU'S OSCIN. Asynchronous
$\overline{\text{CWAIT}}$	103	Continuous Wait —Low extends the memory cycle of the CPU.
$\overline{\text{DMAK1}}$	28	DMA Acknowledge —Output for DMA channel 1 acknowledge or general purpose output pin.
$\overline{\text{DMAK3}}$	26	DMA Acknowledge —Output for DMA channel 3 acknowledge or general purpose output pin.
FOSCO	37	High-Speed Oscillator Out —Asynchronous. This line is used as the return path for the crystal (if used).
HOLD	115	Hold Request —When low, HOLD requests the bus from the CPU to perform DMA operations or to insert idle bus cycles.
INTR	44	Interrupt Request —Low indicates that an interrupt request is being output to the CPU.
MA1–15	101 100 99 98 97 95 94 93 92 91 89 88 87 86 85	Memory Address Bus —Multiplexed DRAM address. (NS32FX200 and NS32FV100.)
MWSK	24	MICROWIRE Shift Clock —Output or general purpose output pin.
$\overline{\text{OE}}$	111	Output Enable —Used by the addressed device to gate the data onto the data bus.
PDO	16	Printer Bitmap Shifter Data —Output from the bitmap shifter.
PEXT	65	External Expansion Port Latch Enable.
PMPH0–3	74 73 72 71	Printer Motor Phases —Four phase signals for driving the printer motor.
$\overline{\text{RAS0}}$	106	DRAM Row Address Strokes —Row address strobe for DRAM banks 0 and 1. (NS32FX200 and NS32FV100.)
$\overline{\text{RAS1}}$	105	
SCLK1	22	Scanner Clock 1 —Output, pixel clock or general purpose output pin.
SCLK2/ $\overline{\text{DMAK0}}$	29	Scanner Clock 2 —Output, pixel clock or DMA Acknowledge—output for DMA channel 0 acknowledge or general purpose output pin.
SCVO	79	Scanner Compensated Video Out —Analog current for use by ABC or optional video enhancement circuit.
SDFDBK	18	Sigma-Delta Feedback —Feedback input to the SDC analog receiver. Asynchronous output signal.

4.0 Device Specifications (Continued)

4.1.3 Output Signals (Continued)

Signal	Pin Numbers	Description
SDIS/DMAK2	27	Discharge —Output signal used by the scanner to prepare for the next pixel or DMA Acknowledge—Output for DMA channel 2 acknowledge or general purpose output pin.
SDOUT	20	Sigma-Delta Data Out —Input to the SDC analog transmitter.
SEL0 SEL1 SEL3	108 110 107	Zone Select —Used to address the device according to the selected zone.
SLS	21	Scanner Line Sync —Output signal used to indicate beginning of scan or general purpose output pin.
SMPH0-3	70 69 68 67	Scanner Motor Phases —Four phase signals for driving the scanner motor.
SOSCO	63	Low-Speed Oscillator Out —Asynchronous. This line is used as the return path for the crystal (if used).
SPDW	23	Peak Detector Window —Output to the scanner ABC circuit or general purpose output pin.
STB0-3	35 34 31 30	Strobes —Thermal print head strobes output or general purpose output pin.
WDT	60	WATCHDOG Trap —Traps CPU execution when WATCHDOG detects error.
WE0 WE1	113 112	Write Enable —Used by the addressed device to gate the data from the data bus. WE0 for even and WE1 for odd bytes.

4.1.4 Input/Output Signals

Signal	Pin Numbers	Description
A16-23	7 8 9 10 12 13 14 15	High Order Address Bus —The most significant eight bits of the CPU address bus. Output from the NS32FX100 during DMA cycles.
AD0-15	120 121 122 123 124 126 127 128 129 130 132 1 2 3 4 6	Address/Data bus —Multiplexed address/ data information.
ADS	118	Address Strobe —Controls memory access, and signals the beginning of a bus cycle. Output from the NS32FX100 during DMA cycles.
DDIN	119	Data Direction In —Indicates the direction of data transfer during a bus cycle. Output from the NS32FX100 during DMA cycles.
MWSO	47	MICROWIRE Serial Out —Serial output data for communication via the MICROWIRE protocol or general purpose I/O pin.
PCLK/DMRQ1	49	Printer Bitmap Shift Clock —Output from the internal clock or asynchronous input from an external clock (NS32FX200 only) or input for DMA channel 1 request or general purpose I/O pin.
PIO0-1	54 53	General Purpose I/O Pins.
SBYPS/DMRQ2	48	Scanner Pixel Bypass —Input to pixel generator for external video enhancement device (NS32FX200 only) or last sampled pixel output or DMA Request—Input for DMA channel 2 request or general purpose I/O pin. (SBYPS in NS32FX200 only.)
SNH/DMRQ0	52	Sample and Hold —Output to scanner sample and hold circuit or DMA Request—input for DMA channel 0 request or general purpose I/O pin.
UREN	45	UART Receive Enable —Output or general purpose I/O pin.
UTXD	46	UART Transmit —Output or general purpose I/O pin.

4.0 Device Specifications (Continued)

4.2 OUTPUT SIGNAL LEVELS

The following tables show the levels of the NS32FX100 output control signals during reset or power save mode.

4.2.1 Freeze Mode Output Signals

Output signals are driven during Freeze mode (states S3, S4, S5) as follows:

Name	Output Level @ S3, S4, S5 *	Special Features
$\overline{\text{CWAIT}}$	TRI-STATE	$V_{OL} < 0.2V^*$
$\overline{\text{HOLD}}$	TRI-STATE	
MA1-15	Drive Low	
$\overline{\text{WE0-1}}$	TRI-STATE	
$\overline{\text{OE}}$	TRI-STATE	
$\overline{\text{SEL0}}$	TRI-STATE	
$\overline{\text{SEL1}}$	TRI-STATE	
$\overline{\text{SEL3}}$	TRI-STATE	
$\overline{\text{RAS0-1}}$	Toggle/drive low**	
$\overline{\text{CAS}}$	Toggle/drive low**	
SMPH0-3	TRI-STATE	
PMPH0-3	TRI-STATE	
PORT-B	T.S. according PBEN bit	
PDO	TRI-STATE	
BUZCLK	TRI-STATE	
WDT	TRI-STATE	
$\overline{\text{INTR}}$	TRI-STATE	
PEXT	TRI-STATE	
CCLK	Drive Low***	
AD0-15	TRI-STATE	
A16-23	TRI-STATE	
$\overline{\text{ADS}}$	TRI-STATE	
$\overline{\text{DDIN}}$	TRI-STATE	
PORT-C	T.S. according PCENx	2 Source T.S.
SDOUT	Drive Low****	CMOS
SDFDBK	Drive Low****	CMOS
SOSCO	Toggles	
FOSCO	Drive High	

*When MA1-15, $\overline{\text{CAS}}$, $\overline{\text{RAS0}}$ and $\overline{\text{RAS1}}$ are driven low, their voltages are below $\text{GND} + 0.2V$, if less than 0.1 mA is driven.

**When refresh is enabled, these signals are toggled. When refresh is disabled, these signals are driven low.

***When entering Freeze mode from full frequency.

****MCFG = H'80

4.2.2 Reset/Power Restore Output Signals

During state S6 of the Power Save mode, output signals are driven or floated either when reset is active or throughout the S6 state. Output signals are driven during S6 as follows:

Name	Output Level @ S6 *	Special Features	
$\overline{\text{CWAIT}}$	Drive High	$V_{OL} < 0.2V^{**}$	
$\overline{\text{HOLD}}$	Drive High		
MA1-15	Drive Low		
$\overline{\text{WE0-1}}$	Drive High		
$\overline{\text{OE}}$	Drive High		
$\overline{\text{SEL0}}$	Drive High		
$\overline{\text{SEL1}}$	Drive High		
$\overline{\text{SEL3}}$	Drive High		
$\overline{\text{RAS0-1}}$	Toggle—refresh		
$\overline{\text{CAS}}$	Toggle—refresh		
SMPH0-3	Drive Low		
PMPH0-3	Drive Low		
PORT-B	TRI-STATE		
PDO	Undefined		
BUZCLK	Drive Low		
WDT	Drive Low		
$\overline{\text{INTR}}$	Drive High		
PEXT	Drive High		
CCLK	Toggles		CMOS Level
AD0-15	TRI-STATE		
A16-23	TRI-STATE		
$\overline{\text{ADS}}$	TRI-STATE		
$\overline{\text{DDIN}}$	TRI-STATE		
PORT-C	TRI-STATE	2 Source T.S.	
SDOUT	Drive	CMOS	
SDFDBK	Drive	CMOS	
FOSCO	Toggles		
SOSCO	Toggles		

*When $\overline{\text{RST}}$ is active and $\overline{\text{PFAIL}}$ is non-active ($\overline{\text{PFAIL}} = 1$, $\overline{\text{RST}} = 0$)

**When MA1-15, $\overline{\text{CAS}}$, $\overline{\text{RAS0}}$ and $\overline{\text{RAS1}}$ are driven low, their voltages are below $\text{GND} + 0.2V$, if less than 0.1 mA is driven.

4.0 Device Specifications (Continued)

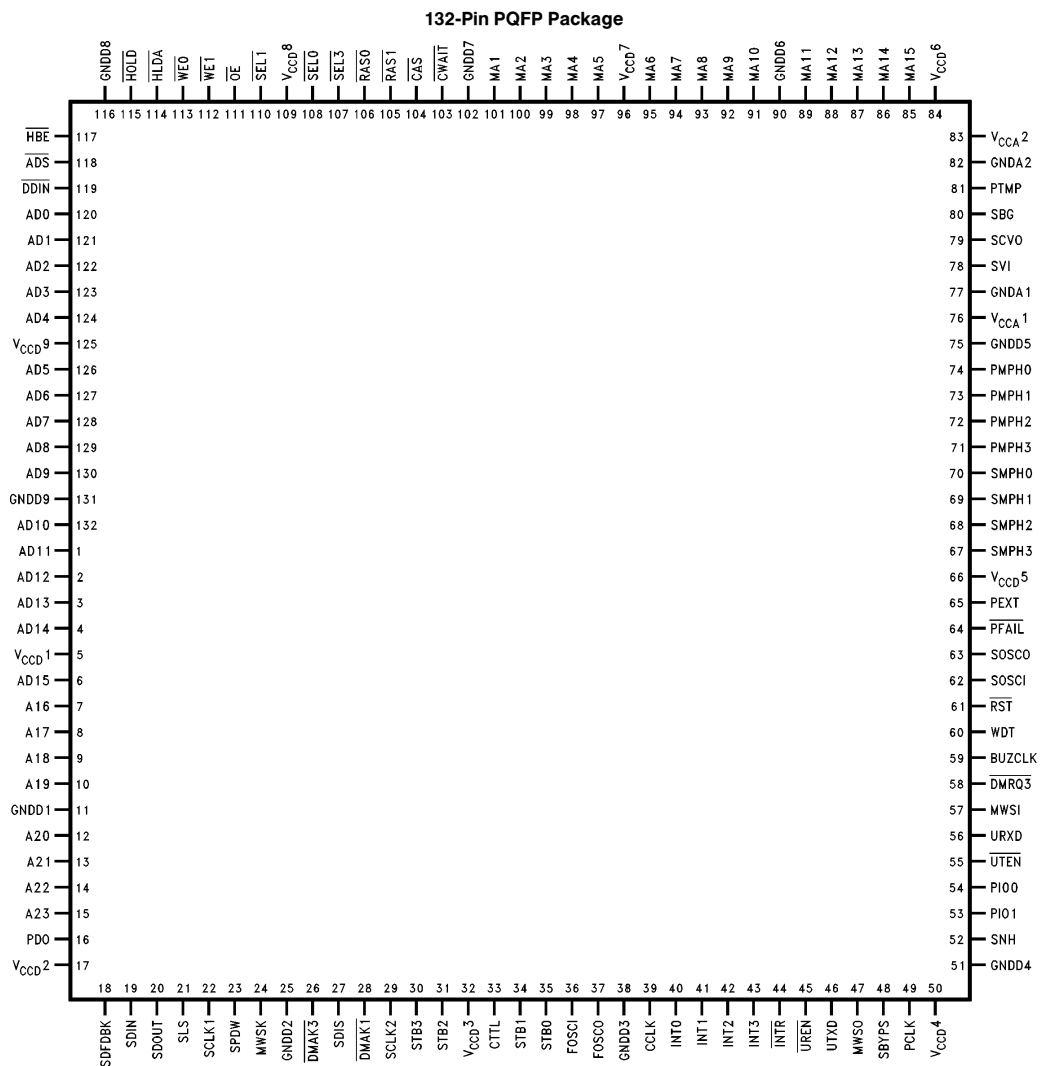

Top View
FIGURE 4-1. Connection Diagram

4.0 Device Specifications (Continued)

4.4 ELECTRICAL CHARACTERISTICS

$T_A = 0^\circ\text{C}$ to $+70^\circ\text{C}$, $V_{\text{CCD}} = 5\text{V} \pm 10\%$, $\text{GND} = 0\text{V}$ (Continued)

Symbol	Parameter	Conditions	Min	Typ	Max	Units
I_L	Leakage Current Output and I/O Pins in TRI-STATE or Input Mode	$0.4 \leq V_{\text{OUT}} \leq V_{\text{CCD}}$	-20		20	μA
I_{CCA}	Supply Current Digital Normal Mode	$I_{\text{OUT}} = 0$, $T_A = 25^\circ\text{C}$ 5V			170	mA
I_{CCAa}	Supply Current Analog Normal Mode	$I_{\text{OUT}} = 0$, $T_A = 25^\circ\text{C}$ 5V			32	mA
I_{CCi}	Supply Current Power Save Mode	1 MHz (Note 5) 5V			17	mA
I_{CCb5}	Supply Current Freeze Mode (Notes 4, 5)	5V 455 kHz Crystal			1	mA
I_{CCb4}	Supply Current Freeze Mode (Notes 4, 5)	5V 32.768 kHz Crystal			0.3	mA
I_{CCb3}	Supply Current Freeze Mode (Notes 4, 5)	3V 32.768 kHz Crystal			0.1	mA

Note 1: Designers should take care to provide a minimum inductance path between the GND pins and system ground, to minimize noise.

Note 2: Guaranteed by design.

Note 3: When $\overline{\text{MA1-15}}$, $\overline{\text{CAS}}$, $\overline{\text{RAS0}}$ and $\overline{\text{RAS1}}$ are driven low, their voltages are below $\text{GND} + 0.2\text{V}$, if less than 0.1 mA is driven. When $\overline{\text{OE}}$, $\overline{\text{SEL1}}$, $\overline{\text{WE0}}$ and $\overline{\text{WE1}}$ are driven high, their voltages are above $V_{\text{CCD}} - 0.2\text{V}$, if less than 0.1 mA is driven.

Note 4: The parameters I_{CCb5} , I_{CCb4} and I_{CCb3} are guaranteed by characterization. Due to tester conditions, these parameters are not 100% tested. I_{CCb5} , I_{CCb4} and I_{CCb3} are measured without load and assume INT0-3 , $\overline{\text{RST}}$, $\overline{\text{PFAIL}}$, and SDIN voltage levels less than 0.2V. SVI , PTMP and SBG currents are less than 0.1 μA . PCEN should be cleared to zero. $V_{\text{CCA}} = 0$.

Note 5: MCFG is H'80 and the DMA's CNTLi registers are cleared to zero, $I_{\text{OUT}} = 0$, $V_{\text{IH}} = 3.5\text{V}$.

4.0 Device Specifications (Continued)

4.5 ANALOG ELECTRICAL CHARACTERISTICS

$T_A = 0^\circ\text{C}$ to $+70^\circ\text{C}$, $V_{CCA} = 5\text{V} \pm 5\%$, $A_{GND} = 0\text{V}$

Video MDAC

Resolution	8 Bits
Monotonicity	8 Bits
Nonlinearity @ $I_{REF} = 4\text{ mA}$	8 Bits
I_{OFF} Range	$0 - \pm 15$ current units of app. $8\ \mu\text{A}$
I_{OFF} Accuracy	a current unit is $8\ \mu\text{A} + 150\% / -20\%$
Zero Scale I_{OUT}	Typical: $1.2\ \mu\text{A}$, Max: $12\ \mu\text{A}$
Output Voltage Compliance	max 2.5V
SVI Range	$0\text{ mA} - 4\text{ mA}$

Threshold MDAC

Resolution	8 Bits
Monotonicity	8 Bits
Nonlinearity @ $I_{REF} = 4\text{ mA}$	8 Bits
SBG Range	$0\text{ mA} - 4\text{ mA}$

Current Comparator

*Resolution	$8\ \mu\text{A}$ @ I_{OUT} internal $\geq 100\ \mu\text{A}$
*Output Polarity	"1" when Video DAC output $>$ Threshold DAC output

6 Bits PWM A/D Converter

*Resolution	6 Bits, (FS = 5V , $1/2\text{ LSB} = 40\text{ mV}$)
*VIN Voltage Compliance	$0\text{V} - 3.5\text{V}$
*Max Conversion Time	5 ms
*Input Load Current	min $-20\ \mu\text{A}$, max $20\ \mu\text{A}$

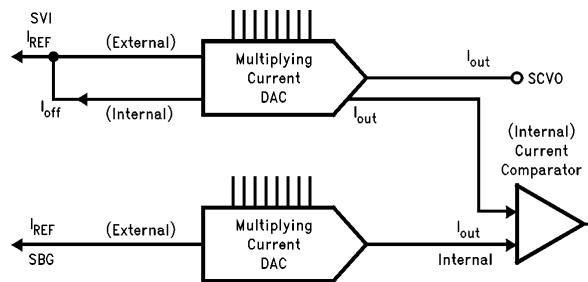

TL/EE/11331-60

For I_{REF} in the range of $0\text{ mA} - 4\text{ mA}$, the voltage on SVI (forced by the NS32FX200) will be greater than 1.5V .

FIGURE 4-2. Analog Circuitry Block Diagram

4.0 Device Specifications (Continued)

4.6 SWITCHING CHARACTERISTICS

4.6.1 Definitions

All the timing specifications given in this section refer to 0.8V or 2.0V on the rising or falling edges of all the signals, as illustrated in the following *Figures 4-3 to 4-5* unless specifically stated otherwise. The capacitive load is assumed to be 20 pF on the CCLK and 50 pF on all the other output signals.

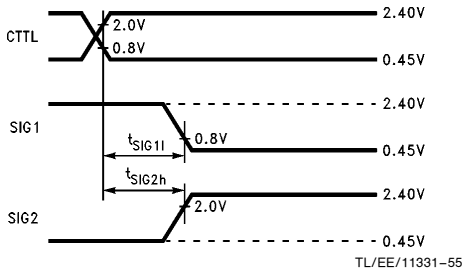

FIGURE 4-3. TTL—Output Signals Specification Standard

Abbreviations:

L.E.—Leading Edge
T.E.—Trailing Edge

R.E.—Rising Edge
F.E.—Falling Edge

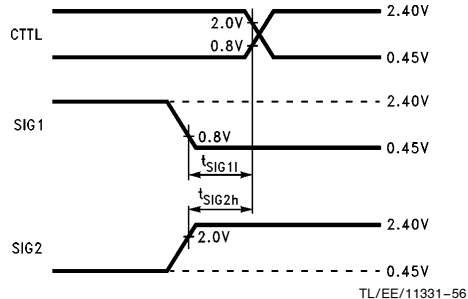

FIGURE 4-4. TTL—Input Signals Specification Standard

Abbreviations

Reference to Signal	Reference to Clock
L.E.—Leading Edge	R.E.—Rising Edge
T.E.—Trailing Edge	F.E.—Falling Edge

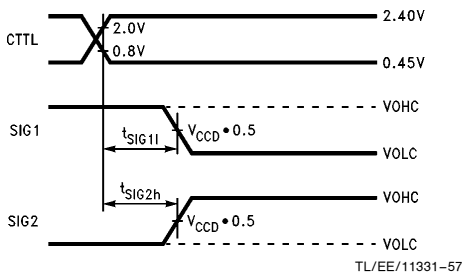

FIGURE 4-5. CMOS—Output Signals Specification Standard

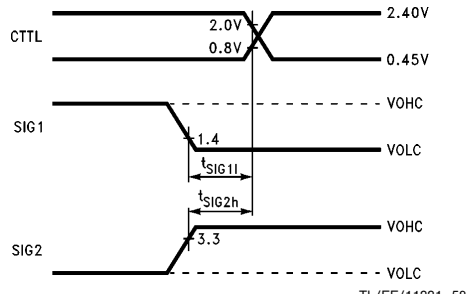

FIGURE 4-6. CMOS—Input Signals Specification Standard

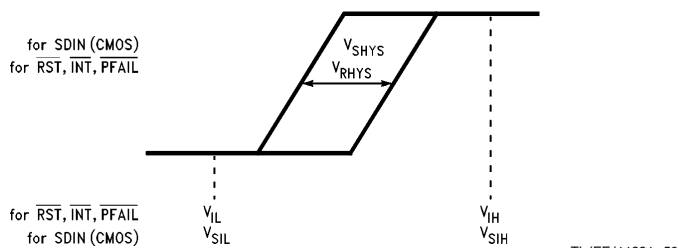

FIGURE 4-7. Input Hysteresis

4.0 Device Specifications (Continued)

4.6.2 Timing Tables

4.6.2.1 Output Signals: Internal Propagation Delays

Symbol	Figure	Description	Reference/ Condition	NS32FX200-15		NS32FX200-20		NS32FX200-25		Units
				Min	Max	Min	Max	Min	Max	
t _{CLKp}	4-8	CCLK Clock Period	R.E. CCLK to next R.E. CCLK	33	500	25	500	20	500	ns
t _{CLKh}	4-8	CCLK High Time	At 3.8V (Both Edges)	t _{CLKp/2} - 5 ns		t _{CLKp/2} - 4 ns		t _{CLKp/2} - 3 ns		
t _{CLKl}	4-8	CCLK Low Time	At 1.0V (Both Edges)	t _{CLKp/2} - 5 ns		t _{CLKp/2} - 4 ns		t _{CLKp/2} - 3 ns		
t _{CWa}	4-9	$\overline{\text{CWAIT}}$ Signal Active	After R.E., CTTL		40		30		24	ns
t _{CWi}	4-9	$\overline{\text{CWAIT}}$ Signal Inactive	After R.E., CTTL		40		30		24	ns
t _{ADSOa}	4-16	$\overline{\text{ADS}}$ Signal Active (Notes 2, 5)	After R.E., CTTL	t _{CTP/2} + 3	t _{CTP/2} + 27	t _{CTP/2} + 3	t _{CTP/2} + 25	t _{CTP/2} + 3	t _{CTP/2} + 23	ns
t _{ADSOia}	4-16	$\overline{\text{ADS}}$ Signal Inactive	After R.E., CTTL	t _{CTP/2}	t _{CTP/2} + 27	t _{CTP/2}	t _{CTP/2} + 25	t _{CTP/2}	t _{CTP/2} + 23	ns
t _{DDINv}	4-16	$\overline{\text{DDIN}}$ Signal Valid	Before F.E., CTTL T1		17		16		12	ns
t _{DDINh}	4-16	$\overline{\text{DDIN}}$ Signal Hold	After F.E., CTTL T4	0		0		0		ns
t _{HOLDa}	4-16	$\overline{\text{HOLD}}$ Signal Active	After R.E., CTTL		23		21		18	ns
t _{HOLDia}	4-16	$\overline{\text{HOLD}}$ Signal Inactive	After R.E., CTTL		23		21		18	ns
t _{MAv}	4-9	MA1-15 Valid (Note 3)	After R.E., CTTL T1		50		36		34	ns
t _{MACv}	4-9	MA1-15 Valid Column Address	After R.E., CTTL T2		60		45		40	ns
t _{MAh}	4-9	MA1-15 Hold	After R.E., CTTL T2 or T4	t _{CTP/2} + 0 ns		t _{CTP/2} + 0 ns		t _{CTP/2} + 0 ns		ns
t _{RAh}	4-9	MA1-15 Hold (Notes 4, 5)	After F.E., RAS	25		18		14		ns
t _{ADv}	4-17	AD0-15 Valid (Data) (Note 1)	After R.E., CTTL T2	t _{CTP/2}	t _{CTP/2} + 25	t _{CTP/2}	t _{CTP/2} + 20	t _{CTP/2}	t _{CTP/2} + 20	ns
t _{ADs}	4-17	AD0-15 Setup (Data) (Note 5)	Before R.E., WE0-1	40		30		18		ns
t _{ADh}	4-17	AD0-15 Hold (Data)	After R.E., CTTL T4	t _{CTP/2}		t _{CTP/2}		t _{CTP/2}		ns

Note 1: t_{CASa} - t_{ADv} ≥ 7 ns. Guaranteed by design.

Note 2: t_{CTP} is the first parameter on the input signal list.

Note 3: Generated asynchronous to CTTL as a function of the inputs AD0-15, A16-23, and $\overline{\text{ADS}}$.

Note 4: Assuming MA1-15 load > RAS load.

Note 5: Guaranteed by characterization. Due to tester conditions, these parameters are not 100% tested.

4.0 Device Specifications (Continued)

4.6.2 Timing Tables (Continued)

4.6.2.1 Output Signals: Internal Propagation Delays (Continued)

Symbol	Figure	Description	Reference/ Condition	NS32FX200-15		NS32FX200-20		NS32FX200-25		Units
				Min	Max	Min	Max	Min	Max	
t _{AHv}	4-16	A16-23 Valid	After R.E., CTTL T1		50		36		32	ns
t _{AHh}	4-16	A16-23 Hold	After R.E., CTTL T4 or Ti	0		0		0		ns
t _{WEa}	4-10	$\overline{WE0-1}$ Signal Active	After R.E., CTTL		20		17		17	ns
t _{WEia}	4-10	$\overline{WE0-1}$ Signal Inactive	After R.E., CTTL	t _{CTP/2}	t _{CTP/2} + 20	t _{CTP/2}	t _{CTP/2} + 17	t _{CTP/2}	t _{CTP/2} + 17	ns
t _{WEw}	4-10	$\overline{WE0-1}$ Pulse Width (Note 2)	At 0.8V (both edges)	80		61		45		ns
t _{CWh}	4-10	$\overline{WE0-1}$ Signal Hold (Notes 1, 2)	After F.E., \overline{CAS}	20		15		10		ns
t _{OEa}	4-9	\overline{OE} Signal Active	After R.E., CTTL	t _{CTP/2}	t _{CTP/2} + 20	t _{CTP/2}	t _{CTP/2} + 16	t _{CTP/2}	t _{CTP/2} + 16	ns
t _{OEia}	4-9	\overline{OE} Signal Inactive	After R.E., CTTL		20		16		16	ns
t _{SEL0a}	4-11	$\overline{SEL0}$ Signal Active (Note 3)	After R.E., CTTL T1		50		36		33	ns
t _{SEL0ia}	4-11	$\overline{SEL0}$ Signal Inactive	After R.E., CTTL T4		24		22		20	ns
t _{SEL1a}	4-11	$\overline{SEL1}$ Signal Active (Note 3)	After R.E., CTTL T1		50		36		33	ns
t _{SEL1ia}	4-11	$\overline{SEL1}$ Signal Inactive	After R.E., CTTL T4		24		22		20	ns
t _{SEL3a}	4-13	$\overline{SEL3}$ Signal Active	After R.E., CTTL		20		18		18	ns
t _{SEL3ia}	4-13	$\overline{SEL3}$ Signal Inactive	After R.E., CTTL		24		22		20	ns
t _{RASa}	4-9	$\overline{RAS0-1}$ Signal Active	After R.E., CTTL		20		17		17	ns
t _{RASia}	4-9	$\overline{RAS0-1}$ Signal Inactive	After R.E., CTTL		20		17		17	ns
t _{RCa}	4-9	\overline{CAS} Signal Active (Note 2)	After F.E., $\overline{RAS0-1}$	46		33		25		ns
t _{RCLa}	4-9	\overline{CAS} Signal Active (Notes 2, 4)	After F.E., $\overline{RAS0-1}$	50		40		30		ns
t _{CASa}	4-9	\overline{CAS} Signal Active	After R.E., CTTL		20		16		16	ns
t _{CASia}	4-9	\overline{CAS} Signal Inactive	After R.E., CTTL		20		16		16	ns

Note 1: Assuming $\overline{WE0-1}$ load > \overline{CAS} load.

Note 2: Guaranteed by characterization. Due to tester conditions, these parameters are not 100% tested.

Note 3: Generated asynchronous to CTTL as a function of the inputs AD0-15, A16-23, and \overline{ADS} .

Note 4: Assuming \overline{CAS} load > \overline{RAS} load.

4.0 Device Specifications (Continued)

4.6.2 Timing Tables (Continued)

4.6.2.1 Output Signals: Internal Propagation Delays (Continued)

Symbol	Figure	Description	Reference/ Condition	NS32FX200-15		NS32FX200-20		NS32FX200-25		Units
				Min	Max	Min	Max	Min	Max	
t _{RASBBa}	4-15	$\overline{RAS0-1}$ Signal Active (Freeze Mode)	After R.E., SOSCI at 3.8V		100		100		100	ns
t _{RASBBia}	4-15	$\overline{RAS0-1}$ Signal Active (Freeze Mode)	After R.E., SOSCI at 3.8V		100		100		100	ns
t _{CASBBa}	4-15	\overline{CAS} Signal Active (Freeze Mode)	After R.E., SOSCI at 3.8V		100		100		100	ns
t _{CASBBia}	4-15	\overline{CAS} Signal Active (Freeze Mode)	After R.E., SOSCI at 3.8V		100		100		100	ns
t _{SDOUTv}	4-19	SDOUT Signal Valid	After R.E., CTTL		14		13		12	ns
t _{SDOUTh}	4-19	SDOUT Signal Hold	After R.E., CTTL	0		0		0		ns
t _{SDFDBkv}	4-19	SDFDBK Signal Valid	After R.E., CTTL		14		13		12	ns
t _{SDFDBkh}	4-19	SDFDBK Signal Hold	After R.E., CTTL	0		0		0		ns
t _{SCVOv}	4-27	SCVO Signal Valid (Note 1)	After Input Change		300		300		300	ns
t _{SPDWa}	4-23	SPDW Signal Active	After R.E., CTTL		24		22		20	ns
t _{SPDWia}	4-23	SPDW Signal Inactive	After R.E., CTTL		24		22		20	ns
t _{SDISa}	4-23	SDIS Signal Active	After R.E., CTTL		24		22		20	ns
t _{SDISia}	4-23	SDIS Signal Inactive	After R.E., CTTL		24		22		20	ns
t _{SLSa}	4-23	SLS Signal Active	After R.E., CTTL		24		22		20	ns
t _{SLSia}	4-23	SLS Signal Inactive	After R.E., CTTL		24		22		20	ns
t _{SCLK1a}	4-23	SCLK1 Signal Active	After R.E., CTTL		24		22		20	ns
t _{SCLK1ia}	4-23	SCLK1 Signal Inactive	After R.E., CTTL		24		22		20	ns
t _{SCLK2a}	4-23	SCLK2 Signal Active	After R.E., CTTL		24		22		20	ns
t _{SCLK2ia}	4-23	SCLK2 Signal Inactive	After R.E., CTTL		24		22		20	ns

Note 1: Input change in either: Digital input @ L.E. of SNH—Cycle.
Analog input SVI, measured at 30 pF.

4.0 Device Specifications (Continued)

4.6.2 Timing Tables (Continued)

4.6.2.1 Output Signals: Internal Propagation Delays (Continued)

Symbol	Figure	Description	Reference/ Condition	NS32FX200-15		NS32FX200-20		NS32FX200-25		Units
				Min	Max	Min	Max	Min	Max	
t _{SMPHa}	4-23	SMPH0-3 Signal Active	After R.E., CTTL		24		22		20	ns
t _{SMPHia}	4-23	SMPH0-3 Signal Inactive	After R.E., CTTL		24		22		20	ns
t _{STBa}	4-21	STB0-3 Signal Active	After R.E., CTTL	t _{CTp2}	t _{CTp2} + 24	t _{CTp2}	t _{CTp2} + 22	t _{CTp2}	t _{CTp2} + 20	ns
t _{STBia}	4-21	STB0-3 Signal Inactive	After R.E., CTTL	t _{CTp/2}	t _{CTp/2} + 24	t _{CTp/2}	t _{CTp/2} + 22	t _{CTp/2}	t _{CTp/2} + 20	ns
t _{PMPHa}	4-21	PMPH0-3 Signal Active	After R.E., CTTL		24		22		20	ns
t _{PMPHia}	4-21	PMPH0-3 Signal Inactive	After R.E., CTTL		24		22		20	ns
t _{BUZCLKa}	4-26	BUZCLK Signal Active	After R.E., CTTL	t _{CTp/2}	t _{CTp/2} + 24	t _{CTp/2}	t _{CTp/2} + 22	t _{CTp/2}	t _{CTp/2} + 20	ns
t _{BUZCLKia}	4-26	BUZCLK Signal Inactive	After R.E., CTTL	t _{CTp/2}	t _{CTp/2} + 24	t _{CTp/2}	t _{CTp/2} + 22	t _{CTp/2}	t _{CTp/2} + 20	ns
t _{WDTa}	4-22	WDT Signal Active	After R.E., CTTL		24		22		20	ns
t _{INTRa}	4-18	INTR Signal Active	After R.E., CTTL	t _{CTp/2}	t _{CTp/2} + 24	t _{CTp/2}	t _{CTp/2} + 22	t _{CTp/2}	t _{CTp/2} + 20	ns
t _{INTRia}	4-18	INTR Signal Inactive	After R.E., CTTL	t _{CTp/2}	t _{CTp/2} + 24	t _{CTp/2}	t _{CTp/2} + 22	t _{CTp/2}	t _{CTp/2} + 20	ns
t _{MWSKa}	4-25	MWSK Signal Active	After R.E., CTTL	t _{CTp/2}	t _{CTp/2} + 24	t _{CTp/2}	t _{CTp/2} + 22	t _{CTp/2}	t _{CTp/2} + 20	ns
t _{MWSKia}	4-25	MWSK Signal Active	After R.E., CTTL	t _{CTp/2}	t _{CTp/2} + 24	t _{CTp/2}	t _{CTp/2} + 22	t _{CTp/2}	t _{CTp/2} + 20	ns
t _{DMAKa}	4-16	DMAK0-3 Signal Active	After R.E., CTTL		24		22		20	ns
t _{DMAKia}	4-16	DMAK0-3 Signal Inactive	After R.E., CTTL		24		22		20	ns
t _{PEXTa}	4-26	PEXT Signal Active	After R.E., CTTL		24		22		22	ns
t _{PEXTia}	4-26	PEXT Signal Inactive	After R.E., CTTL		24		22		22	ns
t _{PDOEv}	4-21	PDO Signal Valid, (External Clock Mode)	After F.E., PCLK Input		33		33		33	ns
t _{PDOiv}	4-21	PDO Signal Valid, (Internal Clock Mode)	After R.E., CTTL (Note 1)		26		24		22	ns
t _{PCLKa}	4-21	PCLK Signal Active	After R.E., CTTL	t _{CTp/2}	t _{CTp/2} + 24	t _{CTp/2}	t _{CTp/2} + 22	t _{CTp/2}	t _{CTp/2} + 20	ns
t _{PCLKia}	4-21	PCLK Signal Inactive	After R.E., CTTL	t _{CTp/2}	t _{CTp/2} + 24	t _{CTp/2}	t _{CTp/2} + 22	t _{CTp/2}	t _{CTp/2} + 20	ns

Note 1: PDO is changed on the first CTTL R.E. following the PCLK F.E.

4.0 Device Specifications (Continued)

4.6.2 Timing Tables (Continued)

4.6.2.1 Output Signals: Internal Propagation Delays (Continued)

Symbol	Figure	Description	Reference/ Condition	NS32FX200-15		NS32FX200-20		NS32FX200-25		Units
				Min	Max	Min	Max	Min	Max	
t _{UTXD_a}	4-24	UTXD Signal Active	After R.E., CTTL	t _{CTP/2}	t _{CTP/2} + 24	t _{CTP/2}	t _{CTP/2} + 22	t _{CTP/2}	t _{CTP/2} + 20	ns
t _{UTXD_{ia}}	4-24	UTXD Signal Inactive	After R.E., CTTL	t _{CTP/2}	t _{CTP/2} + 24	t _{CTP/2}	t _{CTP/2} + 22	t _{CTP/2}	t _{CTP/2} + 20	ns
t _{UREN_a}	4-24	UREN Signal Active	After R.E., CTTL	t _{CTP/2}	t _{CTP/2} + 24	t _{CTP/2}	t _{CTP/2} + 22	t _{CTP/2}	t _{CTP/2} + 20	ns
t _{UREN_{ia}}	4-24	UREN Signal Inactive	After R.E., CTTL	t _{CTP/2}	t _{CTP/2} + 24	t _{CTP/2}	t _{CTP/2} + 22	t _{CTP/2}	t _{CTP/2} + 20	ns
t _{MWSO_a}	4-25	MWSO Signal Active (Note 1)	After R.E., CTTL		24		22		20	ns
t _{MWSO_{ia}}	4-25	MWSO Signal Inactive (Note 1)	After R.E., CTTL		24		22		20	ns
t _{PIO_a}	4-26	PIO0-1 Signal Active	After R.E., CTTL	t _{CTP/2}	t _{CTP/2} + 24	t _{CTP/2}	t _{CTP/2} + 22	t _{CTP/2}	t _{CTP/2} + 20	ns
t _{PIO_{ia}}	4-26	PIO0-1 Signal Inactive	After R.E., CTTL	t _{CTP/2}	t _{CTP/2} + 24	t _{CTP/2}	t _{CTP/2} + 22	t _{CTP/2}	t _{CTP/2} + 20	ns
t _{SNH_a}	4-23	SNH Signal Active	After R.E., CTTL		24		22		20	ns
t _{SNH_{ia}}	4-23	SNH Signal Inactive	After R.E., CTTL		24		22		20	ns
t _{SBYPS_a}	4-23	SBYPS Signal Active	After R.E., CTTL		24		22		20	ns
t _{SBYPS_{ia}}	4-23	SBYPS Signal Inactive	After R.E., CTTL		24		22		20	ns
t _{AL_f}	4-17	AD0-AD15 Floating (Note 4)	After R.E., CTTL Ti		15		14		13	ns
t _{AH_f}	4-17	A16-A23 Floating (Notes 3, 4)	After R.E., CTTL Ti		t _{CTP/2}		t _{CTP/2}		t _{CTP/2}	ns
t _{ADS_f}	4-17	ADS Signal Floating (Notes 3, 4)	After R.E., CTTL Ti		t _{CTP/2}		t _{CTP/2}		t _{CTP/2}	ns
t _{DDIN_f}	4-17	DDIN Signal Floating (Notes 3, 4)	After R.E., CTTL Ti		t _{CTP/2}		t _{CTP/2}		t _{CTP/2}	ns
t _{PC_f}	4-26	All Port B, C Outputs Floating (Notes 2, 4)	After R.E., CTTL	0	t _{CTP/2} + 15	0	t _{CTP/2} + 14	0	t _{CTP/2} + 13	ns

Note 1: When configured as MWIRE signal, MWSO is changed on the first CTTL R.E. following the relevant MWSK edge.

Note 2: SNH, PCLK, UTXD, UREN, MWSO, PIO0-1, SBYPS.

Note 3: Float according to FLDA input.

Note 4: The parameters related to the "floating/not floating" conditions are guaranteed by characterization. Due to tester conditions, these parameters are not 100% tested.

4.0 Device Specifications (Continued)

4.6.2 Timing Tables (Continued)

4.6.2.2 Input Signal Requirements

Symbol	Figure	Description	Reference/ Condition	NS32FX200-15		NS32FX200-20		NS32FX200-25		Units
				Min	Max	Min	Max	Min	Max	
t _{CTp}	4-8	CTTL Clock Period	R.E. CTTL to Next R.E. CTTL	66	544	50	544	40	544	ns
t _{CTh}	4-8	CTTL High Time	At 2.0V (Both Edges)	t _{CTp/2} – 6 ns		t _{CTp/2} – 5 ns		t _{CTp/2} – 5 ns		
t _{CTl}	4-8	CTTL Low Time	At 0.8V (Both Edges)	t _{CTp/2} – 6 ns		t _{CTp/2} – 5 ns		t _{CTp/2} – 4 ns		
t _{CTr}	4-8	CTTL Rise Time (Note 1)	0.8V to 2.0V on R.E., CTTL		6		5		4	ns
t _{CTf}	4-8	CTTL Fall Time (Note 1)	2.0V to 0.8V on F.E., CTTL		6		5		4	ns
t _{XFP}	4-8	FOSCI Clock Period	R.E. FOSCI to Next R.E. FOSCI	33	34	25	34	20	34	ns
t _{XFh}	4-8	FOSCI High Time	At 3.8V (Both Edges)	t _{XFP/2} – 5 ns		t _{XFP/2} – 4 ns		t _{XFP/2} – 3 ns		
t _{XFl}	4-8	FOSCI Low Time	At 1.0V (Both Edges)	t _{XFP/2} – 5 ns		t _{XFP/2} – 4 ns		t _{XFP/2} – 3 ns		
t _{XSp}	4-8	SOSCI Clock Period (Note 2)	R.E. SOSCI to Next R.E. SOSCI	32.768 kHz or 455 kHz						
t _{XSh}	4-8	SOSCI High Time	At 3.8V (Both Edges)	t _{XSp/2} – 5 ns		t _{XSp/2} – 4 ns		t _{XSp/2} – 3 ns		
t _{XSl}	4-8	SOSCI Low Time	At 1.0V (Both Edges)	t _{XSp/2} – 5 ns		t _{XSp/2} – 4 ns		t _{XSp/2} – 3 ns		
t _{CTCd}	4-8	CCLK to CTTL Delay	3.8V on R.E., CTTL to R.E., CCLK		35		35		30	ns
t _{ALs}	4-9	AD0–AD15 Setup	Before R.E., CTTL T2	51		36		27		ns
t _{ALh}	4-9	AD0–AD15 Hold	After R.E., CTTL T2	0		0		0		ns
t _{AHs}	4-9	A16–A23 Setup	Before R.E., CTTL T2	51		36		27		ns
t _{AHh}	4-9	A16–A23 Hold	After R.E., CTTL next T1/i	0		0		0		ns
t _{RSTw}	4-22	RST Pulse Width	At 0.8V (both edges), PFAIL = 1	25		25		25		ms

Note 1: Due to tester conditions, this parameter is not 100% tested.

Note 2: Tested at 32.00 kHz only.

4.0 Device Specifications (Continued)

4.6.2 Timing Tables (Continued)

4.6.2.2 Input Signal Requirements (Continued)

Symbol	Figure	Description	Reference/ Condition	NS32FX200-15		NS32FX200-20		NS32FX200-25		Units
				Min	Max	Min	Max	Min	Max	
t _{ADSS}	4-9	$\overline{\text{ADS}}$ Signal Setup	Before R.E., CTTL T2	51		36		27		ns
t _{ADSw}	4-9	$\overline{\text{ADS}}$ Pulse Width	At 0.8V (Both Edges)	20		15		10		ns
t _{Ds}	4-16	Data Setup	Before R.E., CTTL T4	15		14		10		ns
t _{Dh}	4-16	Data Hold	After R.E., CTTL T4	0		0		0		ns
t _{HBEs}	4-9	$\overline{\text{HBE}}$ Signal Setup	Before R.E., CTTL T2	51		36		27		ns
t _{HBEh}	4-9	$\overline{\text{HBE}}$ Signal Hold	After R.E., CTTL next T1/i	0		0		0		ns
t _{DDINs}	4-9	DDIN Signal Setup	Before R.E., CTTL T2	51		36		27		ns
t _{DDINh}	4-9	DDIN Signal Hold	After R.E., CTTL next T1/i	0		0		0		ns
t _{HLDA_s}	4-16	$\overline{\text{HLDA}}$ Signal Setup	Before R.E., CTTL Ti	51		36		27		ns
t _{HLDA_h}	4-16	$\overline{\text{HLDA}}$ Signal Hold	After R.E., CTTL Ti	0		0		0		ns
t _{SDINs}	4-19	SDIN Signal Setup	Before F.E., CTTL	15		14		12		ns
t _{SDINh}	4-19	SDIN Signal Hold	After F.E., CTTL	0		0		0		ns
t _{SVIs}	4-27	SVI Signal Setup (Notes 1, 2)	After L.E., SNH		t _{SCMPRW} – 200 ns		t _{SCMPRW} – 200 ns		t _{SCMPRW} – 200 ns	ns
t _{SVIh}	4-27	SVI Signal Hold	After L.E., Next SNH	0		0		0		ns
t _{SBGs}	4-27	SBG Signal Setup (Notes 1, 2)	After L.E., SNH		t _{SCMPRW} – 200 ns		t _{SCMPRW} – 200 ns		t _{SCMPRW} – 200 ns	ns
t _{SBGh}	4-27	SBG Signal Hold	After L.E., Next SNH	0		0		0		ns
t _{PFAILs}	4-22	$\overline{\text{PFAIL}}$ Signal Setup	Before R.E., CTTL	15		14		13		ns
t _{PFAILh}	4-22	$\overline{\text{PFAIL}}$ Signal Hold	After R.E., CTTL	0		0		0		ns
t _{INTs}	4-18	INT0–3 Signal Setup	Before R.E., CTTL	15		14		13		ns
t _{INTh}	4-18	INT0–3 Signal Hold	After R.E., CTTL	0		0		0		ns

Note 1: $t_{\text{SCMPRW}} = (\text{SCMPRW} + 1) * t_{\text{CTP}}$ while SCMPRW is the programmed value in SCMPRW register. The current tolerance is 8 μA .

Note 2: The internal analog reset width, as programmed in the SCMPRW register, should be more than 200 ns. The analog reset should be terminated at least 300 ns before the next SNH leading edge.

4.0 Device Specifications (Continued)

4.6.2 Timing Tables (Continued)

4.6.2.2 Input Signal Requirements (Continued)

Symbol	Figure	Description	Reference/ Condition	NS32FX200-15		NS32FX200-20		NS32FX200-25		Units
				Min	Max	Min	Max	Min	Max	
t _{URXD_s}	4-24	URXD Signal Setup	Before R.E., CTTL	15		14		13		ns
t _{URXD_h}	4-24	URXD Signal Hold	After R.E., CTTL	0		0		0		ns
t _{UTEN_s}	4-24	UTEN Signal Setup	Before R.E., CTTL	t _{CTP/2} + 15		t _{CTP/2} + 14		t _{CTP/2} + 13		ns
t _{UTEN_h}	4-24	UTEN Signal Hold	After R.E., CTTL	t _{CTP/2}		t _{CTP/2}		t _{CTP/2}		ns
t _{DMRQ_s}	4-16	DMRQ0–3 Signal Setup	Before R.E., CTTL	30		29		28		ns
t _{DMRQ_h}	4-16	DMRQ0–3 Signal Hold	After R.E., CTTL	0		0		0		ns
t _{MWSI_s}	4-25	MWSI Signal Setup (Note 1)	Before R.E., CTTL	t _{CTP/2} + 15		t _{CTP/2} + 14		t _{CTP/2} + 13		ns
t _{MWSI_h}	4-25	MWSI Signal Hold	After R.E., CTTL	t _{CTP/2}		t _{CTP/2}		t _{CTP/2}		ns
t _{SBYPS_s}	4-23	SBYPS Signal Setup	Before R.E., CTTL	30		29		28		ns
t _{SBYPS_h}	4-23	SBYPS Signal Hold	After R.E., CTTL	0		0		0		ns
t _{pAs}	4-26	Port A Signal Setup	Before R.E., CTTL	t _{CTP/2} + 15		t _{CTP/2} + 14		t _{CTP/2} + 13		ns
t _{pAh}	4-26	Port A Signal Hold	After R.E., CTTL	t _{CTP/2}		t _{CTP/2}		t _{CTP/2}		ns
t _{pCs}	4-26	Port C Signal Setup (Note 2)	Before R.E., CTTL	t _{CTP/2} + 15		t _{CTP/2} + 14		t _{CTP/2} + 13		ns
t _{pCh}	4-26	Port C Signal Hold	After R.E., CTTL	t _{CTP/2}		t _{CTP/2}		t _{CTP/2}		ns

Note 1: When configured as MWIRE signal, MWSI is sampled on the first CTTL R.E. following the MWSK F.E.

Note 2: Includes all port C pins, when configured as general purpose pins.

4.0 Device Specifications (Continued)

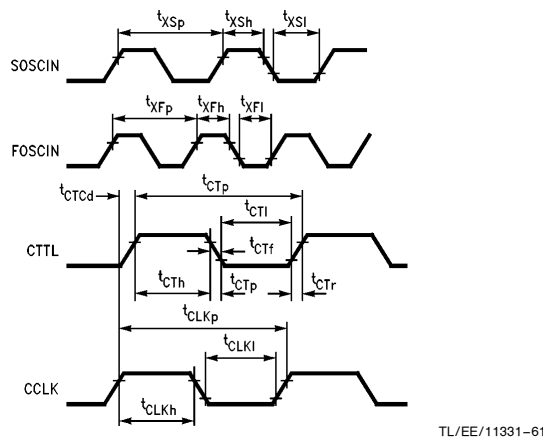

FIGURE 4-8. Clock Waveforms

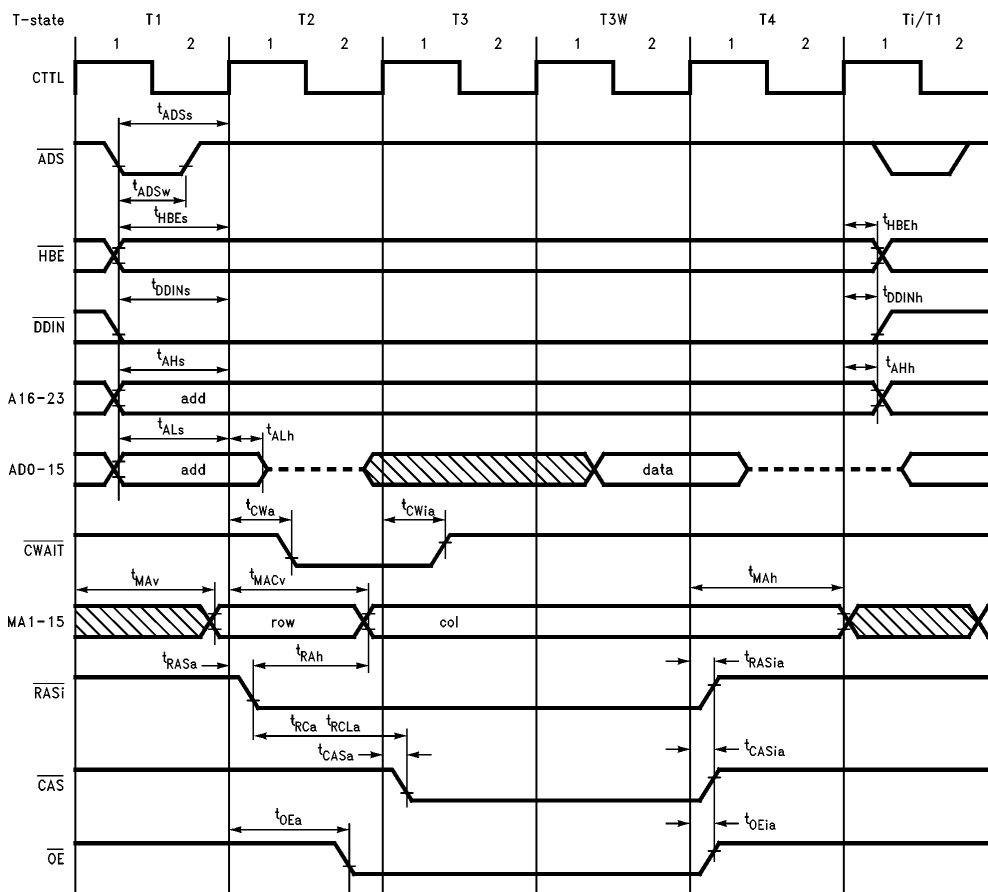

FIGURE 4-9. DRAM Read Bus Cycle

4.0 Device Specifications (Continued)

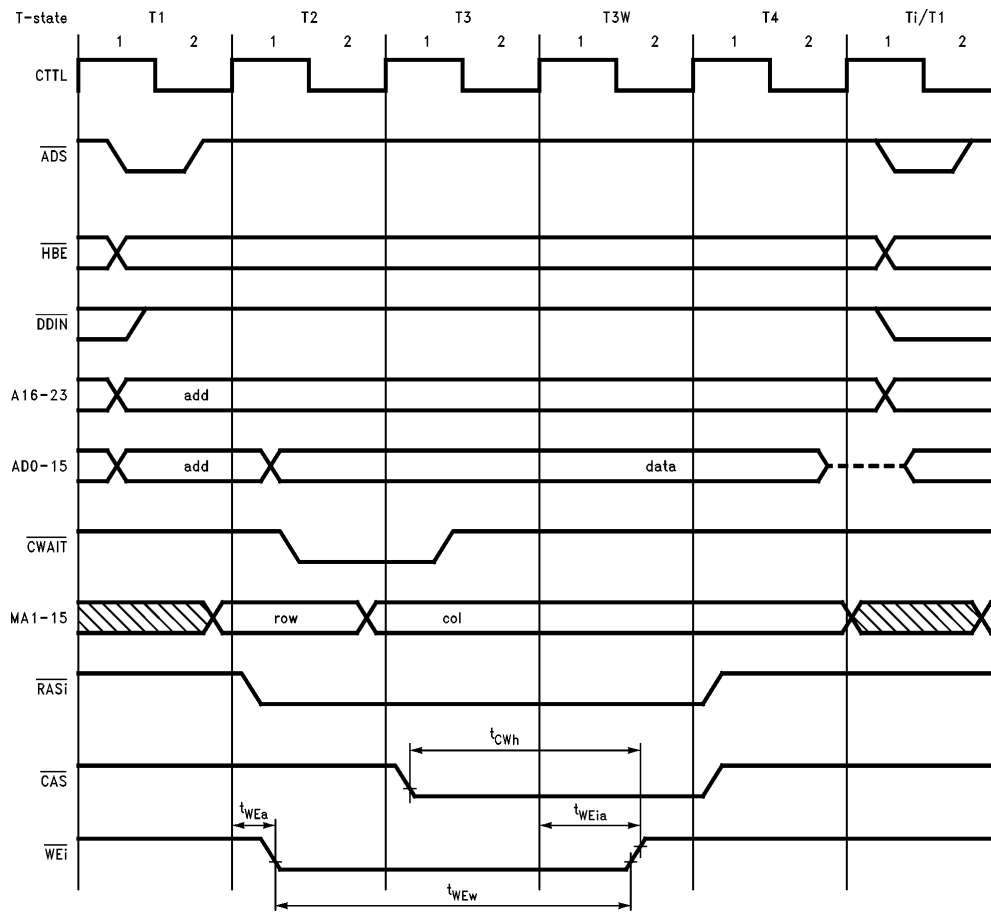

FIGURE 4-10. DRAM Write Bus Cycle

TL/EE/11331-63

4.0 Device Specifications (Continued)

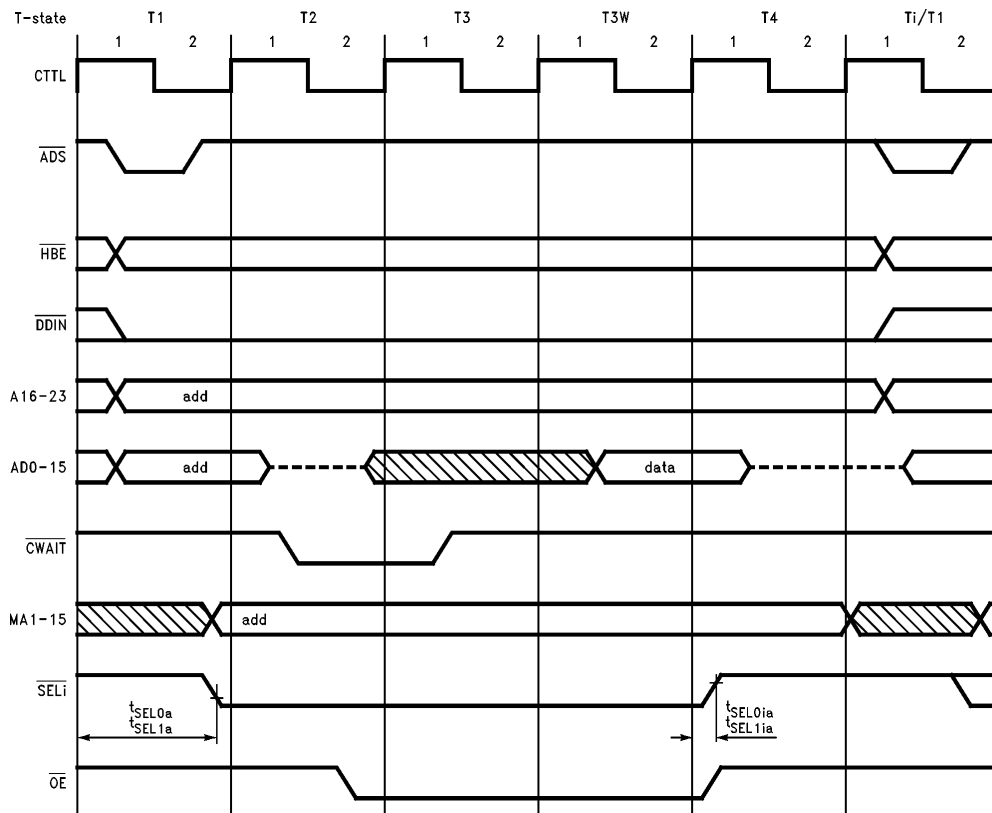

FIGURE 4-11. ROM/SRAM Read Bus Cycle

TL/EE/11331-64

4.0 Device Specifications (Continued)

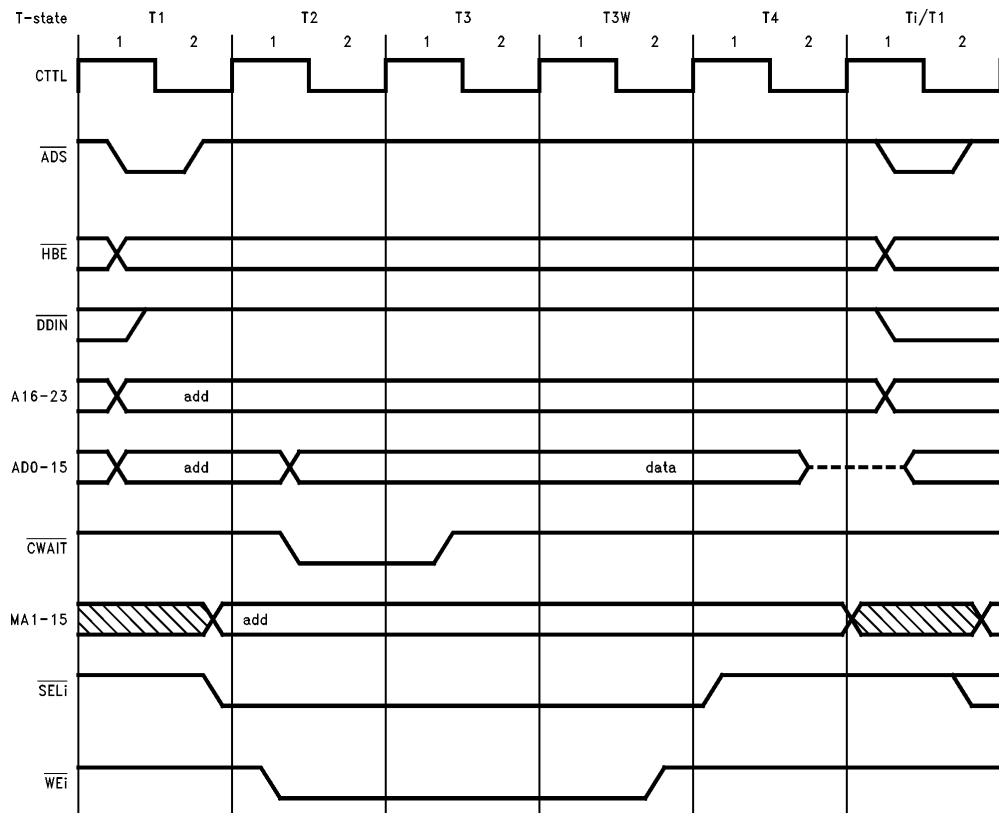

FIGURE 4-12. ROM/SRAM Write Bus Cycle (One Wait State)

TL/EE/11331-65

4.0 Device Specifications (Continued)

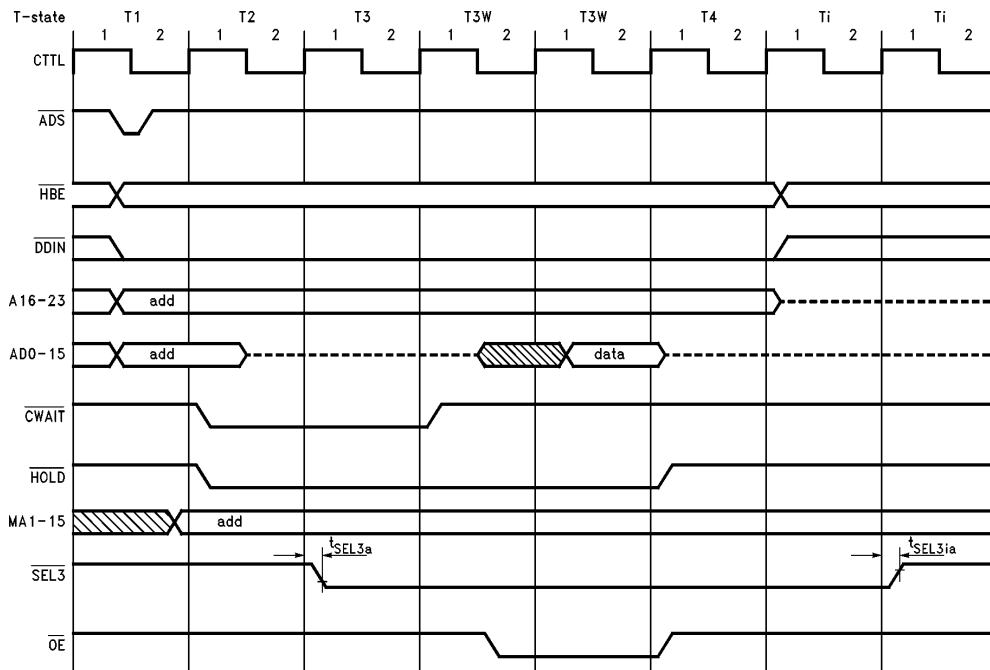

FIGURE 4-13. I/O Read Bus Cycle

TL/EE/11331-66

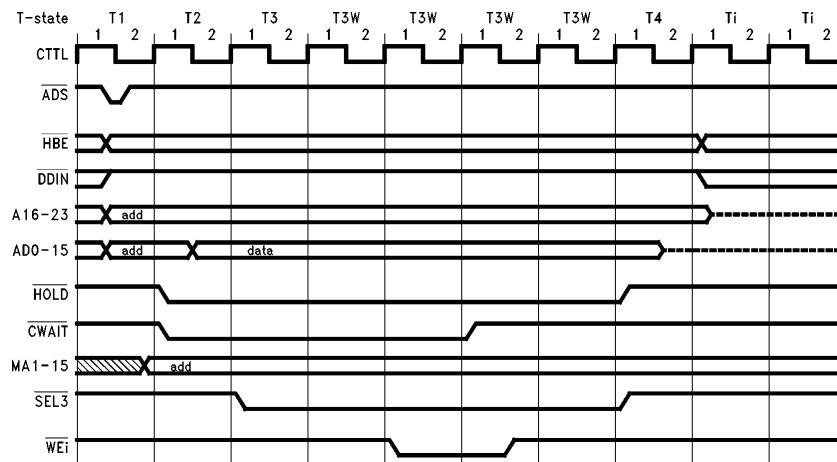
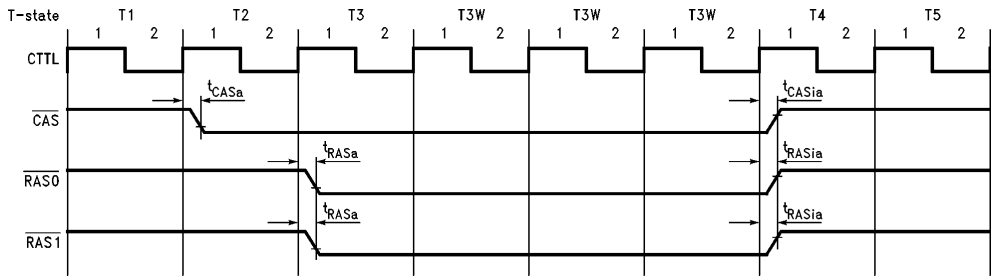

FIGURE 4-14. I/O Write Bus Cycle

TL/EE/11331-67

4.0 Device Specifications (Continued)



TL/EE/11331-68

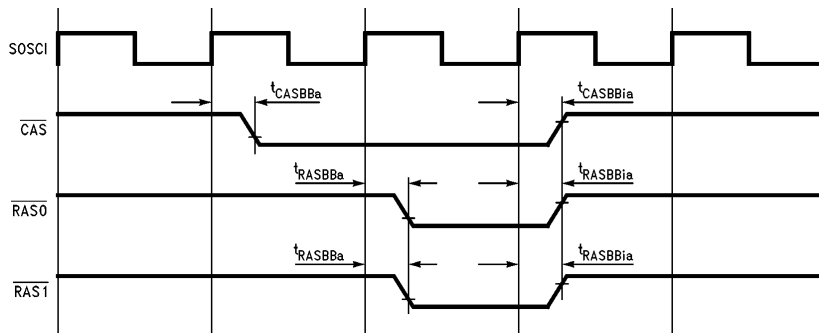

TL/EE/11331-69

FIGURE 4-15. DRAM Refresh Bus Cycles

4.0 Device Specifications (Continued)

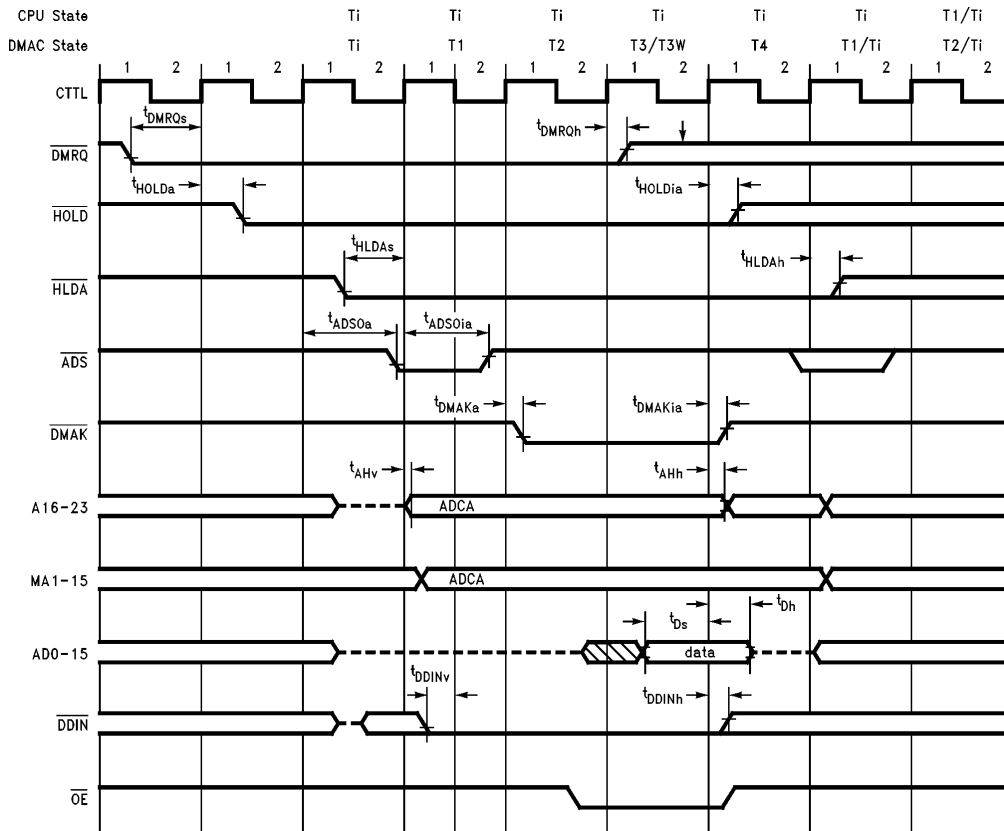

TL/EE/11331-70

FIGURE 4-16. DMA Read Transaction (DIR = 0)

Note: t_{DS} and t_{DH} are irrelevant in Fly-By mode when the implied I/O is external, i.e., when the DMA channel is used as an external channel.

4.0 Device Specifications (Continued)

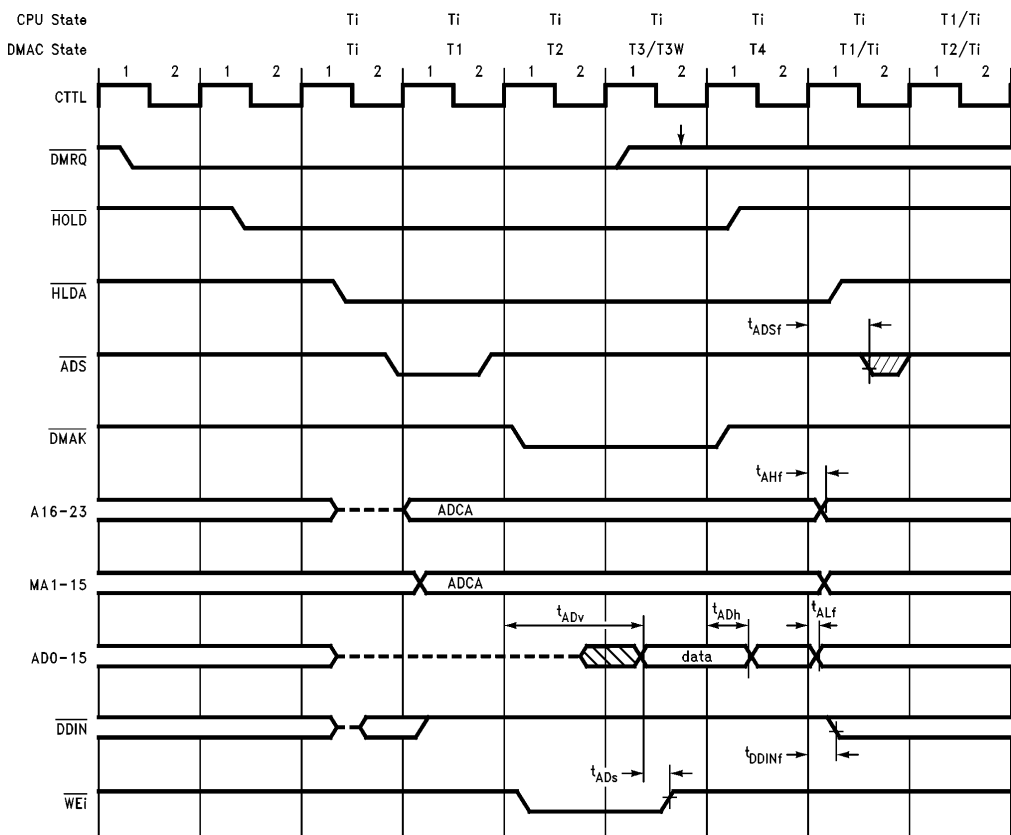

TL/EE/11331-71

Note: CPU drives \overline{ADS} , A16-23, \overline{DDIN} when \overline{HLDA} becomes inactive.

FIGURE 4-17. DMA Write Transaction (DIR = 1)

Note: t_{ADv} , t_{ADh} and t_{ADs} irrelevant in Fly-By mode when the implied I/O is external, i.e., when the DMA channel is used as an external channel.

4.0 Device Specifications (Continued)

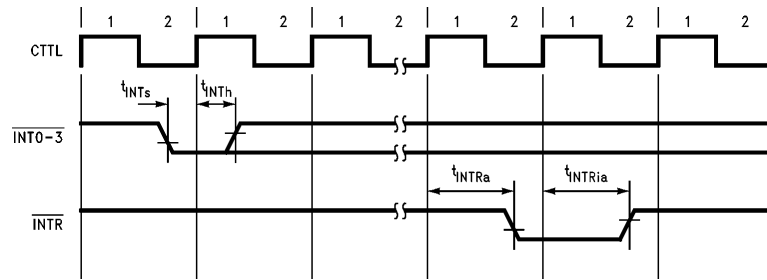

FIGURE 4-18. Interrupt Signals Timing

TL/EE/11331-72

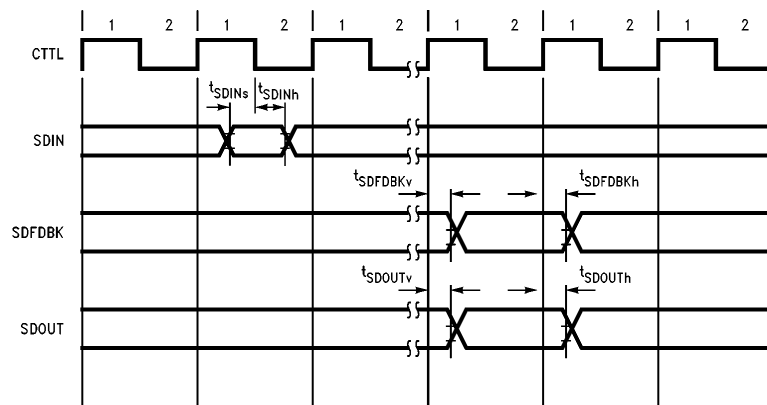

FIGURE 4-19. Sigma-Delta Signals Timing

TL/EE/11331-73

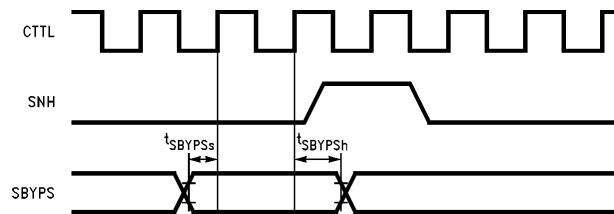

FIGURE 4-20. SBYPs Input Signal Timing

TL/EE/11331-74

4.0 Device Specifications (Continued)

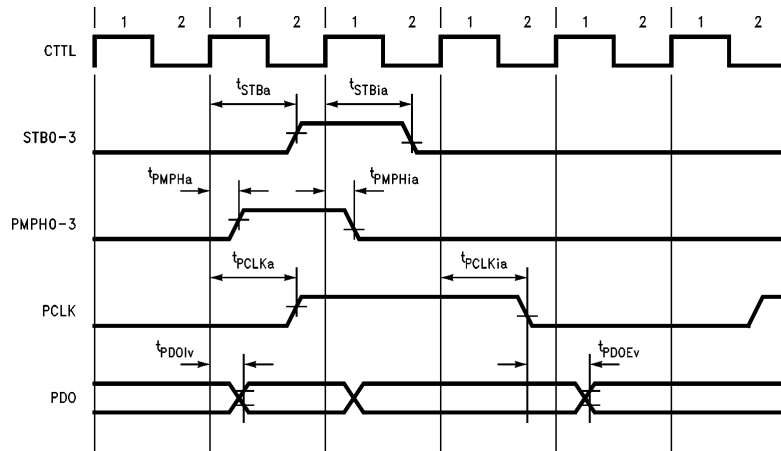

FIGURE 4-21. Printer Signals Timing

TL/EE/11331-75

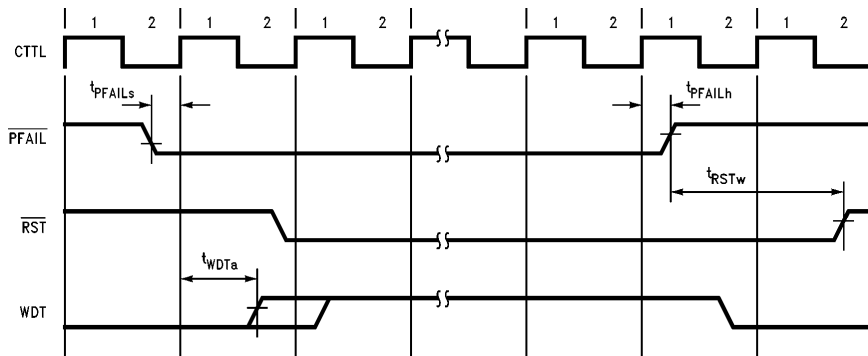
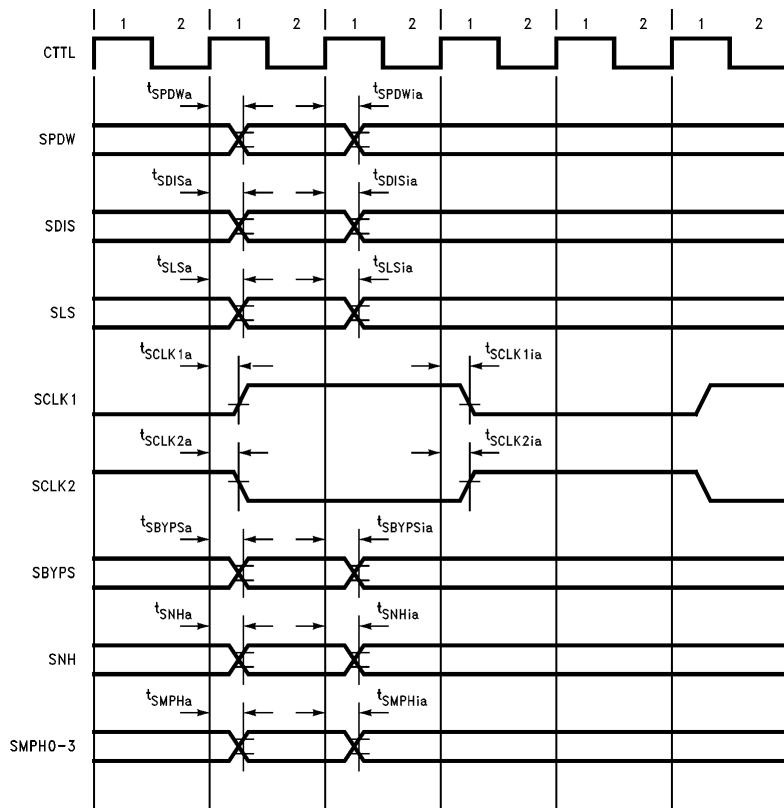

FIGURE 4-22. Reset Signals Timing

TL/EE/11331-76

4.0 Device Specifications (Continued)



TL/EE/11331-77

Note: For convenience, all the above signals are shown on the same diagram. The diagram shows the relationship between each signal and CTTL only. There is no significance in the relationships between individual signals.

See Figures 2-7 and 2-8 (in Scanner Block 2.4.2) for detailed relationships between these signals.

FIGURE 4-23. Scanner Signals Timing

4.0 Device Specifications (Continued)

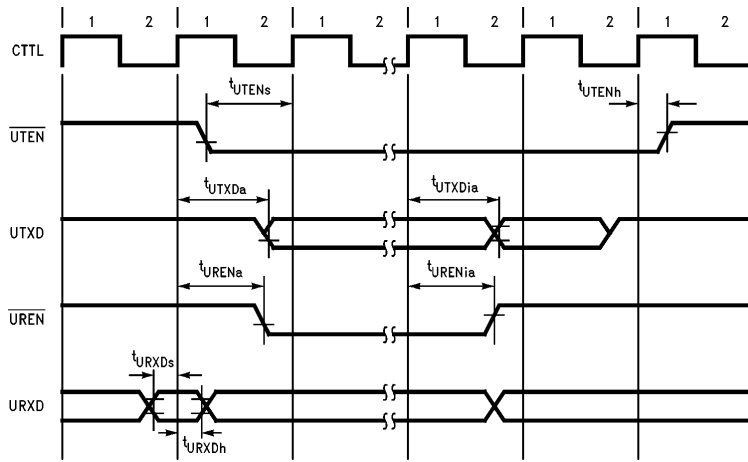

FIGURE 4-24. UART Signals Timing

TL/EE/11331-78

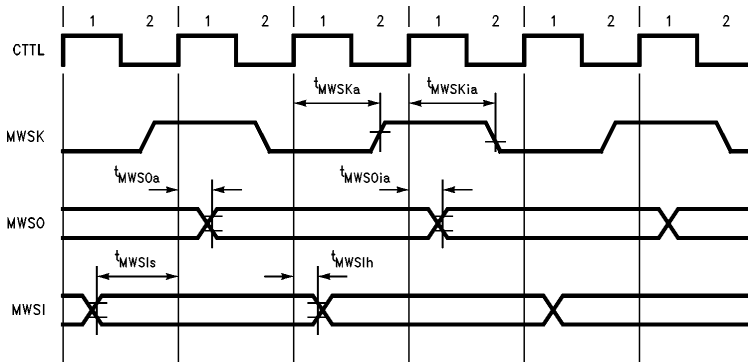
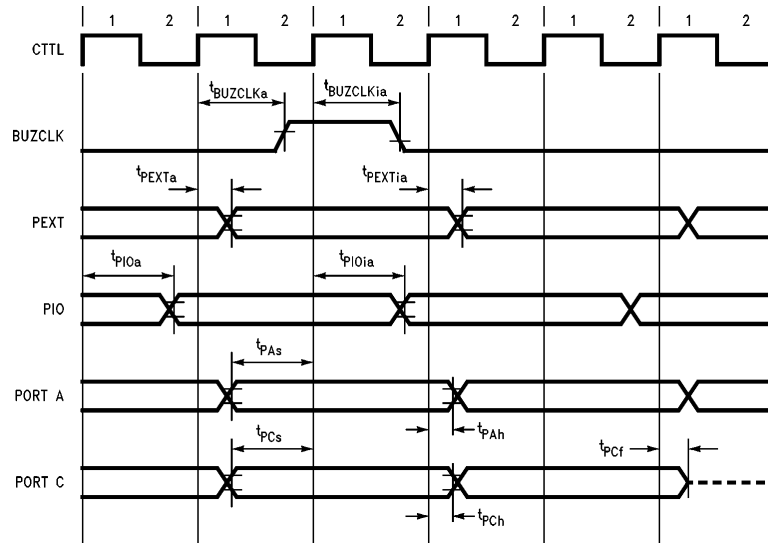

FIGURE 4-25. Mwire Signals Timing

TL/EE/11331-79

4.0 Device Specifications (Continued)



TL/EE/11331-80

FIGURE 4-26. Ports Signals Timing

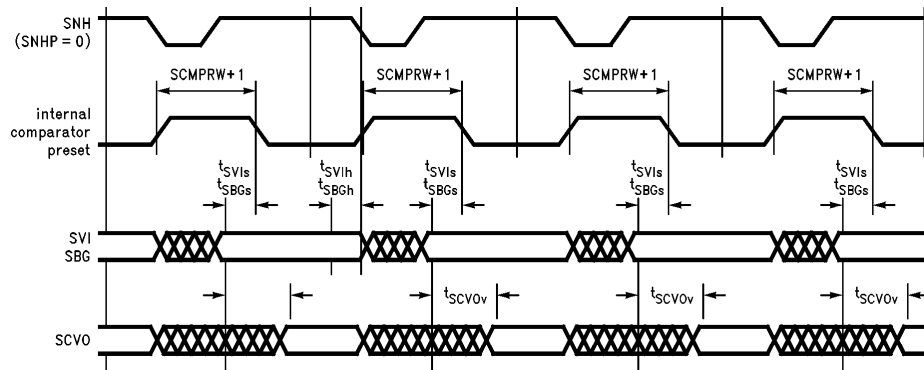

TL/EE/11331-81

FIGURE 4-27. Analog Signals Timing

Appendix A: Codec Transmission Performance

The Sigma Delta Codec transmission performance of a typical complete system, including DAA, is according to the following test conditions:

The measurement analog circuit is according to *Figure 2-5*. The measurements are performed on the line with 600Ω termination. The transmit and receive gains are programmed for amplification/attenuation of 0 dB. The Echo-

canceling filter is disabled. The transmission absolute accuracy is measured after auto-calibration of the measuring circuit.

Electrical test conditions:

$$T_A = 25^\circ\text{C}$$

$$\text{Digital Supplies } V_{CCD} = 5V \pm 10\%, \text{ GND} = 0V.$$

$$\text{Analog Supplies } V_{CCA} = \pm 5V \pm 5\%,$$

$$V_{EE} = \pm 12V \pm 10\%.$$

TABLE A-1. Transmitter Performance

Parameter	Conditions	Min	Typ	Max	Unit
Tx Peak Level		-2.1		+2.1	V
Maximum Level	tx +3.14 dbmo		+6.00		dbm
Transmit Gain Absolute Accuracy		-0.5		+0.5	db
Transmit Gain Variation with Frequency	300 Hz	-0.5		+0.5	db
	500 Hz-3000 Hz	-0.3		+0.3	db
	3400 Hz	-2.0		+0.0	db
	3900 Hz			-12	db
Transmit Noise Psofometric Weighted			-88	-85	dbmPo
Spurious Out of Band	5.1 kHz-7.2 kHz			-45	db
	7.2 kHz-20 kHz			-60	db
	20 kHz-100 kHz			-65	db
Signal to Total Distortion Half Channel, Sine Method (without transformer distortion)	Level = 3 dbmo	40			dbP
	-10 dbmo	67	69		dbP
	(-18)-0 dbmo	60			dbP
	(-38)-(-18)dbmo	40			dbP
	-45 dbmo	32			dbP

Appendix A: Codec Transmission Performance (Continued)

TABLE A-2. Receiver Performance

Parameter	Conditions	Min	Typ	Max	Units
Receive Gain Absolute Accuracy		-0.5		+0.5	db
Receive Gain Variation with Frequency	60 Hz			-14	db
	300 Hz	-1.5		+0.3	db
	500 Hz-3000 Hz	-0.4		+0.3	db
	3400 Hz	-1.5		+0.0	db
	3900 Hz			-12	db
	16 kHz			-35	db
Receive Noise Psofometric Weighted			-80	-76	dbmPo
Signal to Total Distortion Half Channel, Sine Method (without transformer distortion)	Total Gain = 0 db Input Level = 3 dbmo	50			dbP
	0 dbmo		75		dbP
	(-8)-0 dbmo	70	72		dbP
	(-28)-(-8) dbmo	50			dbP
	(-43)-(-28) dbmo	35			dbP
Signal to Total Distortion Half Channel, Sine Method (without transformer distortion)	Total Gain = 9 dB Input Level = -6 dbmo	50			dbP
	-9 dbmo		75		dbP
	(-17)-(-9) dbmo	70	72		dbP
	(-37)-(-17) dbmo	50			dbP
	(-52)-(-37) dbmo	35			dbP

**NS32FX100-15/NS32FX100-20/NS32FX100-20/NS32FV100-25/
NS32FX200-20/NS32FX200-25 System Controller**

Physical Dimensions inches (millimeters)

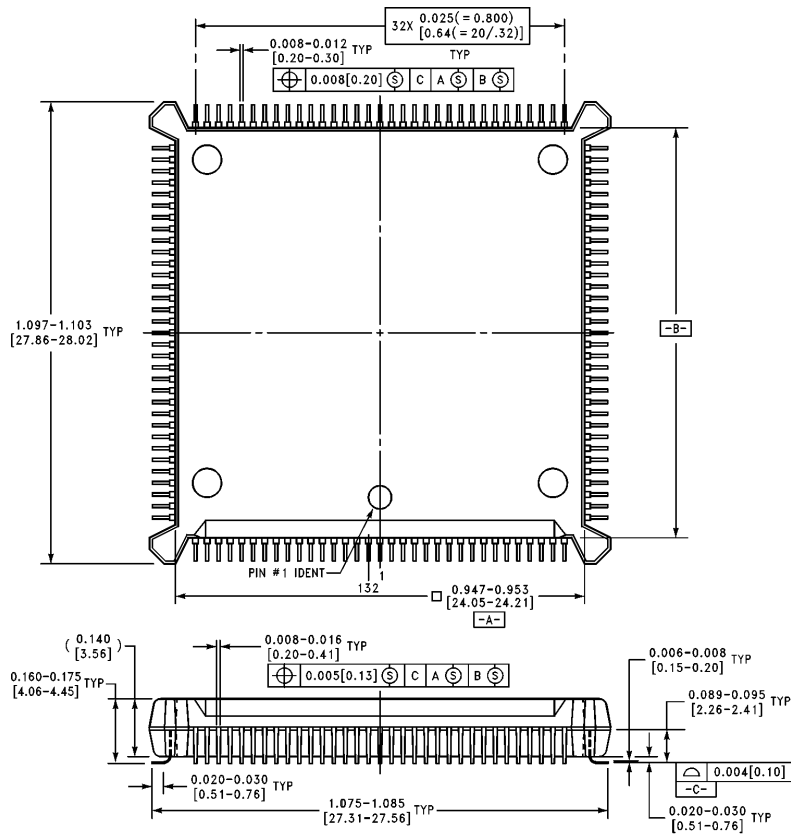

VF132A (REV D)

Plastic Chip Carrier (VF)
Order Number NS32FX200VF, NS32FX100VF or NS32FV100FV
NS Package Number VF132A

LIFE SUPPORT POLICY

NATIONAL'S PRODUCTS ARE NOT AUTHORIZED FOR USE AS CRITICAL COMPONENTS IN LIFE SUPPORT DEVICES OR SYSTEMS WITHOUT THE EXPRESS WRITTEN APPROVAL OF THE PRESIDENT OF NATIONAL SEMICONDUCTOR CORPORATION. As used herein:

1. Life support devices or systems are devices or systems which, (a) are intended for surgical implant into the body, or (b) support or sustain life, and whose failure to perform, when properly used in accordance with instructions for use provided in the labeling, can be reasonably expected to result in a significant injury to the user.
2. A critical component is any component of a life support device or system whose failure to perform can be reasonably expected to cause the failure of the life support device or system, or to affect its safety or effectiveness.



National Semiconductor Corporation
 1111 West Bardin Road
 Arlington, TX 76017
 Tel: 1(800) 272-9959
 Fax: 1(800) 737-7018

National Semiconductor Europe
 Fax: (+49) 0-180-530 85 86
 Email: onjwge@tevm2.nsc.com
 Deutsch Tel: (+49) 0-180-530 85 85
 English Tel: (+49) 0-180-532 78 32
 Français Tel: (+49) 0-180-532 93 58
 Italiano Tel: (+49) 0-180-534 16 80

National Semiconductor Hong Kong Ltd.
 19th Floor, Straight Block,
 Ocean Centre, 5 Canton Rd.
 Tsimshatsui, Kowloon
 Hong Kong
 Tel: (852) 2737-1600
 Fax: (852) 2736-9960

National Semiconductor Japan Ltd.
 Tel: 81-043-299-2309
 Fax: 81-043-299-2408

National does not assume any responsibility for use of any circuitry described, no circuit patent licenses are implied and National reserves the right at any time without notice to change said circuitry and specifications.