

### Features

- Precise detection of call progress tones
- Linear (analog) input
- Digital (CMOS compatible), tri-state outputs
- 22-pin DIP and 20-pin SOIC
- Single supply 3 to 5 volt (low power CMOS)
- Inexpensive 3.58 MHz crystal time base
- Wide dynamic range (30 dB)
- Lower power consumption (power-down mode)
- 425 Hz detection

### Applications

- Automatic dialers
- Dialing modems
- Traffic
- Measurement equipment
- Test equipment
- Service evaluation
- Billing systems

### Description

The M-982-02 is an integrated circuit precise tone detector for special-purpose use in automatic following of switched telephone calls. The circuit uses low-power CMOS techniques to provide the complete filtering and control required for this function. The basic timing of the M-982-02 is designed to permit operation with almost any progress tone system. The use of integrated circuit techniques allows the M-982-02 to pack the five filters for call progress following into a single 22-pin DIP or 20-pin SOIC. A 3.58 MHz crystal-controlled time base guarantees accuracy and repeatability.

The M-982-02 is an enhanced drop-in replacement for the M-982-01. It has a wider operating voltage range (down to 3V). It has lower power consumption under normal operating conditions. In addition, a power-down (PD) feature is provided to further reduce power consumption when inactive. It includes a 425 Hz detector to support common international call progress requirement.

### Pin Diagram

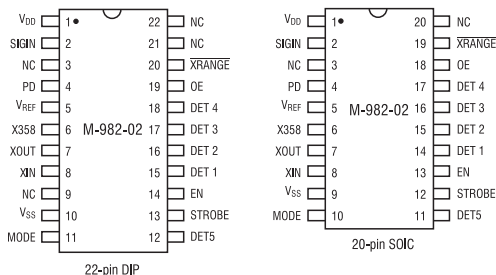

### Ordering Information

Part #	Description
M-982-02P	22-pin plastic DIP
M-982-02S	20-pin plastic SOIC
M-982-02T	20-pin plastic SOIC, Tape and Reel

### Block Diagram

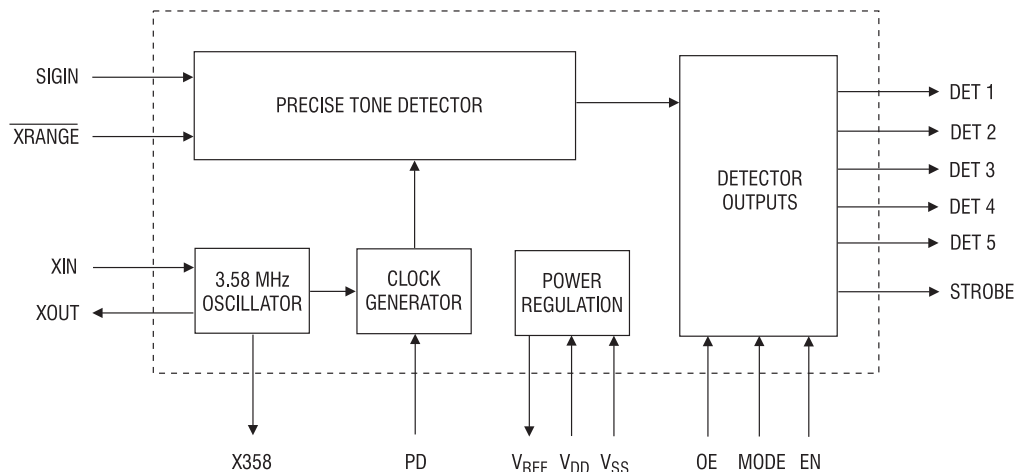

**M-982-02****Absolute Maximum Ratings**

Storage Temperature	-40 to 150°C
Operating Ambient Temperature	-40 to 85°C
V <sub>DD</sub>	7V
Input Voltage on SIGIN	V <sub>SS</sub> - 6.5 to V <sub>DD</sub> + 0.3V
Input Voltages (except SIGIN)	V <sub>SS</sub> - 0.3 to V <sub>DD</sub> + 0.3 V
Lead Soldering Temperature	260° C for 5 seconds

Note: Exceeding these ratings may permanently damage the M-982-02.

Absolute Maximum Ratings are stress ratings. Stresses in excess of these ratings can cause permanent damage to the device. Functional operation of the device at these or any other conditions beyond those indicated in the operational sections of this data sheet is not implied. Exposure of the device to the absolute maximum ratings for an extended period may degrade the device and effect its reliability.

**Specifications**

Parameter		Conditions	Min	Max	Units	Notes	
Operating Conditions	V <sub>DD</sub>	-	2.7	5.5	V	-	
	Power supply noise	0.1 - 5 kHz	-	20	mV p-p	-	
Power	Current drain (I <sub>DD</sub> )	V <sub>REF</sub> open	-	15	mA	-	
V <sub>REF</sub>	V <sub>REF</sub>	-	48% of V <sub>DD</sub>	52% of V <sub>DD</sub>	V	-	
	Impedance	-	3.25	8.25	kW	-	
Signal Detection	Frequency range	in-band signal	-1	+1	% of f <sub>0</sub>	1	
	Level: V <sub>DD</sub> = 5.0V	XRANGE = open	-30 (24.5 mV)	0 (775 mV)	dBm	-	
		XRANGE = V <sub>SS</sub>	-40 (7.8 mV)	-10 (245 mV)	dBm	-	
	Level: V <sub>DD</sub> = 3.0V	XRANGE = open	-33 (17.4 mV)	-3 (549 mV)	dBm	-	
		XRANGE = V <sub>SS</sub>	-43 (5.5 mV)	-13 (173.5 mV)	dBm	-	
	Duration (t <sub>DD</sub> )	-	200	-	ms	-	
	Bridge time (t <sub>BB</sub> )	-	-	20	ms	-	
	Level skew between adjacent inband signals	for detection of both	-	6	dB	-	
	High level to low level signal for detection of both (t <sub>HL</sub> )	high = 0 dBm (775 mV) low = -30 dBm (24.5 mV)	1	-	s	-	
	Time to output (t <sub>DO</sub> )	SIGIN ≈ -24 dBm	-	-	200	ms	-
SIGIN < -24 dBm		-	-	240	ms	-	
Time from DET n to STROBE (t <sub>DS</sub> )	-	-	-	10	ms	-	
Signal Rejection	Frequency range	-	-6	-6	% of f <sub>0</sub>	1	
	Level: V <sub>DD</sub> = 5.0V	XRANGE = open	-	-50(2.5 mV)	dBm	-	
		XRANGE = V <sub>SS</sub>	-	-60 (0.8 mV)	dBm	-	
	Level: V <sub>DD</sub> = 3.0V	XRANGE = open	-	-53 (1.7 mV)	dBm	-	
		XRANGE = V <sub>SS</sub>	-	-63 (.6 mV)	dBm	-	
	Interval duration (t <sub>ID</sub> )	-	160	-	ms	-	
Time to output (T <sub>IO</sub> )	-	-	-	200	ms	-	
Outputs	DET n, STROBE pins	V <sub>OL</sub>	I <sub>SINK</sub> = -1mA	-	0.5	V	-
		V <sub>OH</sub>	I <sub>SOURCE</sub> = 1mA	V <sub>DD</sub> - 0.5	-	V	-
	DET n pins	I <sub>OZ</sub>	V <sub>O</sub> = V <sub>DD</sub> , V <sub>SS</sub>	-	-	1	μA
Inputs	EN, OE, XRANGE, MODE, PD pins	VIL	-	-	0.5	V	-
		VIH	VDD = 5V	VDD - 2.0	-	V	-
			VDD = 2.7V	VDD - 0.5	-	V	-
	Pull-up and Pull-down currents	MODE = VSS	VDD = 5V	12.5	50	μA	-
			VDD = 2.7V	4	20	μA	-
		/Xrange = VSS	-	2	6	μA	-
PD = VDD	-	4	10	μA	-		

**Specifications (continued)**

Parameter		Conditions	Min	Max	Units	Notes
	SIGIN pin	Voltage range	-	-6.5	VDD	V
		Input impedance	f=500 Hz	80	-	kΩ
		Input spectrum	-	-	28	kHz
Clock	External clock connected to XIN pin	VIL	XOUT open	-	0.2	V
		VIH	XOUT open	VDD-0.2	-	V
		Duty cycle	XOUT open	40	60	%
	XIN, XOUT with crystal Cap active	Capacitance	-	-	10	pF
		Internal resistance	-	20	-	MW
		Power up (TPU)	PD hi to lo	-	30	ms
	X358 pin	VOL	CL = 20 pF, ISINK = -1mA	-	0.2	V
		VOH	CL = 20 pF, ISOURCE =1mA	VDD - 0.2	-	V
		Duty cycle	CL = 20 pF	40	60	%
Tri-state	tEN,(High Z to Low Z)	CL = 50 pF,	-	250	ns	
Operation	tDE,(Low Z to High Z)	RL = 100 kW	-	250	ns	

Unless otherwise noted,  $V_{DD} - V_{SS} = 5V$ ,  $T_a = 25^\circ C$ , PD at logical low state, and XRANGE at a logical high state. Power levels are in dBm referenced to 600 ohm. DC voltages are referenced to  $V_{SS}$ .

**Notes:**

1. Per tone.

**Pin Functions**

Pin	Function
DET 1	Active high tri-state output, detect for 350 Hz.
DET 2	Active high tri-state output, detect for 400/620 Hz. (See Note.)
DET 3	Active high tri-state output, detect for 440 Hz.
DET 4	Active high tri-state output, detect for 480 Hz.
DET 5	Active high tri-state output, detect for 425 Hz.
EN	Active high enabled, when low drives STROBE low.
OE	Active high input. When low tri-state DET n pins.
SIGIN	Analog signal input (internally capacitive coupled).
STROBE	Active high output, indicates valid DET n.
$V_{DD}$	Most positive power supply input pin.
$V_{REF}$	Internally generated mid-power supply voltage (output).
$V_{SS}$	Most negative power supply input pin.
X358	Buffered oscillator output (3.58 MHz).
XIN	Crystal oscillator or digital clock input.
XOUT	Crystal oscillator output. Used only with a crystal. Use X358 when clock output signal is required.
$\overline{XRANGE}$	Active low input. Adds 10 dB of gain to input stage.
MODE	Compatibility selection. Connection to $V_{SS}$ selects 400 Hz detection. (M-981-02 emulation.) Connection to $V_{DD}$ or no connection selects 620 Hz detection.
PD	Power-down operation, logic high inhibits internal clock. Internal pulldown resistor.

**Note:** This output indicates 400 Hz detect when MODE is connected to  $V_{SS}$  and 620 Hz detect when open, or connected to  $V_{DD}$ .

**Call Progress Tones**

Frequency (HZ)		Use
1	2	
350	440	Dial Tone
400	Off	Special
440	Off	Alert Tone
440	480	Audible Ring
440	620	Pre-empt
480	Off	Bell High Tone
480	620	Reorder (Bell Low)
350	Off	Special
620	Off	Special
941	1209	DTMF "★"
425	Off	European



### Call Progress Tone Detection

Call progress tones are audible tones sent from switching systems to calling parties to show the status of calls. Calling parties can identify the success of a call placed by what is heard after dialing. The type of tone used and its timing vary from system to system, and though intended for human ears these signals can provide valuable information for automated calling systems.

The M-982-02 contains five signal detectors sensitive to the frequencies often used for these progress tones. Electronic equipment monitoring the DET n outputs of the M-982-02 can determine the nature of signals present by measuring their duty cycle. See the Tri-State Timing Diagram on page 5 for a diagram of a circuit that could be used to permit a microcomputer to directly monitor tones on the telephone line. Much of the character of the progress tones is in their duty cycle or cadence (sometimes referred to as interruption rate). This information, coupled with level and frequency indication from the M-982-02, can be used to decide what progress tones have been encountered. For example, dial tones as shown in the Call Progress Tone table on page 3 are usually "on" continuously and

last until the first dial digit is received by the switching system. Line Busy, on the other hand, is turned off and on at a rate of 1 Hz with a 50% duty cycle, or an interruption rate of 60 times per minute (60 IPM). The tones can be distinguished in this way. It should be noted that while such techniques will usually be effective, there are some circumstances in which the M-982-02 cannot be accurately used. Examples include situations where ringback tone may be short or not even encountered. Ringback may be provided at ringing voltage frequency (20 or 30 Hz) with some harmonics and may not fall in the detect range, and speech or other strong noise may obscure tones making cadence measurement difficult.

Standards do exist and should be consulted for your particular application. In North America AT&Ts "Notes on the Network" or EIAs RS-464 PBX standard should be reviewed. In Europe tone plans may vary with locale, in which case the CEPT administration in each country must be consulted. Outside these areas, national PTT organizations can provide information on the systems within their borders.

### Truth Table

Signal Present (fo)	Mode	Det 1	Det 2	Det 3	Det 4	Det 5	Strobe	PD	OE	EN
350 Hz	X	1	X	X	X	X	1	0	1	1
400 Hz (Note)	0	X	1	X	X	X	1	0	1	1
620 Hz (Note)	1/open	X	1	X	X	X	1	0	1	1
440 Hz	X	X	X	1	X	X	1	0	1	1
480 Hz	X	X	X	X	1	X	1	0	1	1
425 Hz	X	X	X	X	X	1	1	0	1	1
Other (no detect)	X	0	0	0	0	0	0	0	1	1
Any	X	0	0	0	0	0	0	1	1	X
Any	X	0	0	0	0	0	0	0	1	0
Any	X	High Impedance					X	0	0	1
Any	X	High Impedance					0	0	0	0
Any	X	High Impedance					X	1	0	X

### Signal Timing

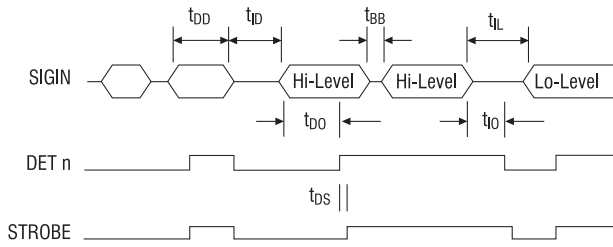

### Tri-State Timing

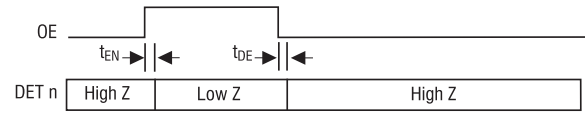

### Power-Down Timing



### Typical Application

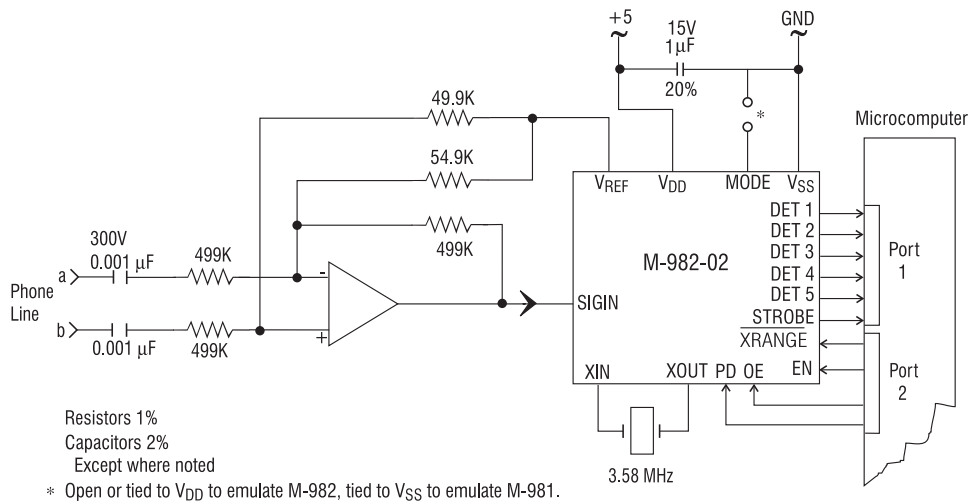



# M-982-02

## Package Dimensions

22-Pin DIP

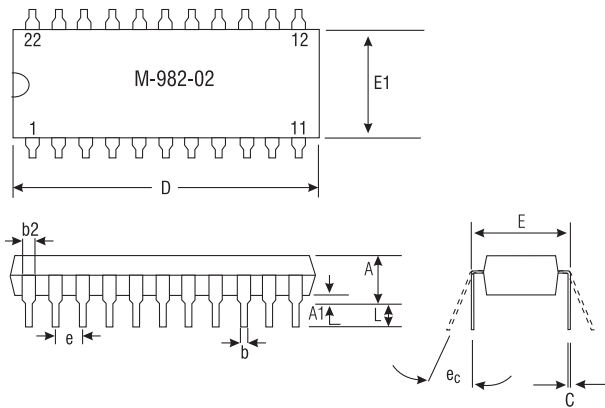

	Tolerances (inches)			Metric Approximation (mm)		
	Min	Nom	Max	Min	Nom	Max
A	-	-	.210	-	-	5.33
A1	.015	-	-	.38	-	-
b	.014	-	.022	.36	-	.56
b2	.045	.060	.065	1.1	1.5	1.7
C	.009	-	.015	.23	-	.38
D	1.065	1.085	1.120	27.1	27.6	28.4
E	.390	.415	.425	9.9	10.5	10.8
E1	.330	.360	.390	8.4	9.1	9.9
e	.100 BSC			2.54 BSC		
ec	0°	15°	15°	0°		15°
L	.115	.130	.160	2.9	3.3	4.1

20-Pin SOIC

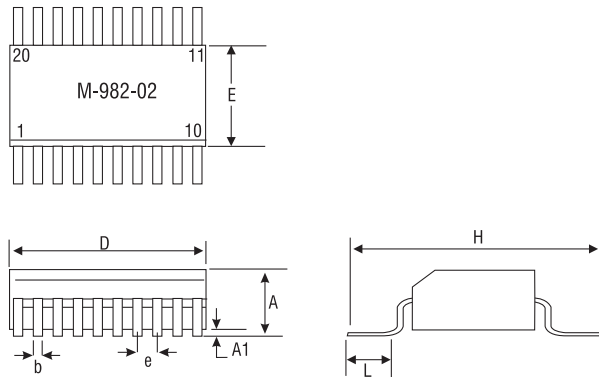

	Tolerances (mm)		SAE approximation (inches)	
	Min	Max	Min	Max
A	2.35	2.65	.0926	.1043
A1	.10	.30	.0040	.0118
b	.33	.51	.013	.020
D	12.60	13.00	.4961	.5118
E	7.4	7.6	.2914	.2992
e	1.27 BSC		.050 BSC	
H	10.00	10.65	.394	.419
L	.40	1.27	.016	.050

Drawing not to scale.  
Does not reflect actual part marking.

Dimensions  
mm  
(inches)

**CLARE LOCATIONS**

Clare Headquarters  
78 Cherry Hill Drive  
Beverly, MA 01915  
Tel: 1-978-524-6700  
Fax: 1-978-524-4900  
Toll Free: 1-800-27-CLARE

Clare Switch Division  
4315 N. Earth City Expressway  
Earth City, MO 63045  
Tel: 1-314-770-1832  
Fax: 1-314-770-1812

Clare Micronix Division  
145 Columbia  
Aliso Viejo, CA 92656-1490  
Tel: 1-949-831-4622  
Fax: 1-949-831-4628

**SALES OFFICES****AMERICAS****Americas Headquarters**

Clare  
78 Cherry Hill Drive  
Beverly, MA 01915  
Tel: 1-978-524-6700  
Fax: 1-978-524-4900  
Toll Free: 1-800-27-CLARE

**Eastern Region**

Clare  
603 Apache Court  
Mahwah, NJ 07430  
Tel: 1-201-236-0101  
Fax: 1-201-236-8685  
Toll Free: 1-800-27-CLARE

**Central Region**

Clare Canada Ltd.  
3425 Harvester Road, Suite 202  
Burlington, Ontario L7N 3N1  
Tel: 1-905-333-9066  
Fax: 1-905-333-1824

**Western Region**

Clare  
1852 West 11th Street, #348  
Tracy, CA 95376  
Tel: 1-209-832-4367  
Fax: 1-209-832-4732  
Toll Free: 1-800-27-CLARE

**Canada**

Clare Canada Ltd.  
3425 Harvester Road, Suite 202  
Burlington, Ontario L7N 3N1  
Tel: 1-905-333-9066  
Fax: 1-905-333-1824

**EUROPE****European Headquarters**

CP Clare nv  
Bampsiaan 17  
B-3500 Hasselt (Belgium)  
Tel: 32-11-300868  
Fax: 32-11-300890

**France**

Clare France Sales  
Lead Rep  
99 route de Versailles  
91160 Champlan  
France  
Tel: 33 1 69 79 93 50  
Fax: 33 1 69 79 93 59

**Germany**

Clare Germany Sales  
ActiveComp Electronic GmbH  
Mitterstrasse 12  
85077 Manching  
Germany  
Tel: 49 8459 3214 10  
Fax: 49 8459 3214 29

**Italy**

C.L.A.R.E.s.a.s.  
Via C. Colombo 10/A  
I-20066 Melzo (Milano)  
Tel: 39-02-95737160  
Fax: 39-02-95738829

**Sweden**

Clare Sales  
Comptronic AB  
Box 167  
S-16329 Spånga  
Tel: 46-862-10370  
Fax: 46-862-10371

**United Kingdom**

Clare UK Sales  
Marco Polo House  
Cook Way  
Bindon Road  
Taunton  
UK-Somerset TA2 6BG  
Tel: 44-1-823 352541  
Fax: 44-1-823 352797

**ASIA/PACIFIC****Asian Headquarters**

Clare  
Room N1016, Chia-Hsin, Bldg II,  
10F, No. 96, Sec. 2  
Chung Shan North Road  
Taipei, Taiwan R.O.C.  
Tel: 886-2-2523-6368  
Fax: 886-2-2523-6369

<http://www.clare.com>

---

*Clare, Inc. makes no representations or warranties with respect to the accuracy or completeness of the contents of this publication and reserves the right to make changes to specifications and product descriptions at any time without notice. Neither circuit patent licenses nor indemnity are expressed or implied. Except as set forth in Clare's Standard Terms and Conditions of Sale, Clare, Inc. assumes no liability whatsoever, and disclaims any express or implied warranty, relating to its products including, but not limited to, the implied warranty of merchantability, fitness for a particular purpose, or infringement of any intellectual property right.*

*The products described in this document are not designed, intended, authorized or warranted for use as components in systems intended for surgical implant into the body, or in other applications intended to support or sustain life, or where malfunction of Clare's product may result in direct physical harm, injury, or death to a person or severe property or environmental damage. Clare, Inc. reserves the right to discontinue or make changes to its products at any time without notice.*

---

Specification: DS-M982-02-R4  
©Copyright 2001, Clare, Inc.  
All rights reserved. Printed in USA.  
7/24/01