

AH5010/AH5011/AH5012 Monolithic Analog Current Switches

General Description

A versatile family of monolithic JFET analog switches economically fulfills a wide variety of multiplexing and analog switching applications.

Even numbered switches may be driven directly from standard 5V logic, whereas the odd numbered switches are intended for applications utilizing 10V or 15V logic. The monolithic construction guarantees tight resistance match and track.

For voltage switching applications see LF13331, LF13332, and LF13333 Analog Switch Family, or the CMOS Analog Switch Family.

Applications

- A/D and D/A converters
- Micropower converters
- Industrial controllers
- Position controllers
- Data acquisition

- Active filters
- Signal multiplexers/demultiplexers
- Multiple channel AGC
- Quad compressors/expanders
- Choppers/demodulators
- Programmable gain amplifiers
- High impedance voltage buffer
- Sample and hold

Features

- Interfaces with standard TTL and CMOS
- "ON" resistance match 2Ω
- Low "ON" resistance 100Ω
- Very low leakage 50 pA
- Large analog signal range ±10V peak
- High switching speed 150 ns
- Excellent isolation between channels 80 dB at 1 kHz

Connection and Schematic Diagrams (All switches shown are for logical "1" input)

Dual-In-Line Package

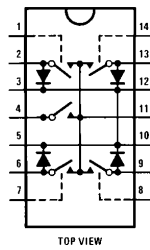

AH5010C MUX Switches
(4-Channel Version Shown)
Order Number AH5010CN

See NS Package Number M14A or N14A

| LOGIC DRIVE | 4 CHANNEL MUX | 4 SPST SWITCHES |
|-------------|---------------|-----------------|
| 5V LOGIC | AH5010C | AH5012C |
| 15V LOGIC | | AH5011C |

Dual-In-Line Package

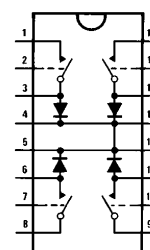

AH5011C and AH5012C SPST Switches
(Quad Version Shown)
Order Number AH5011CN,
AH5012CM or AH5012CN
See NS Package Number M16A or N16A

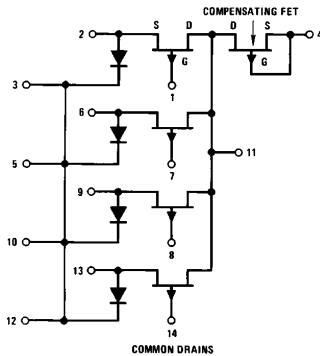

Note: All diode cathodes are internally connected to the substrate.

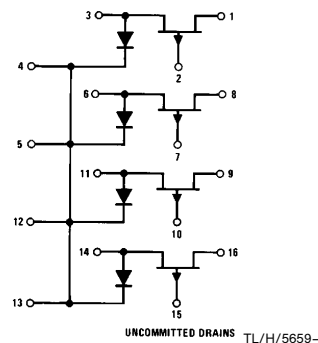

Absolute Maximum Ratings (Note 1)

If Military/Aerospace specified devices are required, please contact the National Semiconductor Sales Office/Distributors for availability and specifications.

| | | | | |
|--------------------------------|----------------------|-------|----------------------------------|-----------------|
| Input Voltage | AH5010/AH5011/AH5012 | 30V | Drain Current | 30 mA |
| Positive Analog Signal Voltage | | 30V | Soldering Information: | |
| Negative Analog Signal Voltage | | -15V | N Package 10 sec | 300°C |
| Diode Current | | 10 mA | SO Package Vapor Phase (60 sec.) | 215°C |
| | | | Infrared (15 sec.) | 220°C |
| | | | Power Dissipation | 500 mW |
| | | | Operating Temperature Range | -25°C to +85°C |
| | | | Storage Temperature Range | -65°C to +150°C |

Electrical Characteristics AH5010 and AH5012 (Notes 2 and 3)

| Symbol | Parameter | Conditions | Typ | Max | Units |
|---------------------|-------------------------|-------------------------------------------------------------------------------|------|------------|----------|
| I _{GSX} | Input Current "OFF" | 4.5V ≤ V _{GD} ≤ 11V, V _{SD} = 0.7V T _A = 85°C | 0.01 | 0.2 10 | nA nA |
| I _{D(OFF)} | Leakage Current "OFF" | V _{SD} = 0.7V, V _{GS} = 3.8V T _A = 85°C | 0.02 | 0.2 10 | nA nA |
| I _{G(ON)} | Leakage Current "ON" | V _{GD} = 0V, I _S = 1 mA T _A = 85°C | 0.08 | 1 200 | nA nA |
| I _{G(ON)} | Leakage Current "ON" | V _{GD} = 0V, I _S = 2 mA T _A = 85°C | 0.13 | 5 10 | nA μA |
| I _{G(ON)} | Leakage Current "ON" | V _{GD} = 0V, I _S = -2 mA T _A = 85°C | 0.1 | 10 20 | nA μA |
| r _{DS(ON)} | Drain-Source Resistance | V _{GS} = 0.35V, I _S = 2 mA T _A = +85°C | 90 | 150 240 | Ω Ω |
| V _{DIODE} | Forward Diode Drop | I _D = 0.5 mA | | 0.8 | V |
| r _{DS(ON)} | Match | V _{GS} = 0V, I _D = 1 mA | 4 | 20 | Ω |
| T _{ON} | Turn "ON" Time | See AC Test Circuit | 150 | 500 | ns |
| T _{OFF} | Turn "OFF" Time | See AC Test Circuit | 300 | 500 | ns |
| CT | Cross Talk | See AC Test Circuit | 120 | | dB |

Electrical Characteristics AH5011 (Notes 2 and 3)

| Symbol | Parameter | Conditions | Typ | Max | Units |
|---------------------|-------------------------|------------------------------------------------------------------------------|------|------------|----------|
| I _{GSX} | Input Current "OFF" | 11V ≤ V _{GD} ≤ 15V, V _{SD} = 0.7V T _A = 85°C | 0.01 | 0.2 10 | nA nA |
| I _{D(OFF)} | Leakage Current "OFF" | V _{SD} = 0.7V, V _{GS} = 10.3V T _A = 85°C | 0.01 | 0.2 10 | nA nA |
| I _{G(ON)} | Leakage Current "ON" | V _{GD} = 0V, I _S = 1 mA T _A = 85°C | 0.04 | 0.5 100 | nA nA |
| I _{G(ON)} | Leakage Current "ON" | V _{GD} = 0V, I _S = 2 mA T _A = 85°C | | 2 1 | nA μA |
| I _{G(ON)} | Leakage Current "ON" | V _{GD} = 0V, I _S = -2 mA T _A = 85°C | | 5 2 | nA μA |
| r _{DS(ON)} | Drain-Source Resistance | V _{GS} = 1.5V, I _S = 2 mA T _A = 85°C | 60 | 100 160 | Ω Ω |
| V _{DIODE} | Forward Diode Drop | I _D = 0.5 mA | | 0.8 | V |
| r _{DS(ON)} | Match | V _{GS} = 0V, I _D = 1 mA | 2 | 10 | Ω |
| T _{ON} | Turn "ON" Time | See AC Test Circuit | 150 | 50 | ns |
| T _{OFF} | Turn "OFF" Time | See AC Test Circuit | 300 | 500 | ns |
| CT | Cross Talk | See AC Test Circuit. f = 100 Hz. | 120 | | dB |

Note 1: Absolute maximum ratings indicate limits beyond which damage to the device may occur. DC and AC electrical specifications do not apply when operating the device beyond its specified operating conditions.

Note 2: Test conditions 25°C unless otherwise noted.

Note 3: "OFF" and "ON" notation refers to the conduction state of the FET switch.

Note 4: Thermal Resistance:

| | |
|------------|---------------|
| | θ_{JA} |
| N14A, N16A | 92°C/W |
| M14A, M16A | 115°C/W |

Test Circuits and Switching Time Waveforms

Cross Talk Test Circuit

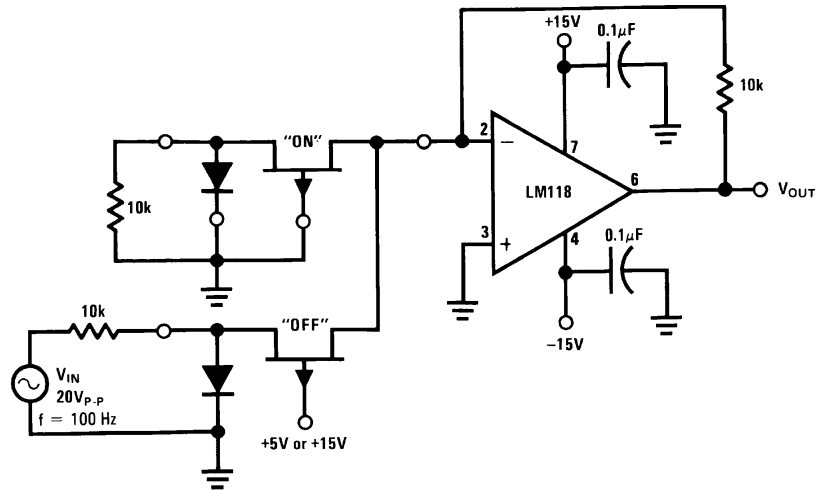

AC Test Circuit

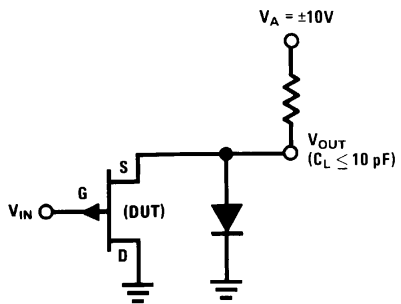

Time Waveforms

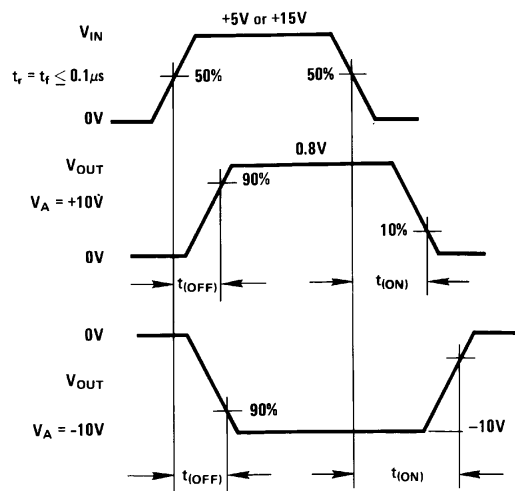

TL/H/5659-2

Typical Performance Characteristics

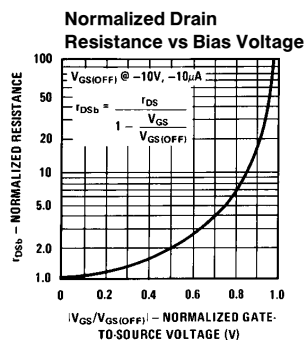
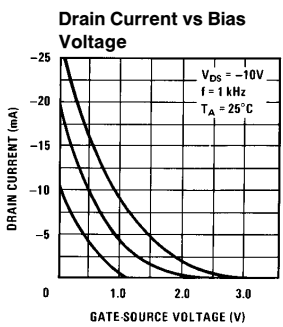
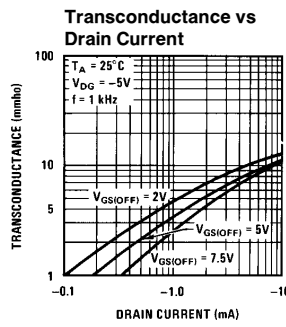
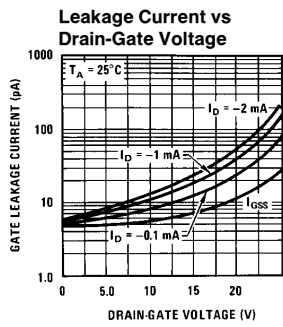
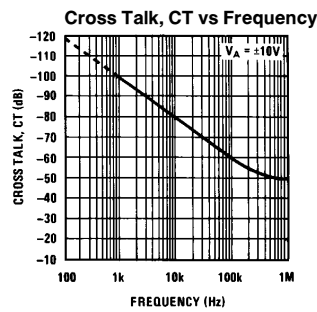
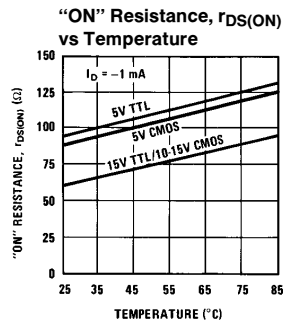
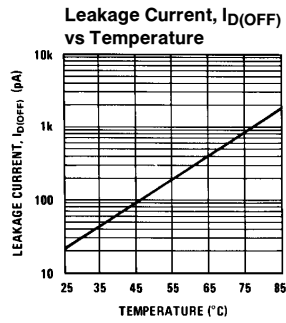
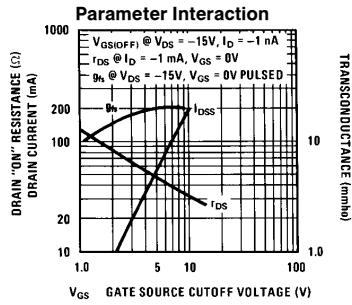

TL/H/5659-3

Applications Information

Theory of Operation

The AH series of analog switches are primarily intended for operation in current mode switch applications; i.e., the drains of the FET switch are held at or near ground by operating into the summing junction of an operational amplifier. Limiting the drain voltage to under a few hundred millivolts eliminates the need for a special gate driver, allowing the switches to be driven directly by standard TTL, 5V-10V CMOS, open collector 15V TTL/CMOS.

Two basic switch configurations are available: 4 independent switches (SPST) and 4 pole switches used for multiplexing (4 PST-MUX). The MUX versions such as the AH5010 offer common drains and include a series FET operated at $V_{GS} = 0V$. The additional FET is placed in the feedback path in order to compensate for the "ON" resistance of the switch FET as shown in Figure 1.

The closed-loop gain of Figure 1 is:

$$A_{VCL} = \frac{R2 + r_{DS(ON)Q2}}{R1 + r_{DS(ON)Q1}}$$

For $R1 = R2$, gain accuracy is determined by the $r_{DS(ON)}$ match between Q1 and Q2. Typical match between Q1 and Q2 is 4 ohms resulting in a gain accuracy of 0.05% (for $R1 = R2 = 10\text{ k}\Omega$).

Noise Immunity

The switches with the source diodes grounded exhibit improved noise immunity for positive analog signals in the

"OFF" state. With $V_{IN} = 15V$ and the $V_A = 10V$, the source of Q1 is clamped to about 0.7V by the diode ($V_{GS} = 14.3V$) ensuring that ac signals imposed on the 10V input will not gate the FET "ON."

Selection of Gain Setting Resistors

Since the AH series of analog switches are operated in current mode, it is generally advisable to make the signal current as large as possible. However, current through the FET switch tends to forward bias the source to gate junction and the signal shunting diode resulting in leakage through these junctions. As shown in Figure 2, $I_{G(ON)}$ represents a finite error in the current reaching the summing junction of the op amp.

Secondly, the $r_{DS(ON)}$ of the FET begins to "round" as I_S approaches I_{DSS} . A practical rule of thumb is to maintain I_S at less than $1/10$ of I_{DSS} .

Combining the criteria from the above discussion yields:

$$R1_{min} \geq \frac{V_A(MAX) A_D}{I_{G(ON)}} \quad (2a)$$

or:

$$\geq \frac{V_A(MAX)}{I_{DSS}/10} \quad (2b)$$

whichever is larger.

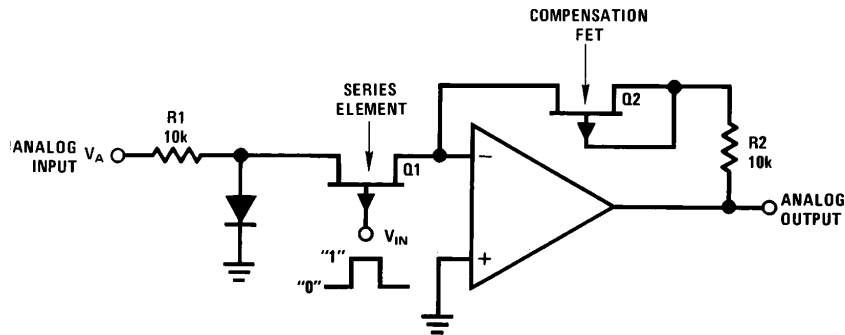

FIGURE 1. Use of Compensation FET

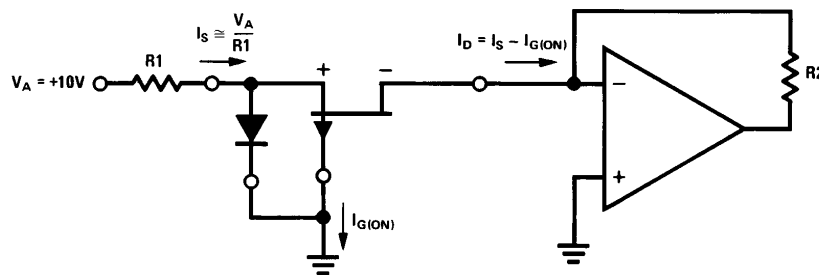

FIGURE 2. On Leakage Current, $I_{G(ON)}$

TL/H/5659-4

Applications Information (Continued)

Where: $V_{A(MAX)}$ = Peak amplitude of the analog input signal
 A_D = Desired accuracy
 $I_{G(ON)}$ = Leakage at a given I_S
 I_{DSS} = Saturation current of the FET switch
 $\cong 20 \text{ mA}$

In a typical application, V_A might = $\pm 10\text{V}$, $A_D = 0.1\%$, $0^\circ\text{C} \leq T_A \leq 85^\circ\text{C}$. The criterion of equation (2b) predicts:

$$R1_{(MIN)} \geq \frac{(10\text{V})}{\left(\frac{20 \text{ mA}}{10}\right)} = 5 \text{ k}\Omega$$

For $R1 = 5\text{k}$, $I_S \cong 10\text{V}/5\text{k}$ or 2 mA. The electrical characteristics guarantee an $I_{G(ON)} \leq 1 \mu\text{A}$ at 85°C for the AH5010. Per the criterion of equation (2a):

$$R1_{(MIN)} \geq \frac{(10\text{V})(10^{-3})}{1 \times 10^{-6}} \geq 10 \text{ k}\Omega$$

Since equation (2a) predicts a higher value, the 10k resistor should be used.

The "OFF" condition of the FET also affects gain accuracy. As shown in Figure 3, the leakage across Q2, $I_{D(OFF)}$ represents a finite error in the current arriving at the summing junction of the op amp.

Accordingly:

$$R1_{(MAX)} \leq \frac{V_{A(MIN)} A_D}{(N) I_{D(OFF)}}$$

Where: $V_{A(MIN)}$ = Minimum value of the analog input signal

A_D = Desired accuracy

N = Number of channels

$I_{D(OFF)}$ = "OFF" leakage of a given FET switch

As an example, if $N = 10$, $A_D = 0.1\%$, and $I_{D(OFF)} \leq 10 \text{ nA}$ at 85°C for the AH5010. $R1_{(MAX)}$ is:

$$R1_{(MAX)} \leq \frac{(1\text{V})(10^{-3})}{(10)(10 \times 10^{-9})} = 10\text{k}$$

Selection of $R2$, of course, depends on the gain desired and for unity gain $R1 = R2$.

Lastly, the foregoing discussion has ignored resistor tolerances, input bias current and offset voltage of the op amp—all of which should be considered in setting the overall gain accuracy of the circuit.

TTL Compatibility

The AH series can be driven with two different logic voltage swings: the even numbered part types are specified to be driven from standard 5V TTL logic and the odd numbered types from 15V open collector TTL.

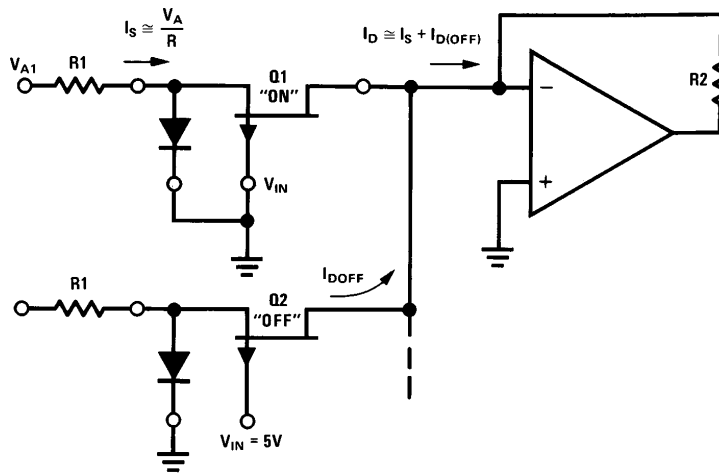

FIGURE 3

TL/H/5659-5

Applications Information (Continued)

Standard TTL gates pull-up to about 3.5V (no load). In order to ensure turn-off of the even numbered switches such as AH5010, a pull-up resistor, R_{EXT} , of at least 10 k Ω should be placed between the 5V V_{CC} and the gate output as shown in Figure 4.

Likewise, the open-collector, high voltage TTL outputs should use a pull-up resistor as shown in Figure 5. In

both cases, t_{OFF} is improved for lower values of R_{EXT} at the expense of power dissipation in the low state.

Definition of Terms

The terms referred to in the electrical characteristics tables are as defined in Figure 6.

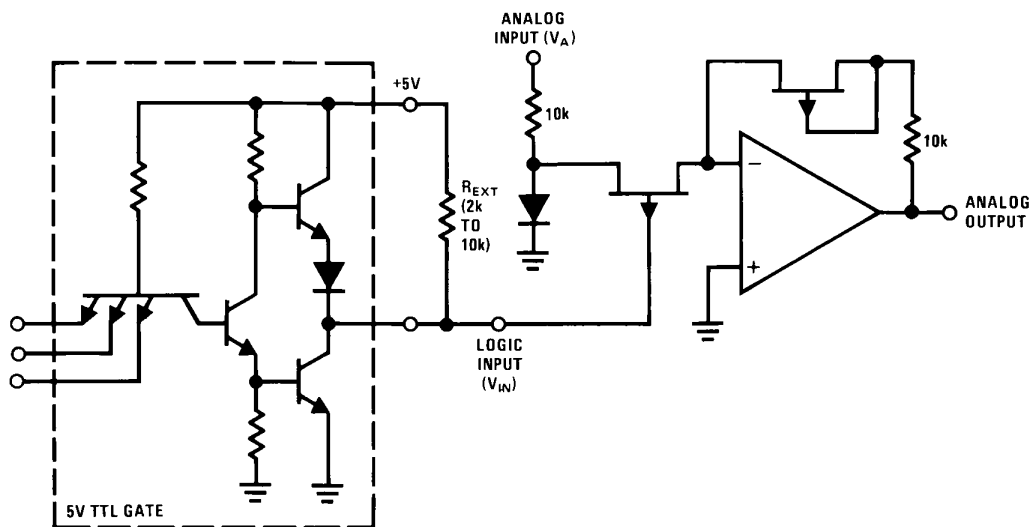

FIGURE 4. Interfacing with +5V TTL

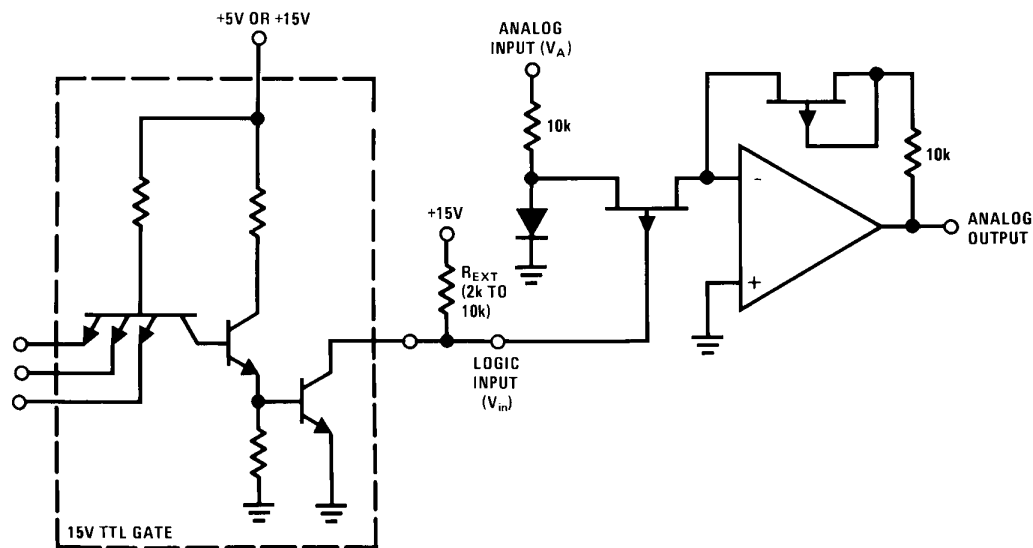

FIGURE 5. Interfacing with +15V Open Collector TTL

TL/H/5659-6

Applications Information (Continued)

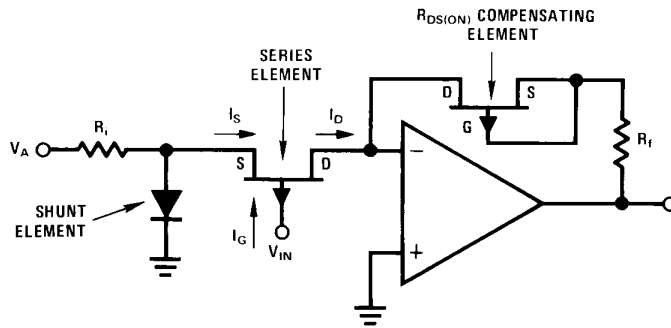
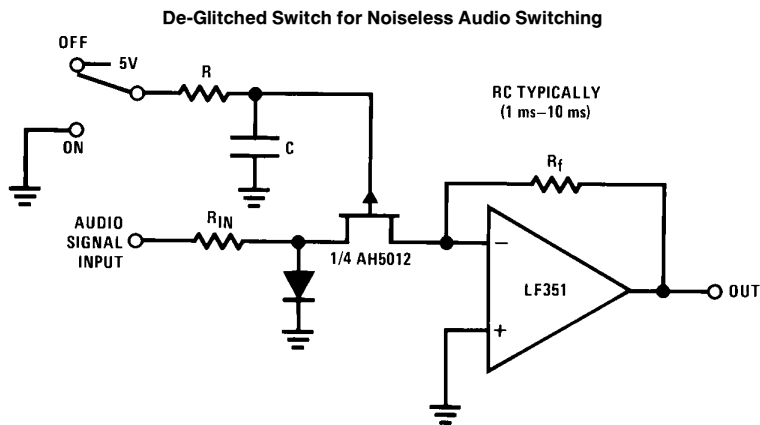

FIGURE 6. Definition of Terms

Typical Applications



TL/H/5659-7

Typical Applications (Continued)

3-Channel Multiplexer with Sample and Hold

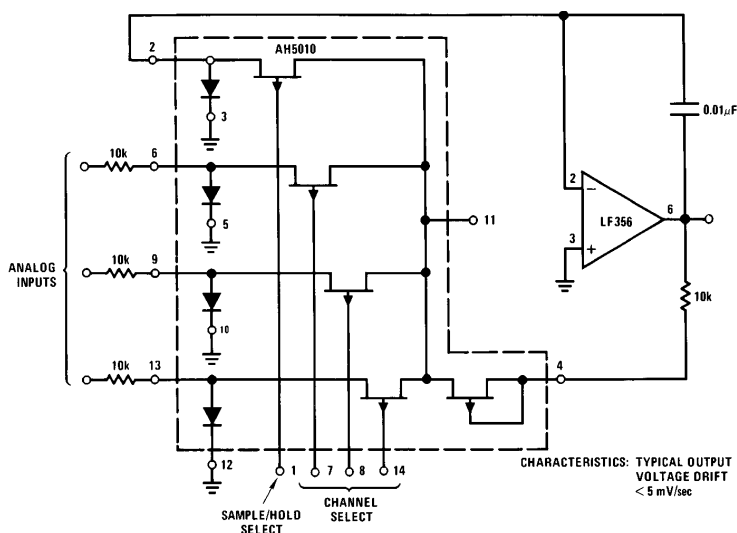

TL/H/5659-8

8-Bit Binary (BCD) Multiplying D/A Converter*

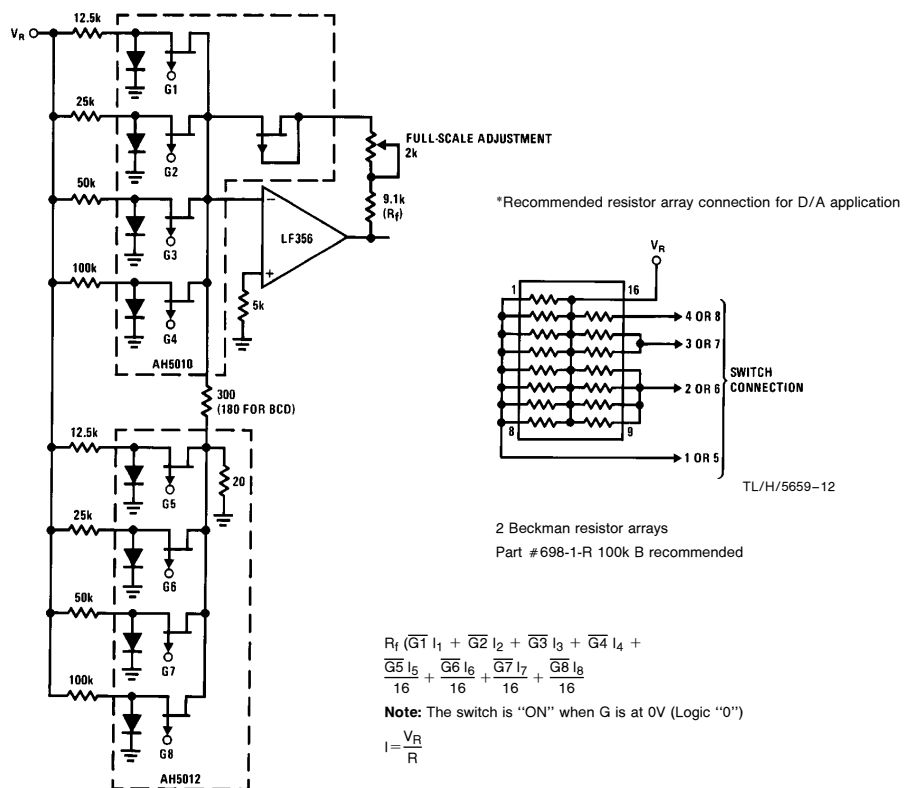

TL/H/5659-12

TL/H/5659-11

Typical Applications (Continued) 16-Channel Multiplexer

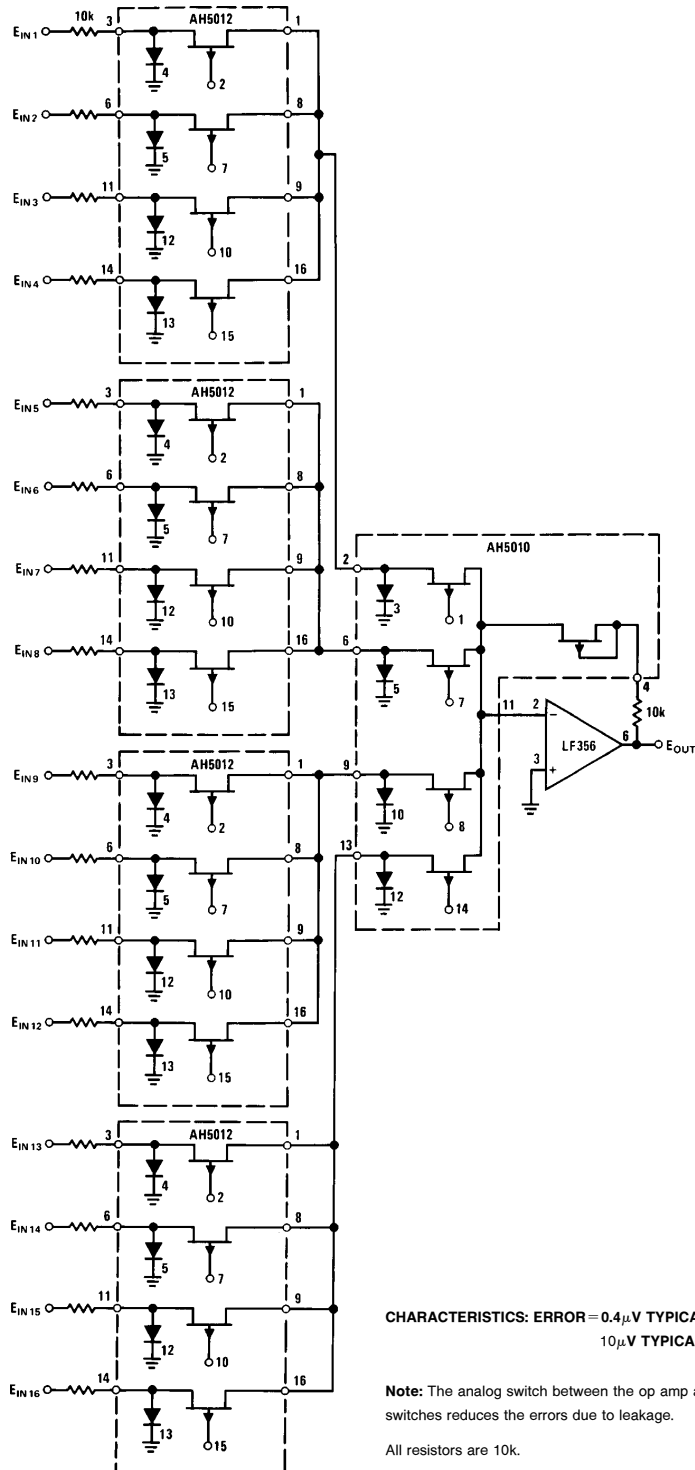

Typical Applications (Continued)

Gain Programmable Amplifier

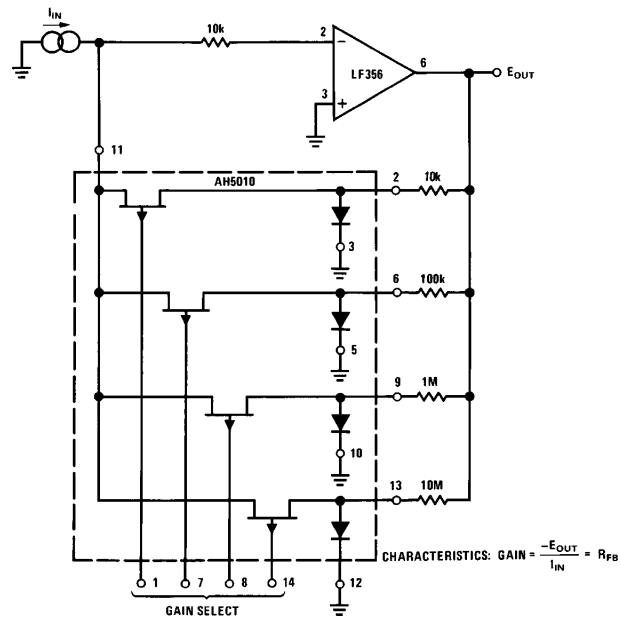

TL/H/5659-10

Physical Dimensions inches (millimeters)

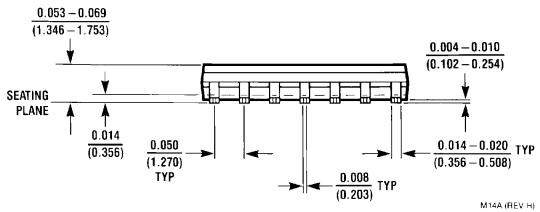
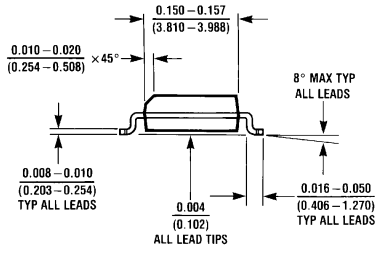
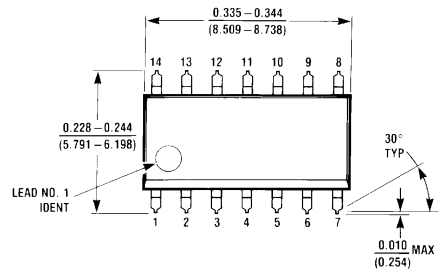

M14A (REV H)

Small Outline Package (M)
Order Number AH5010CM
NS Package Number M14A

Physical Dimensions inches (millimeters) (Continued)

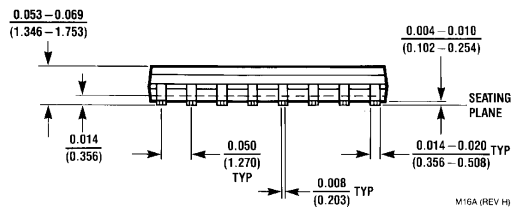
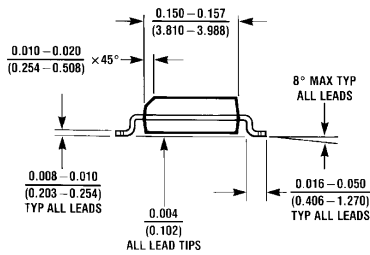
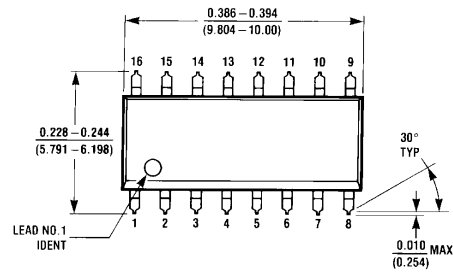

M16A (REV H)

Small Outline Package (M)
Order Number AH5012CM
NS Package Number M16A

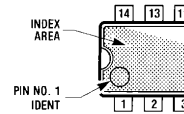
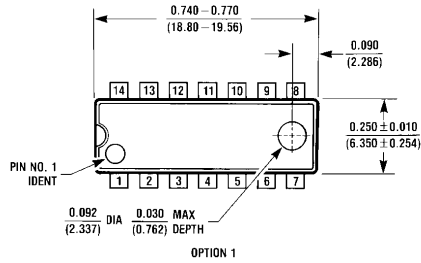

OPTION 2

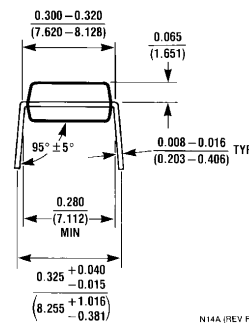
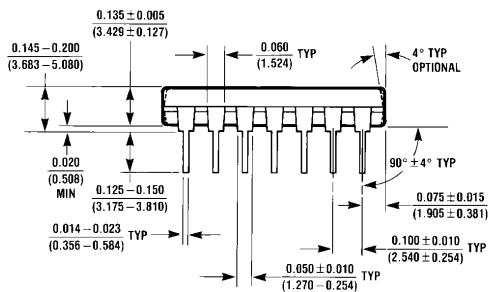

N14A (REV F)

Dual-In-Line Package (N)
Order Number AH5010CN
NS Package Number N14A

Physical Dimensions inches (millimeters) (Continued)

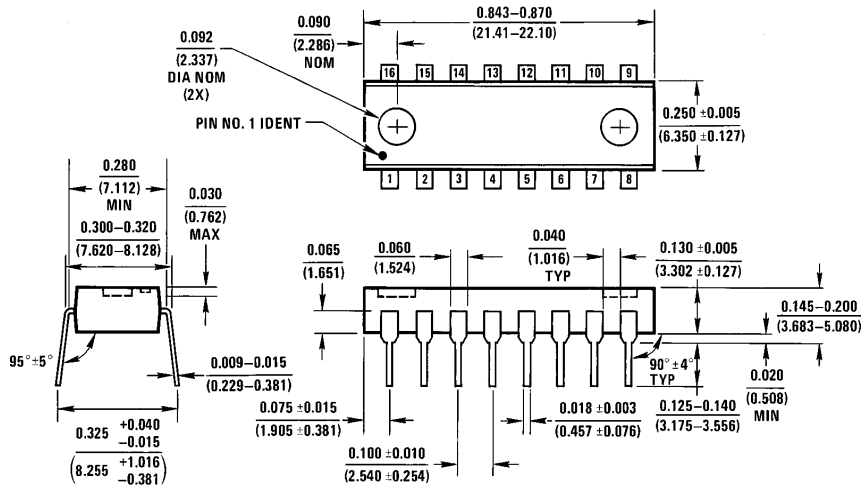

Dual-In-Line Package (N)
Order Number AH5011CN or AH5012CN
NS Package Number N16A

N16A (REV E)

LIFE SUPPORT POLICY

NATIONAL'S PRODUCTS ARE NOT AUTHORIZED FOR USE AS CRITICAL COMPONENTS IN LIFE SUPPORT DEVICES OR SYSTEMS WITHOUT THE EXPRESS WRITTEN APPROVAL OF THE PRESIDENT OF NATIONAL SEMICONDUCTOR CORPORATION. As used herein:

1. Life support devices or systems are devices or systems which, (a) are intended for surgical implant into the body, or (b) support or sustain life, and whose failure to perform, when properly used in accordance with instructions for use provided in the labeling, can be reasonably expected to result in a significant injury to the user.
2. A critical component is any component of a life support device or system whose failure to perform can be reasonably expected to cause the failure of the life support device or system, or to affect its safety or effectiveness.



National Semiconductor Corporation
 1111 West Bardin Road
 Arlington, TX 76017
 Tel: 1(800) 272-9959
 Fax: 1(800) 737-7018

National Semiconductor Europe
 Fax: (+49) 0-180-530 85 86
 Email: onjwge@tevm2.nsc.com
 Deutsch Tel: (+49) 0-180-530 85 85
 English Tel: (+49) 0-180-532 78 32
 Français Tel: (+49) 0-180-532 93 58
 Italiano Tel: (+49) 0-180-534 16 80

National Semiconductor Hong Kong Ltd.
 19th Floor, Straight Block,
 Ocean Centre, 5 Canton Rd.
 Tsimshatsui, Kowloon
 Hong Kong
 Tel: (852) 2737-1600
 Fax: (852) 2736-9960

National Semiconductor Japan Ltd.
 Tel: 81-043-299-2309
 Fax: 81-043-299-2408

National does not assume any responsibility for use of any circuitry described, no circuit patent licenses are implied and National reserves the right at any time without notice to change said circuitry and specifications.