

## Precision Wide Bandwidth LanSwitch Quad 2:1 Mux/DeMux

### Features

- Single 3.3V/5V supply operation
- Rail-To-Rail Operation
- Very Low Distortion: 2%
- Replaces mechanical relays
- High-performance, low-cost solution for switching between different LAN signals
- Low crosstalk:  $-70\text{dB}$  @ 30 Mbps
- Low insertion loss and On-Resistance: 6-ohms typical
- Off isolation:  $-55\text{dB}$  @ 30 Mbps
- Wide bandwidth data rates  $>135$  Mbps
- Low Quiescent Supply Current (100nA typical)
- Packaging (Pb-free & Green available):
  - 16-pin 150-mil wide plastic SOIC (W)
  - 16-pin 150-mil wide plastic QSOP (Q)
  - 16-pin 173-mil wide plastic TSSOP (L)

### Description

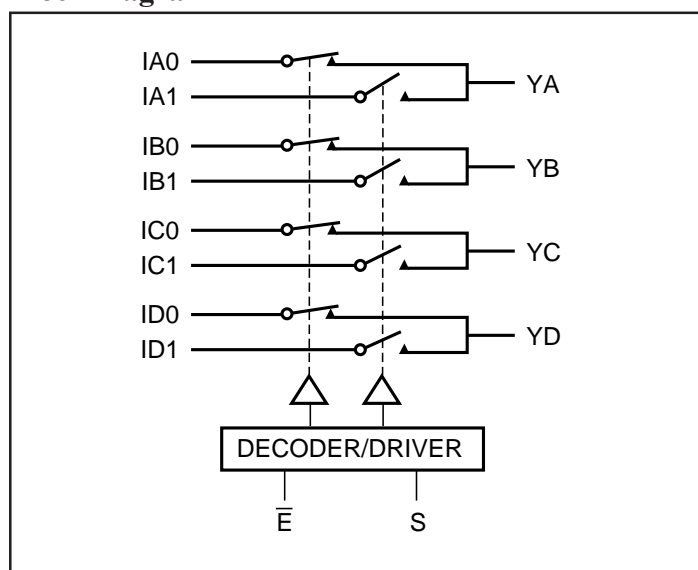
Pericom Semiconductor's PI5L200 is a Rail-to-Rail Quad 2:1 multiplexer/demultiplexer LanSwitch with 3-state outputs. The On-Resistance typically varies from 5 ohms to 7 ohms with data inputs of 0V to 5V. Generally, this part can be used to replace mechanical relays in low voltage (3.3V/5V systems) LAN applications.

With a wide bandwidth of 135 MHz, the PI5L200 can switch Fast Ethernet and ATM25 signals. Into 100-ohm UTP cables, the switch distortion is typically less than two percent. Crosstalk @30 MHz is  $-70\text{dB}$ . The PI5L200 operates from a single 3.3V/5V supply and interface to TTL logic.

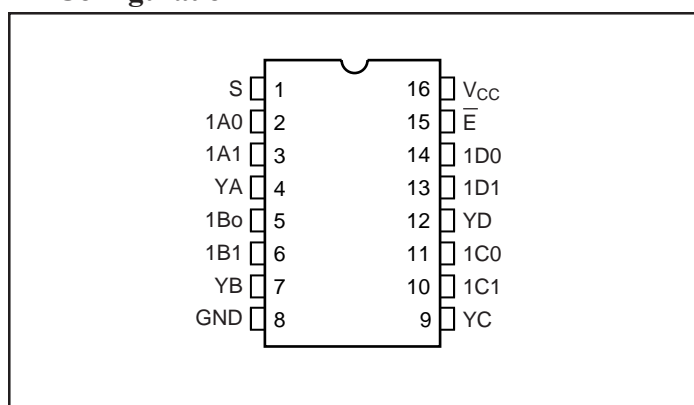
### Applications

- 10/100 Base-TX/T4
- 100VG-AnyLAN
- Token Ring 4/16 Mbps
- ATM25
- NIC Adapter and Hubs
- SONET OCI 51.8Mbps
- T1/E1

### Block Diagram



### Pin Configuration



### Truth Table<sup>(1)</sup>

$\bar{E}$	S	YA	YB	YC	YD	Function
H	X	Hi-Z	Hi-Z	Hi-Z	Hi-Z	Disable
L	L	IA0	IB0	IC0	ID0	S = 0
L	H	IA1	IB1	IC1	ID1	S = 1

#### Note:

1. H = High Voltage Level  
L = Low Voltage Level  
Switches are shown with logic "0" input (Select and Enable)

### Pin Description

Pin Name	Description
IA <sub>n</sub> -ID <sub>n</sub>	Data Inputs
S	Select Inputs
$\bar{E}$	Enable
YA-YD	Data Outputs
GND	Ground
V <sub>CC</sub>	Power

### Maximum Ratings

(Above which the useful life may be impaired. For user guidelines, not tested.)

Storage Temperature .....	-65°C to +150°C
Ambient Temperature with Power Applied .....	-40°C to +85°C
Supply Voltage to Ground Potential .....	-0.5V to +7.0V
DC Input Voltage .....	-0.5V to $V_{CC}+0.5V$
DC Output Current .....	120mA
Power Dissipation .....	0.5W

**Note:**

Stresses greater than those listed under MAXIMUM RATINGS may cause permanent damage to the device. This is a stress rating only and functional operation of the device at these or any other conditions above those indicated in the operational sections of this specification is not implied. Exposure to absolute maximum rating conditions for extended periods may affect reliability.

### Single 5.0V Supply

**DC Electrical Characteristics** (Over the Operating Range,  $T_A = -40^\circ\text{C}$  to  $+85^\circ\text{C}$ ,  $V_{CC} = 5V \pm 10\%$ ,  $GND = 0V$ )

Parameters	Description	Test Conditions <sup>(1)</sup>	Min.	Typ. <sup>(2)</sup>	Max.	Units
$V_{ANALOG}$	Analog Signal Range		0	—	$V_{CC}$	V
$R_{ON}$	ON-Resistance	$I_{ON} = 10\text{mA}$ to $30\text{mA}$	—	6	12	$\Omega$
$\Delta R_{ON}$	Match Between Channels		—	0.4	2	
$R_{FLAT(ON)}$	$R_{ON}$ Flatness	$I_{ON} = 1\text{mA}$ , $V_{NO}$ , $V_{NC} = 0V$ to $5V$	—	3	5	
$I_{NO(OFF)}$ , $I_{NO(ON)}$	On/Off Leakage Current	$V_{NO}$ , $V_{NC} = 4.5V$	-100	—	100	nA
$I_{CC}$	Quiescent Supply Current	$V_{CC} = 5.5V$ , $V_{IN} = 0V$ or $V_{CC}$	—	—	1	$\mu\text{A}$
$I_O$	Output Current	$V_{NO}$ , $V_{NC}$ or $V_{COM} = 0V$ to $5V$	100	—	—	mA
$V_{IH}$	Input HIGH Voltage	Guaranteed Logic HIGH Level	2.0	—	—	V
$V_{IL}$	Input LOW Voltage	Guaranteed Logic LOW Level	-0.5	—	0.8	
$I_{IH}$	Input HIGH Current	$V_{CC} = \text{Max.}$ , $V_{IN} = V_{CC}$	—	—	$\pm 1$	$\mu\text{A}$
$I_{IL}$	Input LOW Current	$V_{CC} = \text{Max.}$ , $V_{IN} = GND$	—	—	$\pm 1$	

**Dynamic Electrical Characteristics** (Over the Operating Range,  $T_A = -40^\circ\text{C}$  to  $+85^\circ\text{C}$ ,  $V_{CC} = 5V \pm 10\%$ ,  $GND = 0V$ )

Parameters	Description	Test Conditions <sup>(1)</sup>	Min.	Typ. <sup>(2)</sup>	Max.	Units
$t_{ON}$	Turn-on Time	$V_{NO}$ or $V_{NC} = 3.0V$ , see Figure 2	—	10	20	ns
$t_{OFF}$	Turn-off Time	$V_{NO}$ or $V_{NC} = 3.0V$ , see Figure 2	—	5	10	
$X_{TALK}$	Crosstalk	$R_L = 100$ ohms, $f = 30$ MHz, see Figure 4	—	-70	—	dB
$C_{(OFF)}$	NC or NO Capacitance	$f = 1\text{kHz}$	—	13	—	pF
$O_{IRR}$	Off Isolation	$R_L = 100$ ohms, $f = 30$ MHz, see Figure 5	—	-55	—	dB
BW	Bandwidth -3 dB	$R_L = 100$ ohms, see Figure 3	—	137	—	MHz
D	Distortion $DR_{ON/RL}$	$R_L = 100$ ohms	—	2	—	%

**Notes:**

1. For Max. or Min. conditions, use appropriate value specified under Electrical Characteristics for applicable device type.
2. Guaranteed by design.

### Single 3.3V Supply

**DC Electrical Characteristics** (Over the Operating Range,  $T_A = -40^{\circ}\text{C}$  to  $+85^{\circ}\text{C}$ ,  $V_{CC} = 3.3\text{V} \pm 10\%$ ,  $\text{GND} = 0\text{V}$ )

Parameters	Description	Test Conditions <sup>(1)</sup>	Min.	Typ. <sup>(2)</sup>	Max.	Units
$V_{\text{ANALOG}}$	Analog Signal Range		0	—	$V_{CC}$	V
$R_{\text{ON}}$	ON-Resistance	$I_{\text{ON}} = 10\text{mA}$ to $30\text{mA}$	—	15	22	$\Omega$
$\Delta R_{\text{ON}}$	Match Between Channels		—	1	3	
$R_{\text{FLAT(ON)}}$	$R_{\text{ON}}$ Flatness	$I_{\text{ON}} = 1\text{mA}$ , $V_{\text{NO}}$ , $V_{\text{NC}} = 0\text{V}$ to $5\text{V}$	—	7	12	
$I_{\text{NO(OFF)}}$ , $I_{\text{NO(ON)}}$	On/Off Leakage Current	$V_{\text{NO}}$ , $V_{\text{NC}} = 3.0\text{V}$	-100	—	100	nA
$I_{\text{COM(ON)}}$	On Leakage Current	$V_{\text{NO}}$ , $V_{\text{NC}} = 3.0\text{V}$	-100	—	100	$\mu\text{A}$
$I_{\text{O}}$	Output Current	$V_{\text{NO}}$ , $V_{\text{NC}}$ or $V_{\text{COM}} = 0\text{V}$	80	—	—	mA
$V_{\text{IH}}$	Input HIGH Voltage	Guaranteed Logic HIGH Level	2.0	—	—	V
$V_{\text{IL}}$	Input LOW Voltage	Guaranteed Logic LOW Level	-0.5	—	0.8	
$I_{\text{IH}}$	Input HIGH Current	$V_{CC} = \text{Max.}$ , $V_{\text{IN}} = V_{CC}$	—	—	$\pm 1$	$\mu\text{A}$
$I_{\text{IL}}$	Input LOW Current	$V_{CC} = \text{Max.}$ , $V_{\text{IN}} = \text{GND}$	—	—	$\pm 1$	

**Dynamic Electrical Characteristics** (Over the Operating Range,  $T_A = -40^{\circ}\text{C}$  to  $+85^{\circ}\text{C}$ ,  $V_{CC} = 3.3\text{V} \pm 10\%$ ,  $\text{GND} = 0\text{V}$ )

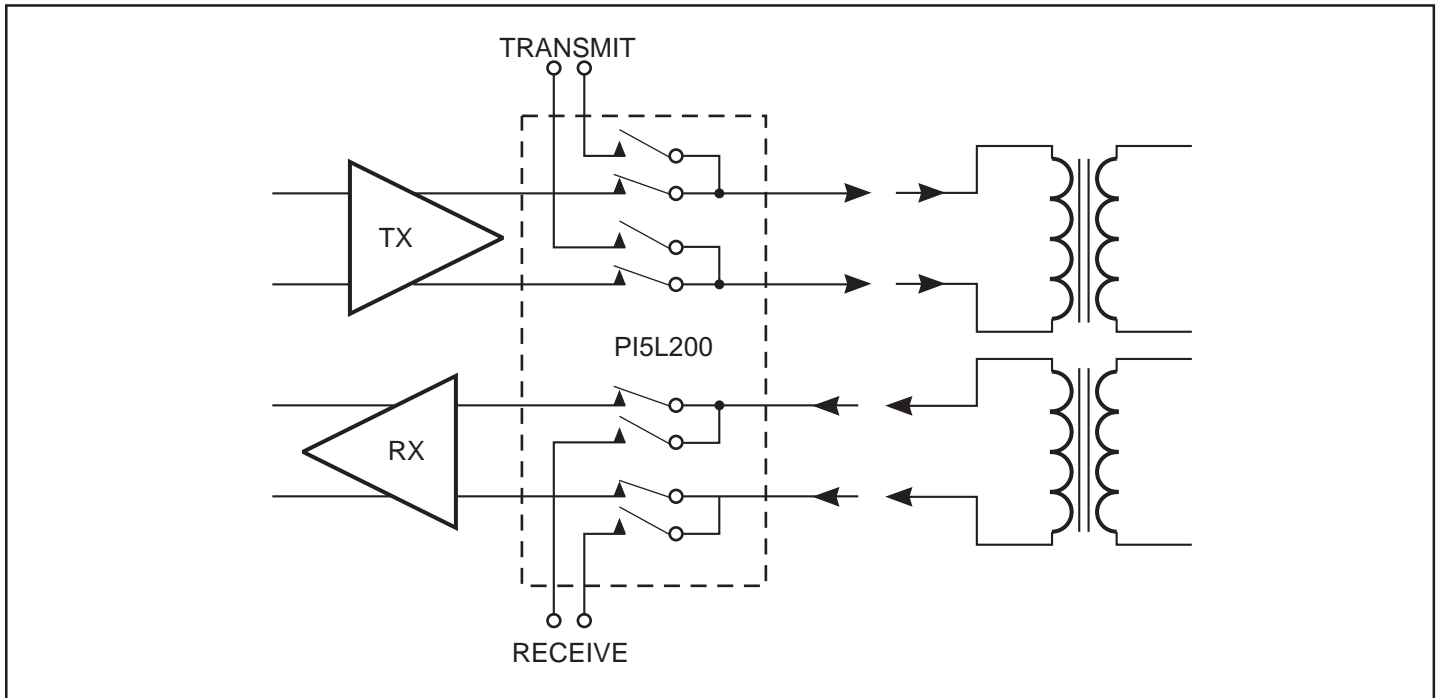
Parameters	Description	Test Conditions <sup>(1)</sup>	Min.	Typ. <sup>(2)</sup>	Max.	Units
$t_{\text{ON}}$	Turn-on Time	$V_{\text{NO}}$ or $V_{\text{NC}} = 1.5\text{V}$ , see Figure 2	—	28	40	ns
$t_{\text{OFF}}$	Turn-off Time	$V_{\text{NO}}$ or $V_{\text{NC}} = 1.5\text{V}$ , see Figure 2	—	4	20	
$X_{\text{TALK}}$	Crosstalk	$R_L = 50$ ohms, $f = 1\text{MHz}$ , see Figure 4	—	-75	—	dB
$C_{\text{(OFF)}}$	NC or NO Capacitance	$f = 1\text{kHz}$	—	15	—	pF
$C_{\text{COM(OFF)}}$	COM Off Capacitance	$f = 1\text{kHz}$	—	30	—	
$O_{\text{IRR}}$	Off Isolation	$R_L = 50$ ohms, $f = 1$ MHz, see Figure 5	—	-75	—	dB
BW	Bandwidth -3 dB	$R_L = 50$ ohms, see Figure 3	—	110	—	MHz
D	Distortion	$R_L = 100$ ohms	—	4	—	%

**DC Electrical Characteristics** (Over the Operating Range,  $T_A = -40^{\circ}\text{C}$  to  $+85^{\circ}\text{C}$ ,  $V_{CC} = 3.3\text{V} \pm 10\%$ ,  $\text{GND} = 0\text{V}$ )

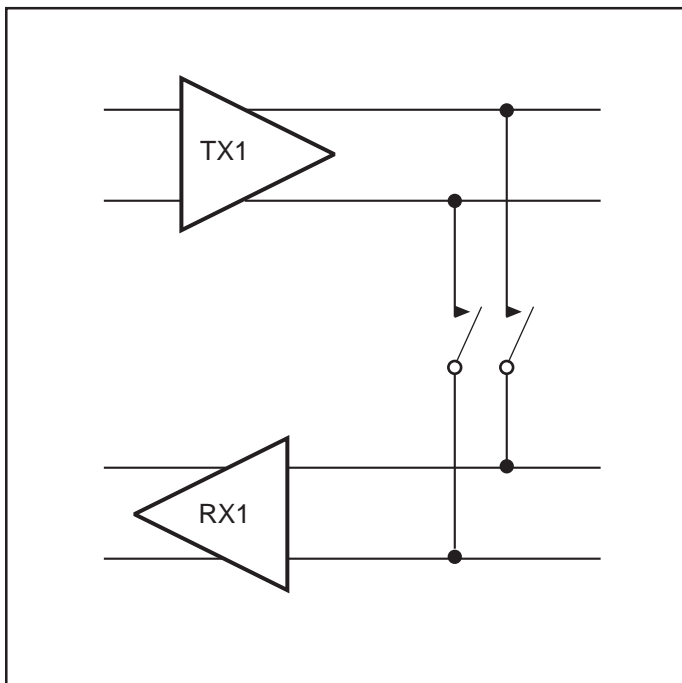
Parameters	Description	Test Conditions <sup>(1)</sup>	Min.	Typ. <sup>(2)</sup>	Max.	Units
$I_{\text{CC}}$	Quiescent Positive Power Supply Current	$V_{CC} = 3.6\text{V}$ , $V_{\text{IN}} = 0\text{V}$ or $V_{CC}$ All Channels On or OFF	—	—	1	$\mu\text{A}$

**Notes:**

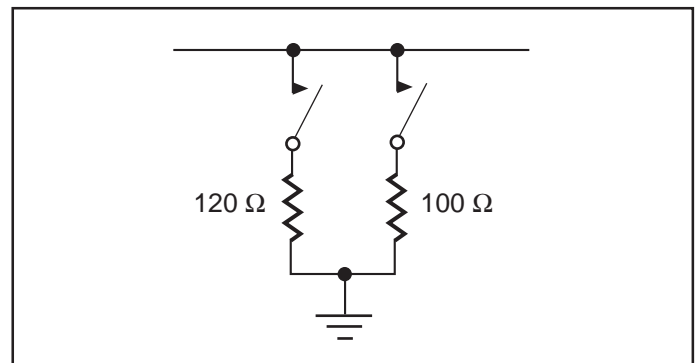
1. For Max. or Min. conditions, use appropriate value specified under Electrical Characteristics for applicable device type.
2. Guaranteed by design.



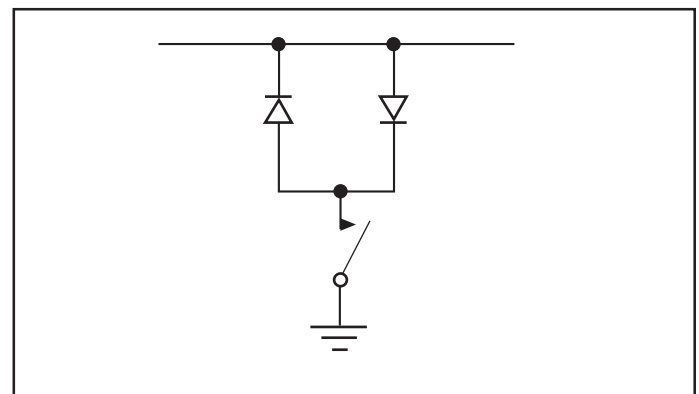
**Figure 1a. Full Duplex Transceiver**



**Figure 1b. Loop Back**

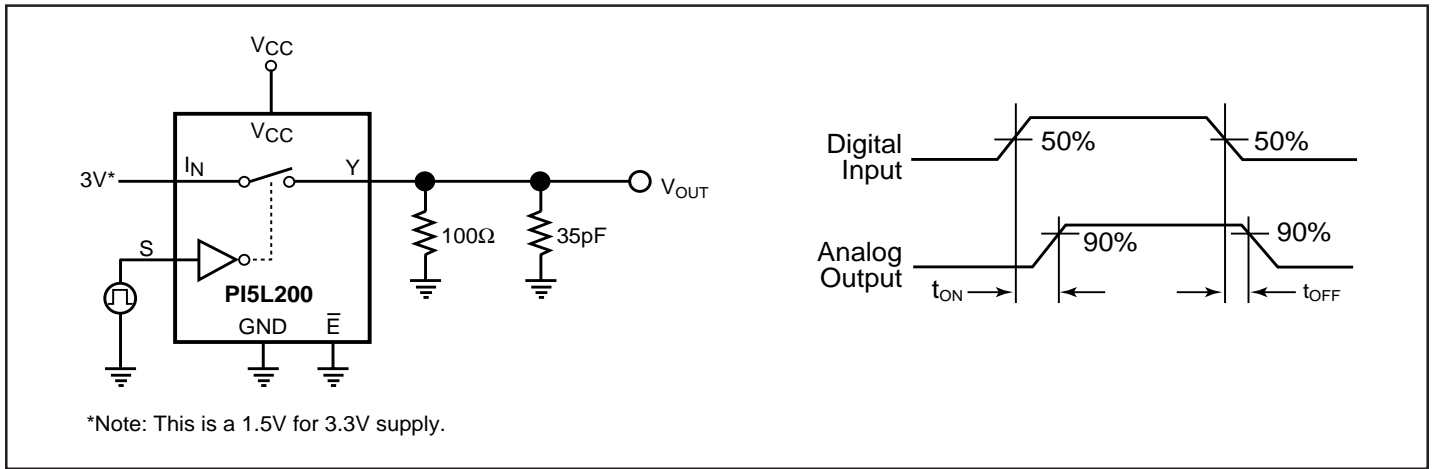


**Figure 1c. Line Termination**

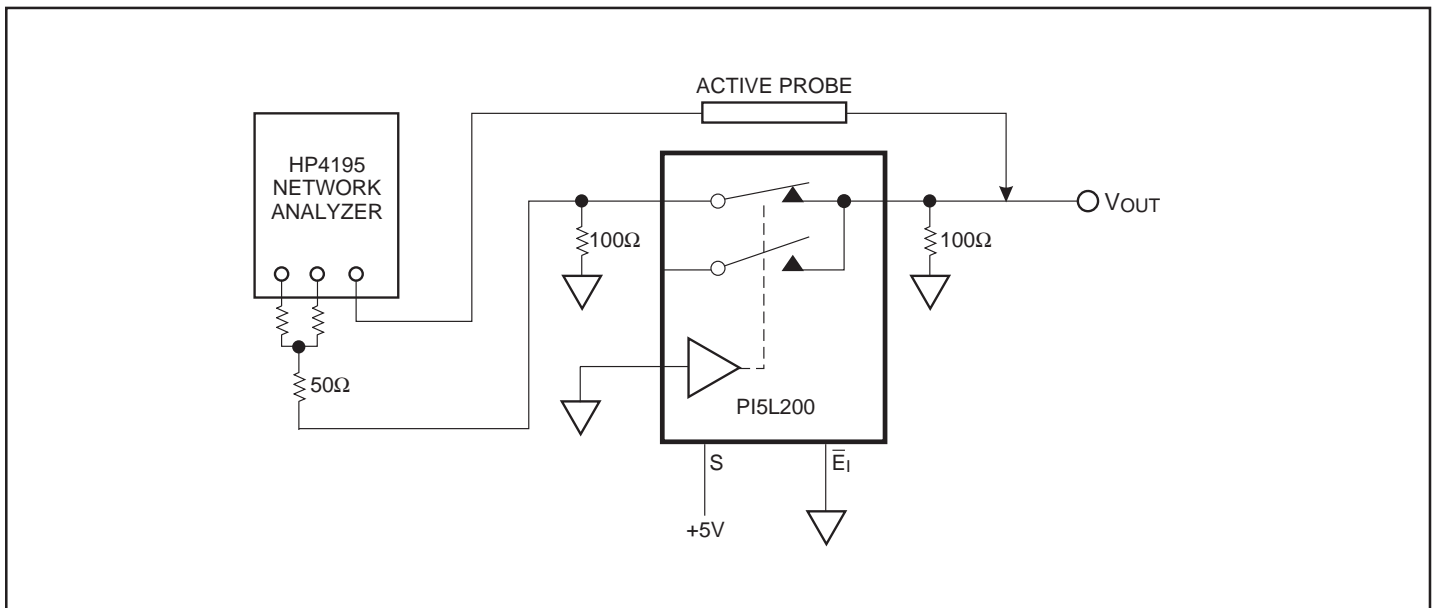


**Figure 1d. Line Clamp**

### Test Circuits

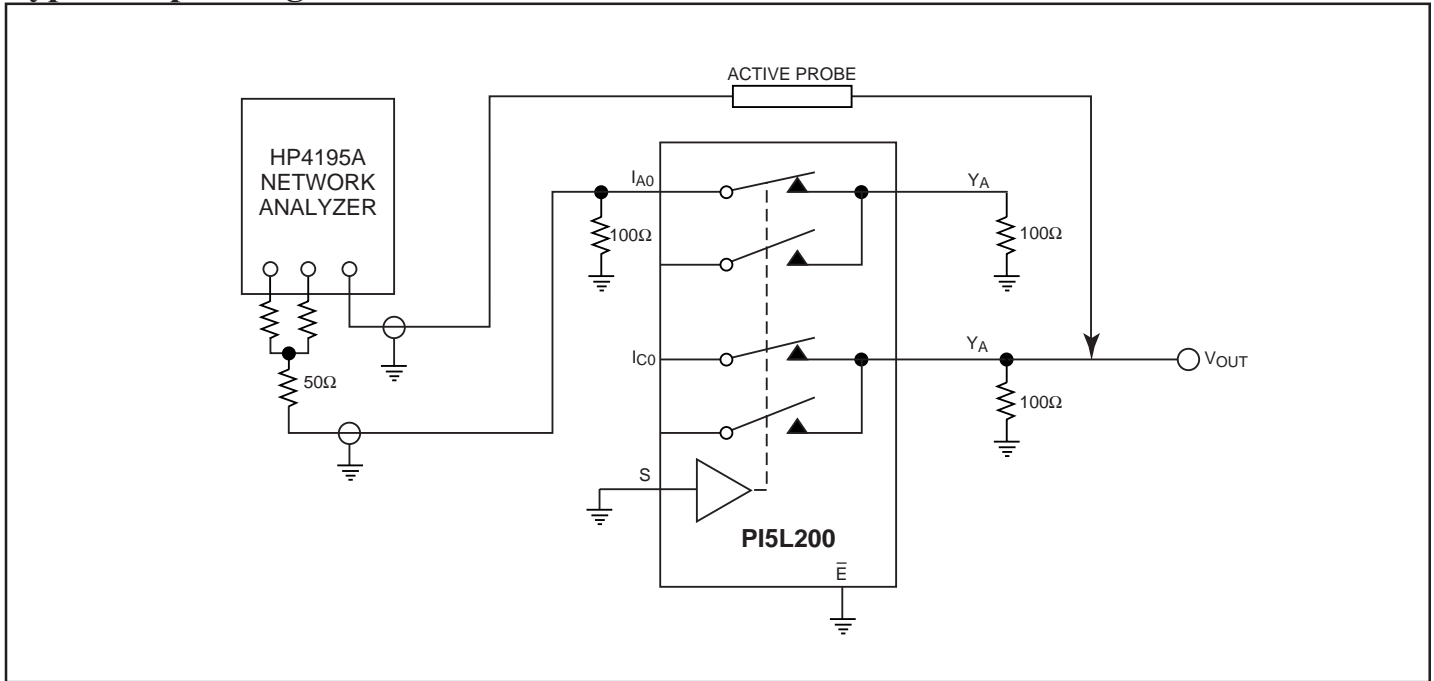


**Figure 2. Switching Time**

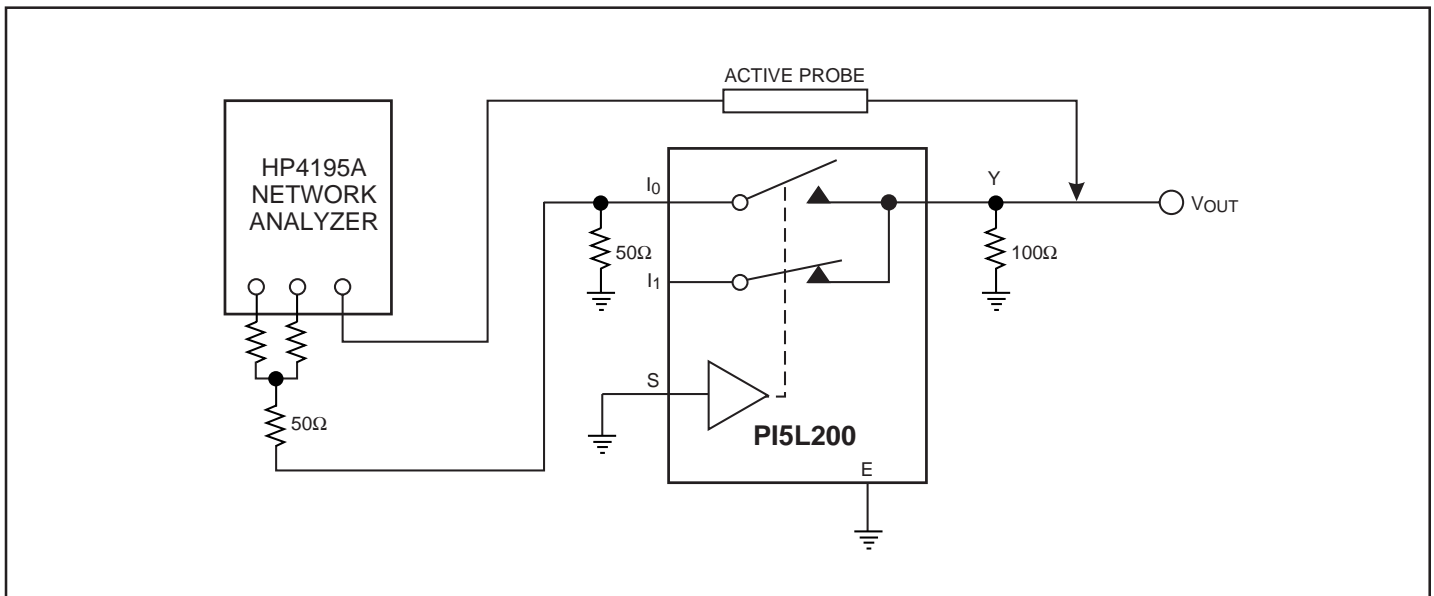


**Figure 3. Bandwidth**

**Typical Operating Characteristics**



**Figure 4. Crosstalk**



**Figure 5. Off Isolation**

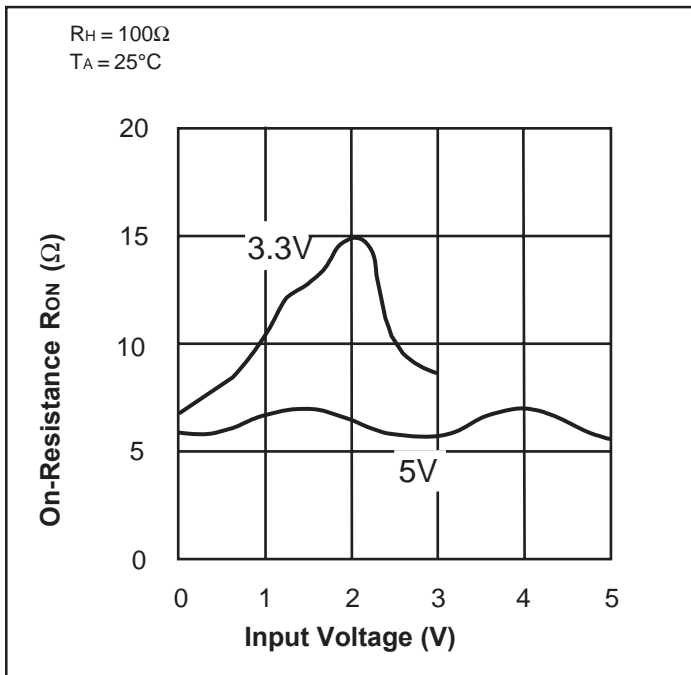


Figure 6. On-Resistance vs. Input Voltage

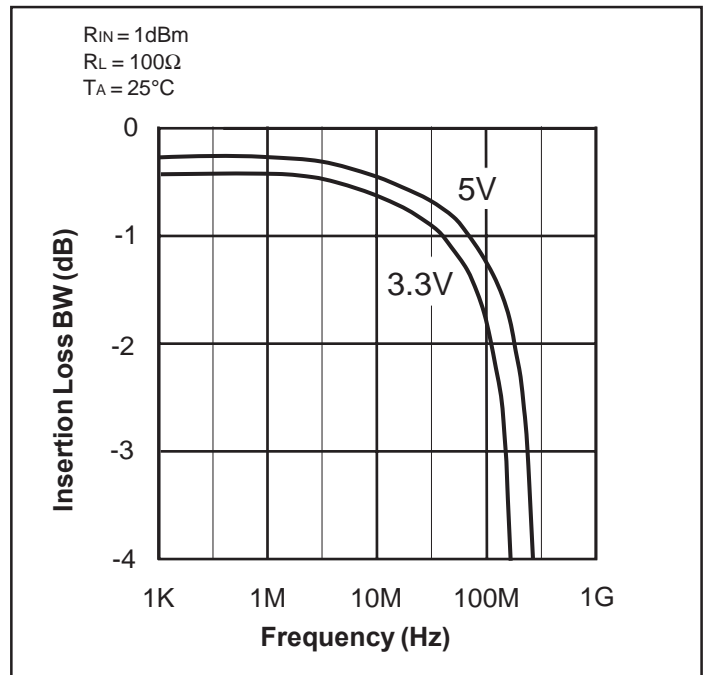


Figure 7. Insertion Loss vs. Frequency

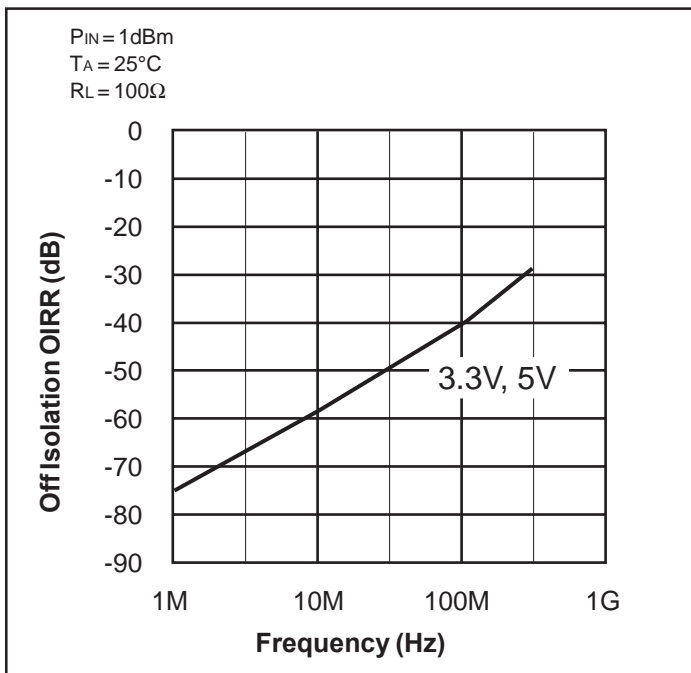


Figure 8. Off Isolation vs. Frequency

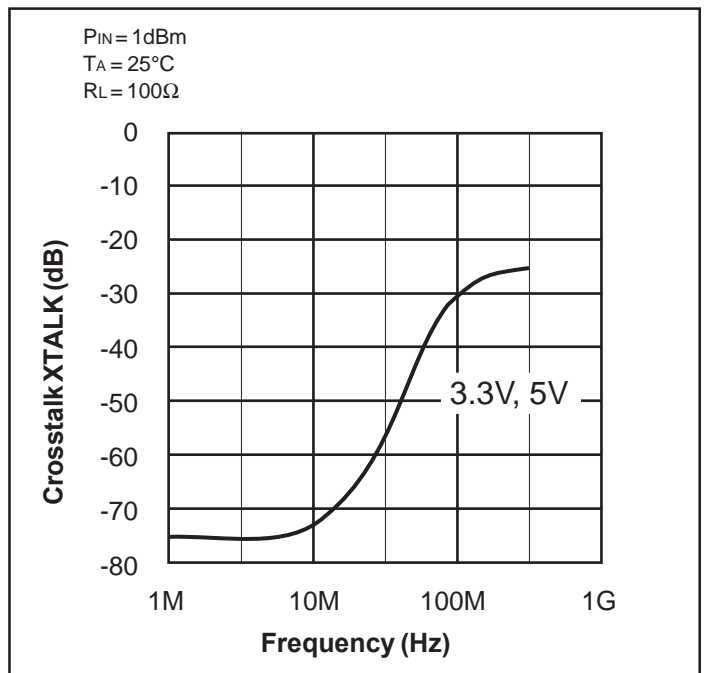
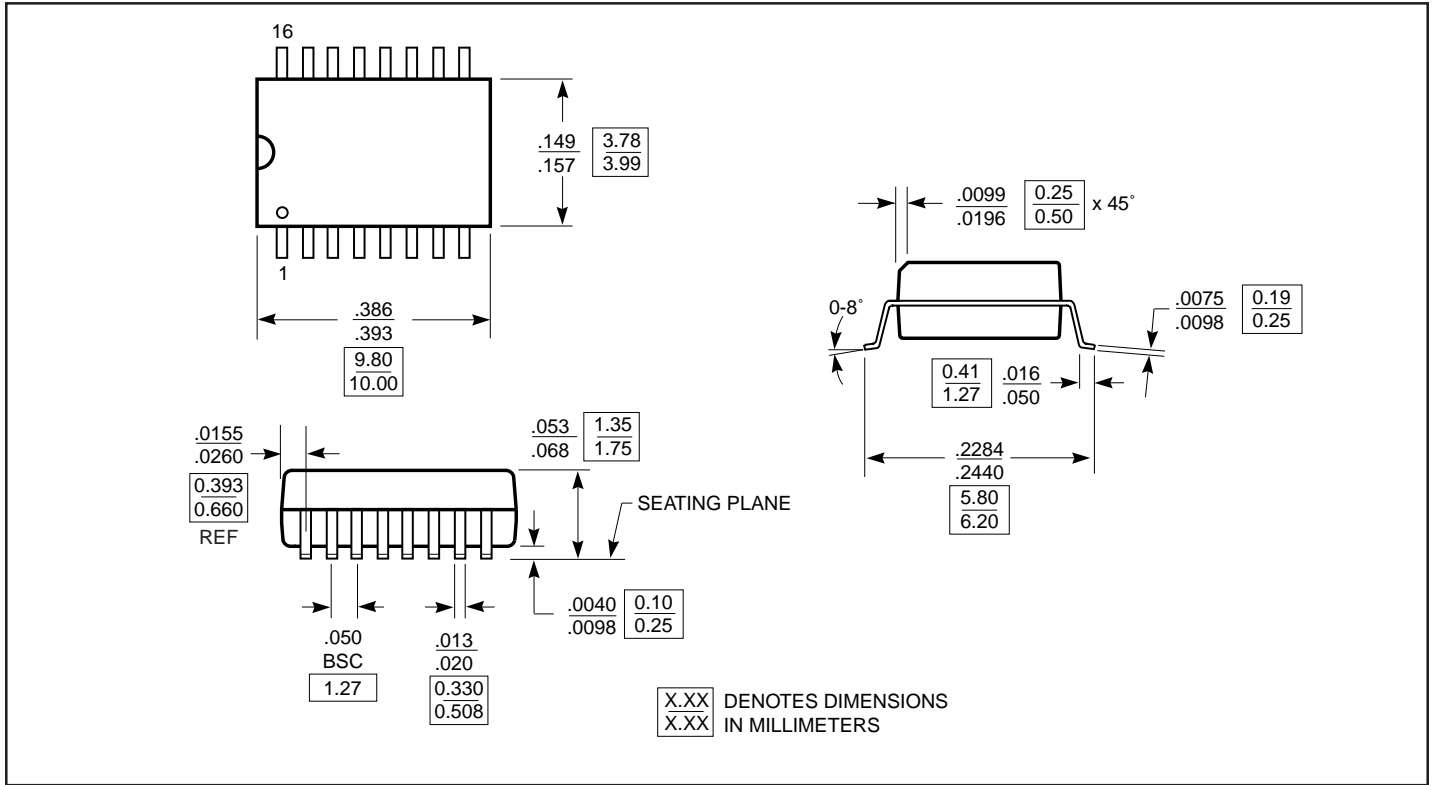
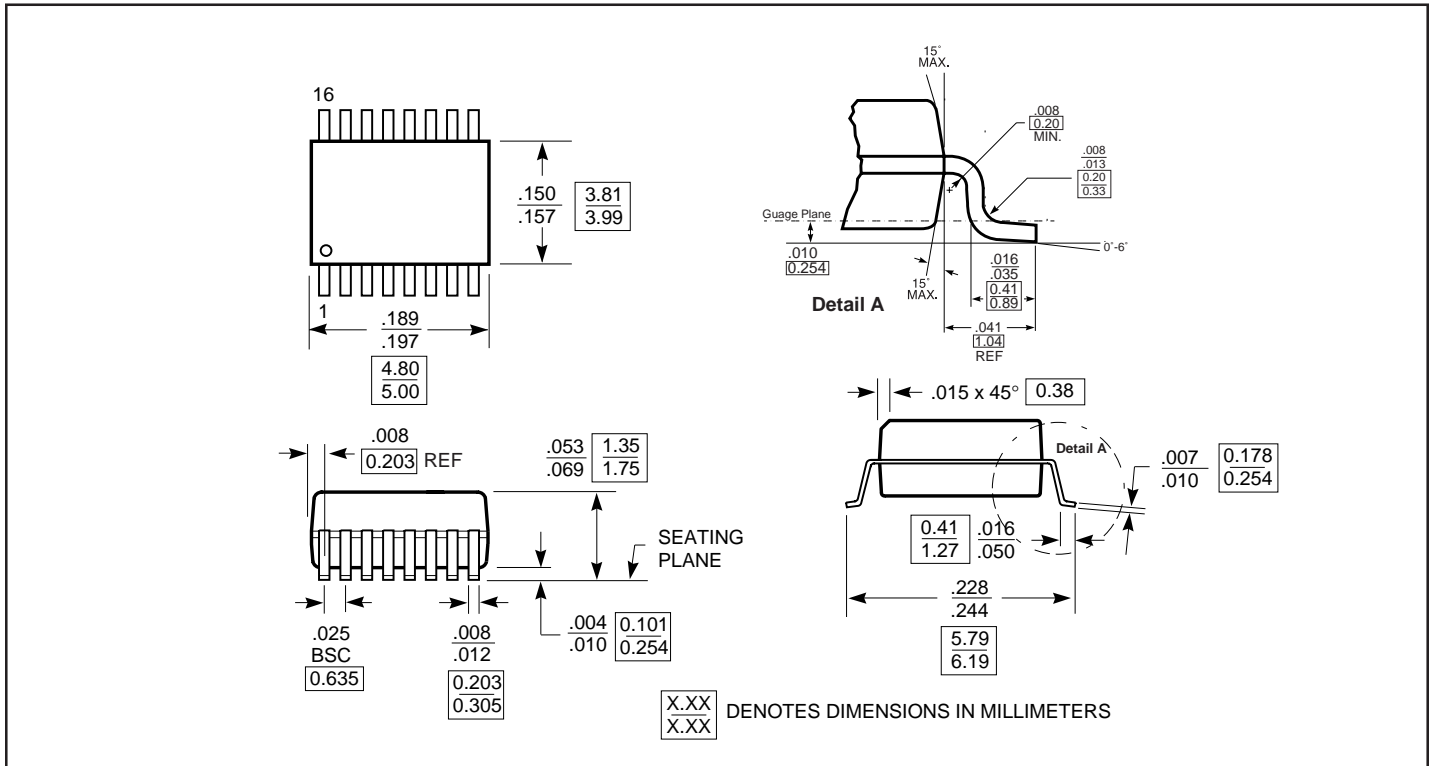


Figure 9. Crosstalk vs. Frequency

**Packaging Mechanical: 16-Pin SOIC (W)**

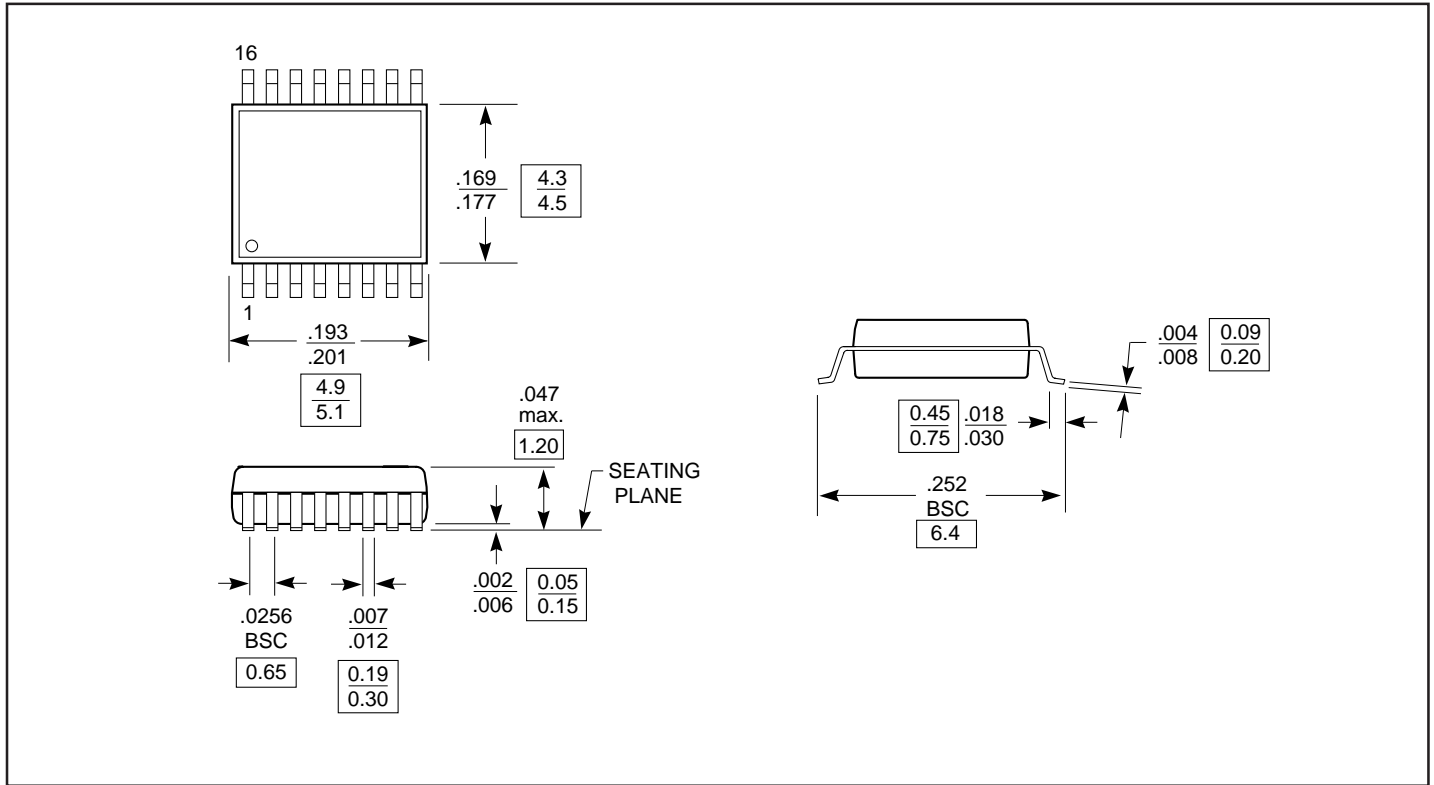


**Packaging Mechanical: 16-Pin QSOP (Q)**





**Packaging Mechanical: 16-Pin TSSOP (L)**



**Ordering Information**

Ordering Code	Package Code	Package Type
PI5L200L	L	16-pin TSSOP
PI5L200LE	L	Pb-free & Green, 16-pin TSSOP
PI5L200Q	Q	16-pin QSOP
PI5L200QE	Q	Pb-free & Green, 16-pin QSOP
PI5L200W	W	16-pin SOIC
PI5L200WE	W	Pb-free & Green, 16-pin SOIC

**Notes:**

- Thermal characteristics can be found on the company web site at [www.pericom.com/packaging/](http://www.pericom.com/packaging/)