

3.3V, 7-Channel Analog Video Switch with Dual Control Logic
Features

- Designed specifically to switch VGA signals
- 7-Channels for VGA signals (R,G,B, Hsync, Vsync, DDC Dat, and DDC CLK)
- 1st SEL can control RGBHV signals and 2nd SEL can control SCL/SDA signals
- $V_{DD} = 3.3V \pm 10\%$
- ESD tolerance on video I/O pins is up to 12kV HBM per JEDEC standard and 8kV contact per IEC61000-4-2 standard
- -3dB BW of 1.0GHz (typ)
- Low Xtalk, (-44dB typ)
- Low and Flat ON-STATE resistance ($R_{on} = 3\text{-Ohm}$, $R_{on}(\text{Flat}) = 0.5\text{ohm}$, typ)
- Low input/output capacitance ($C_{in} = 6.5\text{pF}$, typ)
- Packaging (Pb-free and Green):
 - 32-contact TQFN (ZLE)
 - 28-contact TQFN (ZHE)

Applications

- Routes physical layer signals for high bandwidth digital video

Description

Pericom's PI3V712-A is a 7-channel video mux/demux used to switch between multiple VGA sources or end points. In a notebook application where analog video signals are found in both the notebook and the dock, a switch solution is required to switch between the two video port locations. With the high bandwidth of ~1.0GHz, the signal integrity will remain strong even through the long FR4 trace between the notebook and the docking station. In addition to high signal performance, the video signals are also protected against high ESD with integrated diodes to V_{DD} and GND that will support up to 8kV of contact ESD protection.

Application

Routing VGA signals with low signal attenuation and high ESD protection.

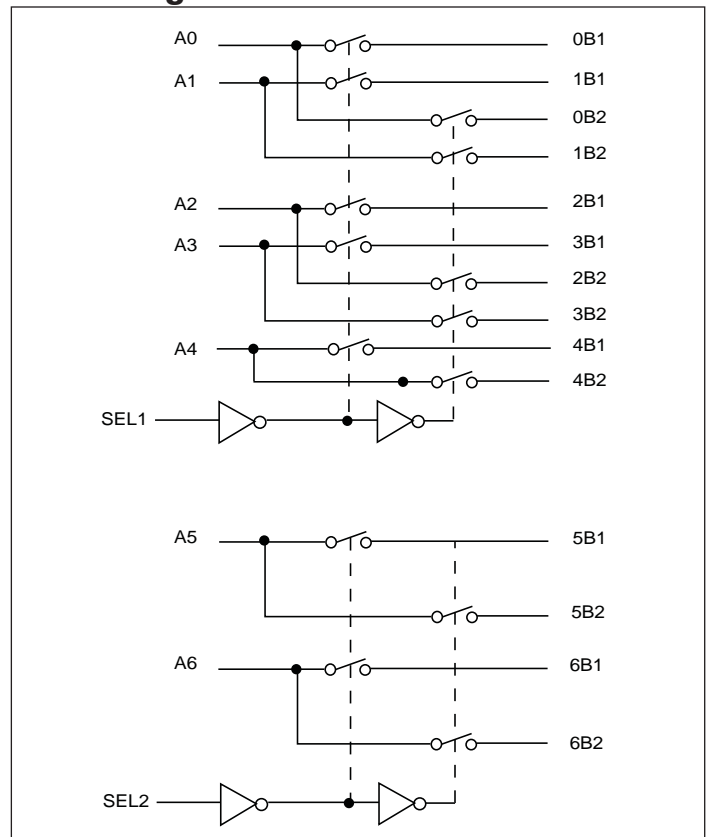
Block Diagram

Ordering Information

Ordering Code	Package Code	Package Type
PI3V712-AZHE	ZH	Pb-free & Green, 28-pin TQFN
PI3V712-AZLE	ZL	Pb-free & Green, 32-pin TQFN

1. Thermal characteristics can be found on the company web site at www.pericom.com/packaging/

2. E = Pb-free and Green

3. Adding an X Suffix = Tape/Reel

3.3V, 7-Channel Analog Video Switch with Dual Control Logic

Packaging Mechanical: 32-Pin TQFN (ZL)

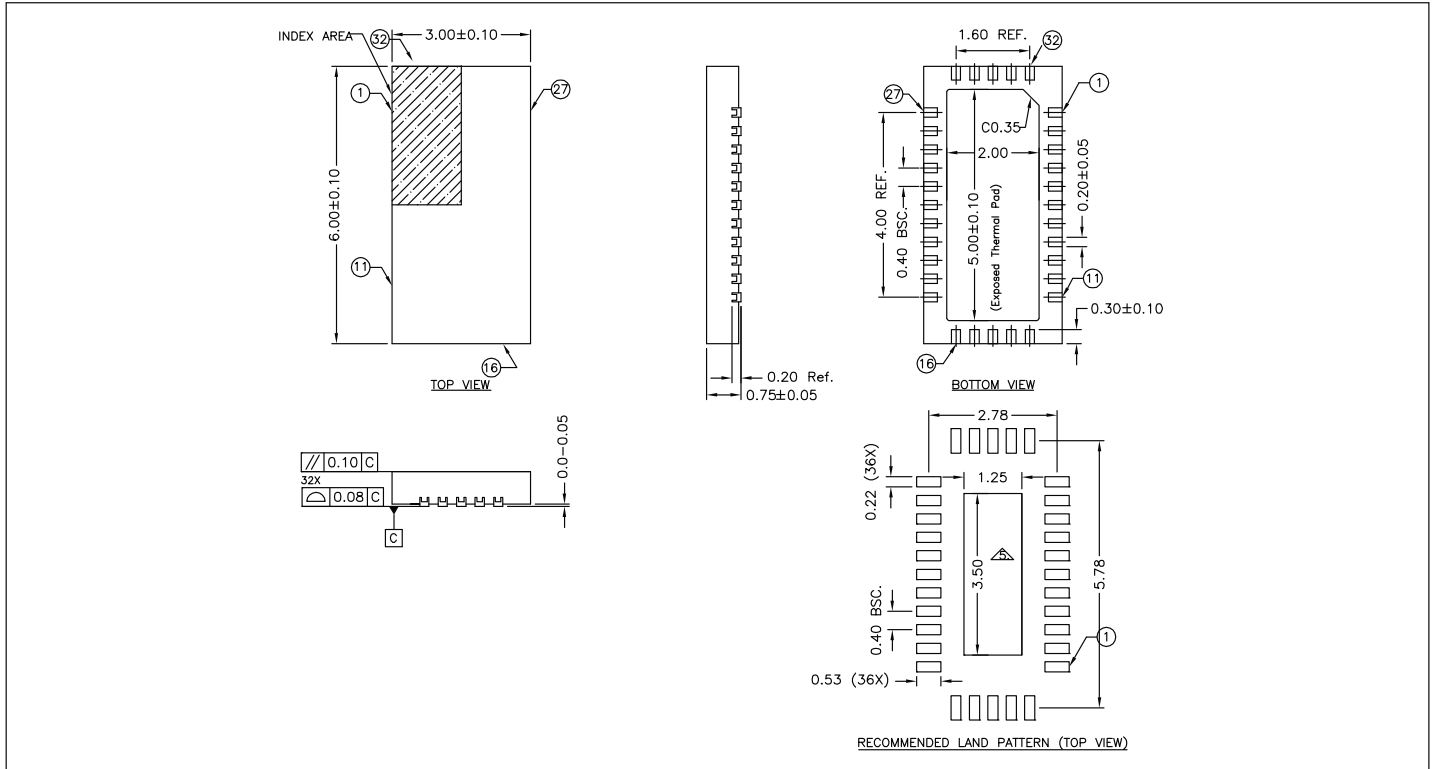

Packaging Mechanical: 28-Pin TQFN (ZH)

