



Low-Voltage, 4Ω, Quad, SPST, CMOS Analog Switches

MAX4651/MAX4652/MAX4653

General Description

The MAX4651/MAX4652/MAX4653 quad analog switches feature 4Ω max on-resistance (RON) when operating from a single +5V supply. RON is matched between switches to 0.2Ω (max) and is flat (0.8Ω max) over the specified signal range. Each switch can handle Rail-to-Rail® analog signals. Off-leakage current is 0.1nA at +25°C. These switches are ideal in low-distortion applications and are the preferred solution over mechanical relays in automated test equipment or applications where current switching is required. They have low power requirements, require less board space, and are more reliable than mechanical relays.

The MAX4651/MAX4652/MAX4653 operate from a single +1.8V to +5.5V supply, making them ideal for use in battery-powered applications.

The MAX4651 has four normally closed (NC) switches, the MAX4652 has four normally open (NO) switches, and the MAX4653 has two NO and two NC switches. These devices are available in 16-pin QFN, TSSOP and SO packages, as well as 20-pin QFN package.

Applications

- Battery-Powered Systems
- Audio and Video Signal Routing
- Low-Voltage Data-Acquisition Systems
- Sample-and-Hold Circuits
- Communications Circuits
- Relay Replacement

Rail-to-Rail is a registered trademark of Nippon Motorola, Ltd.

Pin Configurations/Functional Diagrams/Truth Tables

TOP VIEW

MAX4651	
LOGIC	SWITCH
0	ON
1	OFF

MAX4652	
LOGIC	SWITCH
0	OFF
1	ON

SWITCHES SHOWN FOR LOGIC "0" INPUT

MAX4653		
LOGIC	SWITCHES 1, 4	SWITCHES 2, 3
0	OFF	ON
1	ON	OFF

Pin Configurations continued at end of data sheet.

Features

- ◆ On-Resistance
 - 4Ω max at 5V
 - 7Ω max at 3V
- ◆ On-Resistance Flatness
 - 0.8Ω max at 5V
 - 2.5Ω max at 3V
- ◆ On-Resistance Matching
 - 0.2Ω max (+2.7V to +5.5V)
- ◆ +1.8V to +5.5V Single-Supply Voltage
- ◆ +1.8V Operation
 - On-Resistance 30Ω (typ) Over Temperature
 - tON 20ns typ, tOFF 12ns (typ)
- ◆ TTL/CMOS-Logic Compatible
- ◆ Crosstalk
 - 100dB at 1MHz
- ◆ Off-Isolation
 - 75dB at 1MHz
- ◆ Rail-to-Rail Signal Range

Ordering Information

PART	TEMP RANGE	PIN-PACKAGE
MAX4651EGE	-40°C to +85°C	16 QFN (4 × 4)
MAX4651EUE	-40°C to +85°C	16 TSSOP
MAX4651ESE	-40°C to +85°C	16 SO
MAX4651EGP	-40°C to +85°C	20 QFN (4 × 4)

Ordering Information continued at end of data sheet.



For pricing, delivery, and ordering information, please contact Maxim/Dallas Direct! at 1-888-629-4642, or visit Maxim's website at www.maxim-ic.com.

Low-Voltage, 4Ω, Quad, SPST, CMOS Analog Switches

ABSOLUTE MAXIMUM RATINGS

V+ to GND-0.3 to +6V
 IN_, COM_, NO_, NC_ to GND (Note 1).....-0.3V to (V+ + 0.3V)
 Continuous Current (NO_, NC_, COM_).....±50mA
 Peak Current (NO_, NC_, COM_, pulsed at 1ms
 10% duty cycle).....±100mA

Continuous Power Dissipation (T_A = +70°C)
 16-Pin QFN (derate 18.5mW/°C above +70°C)1481mW
 16-Pin TSSOP (derate 5.7mW/°C above +70°C)457mW
 16-Pin SO (derate 8mW/°C above +70°C).....640mW
 20-Pin QFN (derate 20mW/°C above +70°C)1600mW
 Operating Temperature Range-40°C to +85°C
 Storage Temperature Range-65°C to +150°C
 Lead Temperature (soldering, 10s)+300°C

Note 1: Signals on NO_, NC_, COM_, or IN_ exceeding V+ or GND are clamped by internal diodes. Limit forward current to maximum current rating.

Stresses beyond those listed under "Absolute Maximum Ratings" may cause permanent damage to the device. These are stress ratings only, and functional operation of the device at these or any other conditions beyond those indicated in the operational sections of the specifications is not implied. Exposure to absolute maximum rating conditions for extended periods may affect device reliability.

ELECTRICAL CHARACTERISTICS—Single +5V Supply

(V+ = 4.5V to 5.5V, V_{IH} = 2.4V, V_{IL} = 0.8V, T_A = T_{MIN} to T_{MAX}, unless otherwise specified. Typical values are at V+ = 5V, T_A = +25°C.) (Note 2)

PARAMETER	SYMBOL	CONDITIONS	MIN	TYP	MAX	UNITS	
ANALOG SWITCH							
Input Voltage Range	V _{COM_} , V _{NO_} , V _{NC_}		0		V+	V	
COM_ to NO_ or NC_ On-Resistance	R _{ON}	I _{COM} = 10mA, V _{NO_} or V _{NC_} = 0 to V+, V+ = 4.5V		2.5	4	Ω	
		T _A = T _{MIN} to T _{MAX}			4.5		
COM_ to NO_ or NC_ On-Resistance Match Between Channels (Notes 3, 8)	ΔR _{ON}	I _{COM} = 10mA, V _{NO_} or V _{NC_} = 0 to V+, V+ = 4.5V		0.05	0.2	Ω	
		T _A = T _{MIN} to T _{MAX}			0.3		
On-Resistance Flatness (Note 4)	R _{FLAT(ON)}	I _{COM} = 10mA, V _{NO_} or V _{NC_} = 0 to V+, V+ = 4.5V		0.5	0.8	Ω	
		T _A = T _{MIN} to T _{MAX}			1		
Off-Leakage Current (NO_ or NC_) (Note 5)	I _{NO_} , I _{NC_}	V _{COM} = 1V, 4.5V; V _{NO_} or V _{NC_} = 4.5V, 1V; V+ = 5.5V		-0.1	0.01	0.1	nA
		T _A = T _{MIN} to T _{MAX}		-0.2		0.2	
COM_ Off-Leakage Current (Note 5)	I _{COM(OFF)}	V _{COM} = 1V, 4.5V; V _{NO_} or V _{NC_} = 4.5V, 1V; V+ = 5.5V		-0.1	0.01	0.1	nA
		T _A = T _{MIN} to T _{MAX}		-0.2		0.2	
COM_ On-Leakage Current (Note 5)	I _{COM(ON)}	V+ = 5.5V, V _{COM} = 1V, 4.5V; V _{NO_} or V _{NC_} = 1V, 4.5V or floating		-0.1	0.01	0.1	nA
		T _A = T _{MIN} to T _{MAX}		-0.2		0.2	
LOGIC INPUT (IN_)							
Input High	V _{IH}		2.4			V	
Input Low	V _{IL}				0.8	V	
Logic Input Current	I _{IN}		-100	5	100	nA	

Low-Voltage, 4Ω, Quad, SPST, CMOS Analog Switches

MAX4651/MAX4652/MAX4653

ELECTRICAL CHARACTERISTICS—Single +5V Supply (continued)

(V+ = 4.5V to 5.5V, V_{IH} = 2.4V, V_{IL} = 0.8V, T_A = T_{MIN} to T_{MAX}, unless otherwise specified. Typical values are at V+ = 5V, T_A = +25°C.) (Note 2)

PARAMETER	SYMBOL	CONDITIONS	MIN	TYP	MAX	UNITS
SWITCH DYNAMIC CHARACTERISTICS						
Turn-On Time (Note 5)	t _{ON}	V _{NO_} = V _{NC_} = 3V, R _L = 300Ω, C _L = 35pF, Figure 2	T _A = +25°C	11	14	ns
			T _A = T _{MIN} to T _{MAX}		16	
Turn-Off Time (Note 5)	t _{OFF}	V _{NO_} = V _{NC_} = 3V, R _L = 300Ω, C _L = 35pF, Figure 2	T _A = +25°C	6	8	ns
			T _A = T _{MIN} to T _{MAX}		10	
Break-Before-Make (MAX4653 only) (Note 5)		V _{NO_} = V _{NC_} = 3V, R _L = 300Ω, C _L = 35pF	T _A = +25°C	1	6	ns
			T _A = T _{MIN} to T _{MAX}	1		
Charge Injection	Q	V _{GEN} = 2V, C _L = 1.0nF, R _{GEN} = 0, Figure 3		2		pC
NO_ or NC_ Off-Capacitance	C _{OFF}	V _{NO_} = V _{NC_} = GND, f = 1MHz, Figure 6		16		pF
COM_ Off-Capacitance	C _{COM(OFF)}	V _{COM_} = GND, f = 1MHz, Figure 6		16		pF
COM_ On-Capacitance	C _{COM(ON)}	V _{COM_} = V _{NO_} , V _{NC_} = GND, f = 1MHz, Figure 7		32		pF
Off-Isolation (Note 6)	V _{ISO}	R _L = 50Ω, C _L = 5pF, f = 10MHz, Figure 4		-50		dB
		R _L = 50Ω, C _L = 5pF, f = 1MHz, Figure 4		-75		
Crosstalk (Note 7)	V _{CT}	R _L = 50Ω, C _L = 5pF, f = 10MHz, Figure 5		-80		dB
		R _L = 50Ω, C _L = 5pF, f = 1MHz, Figure 5		-100		
Total Harmonic Distortion	THD	R _L = 600Ω, f = 20Hz to 20kHz		0.02		%
POWER SUPPLY						
Positive Supply Current	I ₊	V+ = 5.5V, V _{IN} = 0 or V+		0.001	1.0	μA

ELECTRICAL CHARACTERISTICS—Single +3V Supply

(V+ = 2.7V to 3.3V, V_{IH} = 2.0V, V_{IL} = 0.4V, T_A = T_{MIN} to T_{MAX}, unless otherwise specified. Typical values are at V+ = 3V, T_A = +25°C.) (Note 2)

PARAMETER	SYMBOL	CONDITIONS	MIN	TYP	MAX	UNITS
ANALOG SWITCH						
Input Voltage Range	V _{COM_} , V _{NO_} , V _{NC_}		0		V+	V
COM_ to NO_ or NC_ On-Resistance	R _{ON}	V+ = 2.7V, I _{COM} = 10mA, V _{NO_} or V _{NC_} = 0 to V+	T _A = +25°C	5	7	Ω
			T _A = T _{MIN} to T _{MAX}		8	
COM_ to NO_ or NC_ On-Resistance Match Between Channels (Notes 3, 8)	ΔR _{ON}	V+ = 2.7V, I _{COM} = 10mA, V _{NO_} or V _{NC_} = 0 to V+	T _A = +25°C	0.1	0.2	Ω
			T _A = T _{MIN} to T _{MAX}		0.3	
On-Resistance Flatness (Note 4)	R _{FLAT(ON)}	V+ = 2.7V, I _{COM} = 10mA, V _{NO_} or V _{NC_} = 0 to V+	T _A = +25°C	1.2	2.5	Ω
			T _A = T _{MIN} to T _{MAX}		3	

Low-Voltage, 4Ω, Quad, SPST, CMOS Analog Switches

ELECTRICAL CHARACTERISTICS—Single +3V Supply (continued)

(V+ = 2.7V to 3.3V, V_{IH} = 2.0V, V_{IL} = 0.4V, T_A = T_{MIN} to T_{MAX}, unless otherwise specified. Typical values are at V+ = 3V, T_A = +25°C.) (Note 2)

PARAMETER	SYMBOL	CONDITIONS	MIN	TYP	MAX	UNITS
LOGIC INPUT (IN₋)						
Input High	V _{IH}		2.0			V
Input Low	V _{IL}				0.4	V
Logic Input Current	I _{IN}		-100	5	100	nA
SWITCH DYNAMIC CHARACTERISTICS						
Turn-On Time (Note 5)	t _{ON}	V _{NO₋} = V _{NC₋} = 2V, R _L = 300Ω, C _L = 35pF, Figure 2	T _A = +25°C	13	16	ns
			T _A = T _{MIN} to T _{MAX}		20	
Turn-Off Time (Note 5)	t _{OFF}	V _{NO₋} = V _{NC₋} = 2V, R _L = 300Ω, C _L = 35pF, Figure 2	T _A = +25°C	7	10	ns
			T _A = T _{MIN} to T _{MAX}		12	
Break-Before-Make (MAX4653 only) (Note 5)		V _{NO₋} = V _{NC₋} = 2V, R _L = 300Ω, C _L = 35pF	T _A = +25°C	1	7	ns
			T _A = T _{MIN} to T _{MAX}	1		
Charge Injection	Q	V _{GEN} = 1.5V, C _L = 1.0nF, R _{GEN} = 0, Figure 3		2		pC
NO ₋ or NC ₋ Off-Capacitance	C _{OFF}	V _{NO₋} = V _{NC₋} = GND, f = 1MHz, Figure 6		16		pF
COM ₋ Off-Capacitance	C _{COM(OFF)}	V _{COM₋} = GND, f = 1MHz, Figure 6		16		pF
COM ₋ On-Capacitance	C _{COM(ON)}	V _{COM₋} = V _{NO₋} , V _{NC₋} = GND, f = 1MHz, Figure 7		32		pF
Off-Isolation (Note 6)	V _{ISO}	R _L = 50Ω, C _L = 5pF, f = 10MHz, Figure 4		-50		dB
			R _L = 50Ω, C _L = 5pF, f = 1MHz, Figure 4		-75	
Crosstalk (Note 7)	V _{CT}	R _L = 50Ω, C _L = 5pF, f = 10MHz, Figure 5		-80		dB
			R _L = 50Ω, C _L = 5pF, f = 1MHz, Figure 5		-100	
Total Harmonic Distortion	THD	R _L = 600Ω, f = 20Hz to 20kHz		0.02		%
POWER SUPPLY						
Positive Supply Current	I+	V+ = 3.3V, V _{IN} = 0 or V+		0.001	1.0	μA

Note 2: The algebraic convention, where the most negative value is a minimum and the most positive value is a maximum, is used in this data sheet.

Note 3: $\Delta R_{ON} = R_{ON(MAX)} - R_{ON(MIN)}$.

Note 4: Flatness is defined as the difference between the maximum and the minimum value of on-resistance as measured over the specified analog signal ranges.

Note 5: Guaranteed by design.

Note 6: Off-Isolation = $20 \log_{10}(V_{COM} / V_{NO})$, where V_{COM} = output and V_{NO} = input to off switch.

Note 7: Between any two switches.

Note 8: ΔR_{ON} matching specifications for QFN-packages parts are guaranteed by design.

Low-Voltage, 4Ω, Quad, SPST, CMOS Analog Switches

Typical Operating Characteristics

(V+ = 5V, TA = +25°C, unless otherwise noted.)

MAX4651/MAX4652/MAX4653

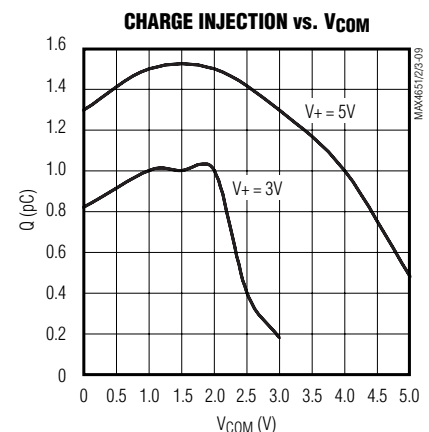
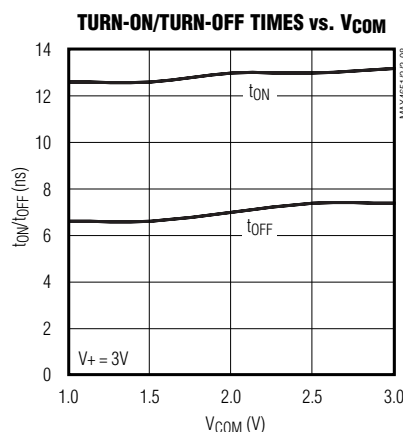
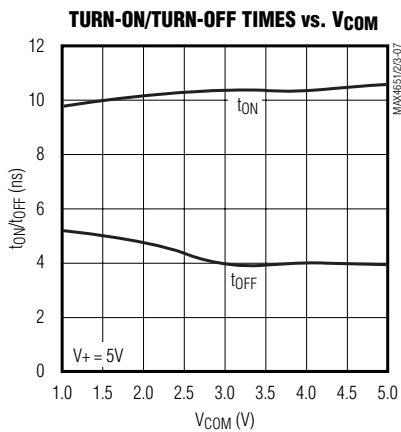
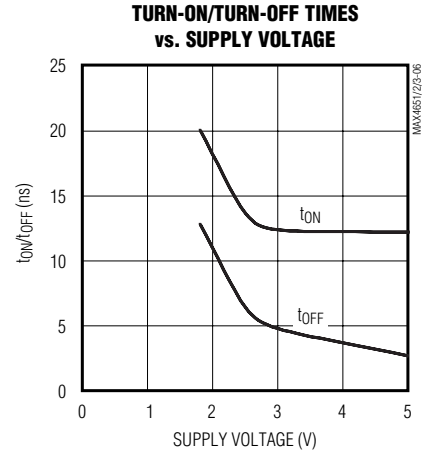
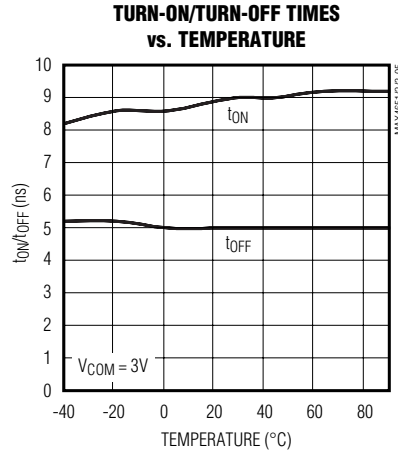
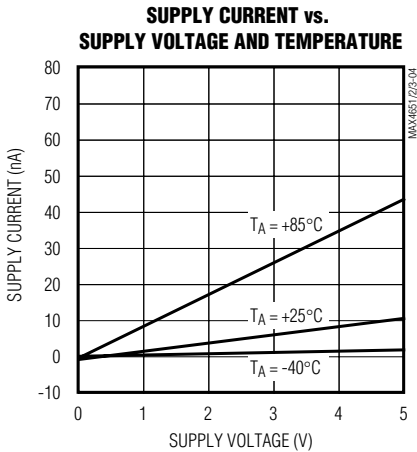
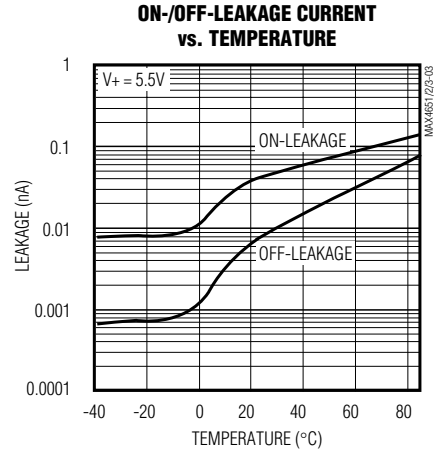
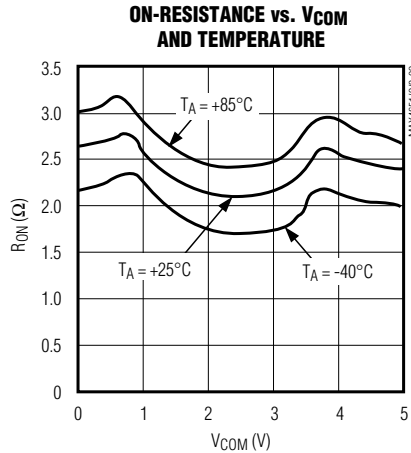
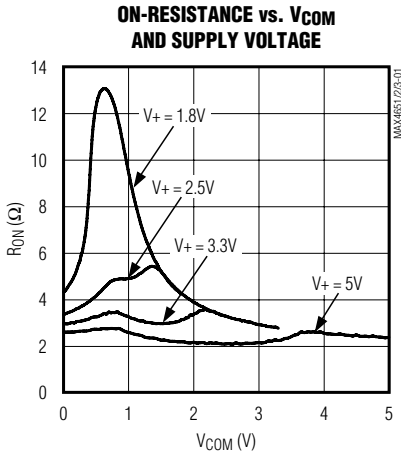

Low-Voltage, 4Ω, Quad, SPST, CMOS Analog Switches

Typical Operating Characteristics (continued)

(V+ = 5V, TA = +25°C, unless otherwise noted.)

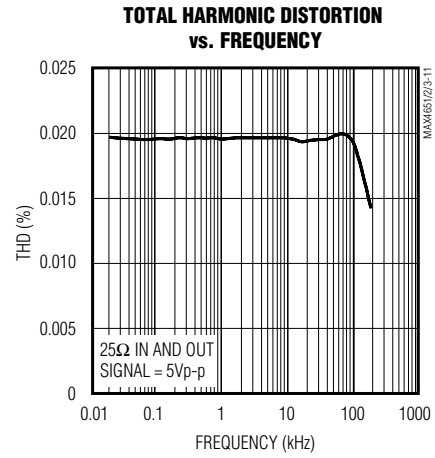
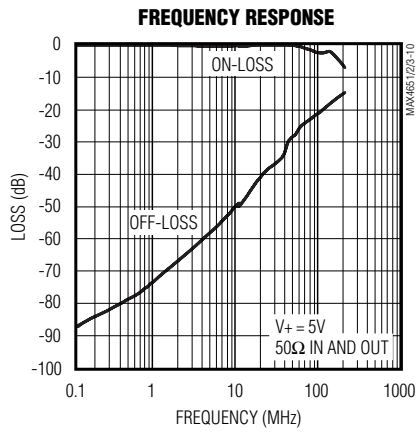

Low-Voltage, 4Ω, Quad, SPST, CMOS Analog Switches

Pin Description

MAX4651/MAX4652/MAX4653

PIN									NAME	FUNCTION
MAX4651			MAX4652			MAX4653				
TSSOP/ SO	16-PIN QFN	20-PIN QFN	TSSOP/ SO	16-PIN QFN	20-PIN QFN	TSSOP/ SO	16-PIN QFN	20-PIN QFN		
1	15	19	1	15	19	1	15	19	IN1	Digital Control Input 1
2	16	1	2	16	1	2	16	1	COM1	Analog Switch 1 Common Terminal
3	1	2	—	—	—	—	—	—	NC1	Analog Switch 1 Normally Closed Terminal
—	—	—	3	1	2	3	1	2	NO1	Analog Switch 1 Normally Open Terminal
4, 12	2, 10	6, 8, 10, 16, 18, 20	4, 12	2, 10	6, 8, 10, 16, 18, 20	4, 12	2, 10	6, 8, 10, 16, 18, 20	N.C.	No Connection. Not internally connected.
5	3	3	5	3	3	5	3	3	GND	Ground
6	4	4	—	—	—	—	—	—	NC4	Analog Switch 4 Normally Closed Terminal
—	—	—	6	4	4	6	4	4	NO4	Analog Switch 4 Normally Open Terminal
7	5	5	7	5	5	7	5	5	COM4	Analog Switch 4 Common Terminal
8	6	7	8	6	7	8	6	7	IN4	Digital Control Input 4
9	7	9	9	7	9	9	7	9	IN3	Digital Control Input 3
10	8	11	10	8	11	10	8	11	COM3	Analog Switch 3 Common Terminal
11	9	12	—	—	—	11	9	12	NC3	Analog Switch 3 Normally Closed Terminal
—	—	—	11	9	12	—	—	—	NO3	Analog Switch 3 Normally Open Terminal
13	11	13	13	11	13	13	11	13	V+	Positive-Supply Voltage Input
14	12	14	—	—	—	14	12	14	NC2	Analog Switch 2 Normally Closed Terminal
—	—	—	14	12	14	—	—	—	NO2	Analog Switch 2 Normally Open Terminal
15	13	15	15	13	15	15	13	15	COM2	Analog Switch 2 Common Terminal
16	14	17	16	14	17	16	14	17	IN2	Digital Control Input 2

Low-Voltage, 4Ω , Quad, SPST, CMOS Analog Switches

Detailed Description

The MAX4651/MAX4652/MAX4653 are low on-resistance, low-voltage analog switches that operate from a single +1.8V to +5.5V supply. CMOS switch construction allows processing analog signals that are within the supply voltage range (GND to $V+$).

Applications Information

Proper power-supply sequencing is recommended for all CMOS devices. Do not exceed the absolute maximum ratings because stresses beyond the listed ratings can cause permanent damage to the devices. Always sequence $V+$ on first, followed by the logic inputs, NO or COM. If power-supply sequencing is not possible, add two small signal diodes (D1, D2) in series with the supply pins for overvoltage protection (Figure 1). Adding these diodes reduces the analog signal by one diode drop below $V+$ and one diode drop above GND, but does not affect the devices' low switch resistance and low leakage characteristics. Device operation is unchanged, and the difference between $V+$ and GND should not exceed 6V.

Although it is not required, power-supply bypassing improves noise margin and prevents switching noise from propagating from the $V+$ supply to other components. A 0.1 μ F capacitor connected from $V+$ to GND is adequate for most applications.

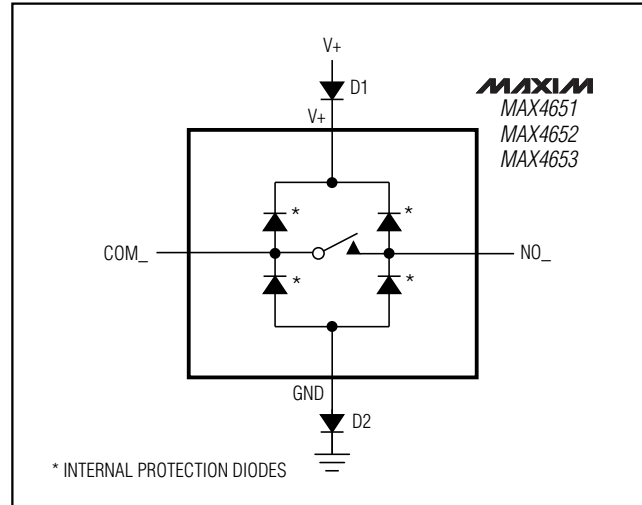

Figure 1. Overvoltage Protection Using External Blocking Diodes

Chip Information

TRANSISTOR COUNT: 205

Low-Voltage, 4Ω, Quad, SPST, CMOS Analog Switches

Timing Diagrams/Test Circuits

MAX4651/MAX4652/MAX4653

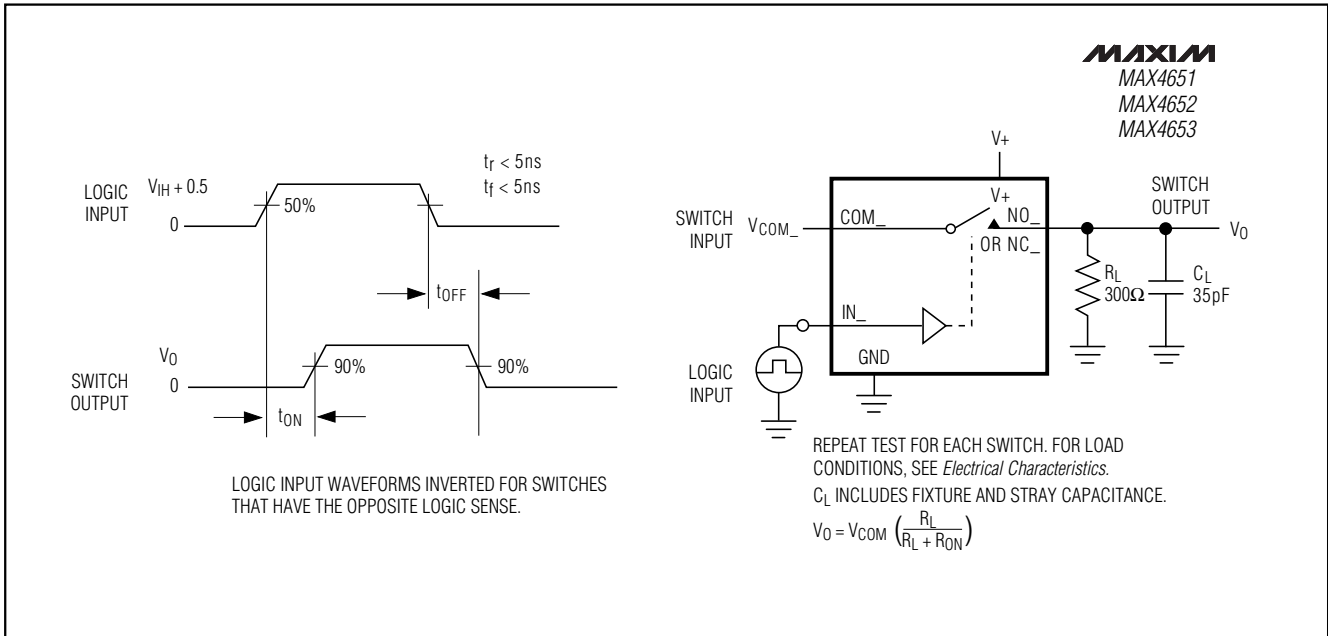

Figure 2. Switching-Time Test Circuit

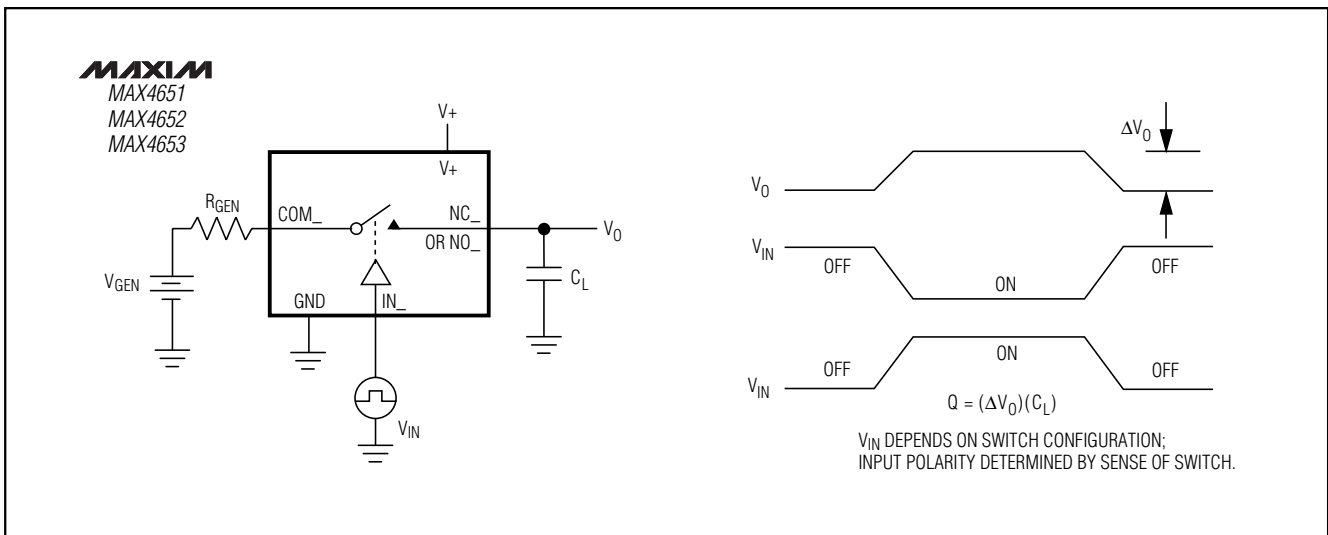

Figure 3. Charge-Injection Test Circuit

Low-Voltage, 4Ω, Quad, SPST, CMOS Analog Switches

Timing Diagrams/Test Circuits (continued)

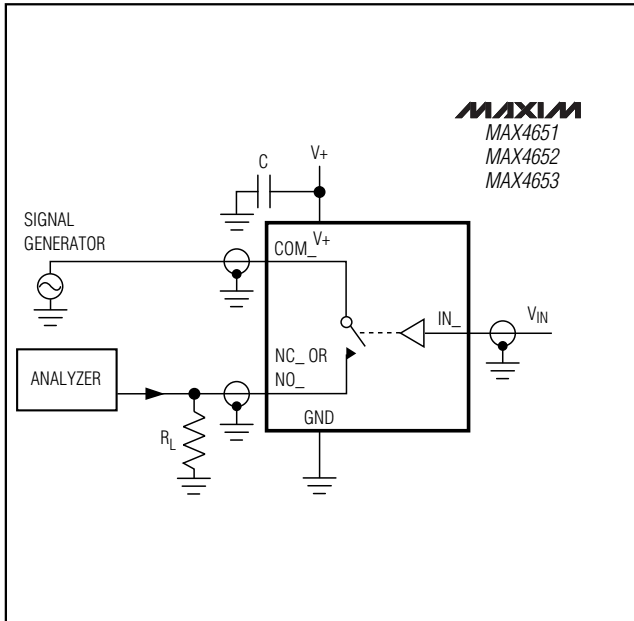

Figure 4. Off-Isolation Test Circuit/On-Channel Bandwidth

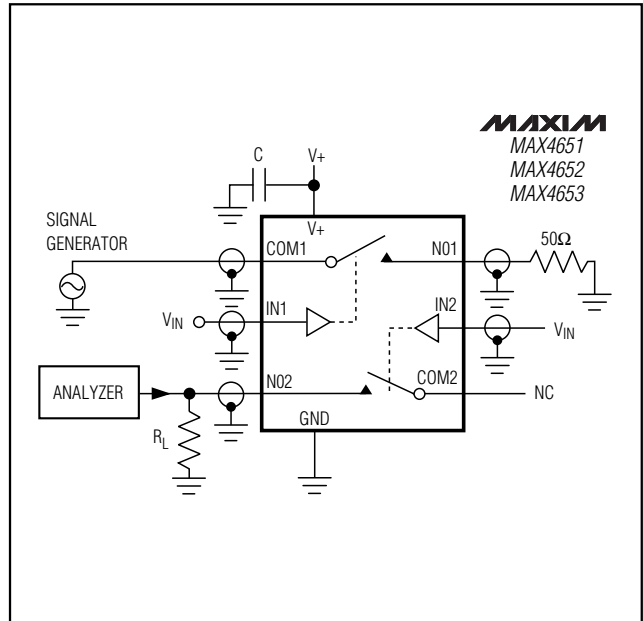

Figure 5. Crosstalk Test Circuit

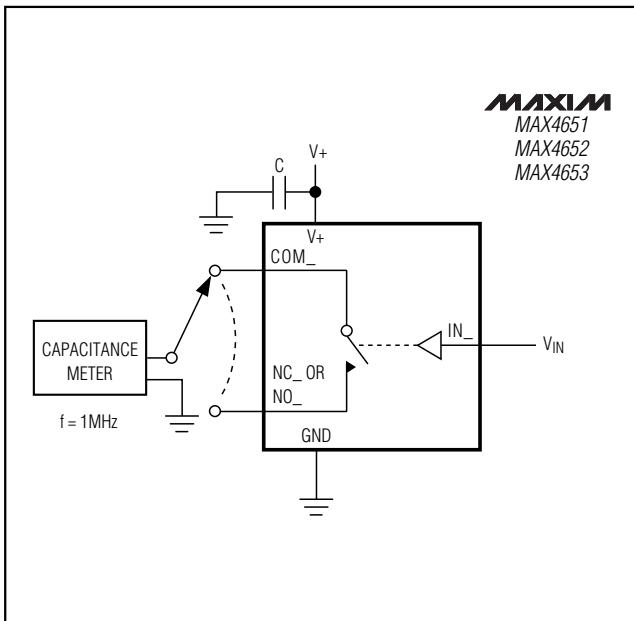

Figure 6. Switch Off-Capacitance Test Circuit

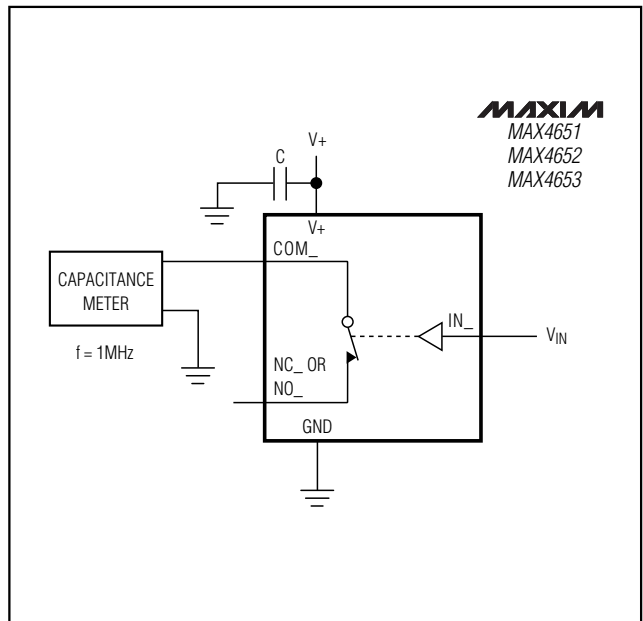
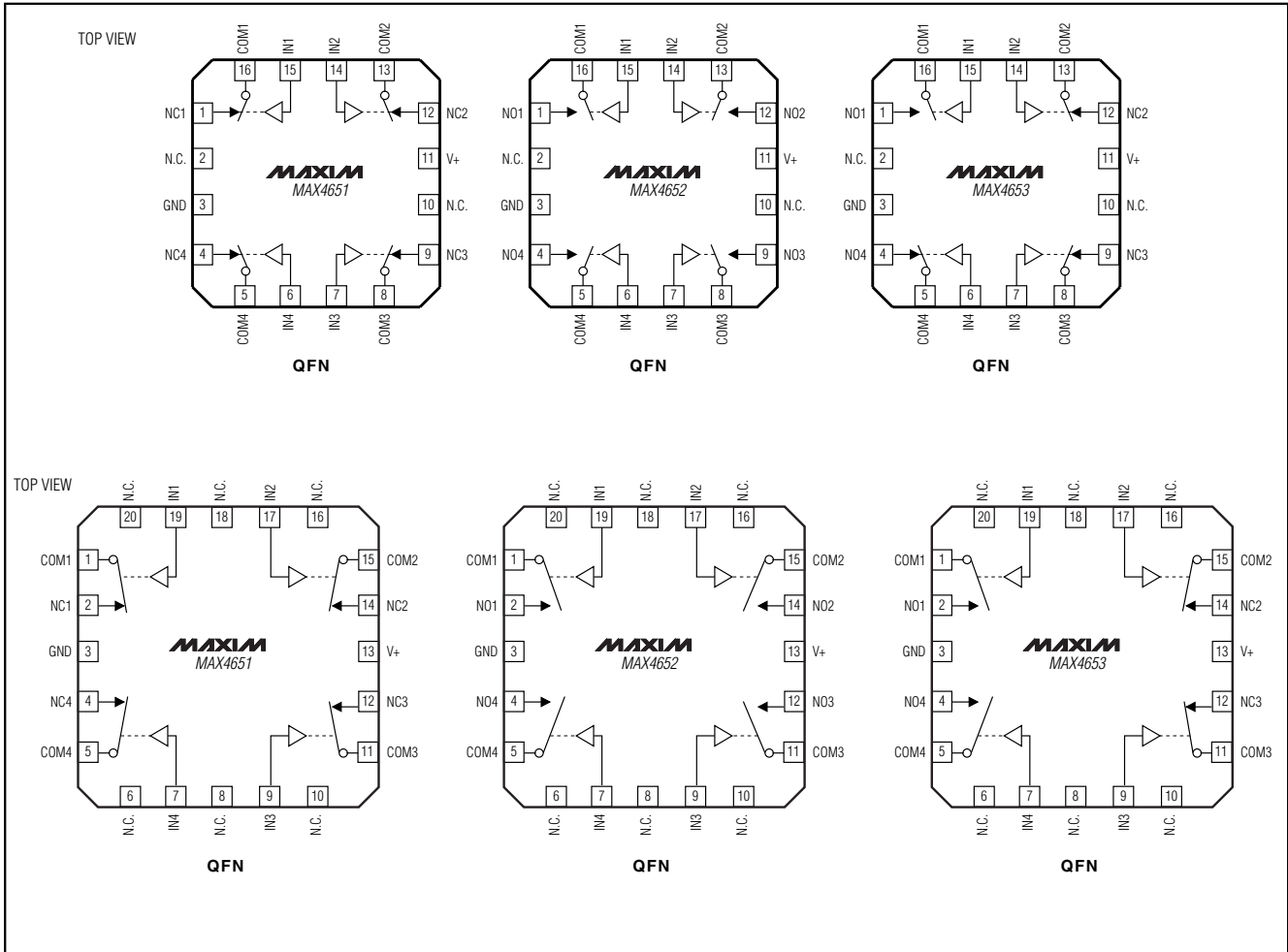

Figure 7. Switch On-Capacitance Test Circuit

Low-Voltage, 4Ω, Quad, SPST, CMOS Analog Switches

Pin Configurations (continued)

MAX4651/MAX4652/MAX4653



Ordering Information (continued)

PART	TEMP RANGE	PIN-PACKAGE
MAX4652 EGE	-40°C to +85°C	16 QFN (4 × 4)
MAX4652EUE	-40°C to +85°C	16 TSSOP
MAX4652ESE	-40°C to +85°C	16 SO
MAX4652EGP	-40°C to +85°C	20 QFN (4 × 4)
MAX4653 EGE	-40°C to +85°C	16 QFN (4 × 4)
MAX4653EUE	-40°C to +85°C	16 TSSOP
MAX4653ESE	-40°C to +85°C	16 SO
MAX4653EGP	-40°C to +85°C	20 QFN (4 × 4)

Low-Voltage, 4Ω, Quad, SPST, CMOS Analog Switches

Package Information

(The package drawing(s) in this data sheet may not reflect the most current specifications. For the latest package outline information, go to www.maxim-ic.com/packages.)

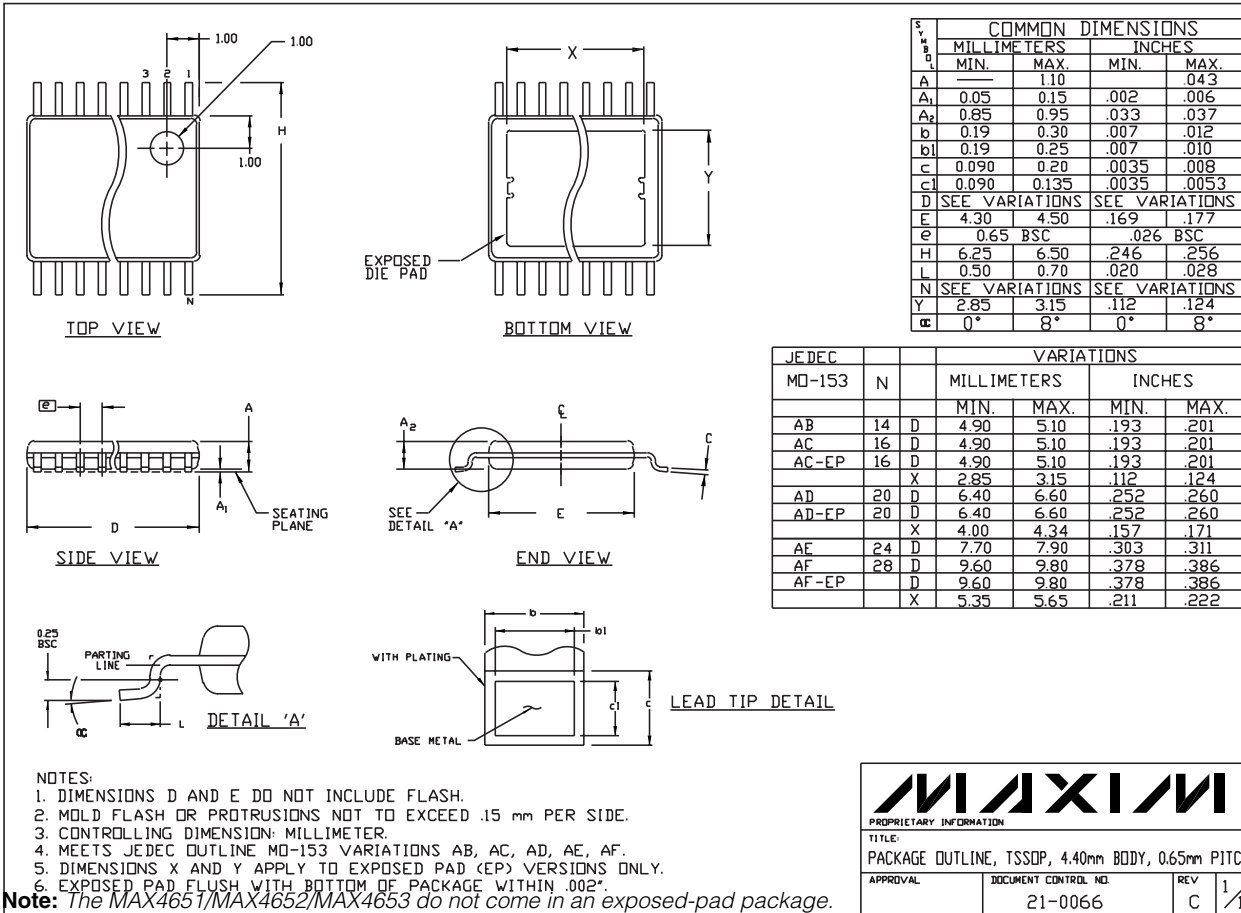

TSSOPERS

PROPRIETARY INFORMATION

TITLE:
PACKAGE OUTLINE, TSSOP, 4.40mm BODY, 0.65mm PITCH

APPROVAL	DOCUMENT CONTROL NO.	REV	1/1
	21-0066	C	

Low-Voltage, 4Ω, Quad, SPST, CMOS Analog Switches

Package Information (continued)

(The package drawing(s) in this data sheet may not reflect the most current specifications. For the latest package outline information, go to www.maxim-ic.com/packages.)

MAX4651/MAX4652/MAX4653

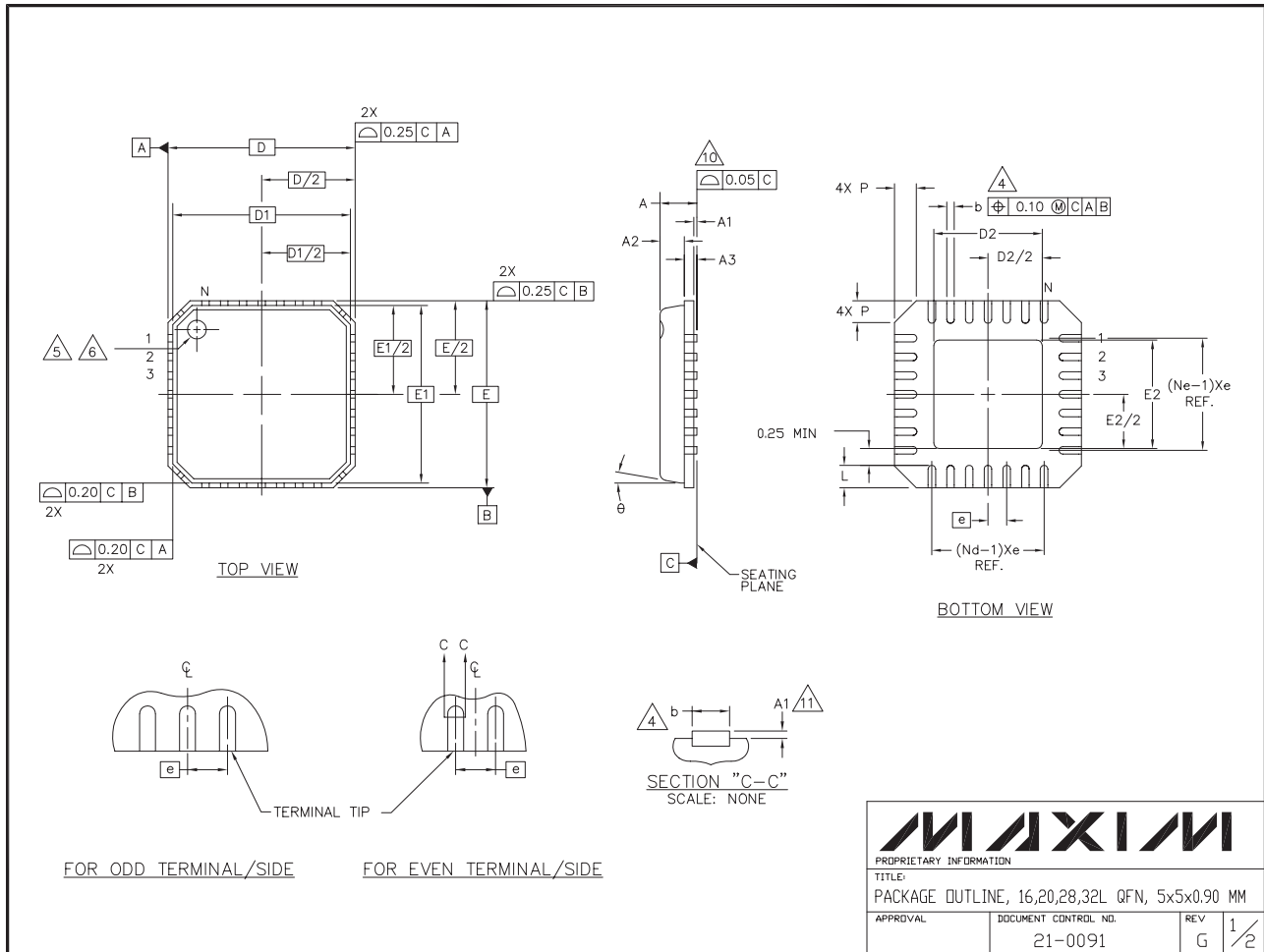

Low-Voltage, 4Ω, Quad, SPST, CMOS Analog Switches

Package Information (continued)

(The package drawing(s) in this data sheet may not reflect the most current specifications. For the latest package outline information, go to www.maxim-ic.com/packages.)

NOTES:

1. DIE THICKNESS ALLOWABLE IS 0.305mm MAXIMUM (.012 INCHES MAXIMUM)
2. DIMENSIONING & TOLERANCES CONFORM TO ASME Y14.5M. - 1994.
3. N IS THE NUMBER OF TERMINALS.
Nd IS THE NUMBER OF TERMINALS IN X-DIRECTION &
Ne IS THE NUMBER OF TERMINALS IN Y-DIRECTION.
4. DIMENSION b APPLIES TO PLATED TERMINAL AND IS MEASURED BETWEEN 0.20 AND 0.25mm FROM TERMINAL TIP.
5. THE PIN #1 IDENTIFIER MUST BE EXISTED ON THE TOP SURFACE OF THE PACKAGE BY USING INDENTATION MARK OR INK/ LASER MARKED.
6. EXACT SHAPE AND SIZE OF THIS FEATURE IS OPTIONAL.
7. ALL DIMENSIONS ARE IN MILLIMETERS.
8. PACKAGE WARPAGE MAX 0.05mm.
9. APPLIED FOR EXPOSED PAD AND TERMINALS.
EXCLUDE EMBEDDED PART OF EXPOSED PAD FROM MEASURING.
10. MEETS JEDEC M0220.
11. THIS PACKAGE OUTLINE APPLIES TO ANVIL SINGULATION (STEPPED SIDES) AND TO SAW SINGULATION (STRAIGHT SIDES) QFN STYLES.

SYMBOL	COMMON DIMENSIONS			NOTE
	MIN.	NOM.	MAX.	
A	0.80	0.90	1.00	
A1	0.00	0.01	0.05	
A2	0.00	0.65	1.00	
A3	0.20 REF.			
D	5.00 BSC			
D1	4.75 BSC			
E	5.00 BSC			
E1	4.75 BSC			
θ	0°	-	12°	
P	0	-	0.60	
D2	1.25	-	3.25	
E2	1.25	-	3.25	

SYMBOL	PITCH VARIATION B			NOTE	SYMBOL	PITCH VARIATION B			NOTE	SYMBOL	PITCH VARIATION C			NOTE	SYMBOL	PITCH VARIATION D			NOTE
	MIN.	NOM.	MAX.			MIN.	NOM.	MAX.			MIN.	NOM.	MAX.			MIN.	NOM.	MAX.	
Ⓢ	0.80 BSC				Ⓢ	0.65 BSC				Ⓢ	0.50 BSC				Ⓢ	0.50 BSC			
N	16			3	N	20			3	N	28			3	N	32			3
Nd	4			3	Nd	5			3	Nd	7			3	Nd	8			3
Ne	4			3	Ne	5			3	Ne	7			3	Ne	8			3
L	0.35	0.55	0.75		L	0.35	0.55	0.75		L	0.35	0.55	0.75		L	0.30	0.40	0.50	
b	0.28	0.33	0.40	4	b	0.23	0.28	0.35	4	b	0.18	0.23	0.30	4	b	0.18	0.23	0.30	4



PROPRIETARY INFORMATION

TITLE:
PACKAGE OUTLINE, 16,20,28,32L QFN, 5x5x0.90 MM

APPROVAL	DOCUMENT CONTROL NO. 21-0091	REV G	2/2
----------	---------------------------------	----------	-----

Low-Voltage, 4Ω, Quad, SPST, CMOS Analog Switches

Package Information (continued)

(The package drawing(s) in this data sheet may not reflect the most current specifications. For the latest package outline information, go to www.maxim-ic.com/packages.)

MAX4651/MAX4652/MAX4653

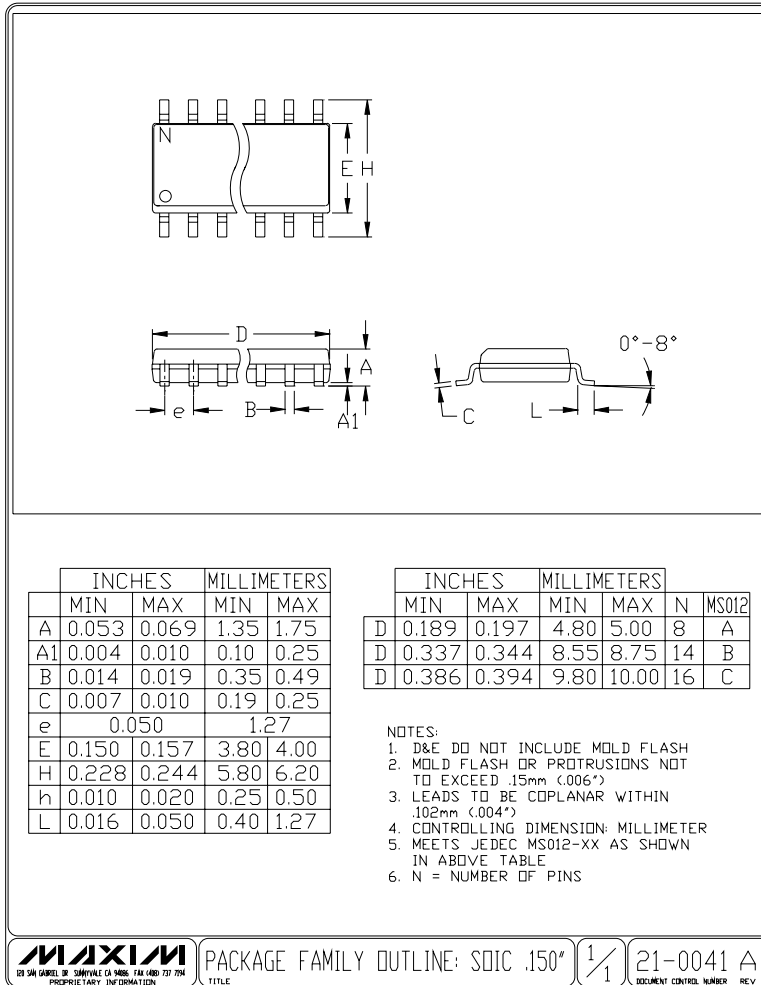

Maxim cannot assume responsibility for use of any circuitry other than circuitry entirely embodied in a Maxim product. No circuit patent licenses are implied. Maxim reserves the right to change the circuitry and specifications without notice at any time.

Maxim Integrated Products, 120 San Gabriel Drive, Sunnyvale, CA 94086 408-737-7600 _____ 15

© 2002 Maxim Integrated Products

Printed USA

MAXIM is a registered trademark of Maxim Integrated Products.