



Low-Voltage, Dual-Supply, SPDT Analog Switch with Enable

MAX4564

General Description

The MAX4564 is a low-voltage, dual-supply, single-pole/double-throw (SPDT) analog switch designed to operate from dual $\pm 1.8\text{V}$ to $\pm 6\text{V}$ or single $+1.8\text{V}$ to $+12\text{V}$ supplies. The low on-resistance ($R_{ON} = 40\Omega$ at $\pm 5\text{V}$) and low power consumption ($5\mu\text{W}$) make this part ideal for audio, video, and battery-powered applications. This switch offers low leakage currents (1nA max) and fast switching speeds ($t_{ON} = 60\text{ns}$ and $t_{OFF} = 40\text{ns}$ at $\pm 5\text{V}$, max).

The MAX4564 is available in 8-pin SOT23 and μMAX packages.

Applications

- Battery-Operated Systems
- Audio and Video Switching
- Test Equipment
- Communications Circuits
- Sample-and-Hold Circuits
- Communications Systems

Features

- ◆ 60Ω max (40Ω , typ) On-Resistance (R_{ON})
- ◆ 3Ω max (0.75Ω , typ) R_{ON} Matching Between Channels
- ◆ 10Ω (max) R_{ON} Flatness
- ◆ Low Charge Injection: 3pC (typ)
- ◆ Low $\pm 1\text{nA}$ Leakage Current at $+25^\circ\text{C}$
- ◆ Fast Switching
 $t_{ON} = 60\text{ns}$ (max)
 $t_{OFF} = 40\text{ns}$ (max)
- ◆ Guaranteed Break-Before-Make Switching
- ◆ TTL/CMOS-Logic Compatible
- ◆ Low Crosstalk: -72dB (1MHz)
- ◆ High Off-Isolation: -77dB (1MHz)
- ◆ Bandwidth -3dB : $>450\text{MHz}$ (typ)
- ◆ Available in an 8-Pin SOT23 Package

Ordering Information

PART	TEMP RANGE	PIN-PACKAGE
MAX4564EKA-T	-40°C to $+85^\circ\text{C}$	8 SOT23-8
MAX4564EUA	-40°C to $+85^\circ\text{C}$	8 μMAX

Functional Diagrams/Pin Configurations/Truth Table

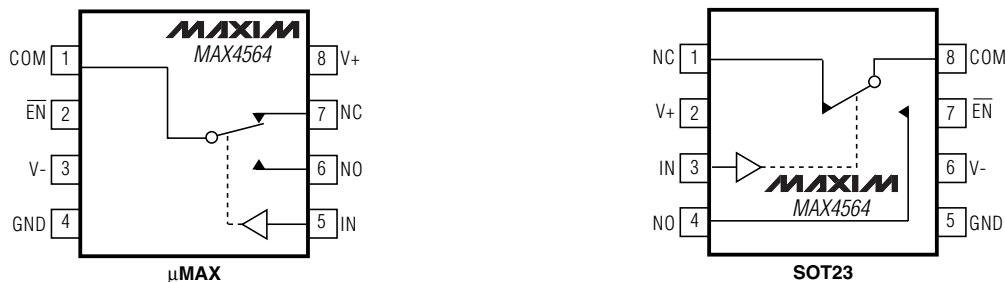

$\overline{\text{EN}}$	IN	NC	NO
0	0	ON	OFF
0	1	OFF	ON
1	X	OFF	OFF

x = Don't care



For pricing, delivery, and ordering information, please contact Maxim/Dallas Direct! at 1-888-629-4642, or visit Maxim's website at www.maxim-ic.com.

Low-Voltage, Dual-Supply, SPDT Analog Switch with Enable

ABSOLUTE MAXIMUM RATINGS

(Voltages Referenced to GND)

V+-0.3V to +13V
V--13V to +0.3V
V+ to V--0.3V to +13V
\overline{EN} , IN, COM, NC, NO (Note 1) (V- - 0.3V) to (V+ + 0.3V)
Continuous Current (any terminal) ± 20 mA
Peak Current, COM, NC, NO (pulsed at 1ms, 10% duty cycle) ± 30 mA
ESD per Method 3015.7 >2kV

Continuous Power Dissipation ($T_A = +70^\circ\text{C}$)

8-Pin SOT23 (derate 7.1mW/ $^\circ\text{C}$ above $+70^\circ\text{C}$)571mW
8-Pin μMAX (derate 4.10mW/ $^\circ\text{C}$ above $+70^\circ\text{C}$)330mW
Operating Temperature Range	
MAX4564E_A -40°C to $+85^\circ\text{C}$
Junction Temperature $+150^\circ\text{C}$
Storage Temperature Range -65°C to $+150^\circ\text{C}$
Lead Temperature (soldering, 10s) $+300^\circ\text{C}$

Note 1: Signals on NO, NC, COM, IN, or \overline{EN} exceeding V+ or V- are clamped by internal diodes. Limit forward-diode current to maximum current rating.

Stresses beyond those listed under "Absolute Maximum Ratings" may cause permanent damage to the device. These are stress ratings only, and functional operation of the device at these or any other conditions beyond those indicated in the operational sections of the specifications is not implied. Exposure to absolute maximum rating conditions for extended periods may affect device reliability.

ELECTRICAL CHARACTERISTICS— $\pm 5\text{V}$ Supply

(V+ = +4.5V to +6V, V- = -4.5V to -6V, $V_{IH} = +2.4\text{V}$, $V_{IL} = +0.8\text{V}$, GND = 0, $T_A = T_{MIN}$ to T_{MAX} , unless otherwise noted. Typical values are at $T_A = +25^\circ\text{C}$.) (Notes 2, 3)

PARAMETER	SYMBOL	CONDITIONS	T_A	MIN	TYP	MAX	UNITS
ANALOG SWITCH							
Analog Signal Range	V_{COM} , V_{NO} , V_{NC}			V-		V+	V
On-Resistance	R_{ON}	V+ = +4.5V, V- = -4.5V, $I_{COM} = 1\text{mA}$; V_{NO} , $V_{NC} = \pm 3.5\text{V}$	+25 $^\circ\text{C}$ E		40 60	60 100	Ω
On-Resistance Match Between Channels (Note 4)	ΔR_{ON}	V+ = +4.5V, V- = -4.5V, $I_{COM} = 1\text{mA}$; V_{NO} , $V_{NC} = \pm 3.5\text{V}$	+25 $^\circ\text{C}$ E		0.75	3 4	Ω
On-Resistance Flatness (Note 5)	$R_{FLAT(ON)}$	V+ = +4.5V, V- = -4.5V, $I_{COM} = 1\text{mA}$; V_{NO} , $V_{NC} = -3.5\text{V}$, 0, +3.5V	+25 $^\circ\text{C}$ E		6.5	10 13	Ω
NO or NC Off-Leakage Current	$I_{NC(OFF)}$ or $I_{NO(OFF)}$	V+ = +5.5V, V- = -5.5V; $V_{COM} = +4.5\text{V}$, -4.5V; V_{NO} , $V_{NC} = -4.5$, +4.5V	+25 $^\circ\text{C}$ E	-1	0.05	1 5	nA
COM Off-Leakage Current	$I_{COM(OFF)}$	V+ = +5.5V, V- = -5.5V; $V_{COM} = +4.5\text{V}$, -4.5V; V_{NO} , $V_{NC} = -4.5$, +4.5V	+25 $^\circ\text{C}$ E	-1	0.05	1 5	nA
COM On-Leakage Current	$I_{COM(ON)}$	V+ = +5.5V, V- = -5.5V, $V_{COM} = +4.5\text{V}$, -4.5V; V_{NO} , $V_{NC} = +4.5\text{V}$, -4.5V, or floating	+25 $^\circ\text{C}$ E	-2	0.05	2 10	nA

Low-Voltage, Dual-Supply, SPDT Analog Switch with Enable

MAX4564

ELECTRICAL CHARACTERISTICS—±5V Supply (continued)

(V+ = +4.5V to +6V, V- = -4.5V to -6V, V_{IH} = +2.4V, V_{IL} = +0.8V, GND = 0, T_A = T_{MIN} to T_{MAX}, unless otherwise noted. Typical values are at T_A = +25°C.) (Notes 2, 3)

PARAMETER	SYMBOL	CONDITIONS	T _A	MIN	TYP	MAX	UNITS
SWITCH DYNAMIC CHARACTERISTICS							
Turn-On Time	t _{ON}	V _{NO} , V _{NC} = +3V, -3V, R _L = 1kΩ, C _L = 35pF	+25°C	40	60	75	ns
			E				
Turn-Off Time	t _{OFF}	V _{NO} , V _{NC} = +3V, -3V, R _L = 1kΩ, C _L = 35pF	+25°C	28	40	50	ns
			E				
Transition Time	t _{TRANS}	V _{NC} = +3V, V _{NO} = -3V, V _{NC} = -3V, V _{NO} = +3V, R _L = 1kΩ, C _L = 35pF	+25°C	50	70	85	ns
			E				
Break-Before-Make Time (Note 6)	t _{BBM}	V _{NO} , V _{NC} = +3V, -3V, R _L = 300Ω, C _L = 35pF	+25°C	5	15		ns
Charge Injection	Q	V _{GEN} = 0, R _{GEN} = 0, C _L = 100pF	+25°C		3		pC
-3dB Bandwidth	f _{-3dB}	R _L = 50Ω, C _L = 10pF, f _{0dB} = 1MHz	+25°C		450		MHz
Off-Isolation (Note 7)	V _{ISO}	R _L = 50Ω, C _L = 10pF, f _{IN} = 1MHz	+25°C		-77		dB
Crosstalk (Control Input to Signal Output)		R _L = 50Ω, C _L = 10pF, V ₊ = +4.5V, V ₋ = -4.5V, f _{IN} = 1MHz, V _{EN} = V _{IH}	+25°C		68		mV
Crosstalk (Between Switches)	V _{CT}	R _L = 50Ω, C _L = 10pF, f _{IN} = 1MHz	+25°C		-72		dB
Total Harmonic Distortion	THD	R _L = 600kΩ, C _L = 50pF, f _{IN} = 20kHz	+25°C		0.15		%
Control Input Capacitance	C _{IN}				3		pF
NO or NC Off-Capacitance	C _{OFF}	f _{IN} = 1MHz	+25°C		6		pF
COM Off-Capacitance	C _{COM(OFF)}	f _{IN} = 1MHz	+25°C		8		pF
COM On-Capacitance	C _{COM(ON)}	f _{IN} = 1MHz	+25°C		14		pF
LOGIC INPUT							
Input Voltage Low	V _{IL}					0.8	V
Input Voltage High	V _{IH}			2.4			V
Input Leakage Current	I _L	V ₊ = +5.5V, V ₋ = -5.5V, V _{IN} = V _{EN} = 0 or +5.5V	+25°C	-1	0.0001	1	μA
			E	-10		10	
POWER SUPPLY							
Power-Supply Range	V ₊			2		6	V
	V ₋			-2		-6	
Positive Supply Current	I ₊	V ₊ = +5.5V, V ₋ = -5.5V, V _{IN} = V _{EN} = 0 or +5.5V	+25°C	-1	0.0001	1	μA
			E	-10		10	
Negative Supply Current	I ₋	V ₊ = +5.5V, V ₋ = -5.5V, V _{IN} = V _{EN} = 0 or +5.5V	+25°C	-1	0.0001	1	μA
			E	-10		10	

Low-Voltage, Dual-Supply, SPDT Analog Switch with Enable

ELECTRICAL CHARACTERISTICS—Single +5V Supply

($V_+ = +4.5V$ to $+6V$, $V_- = 0$, $V_{IH} = +2.4V$, $V_{IL} = +0.8V$, $GND = 0$, $T_A = T_{MIN}$ to T_{MAX} , unless otherwise noted. Typical values are at $T_A = +25^\circ C$.) (Notes 2, 3)

PARAMETER	SYMBOL	CONDITIONS	T_A	MIN	TYP	MAX	UNITS
ANALOG SWITCH							
Analog Signal Range	V_{COM} , V_{NO} , V_{NC}			0		V_+	V
On-Resistance	R_{ON}	$V_+ = +4.5V$, $V_- = 0$, $I_{COM} = 1mA$; V_{NO} , $V_{NC} = +3.5V$	+25°C		72	100	Ω
			E			125	
On-Resistance Match Between Channels (Note 4)	ΔR_{ON}	$V_+ = +4.5V$, $V_- = 0$, $I_{COM} = 1mA$; V_{NO} , $V_{NC} = +3.5V$	+25°C		0.75	5	Ω
			E			7	
SWITCH DYNAMIC CHARACTERISTICS							
Turn-On Time	t_{ON}	V_{NO} , $V_{NC} = +3V$, $R_L = 1k\Omega$, $C_L = 35pF$	+25°C		62	90	ns
			E			125	
Turn-Off Time	t_{OFF}	V_{NO} , $V_{NC} = +3V$, $R_L = 1k\Omega$, $C_L = 35pF$	+25°C		22	60	ns
			E			75	
Transition Time	t_{TRANS}	$V_{NC} = +3V$, $V_{NO} = 0$, $V_{NC} = 0$, $V_{NO} = +3V$, $R_L = 1k\Omega$, $C_L = 35pF$	+25°C		68	100	ns
			E			130	
Break-Before-Make Time (Note 6)	t_{BBM}	V_{NO} , $V_{NC} = +3V$, $R_L = 300\Omega$, $C_L = 35pF$	E	10	35		ns
LOGIC INPUT							
Input Voltage Low	V_{IL}					0.8	V
Input Voltage High	V_{IH}			2.4			V
Input Leakage Current	I_L	$V_+ = +5.5V$, $V_- = 0$, $V_{IN} = V_{\overline{EN}} = 0$ or $+5.5V$	+25°C	-1	0.0001	1	μA
			E	-10		10	
POWER SUPPLY							
Power-Supply Range	V_+			1.8		12	V
Positive Supply Current	I_+	$V_+ = +5.5V$, $V_- = 0$, $V_{IN} = V_{\overline{EN}} = 0$ or $+5.5V$	+25°C	-1	0.0001	1	μA
			E	-10		10	
Negative Supply Current	I_-	$V_+ = +5.5V$, $V_- = 0$, $V_{IN} = V_{\overline{EN}} = 0$ or $+5.5V$	+25°C	-1	0.0001	1	μA
			E	-10		10	

Low-Voltage, Dual-Supply, SPDT Analog Switch with Enable

MAX4564

ELECTRICAL CHARACTERISTICS—Single +3V Supply

($V_+ = +2.7V$ to $+3.3V$, $V_- = 0$, $V_{IH} = +2.4V$, $V_{IL} = +0.8V$, $GND = 0$, $T_A = T_{MIN}$ to T_{MAX} , unless otherwise noted. Typical values are at $T_A = +25^\circ C$.) (Notes 2, 3)

PARAMETER	SYMBOL	CONDITIONS	T_A	MIN	TYP	MAX	UNITS
ANALOG SWITCH							
Analog Signal Range	V_{COM} , V_{NO} , V_{NC}			0		V_+	V
On-Resistance	R_{ON}	$V_+ = +2.7V$, $V_- = 0$, $I_{COM} = 1mA$; V_{NO} , $V_{NC} = +1.5V$	$+25^\circ C$		160	275	Ω
			E			300	
On-Resistance Match Between Channels (Note 4)	ΔR_{ON}	$V_+ = +2.7V$, $V_- = 0$, $I_{COM} = 1mA$; V_{NO} , $V_{NC} = +1.5V$	$+25^\circ C$		1.5	10	Ω
			E			12	
SWITCH DYNAMIC CHARACTERISTICS							
Turn-On Time	t_{ON}	V_{NO} , $V_{NC} = +1.5V$, $R_L = 2k\Omega$, $C_L = 35pF$	$+25^\circ C$		120	250	ns
			E			275	
Turn-Off Time	t_{OFF}	V_{NO} , $V_{NC} = +1.5V$, $R_L = 2k\Omega$, $C_L = 35pF$	$+25^\circ C$		40	110	ns
			E			125	
Break-Before-Make Time (Note 6)	t_{BBM}	V_{NO} , $V_{NC} = +1.5V$, $R_L = 2k\Omega$, $C_L = 35pF$	E		10		ns
LOGIC INPUT							
Input Voltage Low	V_{IL}					0.8	V
Input Voltage High	V_{IH}			2.4			V
Input Leakage Current	I_L	$V_+ = +3.3V$, $V_- = 0$, $V_{IN} = V_{\overline{EN}} = 0$ or $+3.3V$	$+25^\circ C$	-1	0.0001	1	μA
			E	-10		10	

Note 2: The algebraic convention is used in this data sheet; the most negative value is shown in the minimum column.

Note 3: SOT-packaged products are 100% tested at $+25^\circ C$ and guaranteed by design at the full-rated temperature.

Note 4: $\Delta R_{ON} = R_{ON(MAX)} - R_{ON(MIN)}$.

Note 5: Flatness is defined as the difference between the maximum and minimum value of on-resistance as measured over the specified analog signal ranges.

Note 6: Guaranteed by design.

Note 7: Off-Isolation = $20\log_{10}(V_{COM} / V_{NO})$, V_{NO} = input to off switch.

Low-Voltage, Dual-Supply, SPDT Analog Switch with Enable

Typical Operating Characteristics

($T_A = +25^\circ\text{C}$, unless otherwise noted.)

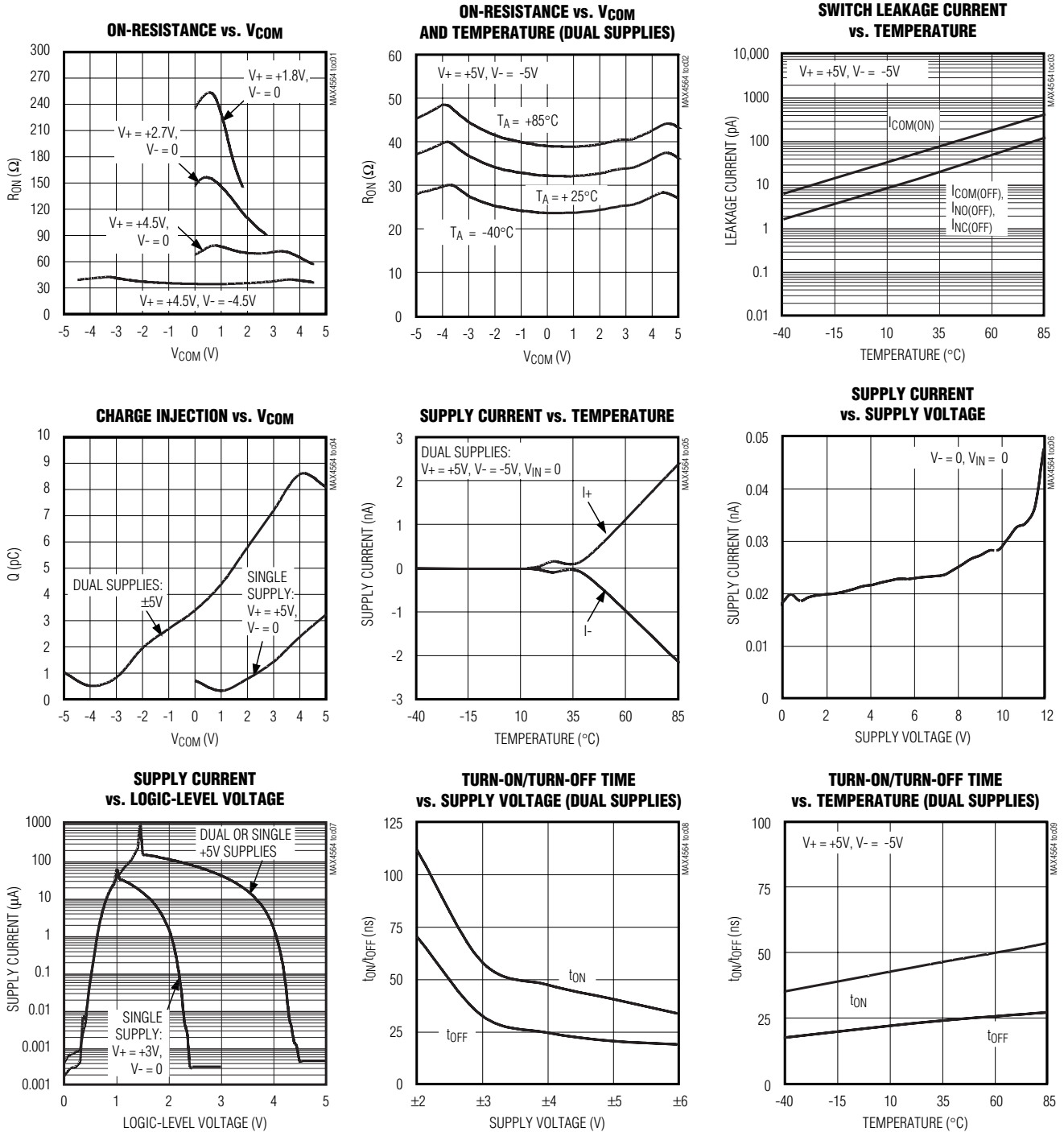

Low-Voltage, Dual-Supply, SPDT Analog Switch with Enable

Typical Operating Characteristics (continued)

($T_A = +25^\circ\text{C}$, unless otherwise noted.)

MAX4564

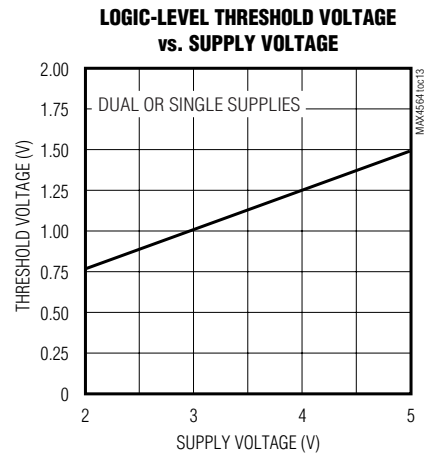
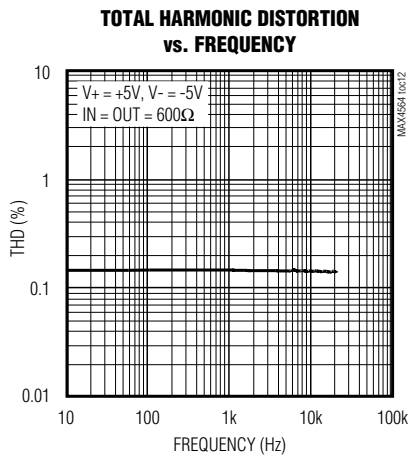
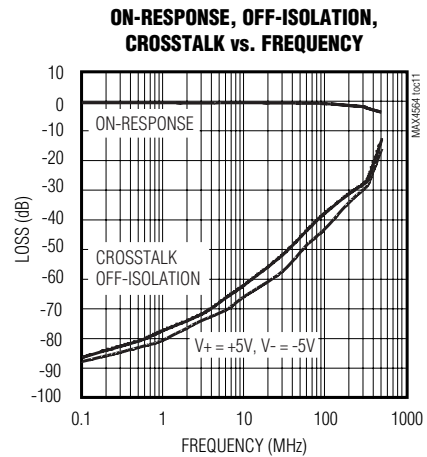
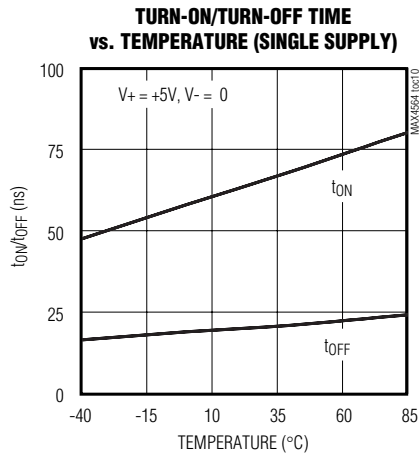

Low-Voltage, Dual-Supply, SPDT Analog Switch with Enable

Pin Description

μ MAX	SOT23	NAME	FUNCTION
1	8	COM	Analog Switch Common
2	7	$\overline{\text{EN}}$	Device Enable. Drive $\overline{\text{EN}}$ low for normal SPDT switch operation. If $\overline{\text{EN}}$ is high, both NO and NC are disconnected.
3	6	V-	Negative Supply Voltage
4	5	GND	Ground
5	3	IN	Digital Control Input
6	4	NO	Analog Switch Normally Open
7	1	NC	Analog Switch Normally Closed
8	2	V+	Positive Supply Voltage

Detailed Description

The MAX4564 is a dual-supply SPDT CMOS analog switch. The MAX4564 has break-before-make switching. The CMOS switch construction provides Rail-to-Rail[®] signal handling while consuming virtually no power. Each of the two switches is independently controlled by a TTL/CMOS-level-compatible digital input.

Applications Information

Overvoltage Protection

Do not exceed the absolute maximum ratings because stresses beyond the listed ratings may cause permanent damage to the device. Proper power-supply sequencing is recommended for all CMOS devices. Always sequence V+ on first, then V-, followed by the logic inputs NO, NC, or COM. If power-supply sequencing is not possible, add two small-signal diodes (D1, D2) in series with supply pins. Adding diodes reduces the analog signal range to one diode drop below V+ and one diode drop above V-, but does not affect the device's low switch resistance and low leakage characteristics.

Test Circuits/ Timing Diagrams

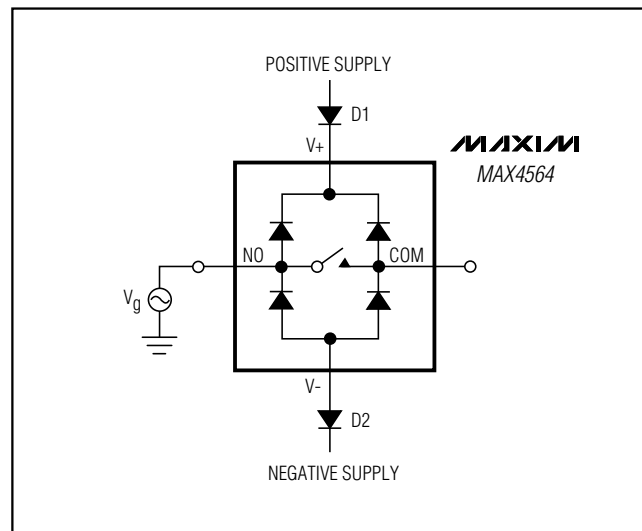

Figure 1. Overvoltage Protection Using Two External Blocking Diodes

Rail-to-Rail is a registered trademark of Nippon Motorola, Ltd.

Low-Voltage, Dual-Supply, SPDT Analog Switch with Enable

Test Circuits/Timing Diagrams (continued)

MAX4564

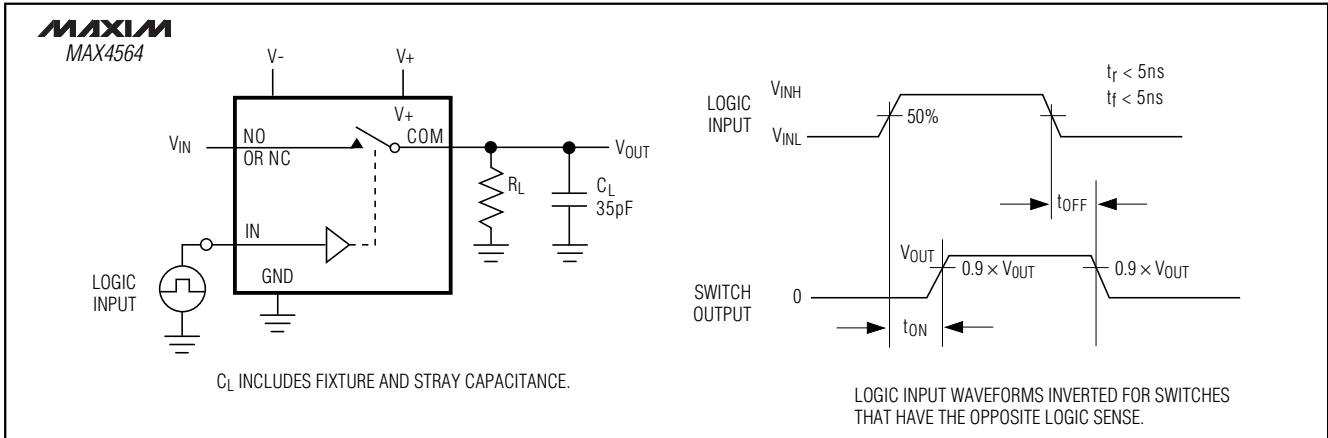

Figure 2. Switching Time

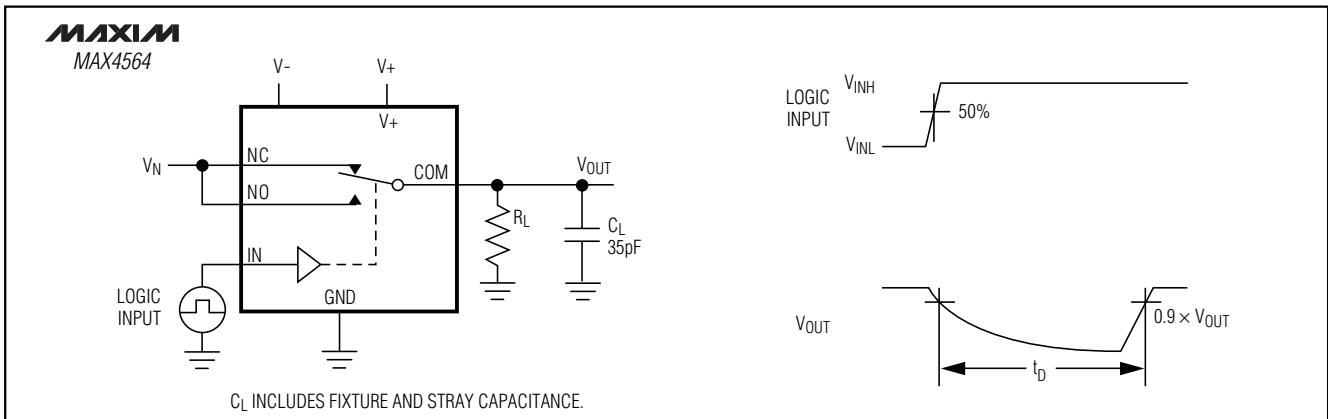

Figure 3. Break-Before-Make Interval

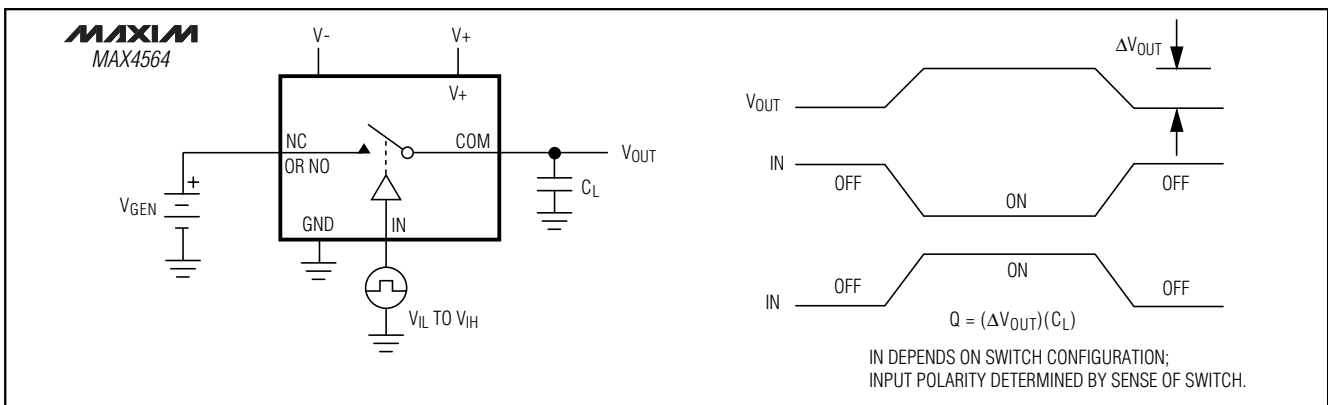

Figure 4. Charge Injection

Low-Voltage, Dual-Supply, SPDT Analog Switch with Enable

Test Circuits/Timing Diagrams (continued)

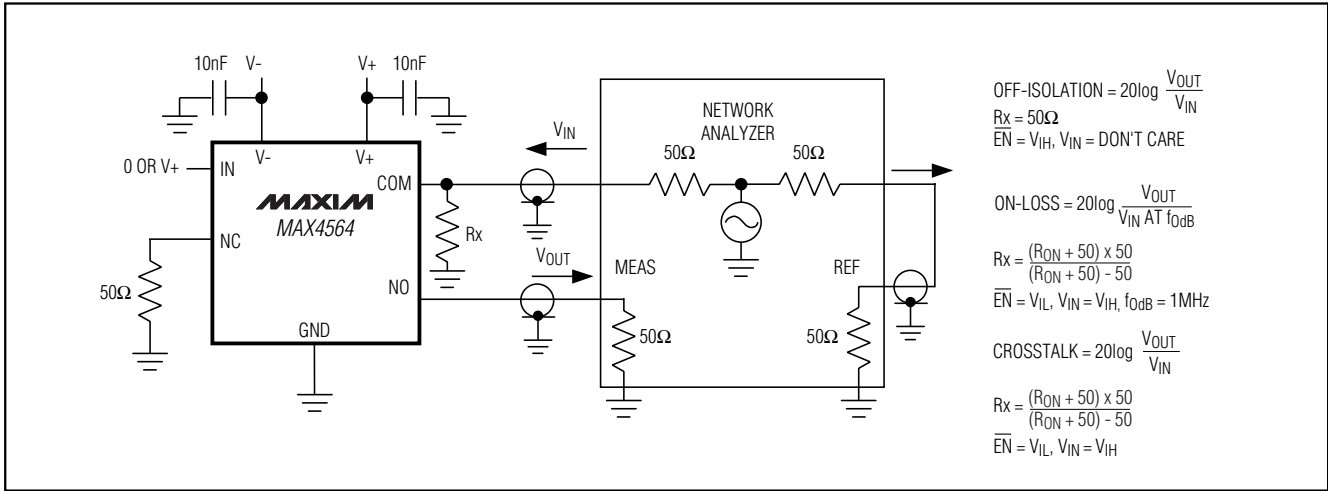

Figure 5. On-Loss, Off-Isolation, and Crosstalk

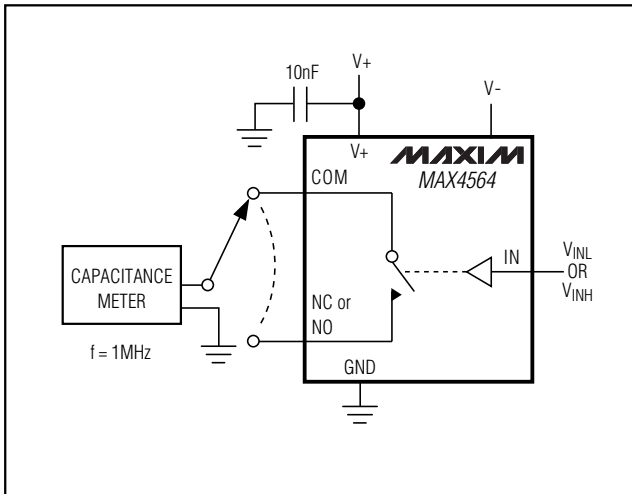

Figure 6. Channel Off/On-Capacitance

Chip Information

TRANSISTOR COUNT: 116

PROCESS : CMOS

Low-Voltage, Dual-Supply, SPDT Analog Switch with Enable

Package Information

(The package drawing(s) in this data sheet may not reflect the most current specifications. For the latest package outline information, go to www.maxim-ic.com/packages.)

MAX4564

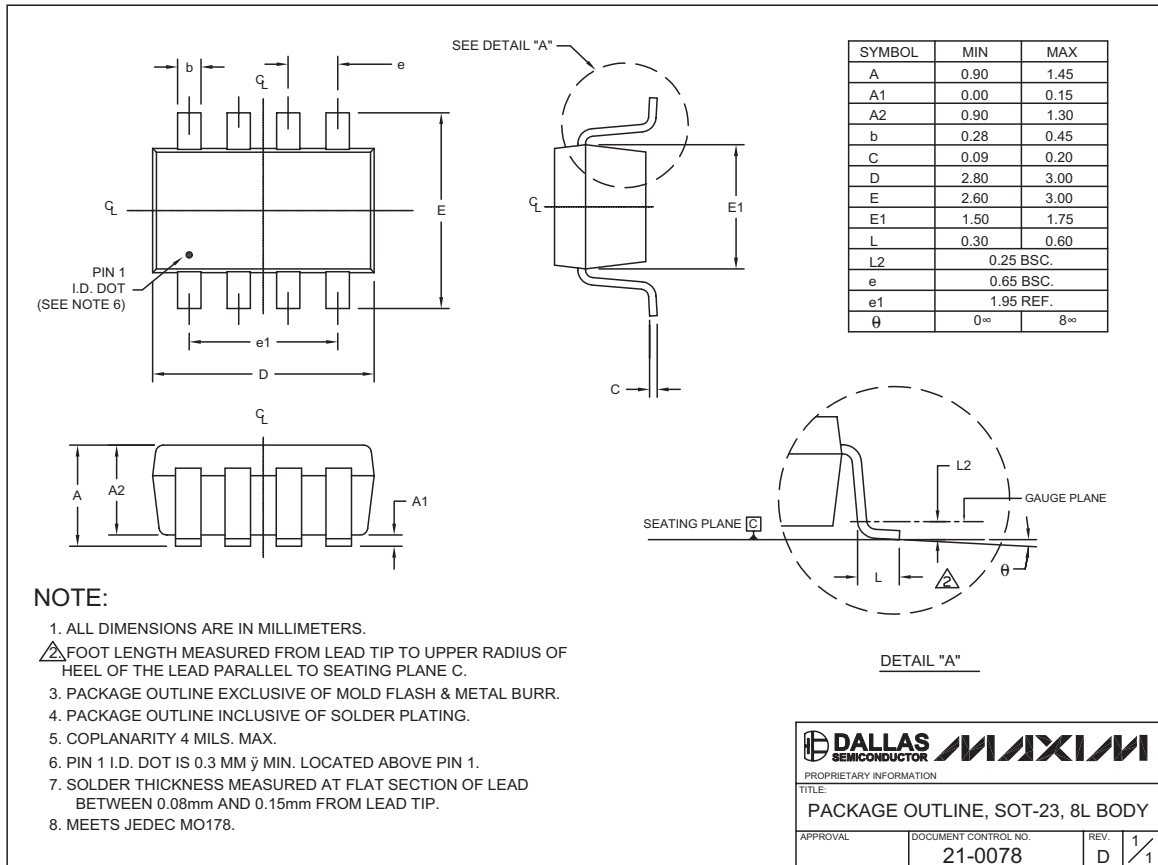

SOT23, 8L-EFS

Low-Voltage, Dual-Supply, SPDT Analog Switch with Enable

Package Information (continued)

(The package drawing(s) in this data sheet may not reflect the most current specifications. For the latest package outline information, go to www.maxim-ic.com/packages.)

8LUMAXD.EPS

DIM	INCHES		MILLIMETERS	
	MIN	MAX	MIN	MAX
A	-	0.043	-	1.10
A1	0.002	0.006	0.05	0.15
A2	0.030	0.037	0.75	0.95
b	0.010	0.014	0.25	0.36
c	0.005	0.007	0.13	0.18
D	0.116	0.120	2.95	3.05
e	0.0256 BSC		0.65 BSC	
E	0.116	0.120	2.95	3.05
H	0.188	0.198	4.78	5.03
L	0.016	0.026	0.41	0.66
α	0°	6°	0°	6°
S	0.0207 BSC		0.5250 BSC	

NOTES:
 1. D&E DO NOT INCLUDE MOLD FLASH.
 2. MOLD FLASH OR PROTRUSIONS NOT TO EXCEED 0.15MM (.006").
 3. CONTROLLING DIMENSION: MILLIMETERS.
 4. MEETS JEDEC MO-187C-AA.

DALLAS SEMICONDUCTOR **MAXIM**

PROPRIETARY INFORMATION

TITLE:
PACKAGE OUTLINE, 8L uMAX/uSOP

APPROVAL	DOCUMENT CONTROL NO. 21-0036	REV. J	1/1
----------	---------------------------------	-----------	-----

Maxim cannot assume responsibility for use of any circuitry other than circuitry entirely embodied in a Maxim product. No circuit patent licenses are implied. Maxim reserves the right to change the circuitry and specifications without notice at any time.

12 **Maxim Integrated Products, 120 San Gabriel Drive, Sunnyvale, CA 94086 408-737-7600**