

## LNB supply and control voltage regulator (parallel interface)

### Feature summary

- Complete interface for two LNBS remote supply and control
- LNB selection and stand-by function
- Built-in tone oscillator factory trimmed at 22KHz
- Fast oscillator start-up facilitates DiSEqC™ encoding
- Two supply inputs for lowest dissipation
- Bypass function for slave operation
- LNB short circuit protection and diagnostic
- Auxiliary modulation input extends flexibility
- Cable length compensation
- Internal over temperature protection
- Backward current protection

### Description

Intended for analog and digital satellite receivers, the LNBK is a monolithic linear voltage regulator, assembled in PowerSO-20 and SO-20, specifically designed to provide the powering voltages and the interfacing signals to the LNB downconverter situated in the antenna

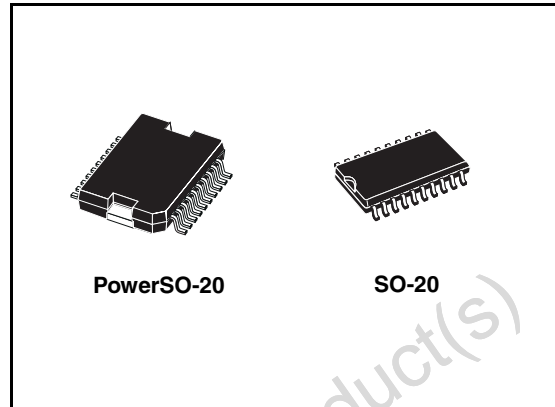

via the coaxial cable. It has the same functionality of the LNBP1X and LNBK20 series, at a reduced output current capability. Since most satellite receivers have two antenna ports, the output voltage of the regulator is available at one of two logic-selectable output pins (LNBA, LNBB). When the IC is powered and put in Stand-by (EN pin LOW), both regulator outputs are disabled to allow the antenna downconverters to be supplied/controlled by others satellite receivers sharing the same coaxial lines. In this occurrence the device will limit at 3 mA (max) the backward current that could flow from LNBA and LNBB output pins to GND. (See continuous description).

### Order code

Part number	Packages		Packaging
	PowerSO-20	SO-20	
LNBK20	LNBK20PD-TR	LNBK20D2-TR	Tape & Reel

---

## Contents

1	Description (continued) .....	3
2	Pin configuration .....	4
3	Maximum ratings .....	7
4	Block diagram .....	8
5	Electrical characteristics .....	9
6	Typical characteristics .....	11
7	Typical application schematics .....	15
8	Package mechanical data .....	19
9	Revision history .....	24

## 1 Description (continued)

For slave operation in single dish, dual receiver systems, the bypass function is implemented by an electronic switch between the Master Input pin (MI) and the LNBA pin, thus leaving all LNB powering and control functions to the Master Receiver. This electronic switch is closed when the device is powered and EN pin is LOW.

The regulator outputs can be logic controlled to be 13 or 18 V (typ.) by mean of the VSEL pin for remote controlling of LNBs. Additionally, it is possible to increment by 1V (typ.) the selected voltage value to compensate the excess voltage drop along the coaxial cable (LLC pin HIGH).

In order to reduce the power dissipation of the device when the lowest output voltage is selected, the regulator has two Supply Input pins  $V_{CC1}$  and  $V_{CC2}$ . They must be powered respectively at 16V (min) and 23V (min), and an internal switch automatically will select the suitable supply pin according to the selected output voltage. If adequate heatsink is provided and higher power losses are acceptable, both supply pins can be powered by the same 23V source without affecting any other circuit performance.

The ENT (Tone Enable) pin activates the internal oscillator so that the DC output is modulated by a  $\pm 0.3$  V, 22KHz (typ.) square wave. This internal oscillator is factory trimmed within a tolerance of  $\pm 2$ KHz, thus no further adjustments neither external components are required.

A burst coding of the 22KHz tone can be accomplished thanks to the fast response of the ENT input and the prompt oscillator start-up. This helps designers who want to implement the DiSEqC<sup>TM</sup> protocols <sup>(a)</sup>.

In order to improve design flexibility and to allow implementation of newcoming LNB remote control standards, an analogic modulation input pin is available (EXTM). An appropriate DC blocking capacitor must be used to couple the modulating signal source to the EXTM pin. When external modulation is not used, the relevant pin can be left open.

Two pins are dedicated to the overcurrent protection/monitoring: CEXT and OLF. The overcurrent protection circuit works dynamically: as soon as an overload is detected in either LNB output, the output is shut-down for a time  $T_{off}$  determined by the capacitor connected between CEXT and GND. Simultaneously the OLF pin, that is an open collector diagnostic output flag, from HIGH IMPEDANCE state goes LOW.

After the time has elapsed, the output is resumed for a time  $t_{on}=1/15t_{off}$  (typ.) and OLF goes in HIGH IMPEDANCE. If the overload is still present, the protection circuit will cycle again through  $t_{off}$  and  $t_{on}$  until the overload is removed. Typical  $t_{on}+t_{off}$  value is 1200ms when a 4.7 $\mu$ F external capacitor is used.

This dynamic operation can greatly reduce the power dissipation in short circuit condition, still ensuring excellent power-on start up even with highly capacitive loads on LNB outputs.

The device is packaged in PowerSO-20 for surface mounting. When a limited functionality in a smaller package matches design needs, a range of cost-effective PowerSO-10 solutions is also offered. All versions have built-in thermal protection against overheating damage.

---

a. External components are needed to comply to level 2.x and above (bidirectional) DiSEqC<sup>TM</sup> bus hardware requirements. DiSEqC<sup>TM</sup> is a trademark of EUTELSAT.

## 2 Pin configuration

Figure 1. Pin connections (top view)

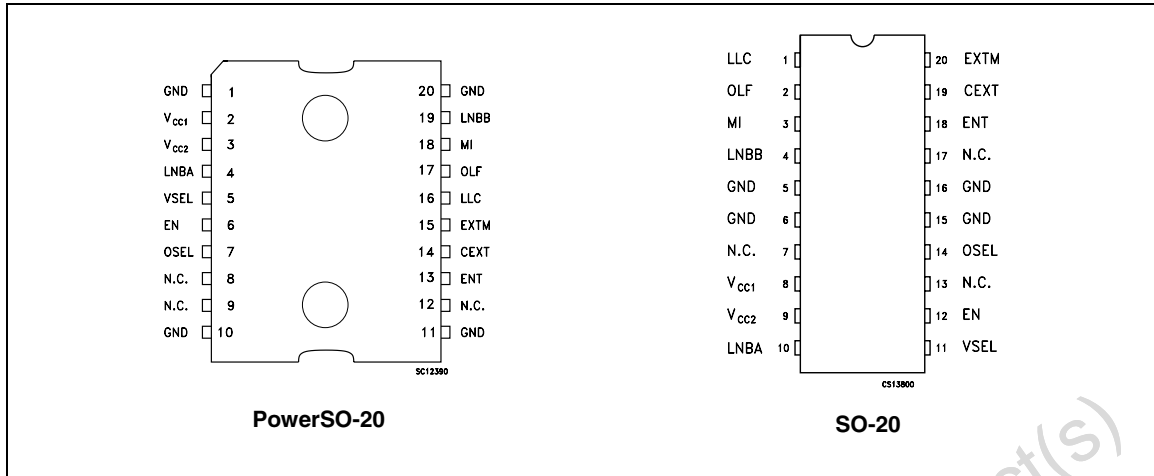

Table 1. Pin description for PowerSO-20

SYMBOL	NAME	FUNCTION	PIN NUMBER vs SALES TYPE (LNBP)								
			20CR	20PD	10SP	11SP	12SP	13SP	14SP	15SP	16SP
V <sub>CC1</sub>	Supply input 1	15V to 27V supply. It is automatically selected when V <sub>OUT</sub> = 13 or 14V	1	2	1	1	1		1	1	1
V <sub>CC2</sub>	Supply input 2	22V to 27V supply. It is automatically selected when V <sub>OUT</sub> = 18 or 19V	2	3	2	2	2	2	2	2	2
LNBA	Output port	See truth table voltage and port selection. In stand-by mode this port is powered by the MI pin via the internal bypass switch	3	4	3	3	3	3	3	3	3
V <sub>SEL</sub>	Output voltage selection: 13 or 18V (typ)	Logic control input: see truth table	4	5	4	4	4	4	4	4	4
EN	Port enable	Logic control input: see truth table	5	6	5	5	5	5	5	5	5
OSEL	Port selection	Logic control input: see truth table	7	7	9	NA	NA	NA	NA	NA	NA
GND	Ground	Circuit ground. It is internally connected to the die frame	8	1 10 11 20	6	6	6	6	6	6	6

Table 1. Pin description for PowerSO-20

SYMBOL	NAME	FUNCTION	PIN NUMBER vs SALES TYPE (LNBP)								
			20CR	20PD	10SP	11SP	12SP	13SP	14SP	15SP	16SP
ENT	22KHz tone enable	Logic control input: see truth table	9	13	7	7	7	7	7	7	7
CEXT	External capacitor	Timing capacitor used by the dynamic overload protection. Typical application is 4.7 $\mu$ F for a 1200ms cycle	10	14	8	8	8	8	8	8	8
EXTM	External modulator	External modulation input. Needs DC decoupling to the AC source. if not used, can be left open.	11	15	NA	NA	NA	9	NA	9	9
LLC	Line length compens. (1V typ)	Logic control input: see truth table	12	16	NA	NA	9	NA	9	NA	10
OLF	Over load flag	Logic output (open collector). Normally in HIGH IMPEDANCE, goes LOW when current or thermal overload occurs	13	17	NA	9	NA	NA	10	10	NA
MI	Master input	In stand-by mode, the voltage on MI is routed to LNBA pin. Can be left open if bypass function is not needed	14	18	NA	10	10	10	NA	NA	NA
LNBB	Output port	See truth tables for voltage and port selection	15	19	10	NA	NA	NA	NA	NA	NA

**Table 2. Pin description for SO-20**

PIN N°	SYMBOL	NAME	FUNCTION
1	LLC	Line Length Compens. (1V typ)	Logic control input: see truth table
2	OLF	Over Load Flag	Logic output (open collector). Normally in HIGH IMPEDANCE, goes LOW when current or thermal overload occurs
3	MI	Master Input	In stand-by mode, the voltage on MI is routed to LNBA pin. Can be left open if bypass function is not needed
4	LNBB	Output Port	See truth tables for voltage and port selection
5, 6, 15, 16	GND	Ground	Circuit Ground. It is internally connected to the die frame
7, 13	N.C.	Not Connected	
8	V <sub>CC1</sub>	Supply Input 1	15V to 27V supply. It is automatically selected when V <sub>OUT</sub> = 13 or 14V
9	V <sub>CC2</sub>	Supply Input 2	22V to 27V supply. It is automatically selected when V <sub>OUT</sub> = 18 or 19V
10	LNBA	Output Port	See truth table voltage and port selection. In stand-by mode this port is powered by the MI pin via the internal Bypass Switch
11	V <sub>SEL</sub>	Output Voltage Selection: 13 or 18V (typ)	Logic control input: see truth table
12	EN	Port Enable	Logic control input: see truth table
14	OSEL	Port Selection	Logic control input: see truth table
18	ENT	22KHz Tone Enable	Logic control input: see truth table
19	CEXT	External Capacitor	Timing Capacitor used by the Dynamic Overload protection. Typical application is 4.7μF for a 1200ms cycle
20	EXTM	External Modulator	External Modulation Input. Needs DC decoupling to the AC source. if not used, can be left open.

### 3 Maximum ratings

**Table 3. Absolute maximum ratings**

Symbol	Parameter	Value	Unit
$V_I$	DC Input voltage ( $V_{CC1}$ , $V_{CC2}$ , MI)	28	V
$V_O$	Output voltage	-0.3 to 28	V
$I_O$	Output current (LNBA, LNBB)	Internally Limited	mA
$V_I$	Logic input voltage (ENT, EN OSEL, VSEL, LLC)	-0.5 to 7	V
$I_{SW}$	Bypass switch current	900	mA
$P_D$	Power dissipation at $T_{case} < 85^\circ\text{C}$	14	W
$T_{stg}$	Storage temperature range	-40 to +150	$^\circ\text{C}$
$T_{op}$	Operating junction temperature range	-40 to +125	$^\circ\text{C}$

*Note:* Absolute Maximum Ratings are those values beyond which damage to the device may occur. Functional operation under these condition is not implied

**Table 4. Thermal data**

Symbol	Parameter	PowerSO-20	SO-20	Unit
$R_{thJC}$	Thermal resistance junction-case	2	15	$^\circ\text{C}/\text{W}$

**Table 5. Logic Controls Truth Table**

CONTROL I/O	PIN NAME	L	H
OUT	OLF	$I_{OUT} > I_{OMAX}$ or $T_j > 150^\circ\text{C}$	$I_{OUT} < I_{OMAX}$
IN	ENT	22KHz tone OFF	22KHz tone ON
IN	EN	See Table Below	See Table Below
IN	OSEL	See Table Below	See Table Below
IN	VSEL	See Table Below	See Table Below
IN	LLC	See Table Below	See Table Below

EN	OSEL	VSEL	LLCO	$V_{LNBA}$	$V_{LNBB}$
L	X	X	X	$V_{MI} - 0.4\text{V}$ (typ.)	Disabled
H	L	L	L	13V (typ.)	Disabled
H	L	H	L	18V (typ.)	Disabled
H	L	L	H	14V (typ.)	Disabled
H	L	H	H	19V (typ.)	Disabled
H	H	L	L	Disabled	13V (typ.)
H	H	H	L	Disabled	18V (typ.)
H	H	L	H	Disabled	14V (typ.)
H	H	H	H	Disabled	19V (typ.)

*Note:* All logic input pins have internal pull-down resistor (typ. = 250K $\Omega$ )

# 4 Block diagram

Figure 2. Block diagram

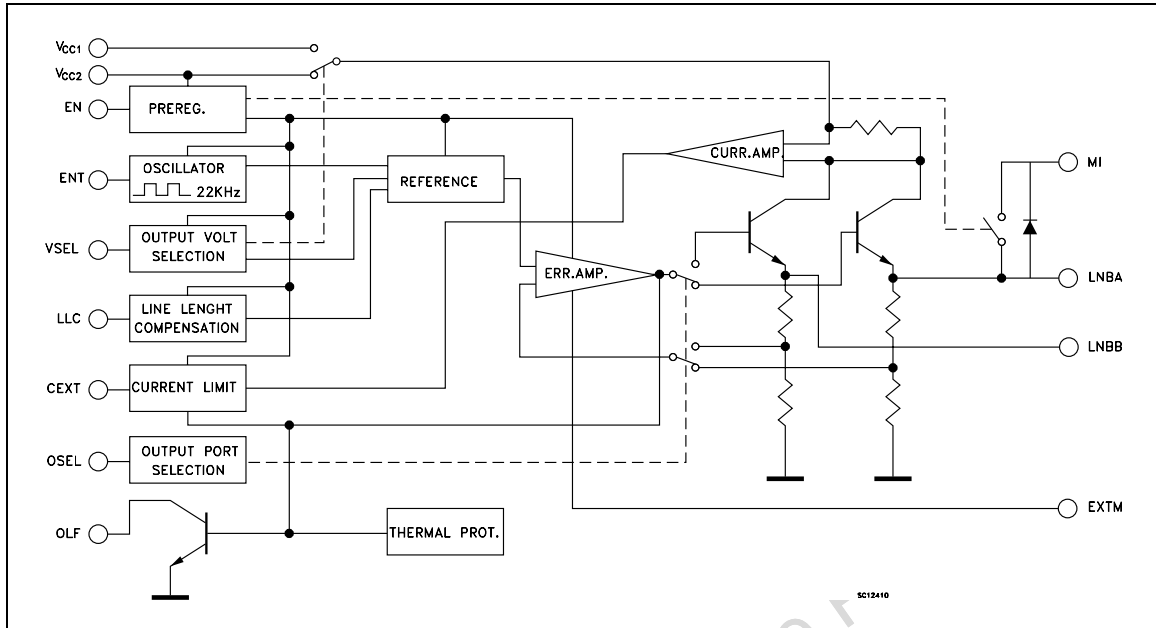



## 5 Electrical characteristics

**Table 6. Electrical characteristics for LNBK Series** ( $T_J = 0$  to  $85^\circ\text{C}$ ,  $C_I = 0.22\mu\text{F}$ ,  $C_O = 0.1\mu\text{F}$ ,  $\text{EN}=\text{H}$ ,  $\text{ENT}=\text{L}$ ,  $\text{LLC}=\text{L}$ ,  $V_{\text{IN}1}=16\text{V}$ ,  $V_{\text{IN}2}=23\text{V}$ ,  $I_{\text{OUT}}=50\text{mA}$ , unless otherwise specified.)

Symbol	Parameter	Test conditions	Min.	Typ.	Max.	Unit
$V_{\text{IN}1}$	$V_{\text{CC}1}$ Supply voltage	$I_O = 400\text{ mA}$ , $\text{ENT}=\text{H}$ , $\text{VSEL}=\text{L}$ , $\text{LLC}=\text{L}$	15		27	V
		$I_O = 400\text{ mA}$ , $\text{ENT}=\text{H}$ , $\text{VSEL}=\text{L}$ , $\text{LLC}=\text{H}$	16		27	V
$V_{\text{IN}2}$	$V_{\text{CC}2}$ Supply voltage	$I_O = 400\text{ mA}$ , $\text{ENT}=\text{H}$ , $\text{VSEL}=\text{L}$ , $\text{LLC}=\text{L}$	22		27	V
		$I_O = 400\text{ mA}$ , $\text{VSEL}=\text{L}$ , $\text{LLC}=\text{H}$	23		27	V
$V_{\text{O}1}$	Output voltage	$I_O = 400\text{ mA}$ , $\text{VSEL}=\text{L}$ , $\text{LLC}=\text{L}$	17.3	18	18.7	V
		$I_O = 400\text{ mA}$ , $\text{ENT}=\text{H}$ , $\text{VSEL}=\text{L}$ , $\text{LLC}=\text{H}$		19		V
$V_{\text{O}2}$	Output voltage	$I_O = 400\text{ mA}$ , $\text{VSEL}=\text{L}$ , $\text{LLC}=\text{L}$	12.5	13	13.5	V
		$I_O = 400\text{ mA}$ , $\text{ENT}=\text{H}$ , $\text{VSEL}=\text{L}$ , $\text{LLC}=\text{H}$		14		V
$\Delta V_O$	Line regulation	$V_{\text{IN}1}=15$ to $18\text{V}$ , $V_{\text{OUT}}=13\text{V}$		5	50	mV
		$V_{\text{IN}2}=22$ to $25\text{V}$ , $V_{\text{OUT}}=18\text{V}$		5	50	mV
$\Delta V_O$	Load regulation	$V_{\text{IN}1}=V_{\text{IN}2}=22\text{V}$ , $V_{\text{OUT}}=13$ or $18\text{V}$ $I_O = 0$ to $3\text{A}$		65	150	mV
SVR	Supply voltage rejection	$V_{\text{IN}1} = V_{\text{IN}2} = 23 \pm 0.5V_{\text{ac}}$ , $f_{\text{ac}} = 120\text{ Hz}$ ,		45		dB
$I_{\text{MAX}}$	Output current limiting		400	500	600	mA
$t_{\text{OFF}}$	Dynamic overload protection OFF time	Output Shorted, $C_{\text{EXT}} = 4.7\mu\text{F}$		1100		ms
$t_{\text{ON}}$	Dynamic overload protection ON time	Output Shorted, $C_{\text{EXT}} = 4.7\mu\text{F}$		$t_{\text{OFF}}/15$		ms
$f_{\text{TONE}}$	Tone frequency	$\text{ENT}=\text{H}$	20	22	24	KHz
$A_{\text{TONE}}$	Tone amplitude	$\text{ENT}=\text{H}$	0.55	0.72	0.9	$V_{\text{PP}}$
$D_{\text{TONE}}$	Tone duty cycle	$\text{ENT}=\text{H}$	40	50	60	%
$t_r, t_f$	Tone rise and fall time	$\text{ENT}=\text{H}$	5	10	15	$\mu\text{s}$
$G_{\text{EXTM}}$	External modulation gain	$\Delta V_{\text{OUT}}/\Delta V_{\text{EXTM}}$ , $f = 10\text{Hz}$ to $40\text{KHz}$		5		
$V_{\text{EXTM}}$	External modulation input voltage	AC Coupling			400	$\text{mV}_{\text{PP}}$
$Z_{\text{EXTM}}$	External modulation impedance	$f = 10\text{Hz}$ to $40\text{KHz}$		400		$\Omega$
$V_{\text{SW}}$	Bypass switch voltage drop (MI to LNBA)	$\text{EN}=\text{L}$ , $I_{\text{SW}}=300\text{mA}$ , $V_{\text{CC}2}-V_{\text{MI}}=4\text{V}$		0.35	0.6	V
$V_{\text{OL}}$	Overload flag pin logic LOW	$I_{\text{OL}}=8\text{mA}$		0.28	0.5	V
$I_{\text{OZ}}$	Overload flag pin OFF state leakage current	$V_{\text{OH}} = 6\text{V}$			10	$\mu\text{A}$
$V_{\text{IL}}$	Control input pin logic LOW				0.8	V

**Table 6. Electrical characteristics for LNBK Series** ( $T_J = 0$  to  $85^\circ\text{C}$ ,  $C_I = 0.22\mu\text{F}$ ,  $C_O = 0.1\mu\text{F}$ ,  $\text{EN}=\text{H}$ ,  $\text{ENT}=\text{L}$ ,  $\text{LLC}=\text{L}$ ,  $V_{\text{IN}1}=16\text{V}$ ,  $V_{\text{IN}2}=23\text{V}$   $I_{\text{OUT}}=50\text{mA}$ , unless otherwise specified.)

Symbol	Parameter	Test conditions	Min.	Typ.	Max.	Unit
$V_{\text{IH}}$	Control input pin logic HIGH		2.5			V
$I_{\text{IH}}$	Control pins input current	$V_{\text{IH}} = 5\text{V}$		20		$\mu\text{A}$
$I_{\text{CC}}$	Supply current	Output Disabled ( $\text{EN}=\text{L}$ )		0.3	1	mA
		$\text{ENT}=\text{H}$ , $I_{\text{OUT}}=500\text{mA}$		3.1	6	mA
$I_{\text{OBK}}$	Output backward current	$\text{EN}=\text{L}$ , $V_{\text{LNBA}} = V_{\text{LNBB}} = 18\text{V}$ $V_{\text{IN}1} = V_{\text{IN}2} = 22\text{V}$ or floating		0.2	3	mA
$T_{\text{SHDN}}$	Temperature shutdown threshold			150		$^\circ\text{C}$

Obsolete Product(s) - Obsolete Product(s)

## 6 Typical characteristics

(unless otherwise specified  $T_J = 25^\circ\text{C}$ )

Figure 3. Output voltage vs output current

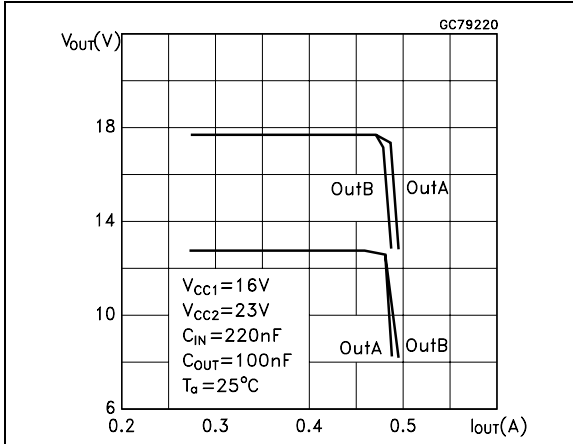

Figure 4. Tone duty cycle vs temperature

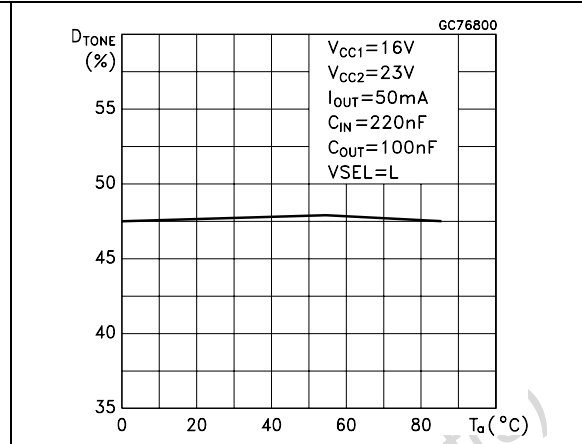

Figure 5. Tone fall time vs temperature

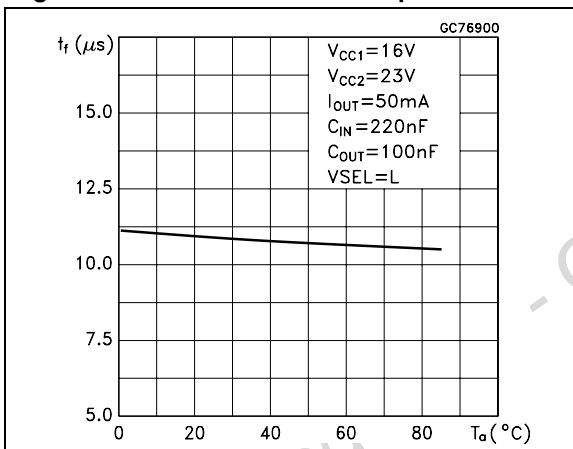

Figure 6. Tone frequency vs temperature

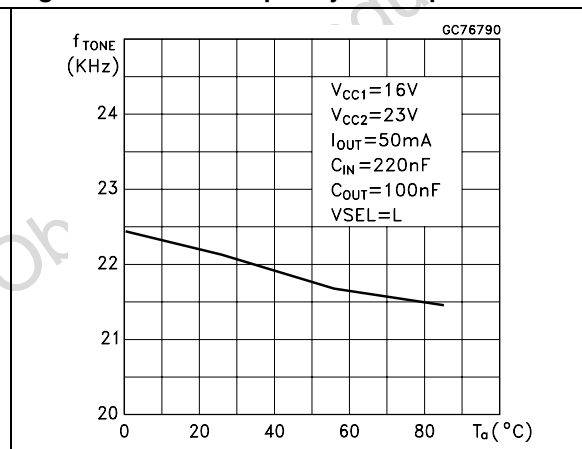

Figure 7. Tone rise time vs temperature

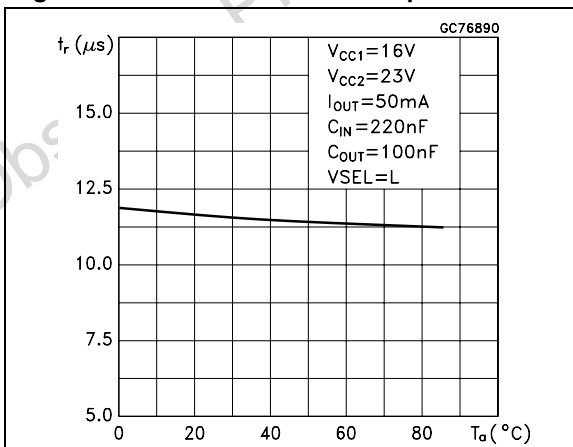

Figure 8. Tone amplitude vs temperature

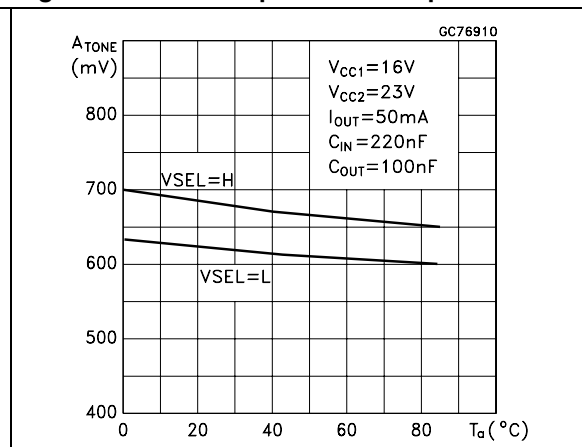

Figure 9. S.V.R. vs Frequency

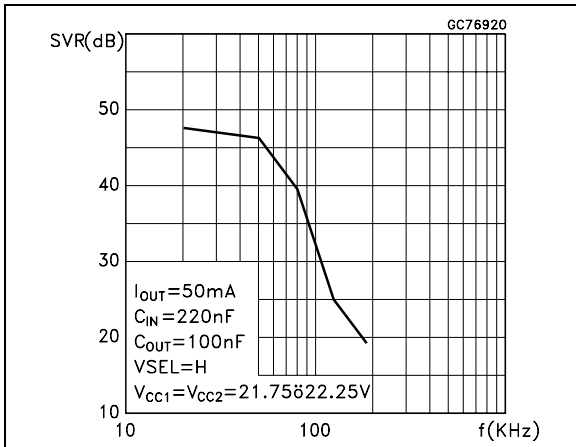

Figure 10. External modulation vs temperature

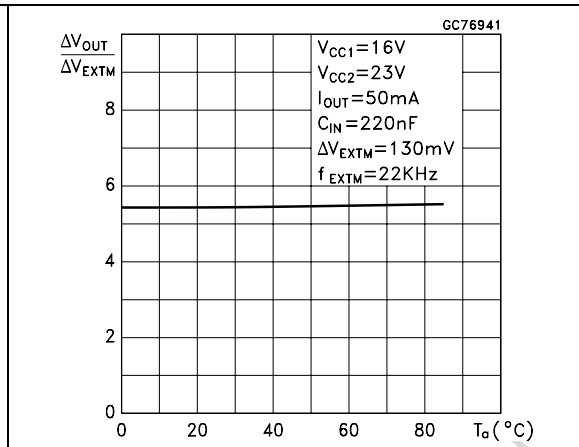

Figure 11. Bypass switch drop vs output current

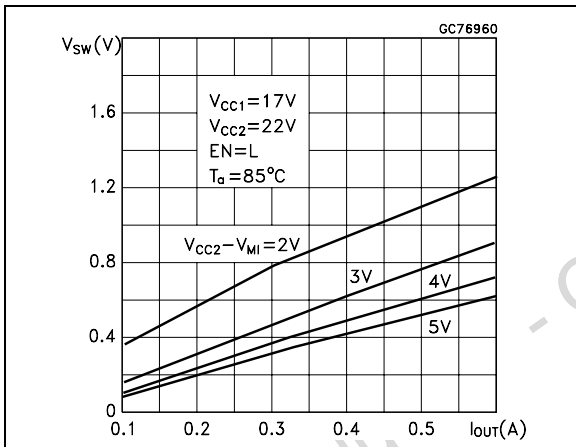

Figure 12. LNBA External modulation gain vs frequency

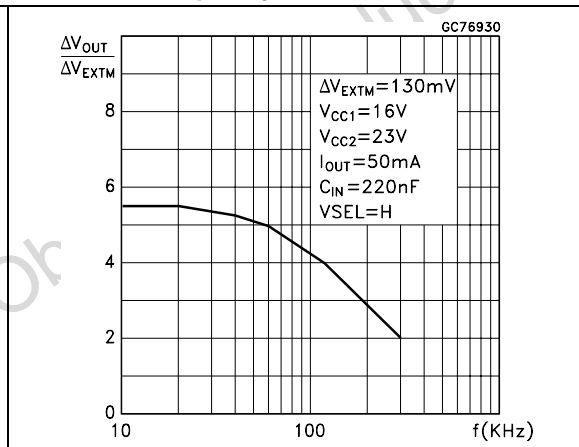

Figure 13. Bypass switch drop vs output current

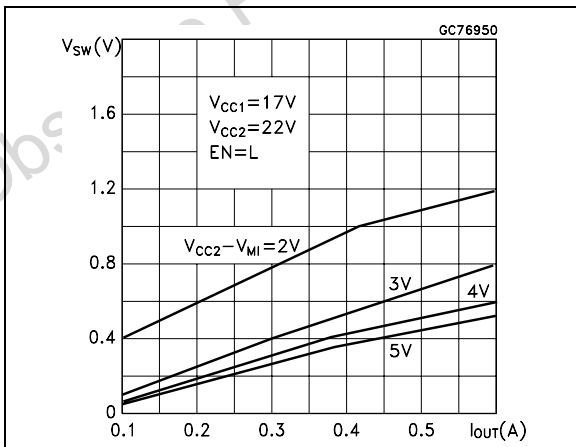

Figure 14. Overload flag pin logic low vs flag current

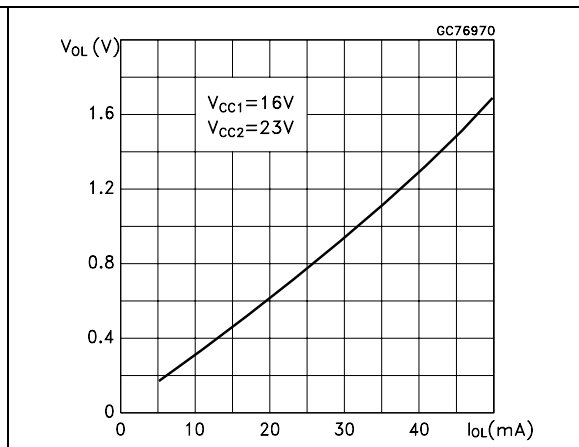

Figure 15. Supply current vs temperature

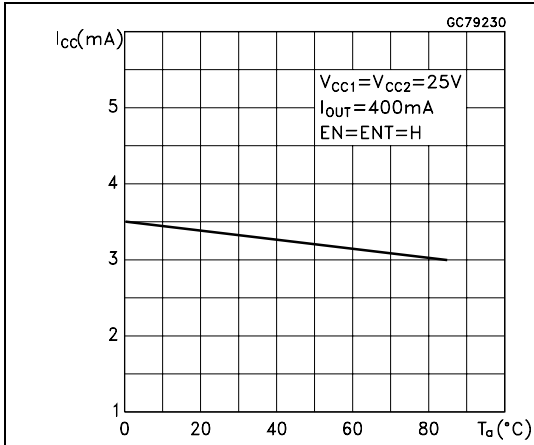

Figure 16. Supply current vs temperature

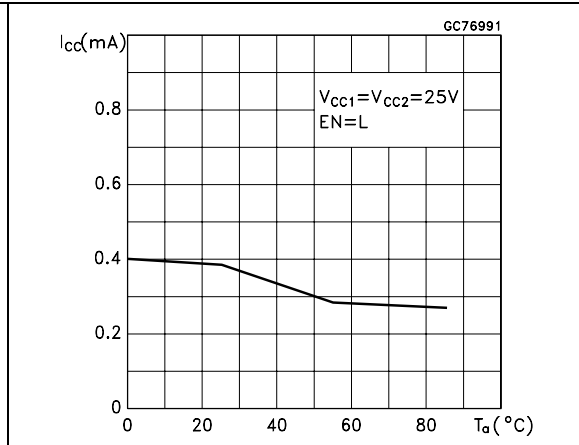

Figure 17. Dynamic overload protection (Isc vs time)

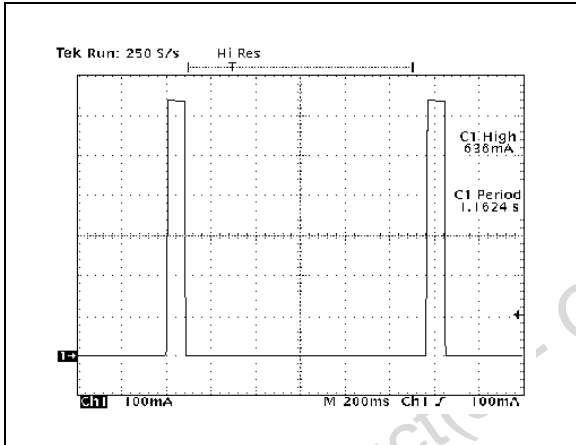

Figure 18. Tone enable

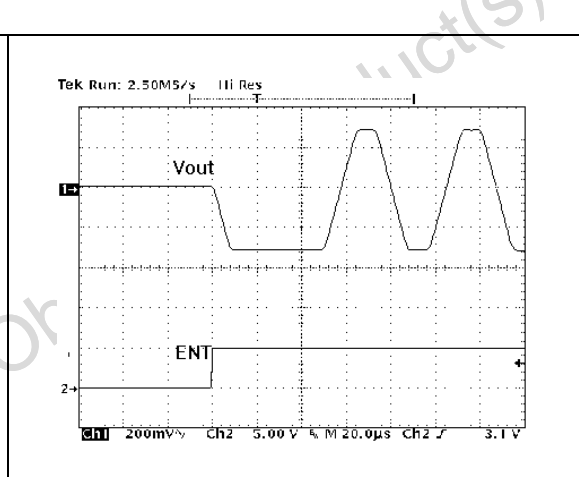

Figure 19. Tone disable

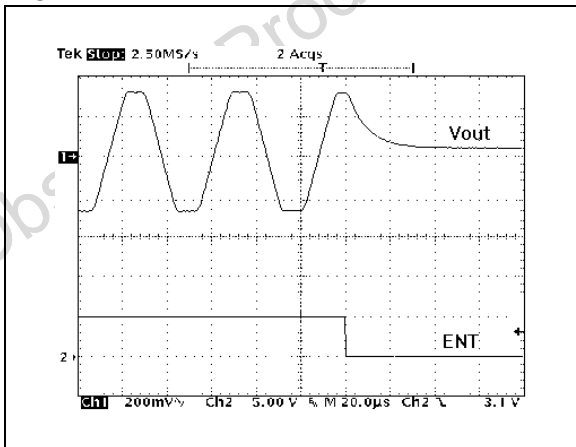

Figure 20. 22KHz Tone

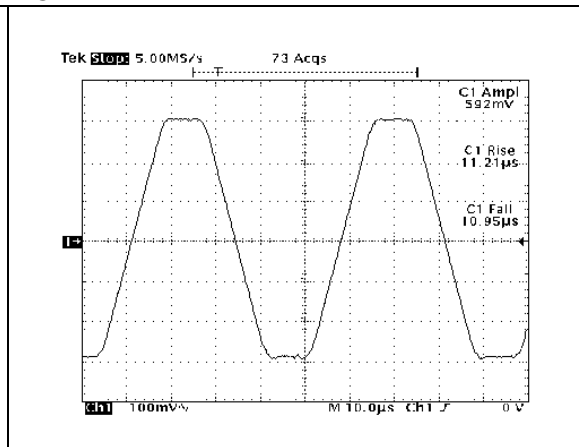

Figure 21. Enable time

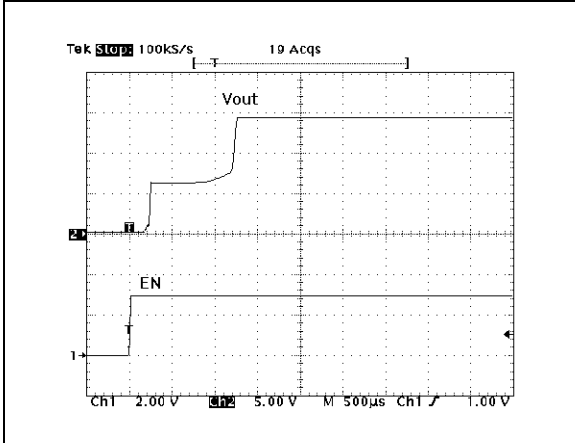

Figure 22. Disable time

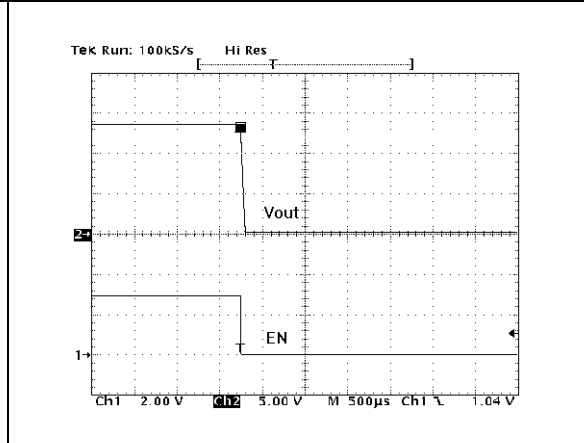

Figure 23. 18V to 13V Change

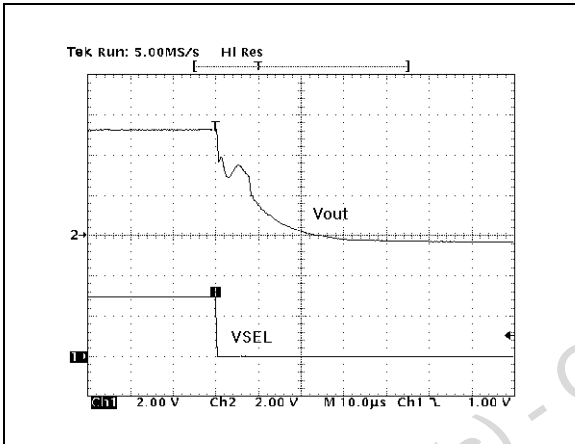
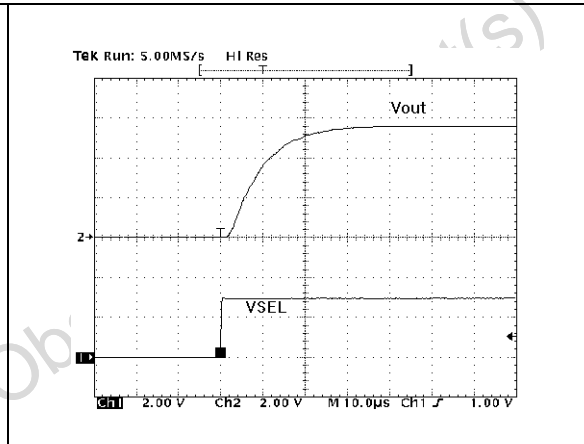

Figure 24. 18V to 13V Change



# 7 Typical application schematics

Figure 25. Two antenna ports receiver

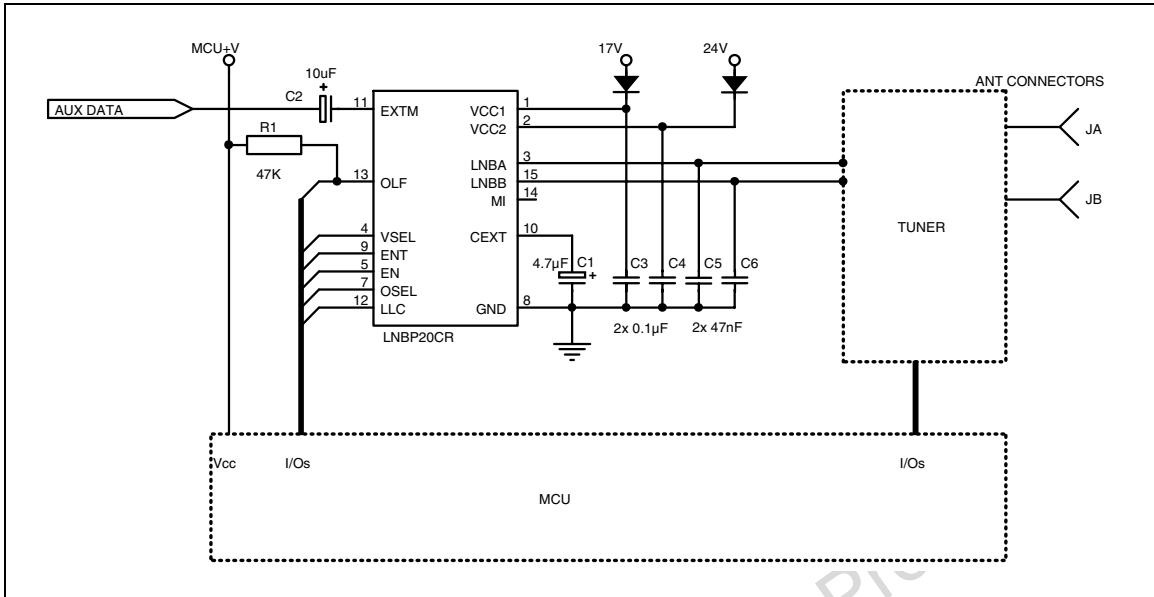

Figure 26. Single antenna receiver with master receiver port

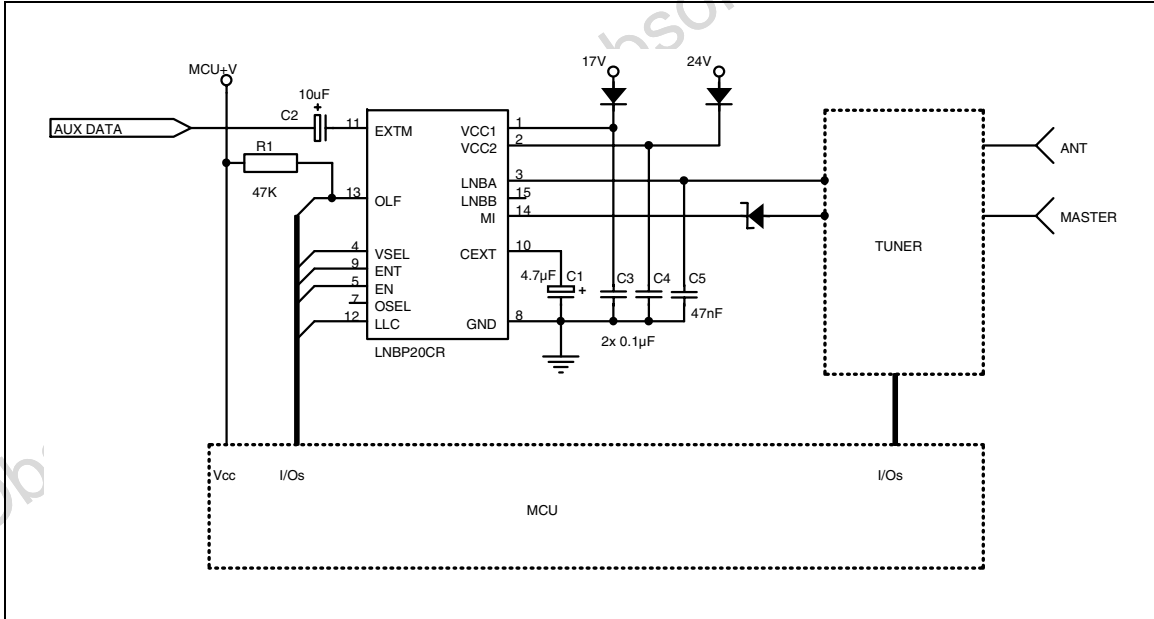

Figure 27. Using serial bus to save MPU I/os

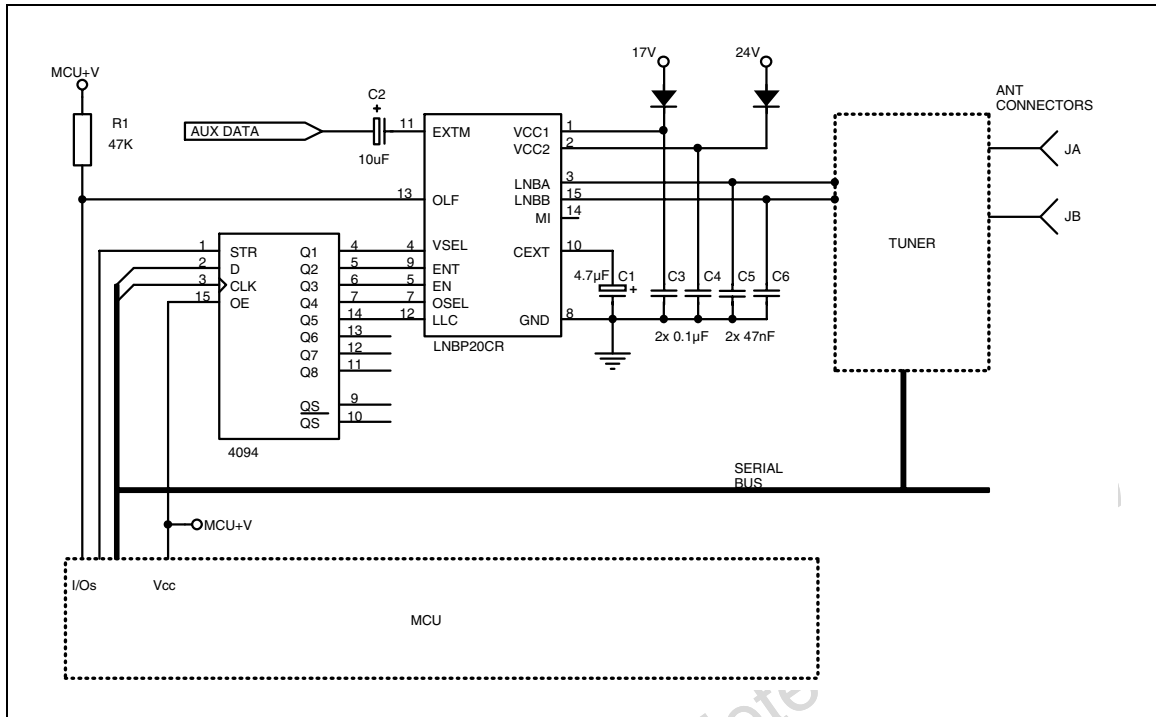

Figure 28. Two antenna ports receiver - low cost solution

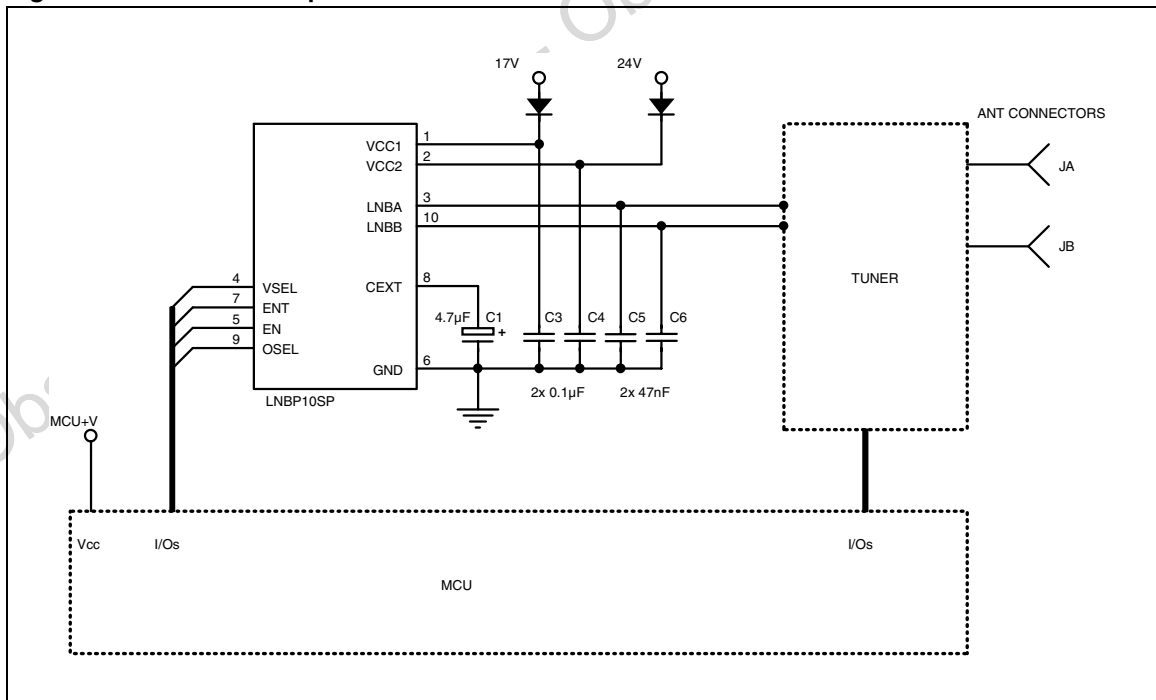



Figure 29. Connecting together V<sub>CC1</sub> and V<sub>CC2</sub>

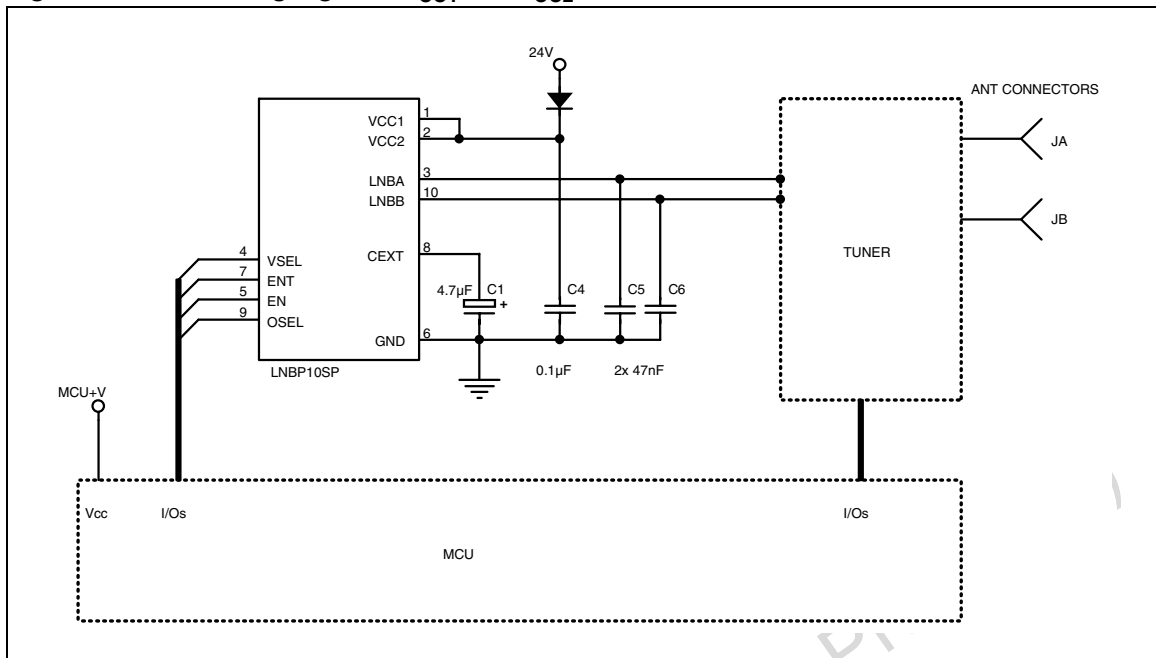

Figure 30. Single antenna receiver with master receiver port - low cost solution

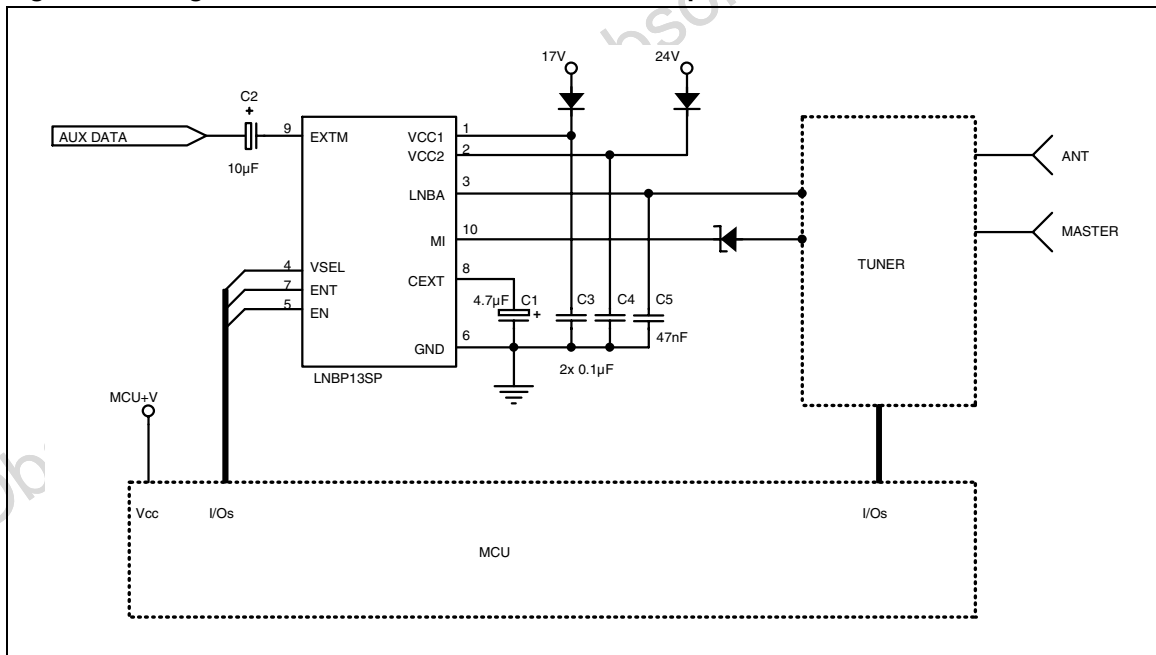
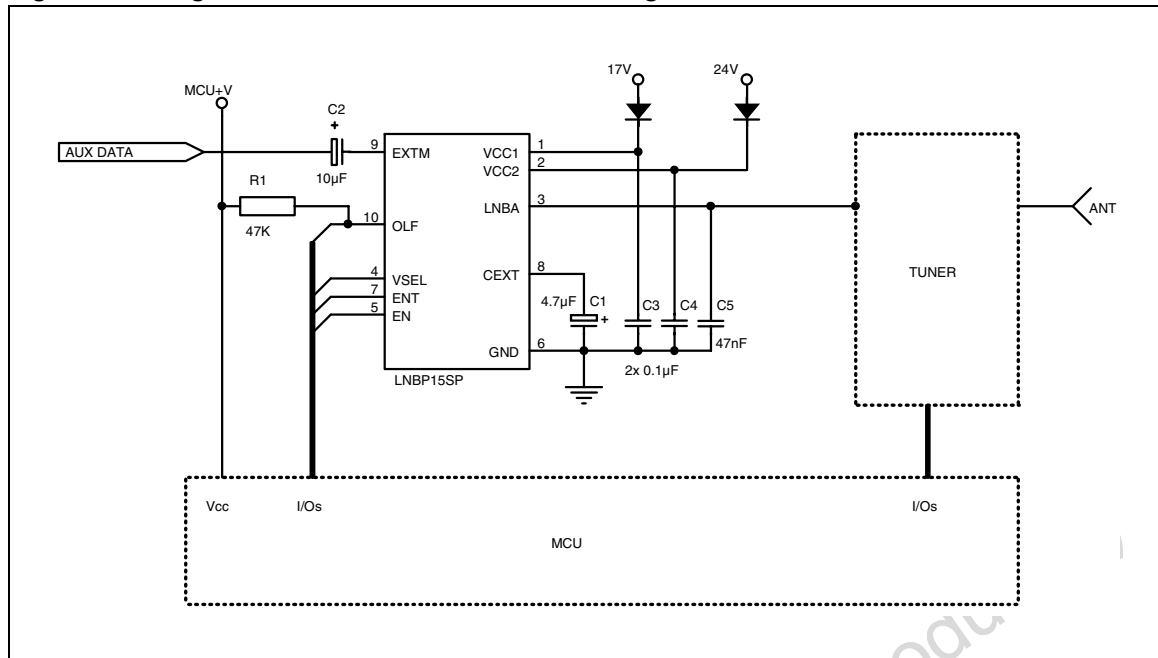

Figure 31. Single antenna receiver with overload diagnostic



Obsolete Product(s) - Obsolete Product

## 8 Package mechanical data

In order to meet environmental requirements, ST offers these devices in ECOPACK<sup>®</sup> packages. These packages have a Lead-free second level interconnect. The category of second Level Interconnect is marked on the package and on the inner box label, in compliance with JEDEC Standard JESD97. The maximum ratings related to soldering conditions are also marked on the inner box label. ECOPACK is an ST trademark. ECOPACK specifications are available at: [www.st.com](http://www.st.com).

Obsolete Product(s) - Obsolete Product(s)

**PowerSO-20 MECHANICAL DATA**

DIM.	mm.			inch		
	MIN.	TYP	MAX.	MIN.	TYP.	MAX.
A			3.60			0.1417
a1	0.10		0.30	0.0039		0.0118
a2			3.30			0.1299
a3	0		0.10	0		0.0039
b	0.40		0.53	0.0157		0.0209
c	0.23		0.32	0.0090		0.0013
D (1)	15.80		16.00	0.6220		0.630
E	13.90		14.50	0.5472		0.5710
e		1.27			0.0500	
e3		11.43			0.4500	
E1 (1)	10.90		11.10	0.4291		0.4370
E2			2.90			0.1141
E3	5.8		6.2	0.2283		0.2441
G	0		0.10	0.0000		0.0039
H	15.5		15.9	0.6102		0.6260
h			1.10			0.0433
L	0.80		1.10	0.0314		0.0433
N			10°			10°
S	0°		8°	0°		8°
T		10.0			0.3937	

(1) "D and E1" do not include mold flash or protusions - Mold flash or protusions shall not exceed 0.15mm (0.006")

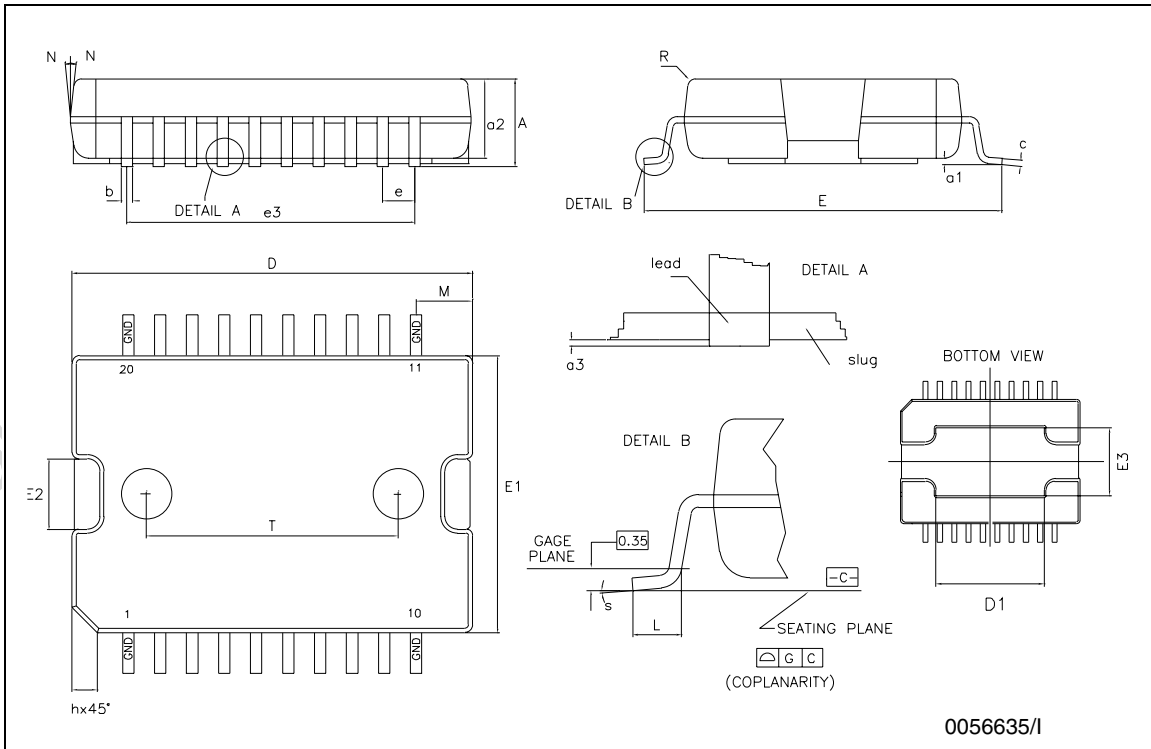

**SO-20 MECHANICAL DATA**

DIM.	mm.			inch		
	MIN.	TYP	MAX.	MIN.	TYP.	MAX.
A	2.35		2.65	0.093		0.104
A1	0.1		0.30	0.004		0.012
B	0.33		0.51	0.013		0.020
C	0.23		0.32	0.009		0.013
D	12.60		13.00	0.496		0.512
E	7.4		7.6	0.291		0.299
e		1.27			0.050	
H	10.00		10.65	0.394		0.419
h	0.25		0.75	0.010		0.030
L	0.4		1.27	0.016		0.050
k	0°		8°	0°		8°
ddd			0.100			0.004

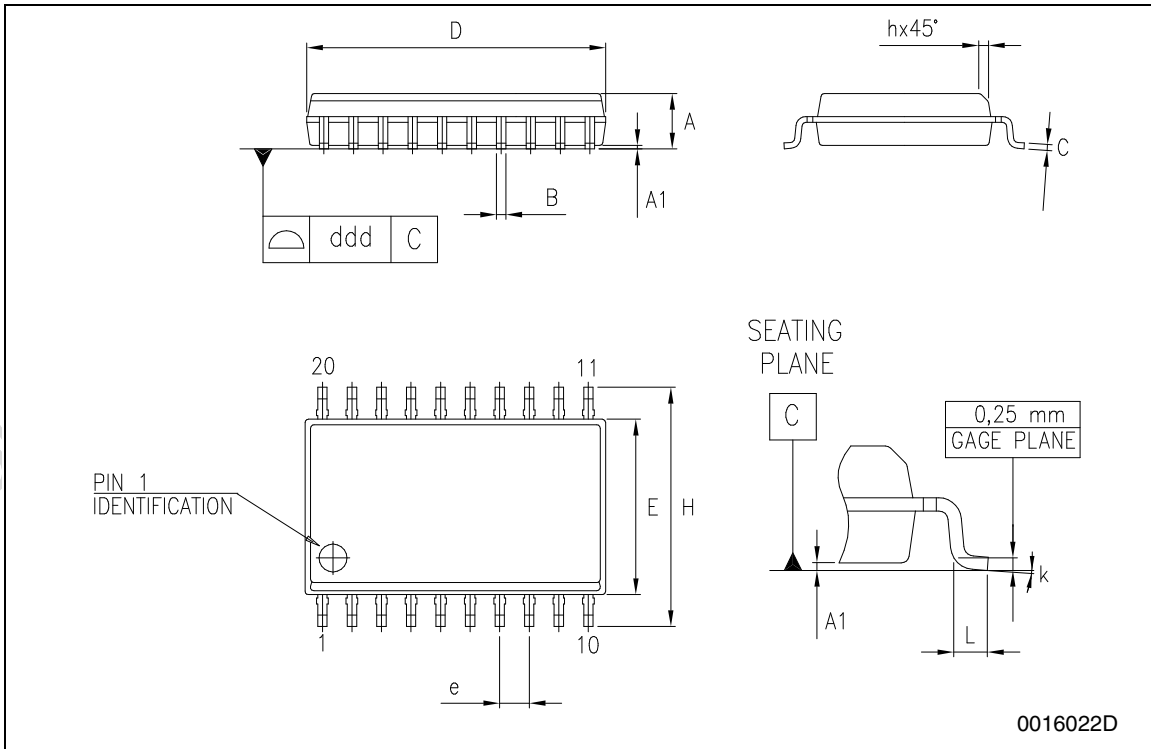

**Tape & Reel PowerSO-20 MECHANICAL DATA**

DIM.	mm.			inch		
	MIN.	TYP	MAX.	MIN.	TYP.	MAX.
A			330			12.992
C	12.8		13.2	0.504		0.519
D	20.2			0.795		
N	60			2.362		
T			30.4			1.197
Ao	15.1		15.3	0.594		0.602
Bo	16.5		16.7	0.650		0.658
Ko	3.8		4.0	0.149		0.157
Po	3.9		4.1	0.153		0.161
P	23.9		24.1	0.941		0.949
W	23.7		24.3	0.933		0.957

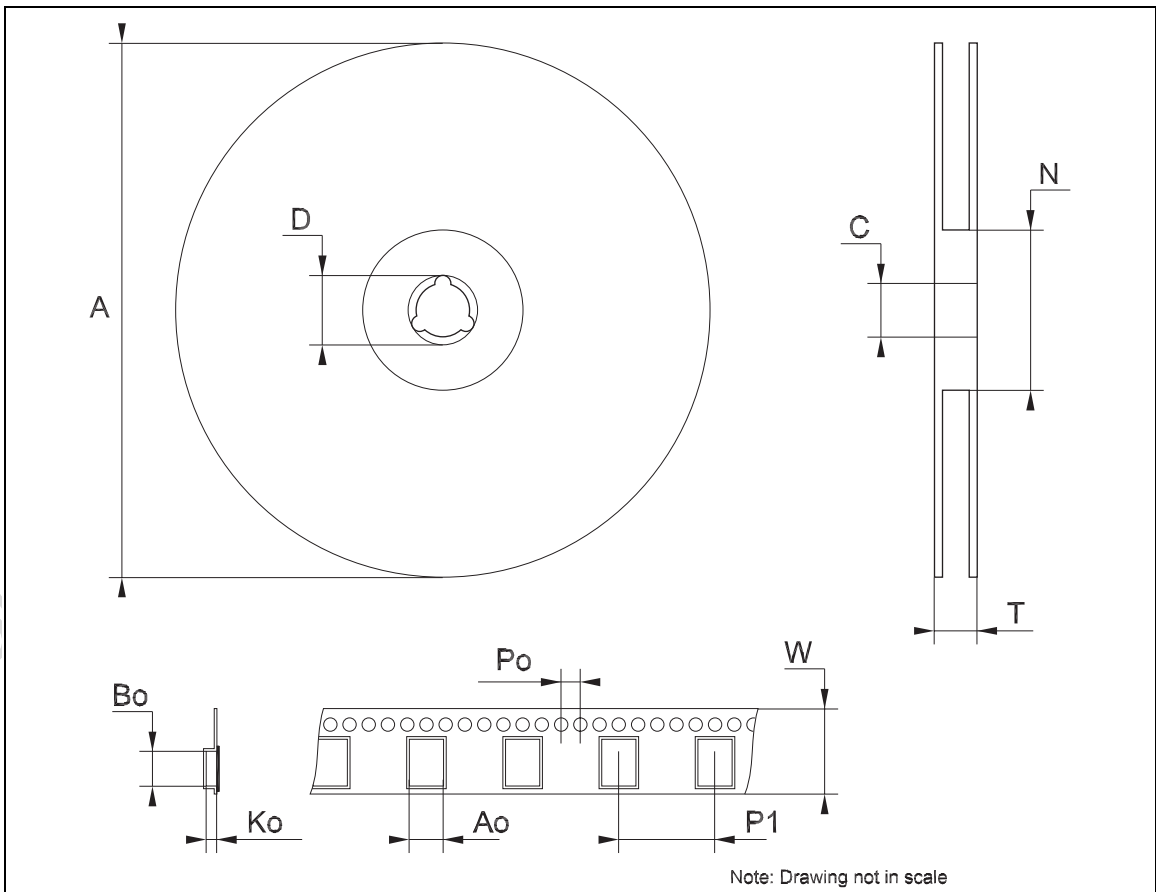

### Tape & Reel SO-20 MECHANICAL DATA

DIM.	mm.			inch		
	MIN.	TYP.	MAX.	MIN.	TYP.	MAX.
A			330			12.992
C	12.8		13.2	0.504		0.519
D	20.2			0.795		
N	60			2.362		
T			30.4			1.197
Ao	10.8		11	0.425		0.433
Bo	13.2		13.4	0.520		0.528
Ko	3.1		3.3	0.122		0.130
Po	3.9		4.1	0.153		0.161
P	11.9		12.1	0.468		0.476

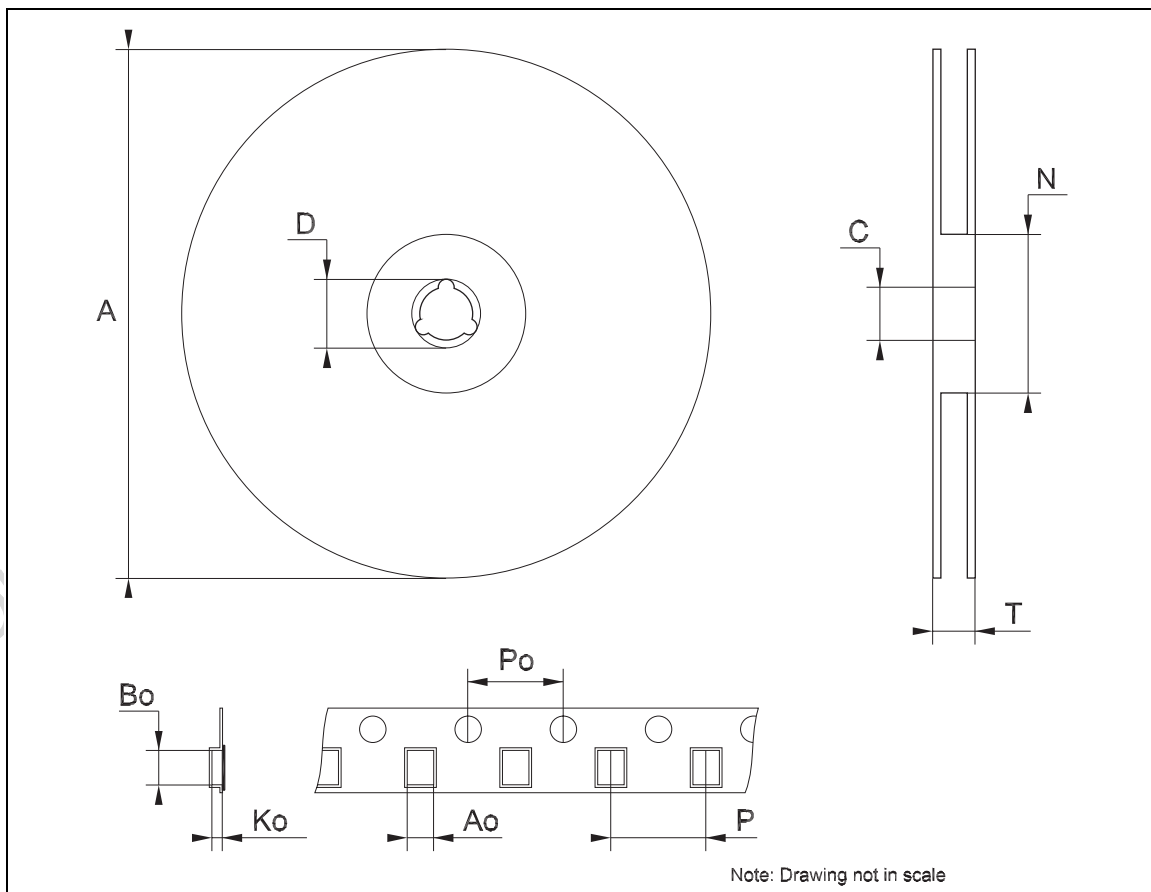

## 9 Revision history

**Table 7. Revision history**

Date	Revision	Changes
20-Sep-2006	7	Order Codes has been updated and new template.
14-Feb-2007	8	Order Codes has been updated.

Obsolete Product(s) - Obsolete Product(s)



**Please Read Carefully:**

Information in this document is provided solely in connection with ST products. STMicroelectronics NV and its subsidiaries ("ST") reserve the right to make changes, corrections, modifications or improvements, to this document, and the products and services described herein at any time, without notice.

All ST products are sold pursuant to ST's terms and conditions of sale.

Purchasers are solely responsible for the choice, selection and use of the ST products and services described herein, and ST assumes no liability whatsoever relating to the choice, selection or use of the ST products and services described herein.

No license, express or implied, by estoppel or otherwise, to any intellectual property rights is granted under this document. If any part of this document refers to any third party products or services it shall not be deemed a license grant by ST for the use of such third party products or services, or any intellectual property contained therein or considered as a warranty covering the use in any manner whatsoever of such third party products or services or any intellectual property contained therein.

**UNLESS OTHERWISE SET FORTH IN ST'S TERMS AND CONDITIONS OF SALE ST DISCLAIMS ANY EXPRESS OR IMPLIED WARRANTY WITH RESPECT TO THE USE AND/OR SALE OF ST PRODUCTS INCLUDING WITHOUT LIMITATION IMPLIED WARRANTIES OF MERCHANTABILITY, FITNESS FOR A PARTICULAR PURPOSE (AND THEIR EQUIVALENTS UNDER THE LAWS OF ANY JURISDICTION), OR INFRINGEMENT OF ANY PATENT, COPYRIGHT OR OTHER INTELLECTUAL PROPERTY RIGHT.**

**UNLESS EXPRESSLY APPROVED IN WRITING BY AN AUTHORIZED ST REPRESENTATIVE, ST PRODUCTS ARE NOT RECOMMENDED, AUTHORIZED OR WARRANTED FOR USE IN MILITARY, AIR CRAFT, SPACE, LIFE SAVING, OR LIFE SUSTAINING APPLICATIONS, NOR IN PRODUCTS OR SYSTEMS WHERE FAILURE OR MALFUNCTION MAY RESULT IN PERSONAL INJURY, DEATH, OR SEVERE PROPERTY OR ENVIRONMENTAL DAMAGE. ST PRODUCTS WHICH ARE NOT SPECIFIED AS "AUTOMOTIVE GRADE" MAY ONLY BE USED IN AUTOMOTIVE APPLICATIONS AT USER'S OWN RISK.**

Resale of ST products with provisions different from the statements and/or technical features set forth in this document shall immediately void any warranty granted by ST for the ST product or service described herein and shall not create or extend in any manner whatsoever, any liability of ST.

ST and the ST logo are trademarks or registered trademarks of ST in various countries.

Information in this document supersedes and replaces all information previously supplied.

The ST logo is a registered trademark of STMicroelectronics. All other names are the property of their respective owners.



© 2007 STMicroelectronics - All rights reserved

STMicroelectronics group of companies

Australia - Belgium - Brazil - Canada - China - Czech Republic - Finland - France - Germany - Hong Kong - India - Israel - Italy - Japan - Malaysia - Malta - Morocco - Singapore - Spain - Sweden - Switzerland - United Kingdom - United States of America

[www.st.com](http://www.st.com)

