

Description

- The CP2103 is a highly-integrated USB-to-UART bridge controller providing a simple solution for updating RS-232 or RS-485 designs to USB using a minimum of components and PCB space. The CP2103 is a functional upgrade to CP2101/2 with new features such as configurable I/O levels (3.3 to 1.8 V) and four general purpose I/O signals for system status and control.

It includes the standard USB 2.0 full-speed function controller, USB transceiver, oscillator, EEPROM and asynchronous serial data bus (UART) with full modem control signals in a compact 5 x 5 mm MLP-28 package. No other external USB components are required.

Example Applications

- Upgrade of RS-232 legacy devices to USB
- Upgrade of RS-485 legacy devices to USB
- USB to RS-232 serial adapter

Virtual Com Port Drivers

- Works with existing COM port applications
- Royalty-free distribution license
- Windows 98SE/2000/XP
- MAC OS-9
- MAC OS-X
- Linux 2.40

USBXpress™ Direct Driver Support

Supply Voltage

- Self-powered: 3.0–3.6 V
- USB bus powered: 4.0–5.25 V

Temperature Range: –40 to +85 °C

Features

USB Function Controller and Transceiver

- USB specification 2.0 compliant; full-speed (12 Mbps)
- Integrated 1024-byte EEPROM for custom Baud rates, vendor ID, etc.
- Integrated transceiver; no external resistors required
- Integrated clock; no external crystal required
- USB suspend states supported via SUSPEND pins

Asynchronous Serial Data Bus (UART)

- All handshaking and modem interface signals
- Data formats supported: 8, 7, 6, 5-bit; 1, 1.5, 2 Stop bits
- Parity: Odd, Even, Mark, Space, No Parity
- Baud rates: 300 bps to 1 Mbps
- 576-byte receive buffer; 640-byte transmit buffer
- Event character support; line break event support
- Four GPIO signals for status and control
- Configurable I/O (3.3 to 1.8 V V_{OH}) using V_{IO} pin
- RS-485 mode with bus transceiver control

Power-On Reset Circuit

Package

- 28-pin QFN (lead-free package)

Ordering Part Numbers

- CP2103-GM

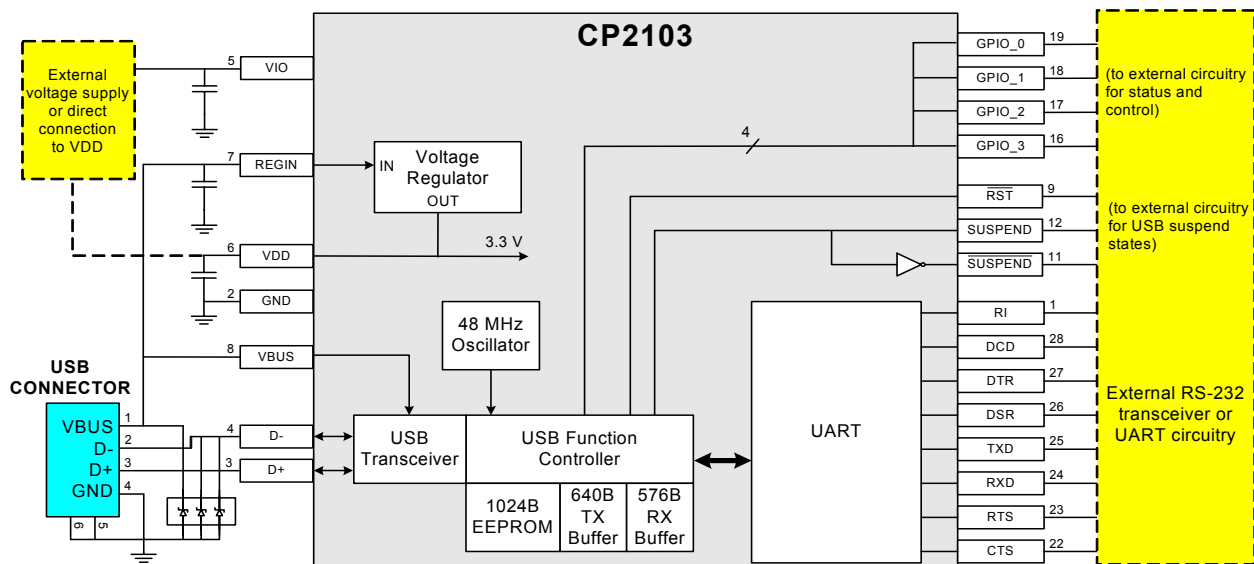

Selected Electrical Specifications

($T_A = -40$ to $+85$ °C, $V_{REGIN} = 5.0$ V unless otherwise specified unless otherwise specified.)

Parameter	Conditions	Min	Typ	Max	Units
Regulator Input Voltage (REGIN)		4.0	—	5.25	V
V_{DD} (Regulator Output)		3.0	3.3	3.6	V
I_{DD} (Regulator Output)		—	75	—	mA
Regulator Bias Current		—	70	—	μ A
Supply Current (from REGIN)	USB active	—	25	—	mA
	USB suspend mode	—	310	—	μ A

Pin Number	Signal	Pin Number	Signal
1	R1	17	GPIO.2
2	GND	18	GPIO.1
3	D+	19	GPIO.0
4	D-	22	CTS
5	VIO	23	RTS
6	VDD	24	RXD
7	REGIN	25	TXD
8	VBUS	26	DSR
9	RST	27	DTR
11	SUSPEND	28	DCD
12	SUSPEND	10, 13-15, 20-21	No Connect
16	GPIO.3		

CP2103EK Evaluation Kit—A complete HW/SW demonstration of the CP2103 chip and associated software drivers.

The CP2103EK shown below includes the following:

- CP2103TB circuit board with USB connector, CP2103 chip, RS-232 transceiver, and DB-9 connector
- CD ROM with device drivers
- USB cable
- RS-232 cable

Package Information

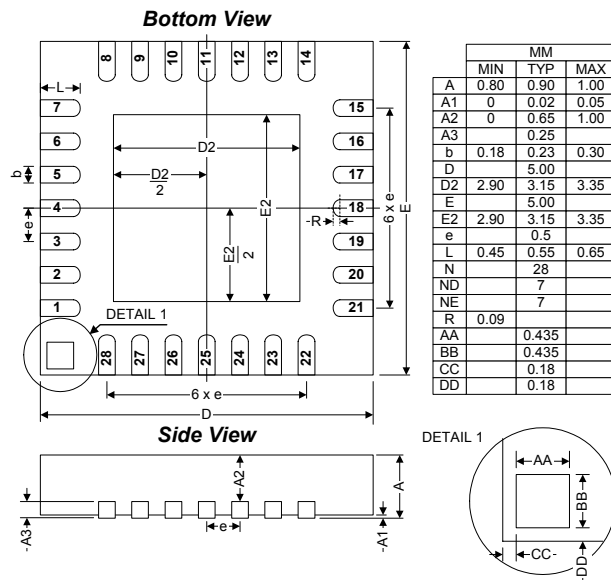

CP2103EK Evaluation Kit

