

DS15EA101

0.15 to 1.5 Gbps Adaptive Cable Equalizer with LOS Detection

General Description

The DS15EA101 is an adaptive equalizer optimized for equalizing data transmitted over copper cables. The DS15EA101 operates over a wide range of data rates from 150 Mbps to 1.5+ Gbps and automatically adapts to equalize any cable length from zero meters to lengths that attenuate the signal by 35 dB at 750 MHz.

The DS15EA101 allows either single-ended or differential input drive. This enables equalization of coaxial cables as well as differential twin-ax and twisted pair cables.

Additional features include an LOS output and an output enable which, when tied together, disable the output when no signal is present.

The DS15EA101 is powered from a single 3.3V supply and consumes 210 mW at 1.5 Gbps. It operates over the full -40°C to $+85^{\circ}\text{C}$ industrial temperature range and is available in a space saving 4 x 4 mm LLP-16 package which allows for high density placement of components in multi-channel applications.

Features

- Automatic equalization of coaxial, twin-ax and twisted pair cables
- High data rates: 150 Mbps to 1.5+ Gbps
- Up to 35 dB of boost at 750 MHz
- LOS detection and output enable
- Single-ended or differential input
- 50Ω differential outputs
- Low power operation, 210 mW (typ) at 1.5 Gbps
- Industrial -40°C to $+85^{\circ}\text{C}$ temperature
- Space-saving 4 x 4 mm LLP-16 package

Applications

- Cable extension applications
- Security cameras
- Remote LCDs and LED panels
- Data recovery equalization

Typical Application

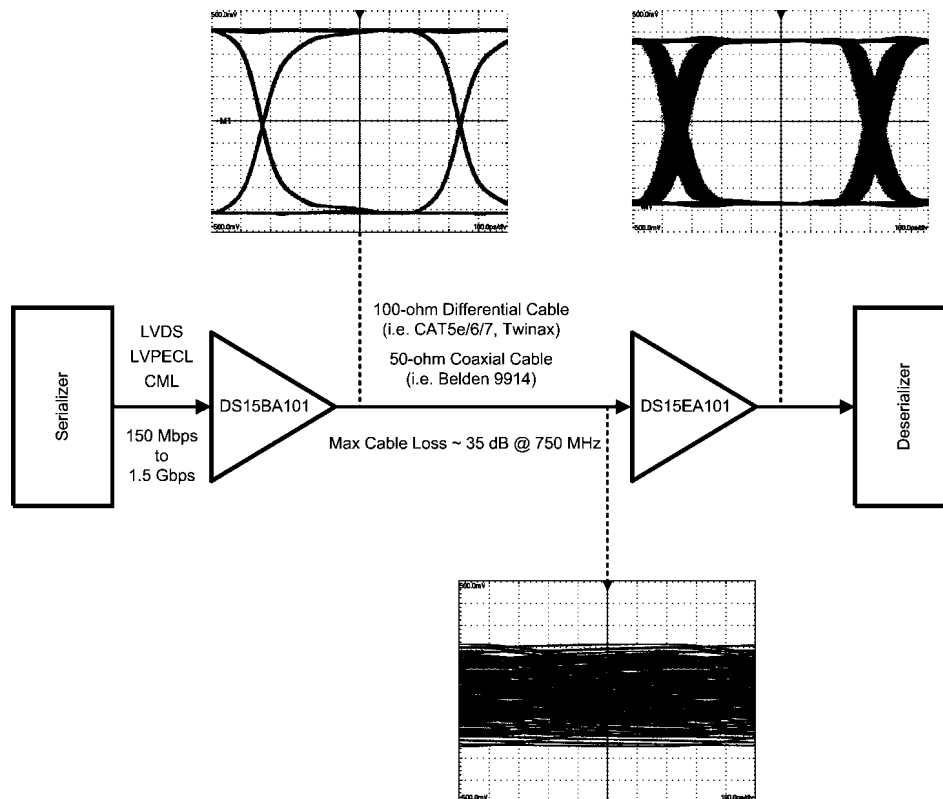

20201701

Absolute Maximum Ratings (Note 1)

Supply Voltage	-0.5V to 3.6V
Input Voltage (all inputs)	-0.3V to $V_{CC}+0.3V$
Storage Temperature Range	-65°C to +150°C
Junction Temperature	+150°C
Lead Temperature (Soldering 4 Sec)	+260°C
Package Thermal Resistance	
θ_{JA} SQA16A	+42.1°C/W
θ_{JC} SQA16A	+8.2°C/W
ESD Rating (HBM)	8 kV
ESD Rating (MM)	250V

Recommended Operating Conditions

Supply Voltage (V_{CC})	3.3V \pm 5%
Input Coupling Capacitance	1.0 μ F
Loop Capacitor (Connected between CAP+ and CAP-)	1.0 μ F
Operating Free Air Temperature (T_A)	-40°C to +85°C

DC Electrical Characteristics

Over Supply Voltage and Operating Temperature ranges, unless otherwise specified (Notes 2, 3).

Symbol	Parameter	Conditions	Reference	Min	Typ	Max	Units
V_{CM}	Input Common Mode Voltage		IN+, IN-		1.9		V
V_{IN}	Input Voltage	(Notes 4, 6)				950	mV _{P-P}
V_{OS}	Output Common Mode Voltage		OUT+, OUT-		$V_{CC} - V_{OUT}/2$		V
V_{OUT}	Output Voltage Swing	50 Ω load, differential				750	mV _{P-P}
V_{LOS}	LOS Output Voltage	Valid signal not present	LOS	2.6			V
		Valid signal present				0.4	V
$V_{IN(EN)}$	\overline{EN} Input Voltage	Min to disable outputs	\overline{EN}	3.0			V
		Max to enable outputs				0.8	V
I_{CC}	Supply Current	(Note 7)			63	77	mA

AC Electrical Characteristics

Over Supply Voltage and Operating Temperature ranges, unless otherwise specified (Note 3).

Symbol	Parameter	Conditions	Reference	Min	Typ	Max	Units
BR_{IN}	Input Data Rate		IN+, IN-	150		1500	Mbps
t_{TRJ}	Total Residual Jitter @ BER-12 (Note 8)	1.5 Gbps 25m CAT5e (Belden 1700A), (Note 3)			0.25		UI
		1.0 Gbps 50m CAT5e (Belden 1700A), (Note 3)			0.25		UI
		0.5 Gbps 100m CAT5e (Belden 1700A), (Note 3)			0.25		UI
		1.5 Gbps 50m CAT7 (Siemon Tera), (Note 3)			0.25		UI
		1.5 Gbps 75m CAT7 (Siemon Tera), (Note 3)			0.30		UI
		1.0 Gbps 100m CAT7 (Siemon Tera), (Note 3)			0.40		UI
		1.5 Gbps 200m Belden 9914, (Note 3)			0.25		UI
t_{TLH}	Transition Time from Low to High	20% – 80%, (Note 4)	OUT+, OUT-		100	220	ps
t_{THL}	Transition Time from High to Low	20% – 80%, (Note 4)			100	220	ps
R_{OUT}	Output Resistance	single-ended, (Note 5)			50		Ω

Note 1: "Absolute Maximum Ratings" are those parameter values beyond which the life and operation of the device cannot be guaranteed. The stating herein of these maximums shall not be construed to imply that the device can or should be operated at or beyond these values. The table of "Electrical Characteristics" specifies acceptable device operating conditions.

Note 2: Current flow into device pins is defined as positive. Current flow out of device pins is defined as negative. All voltages are stated referenced to 0 volts.

Note 3: Typical values are stated for $V_{CC} = +3.3V$ and $T_A = +25^\circ C$.

Note 4: Specification is guaranteed by characterization.

Note 5: Specification is guaranteed by design.

Note 6: The maximum input voltage amplitude assumes a DC-balanced signal.

Note 7: Supply current depends on the amount of cable being equalized. The current is highest for short cable and decreases as the cable length is increased.

Note 8: The total residual jitter at BER-12 was calculated as $DJ+14.1xRJ$, where DJ is deterministic jitter and RJ is random jitter. The jitter is expressed as a portion of a unit interval (UI). One UI is a reciprocal of a bit rate (or data rate). For example, a 1.5 Gbps (gigabit per second) signal has $1 / (1.5 \text{ Gb/s}) = 666.67$ ps (picosecond) unit interval. A 0.25 UI jitter is equivalent to $0.25 \times 666.67 \text{ ps} = 166.67 \text{ ps}$.

Connection Diagram

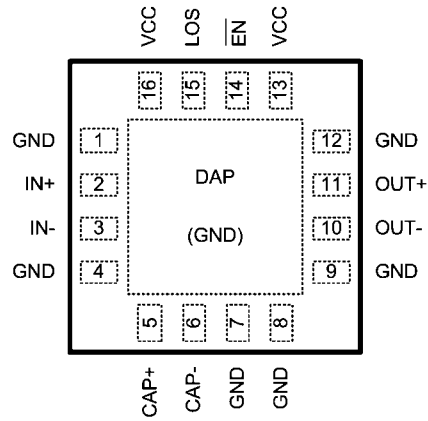

20201703

16-Pad LLP
Order Number DS15EA101SQ
See NS Package Number SQA16A

Pin Descriptions

Pin #	Name	Description
1	GND	Ground pin.
2	IN+	Non-inverting input pin.
3	IN-	Inverting input pin.
4	GND	Ground pin.
5	CAP+	Loop filter positive pin.
6	CAP-	Loop filter negative pin.
7	GND	Ground pin.
8	GND	Ground pin.
9	GND	Ground pin.
10	OUT-	Inverting output pin.
11	OUT+	Non-inverting output pin.
12	GND	Ground pin.
13	VCC	Power supply pin.
14	EN	Output enable pin.
15	LOS	Los of signal circuitry output pin.
16	VCC	Power supply pin.

Device Operation

INPUT INTERFACING

The DS15EA101 accepts either differential or single-ended input. The input must be AC coupled. Transformer coupling is not supported. If the signal is differential, its amplitude must be 800 mVp-p $\pm 10\%$ (400 mV single-ended). If the signal is single-ended, its amplitude must be 800 mV $\pm 10\%$.

OUTPUT INTERFACING

The DS15EA101 uses current mode outputs. They are internally terminated with 50Ω . The following two figures illustrate

typical DC-coupled interface to common differential receivers and assume that the receivers have high impedance inputs. While most receivers have an input common mode voltage range that can accommodate CML signals, it is recommended to check respective receiver's datasheet prior to implementing the suggested interface implementations.

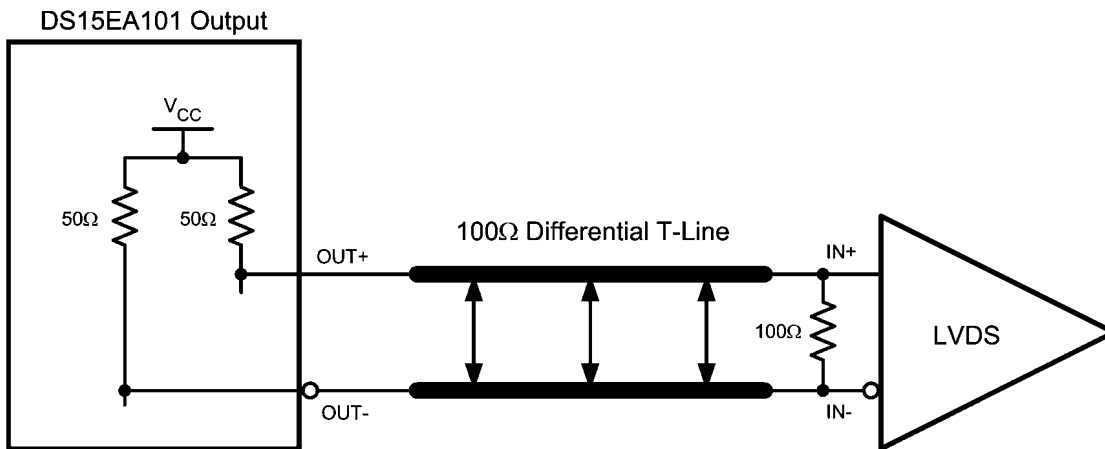

Typical DS15EA101 Output DC-Coupled Interface to an LVDS Receiver

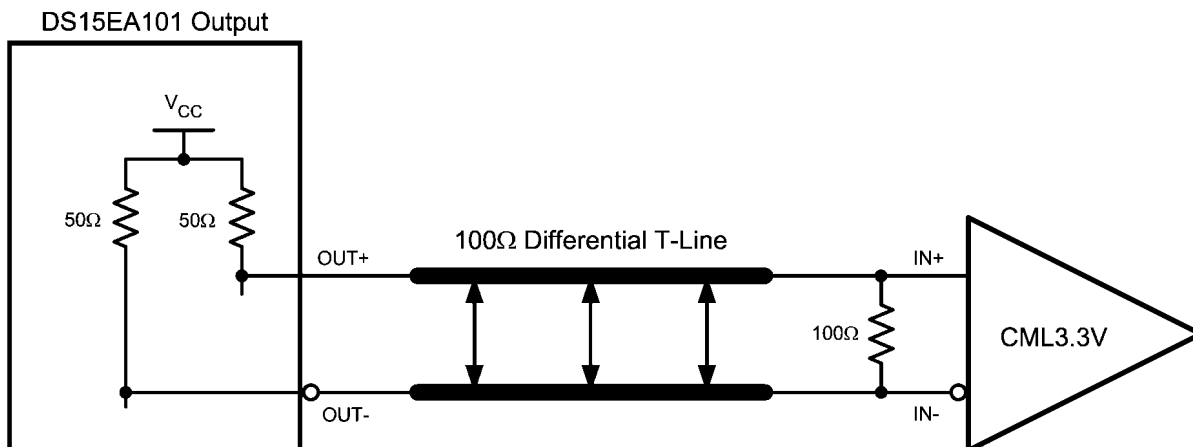

Typical DS15EA101 Output DC-Coupled Interface to a CML Receiver

CABLE EXTENDER APPLICATION

The DS15EA101 together with the DS15BA101 form a cable extender chipset optimized for extending serial data streams from serializer/deserializer (SerDes) pairs and field programmable gate arrays (FPGAs) over 100Ω differential

(i.e. CAT5e/6/7 and twinax) and 50Ω coaxial cables. Setting correct DS15BA101 output amplitude and proper cable termination are keys for optimal operation. The following two figures show recommended chipset configuration for 100Ω differential and 50Ω coaxial cables.

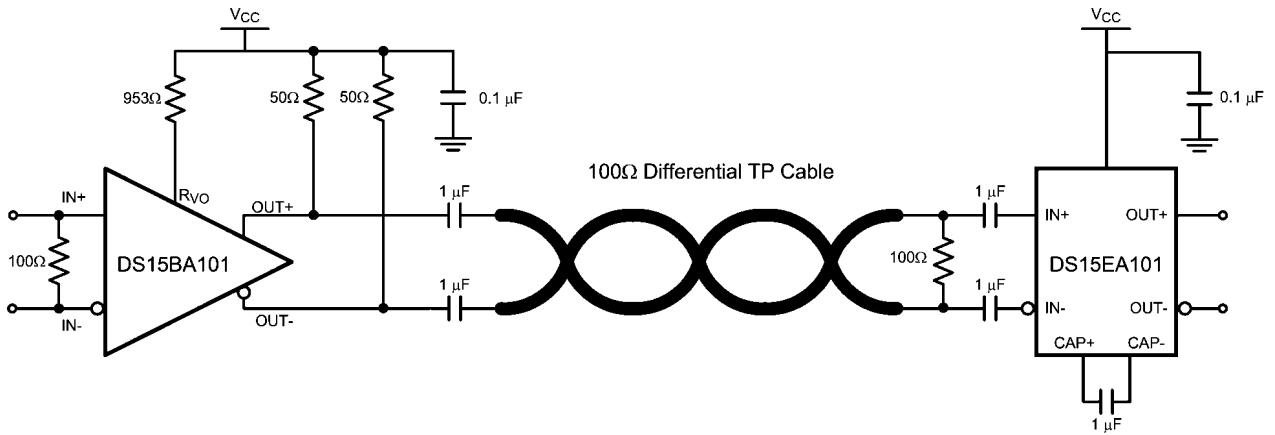

Cable Extender Chipset Connection Diagram for 100Ω Differential Cables

20201705

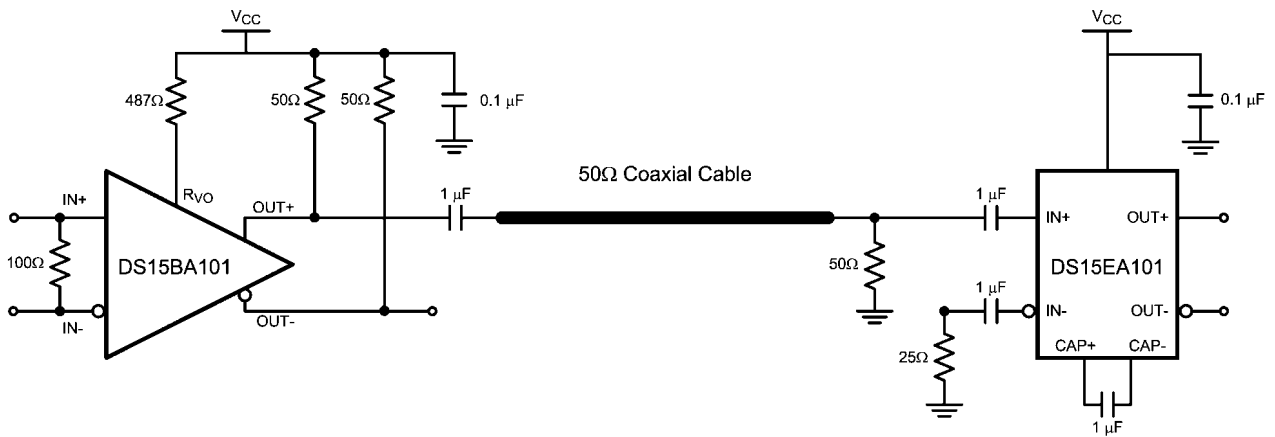

Cable Extender Chipset Connection Diagram for 50Ω Coaxial Cables

20201706

REFERENCE DESIGN

There is a complete reference design (P/N: DriveCable02EVK) available for evaluation of the cable extender chipset (DS15BA101 and DS15EA101). For more information visit <http://www.national.com/appinfo/lvds/drivecable02evk.html>.

Typical Performance

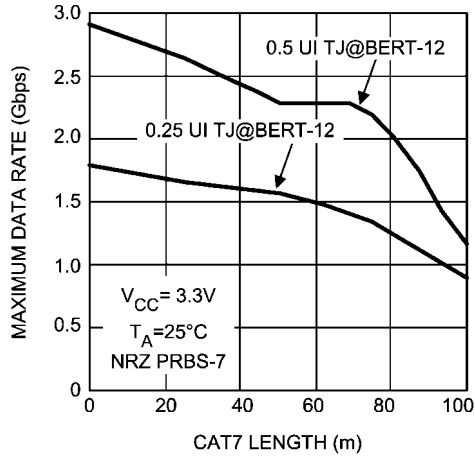

20201710
Maximum Data Rate as a Function of CAT7 (Siemon CAT7 Tera) Length

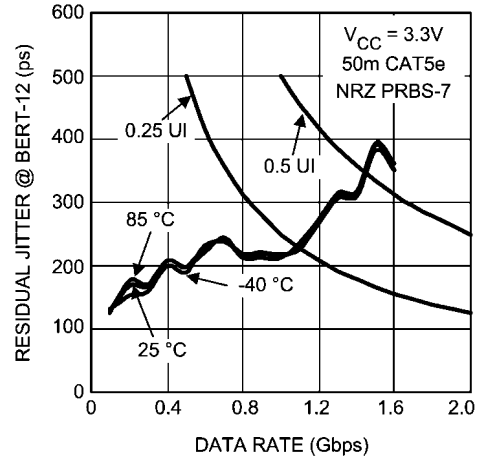

20201714
Residual Jitter as a Function of Data Rate and Temperature for the Chipset with 50m CAT5e

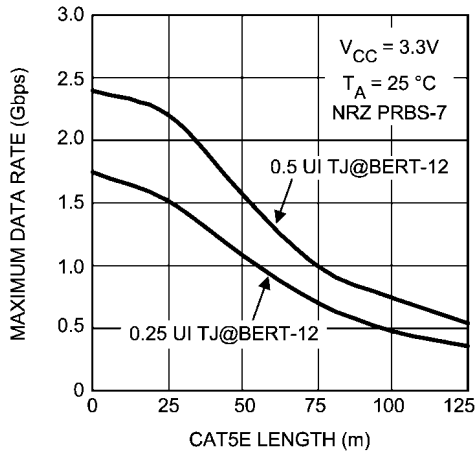

20201711
Maximum Data Rate as a Function of CAT5e (Belden 1700A) Length

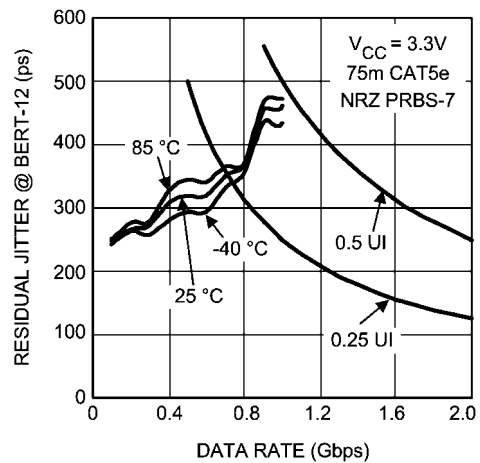

20201715
Residual Jitter as a Function of Data Rate and Temperature for the Chipset with 75m CAT5e

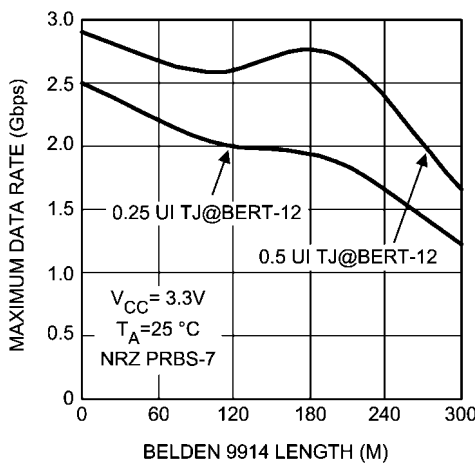

20201712
Maximum Data Rate as a Function of 50Ω Coaxial (Belden 9914) Length

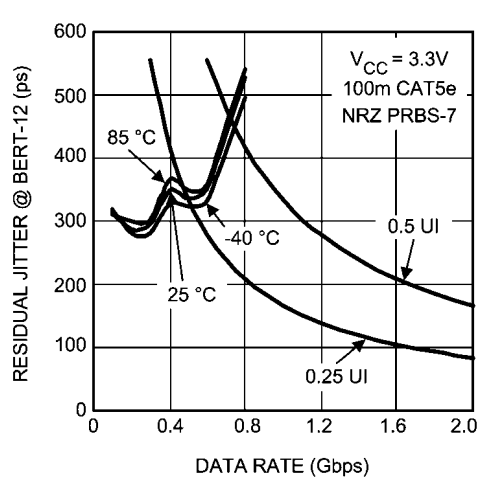

20201716
Residual Jitter as a Function of Data Rate and Temperature for the Chipset with 100m CAT5e

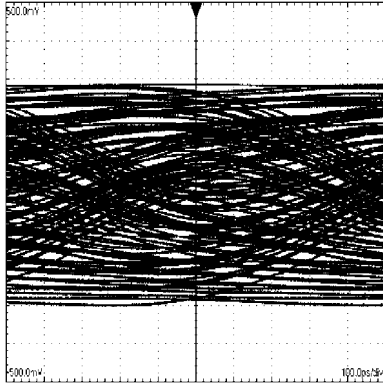

20201720
A 1.5 Gbps NRZ PRBS-7 After 25m CAT5e
 V:100 mV / DIV, H:100 ps / DIV

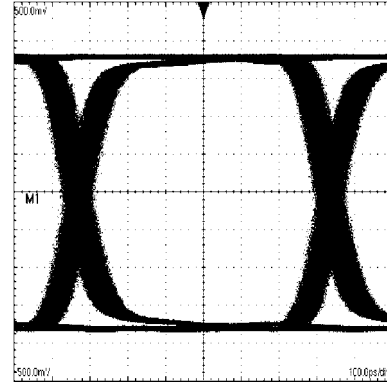

20201721
An Equalized 1.5 Gbps NRZ PRBS-7 After 25m CAT5e
 V:100 mV / DIV, H:100 ps / DIV

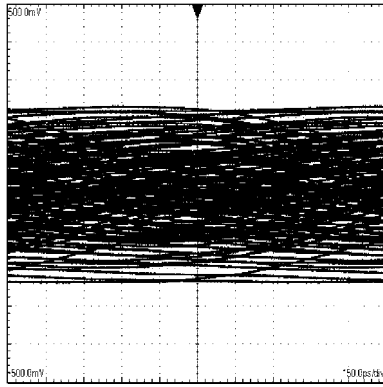

20201722
A 1.0 Gbps NRZ PRBS-7 After 50m CAT5e
 V:100 mV / DIV, H:150 ps / DIV

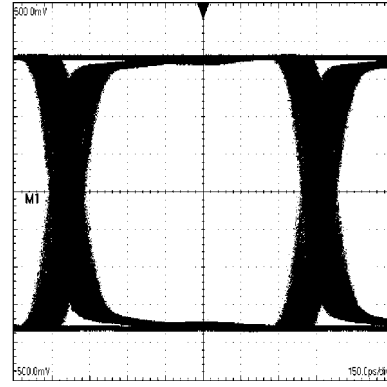

20201723
An Equalized 1.0 Gbps NRZ PRBS-7 After 50m CAT5e
 V:100 mV / DIV, H:150 ps / DIV

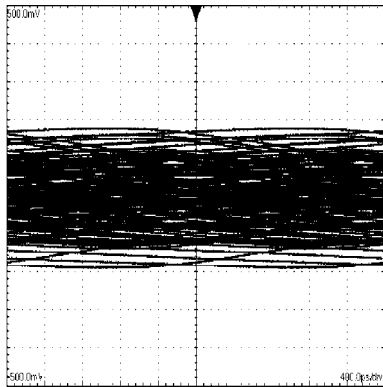

20201724
A 0.5 Gbps NRZ PRBS-7 After 100m CAT5e
 V:100 mV / DIV, H:400 ps / DIV

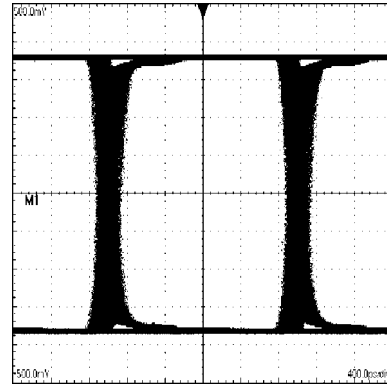

20201725
An Equalized 0.5 Gbps NRZ PRBS-7 After 100m CAT5e
 V:100 mV / DIV, H:400 ps / DIV

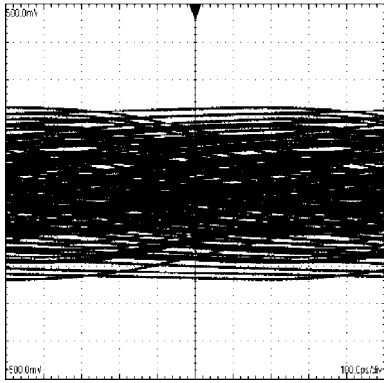

20201726
A 1.5 Gbps NRZ PRBS-7 After 50m CAT7
 V:100 mV / DIV, H:100 ps / DIV

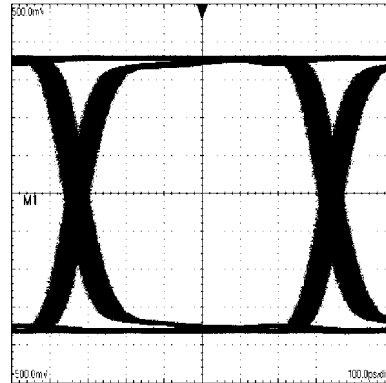

20201727
An Equalized 1.5 Gbps NRZ PRBS-7 After 50m CAT7
 V:100 mV / DIV, H:100 ps / DIV

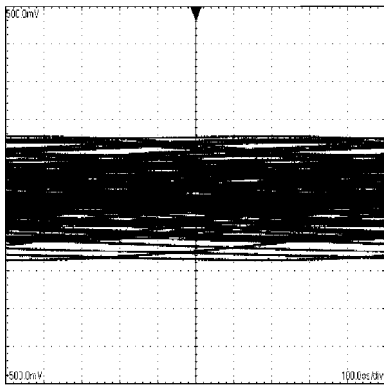

20201728
A 1.5 Gbps NRZ PRBS-7 After 75m CAT7
 V:100 mV / DIV, H:100 ps / DIV

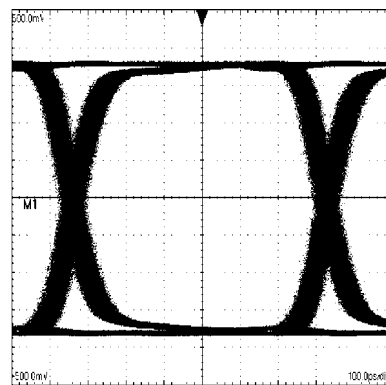

20201729
An Equalized 1.5 Gbps NRZ PRBS-7 After 75m CAT7
 V:100 mV / DIV, H:100 ps / DIV

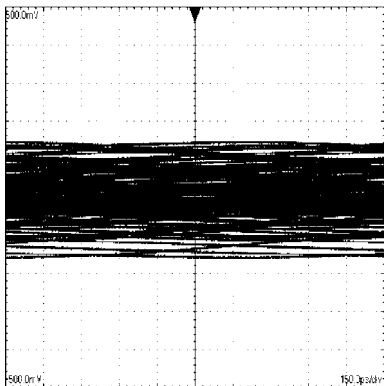

20201730
A 1.0 Gbps NRZ PRBS-7 After 100m CAT7
 V:100 mV / DIV, H:150 ps / DIV

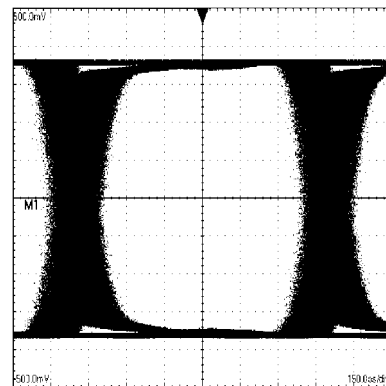

20201731
An Equalized 1.0 Gbps NRZ PRBS-7 After 100m CAT7
 V:100 mV / DIV, H:150 ps / DIV

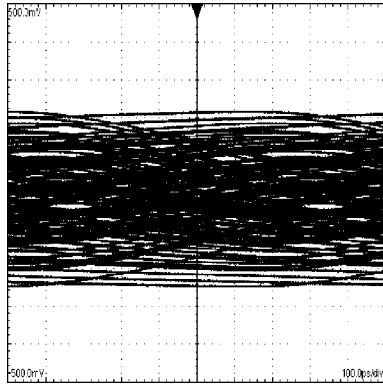

A 1.5 Gbps NRZ PRBS-7 After 200m Belden 9914
V:100 mV / DIV, H:100 ps / DIV

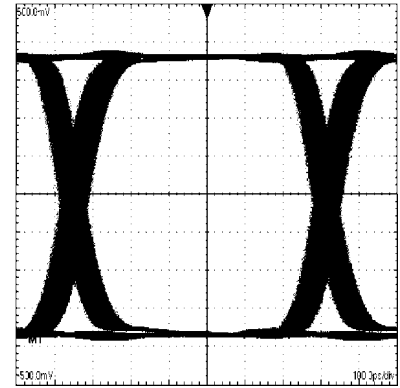

An Equalized 1.5 Gbps NRZ PRBS-7 After 200m Belden 9914
V:100 mV / DIV, H:100 ps / DIV

Physical Dimensions inches (millimeters) unless otherwise noted

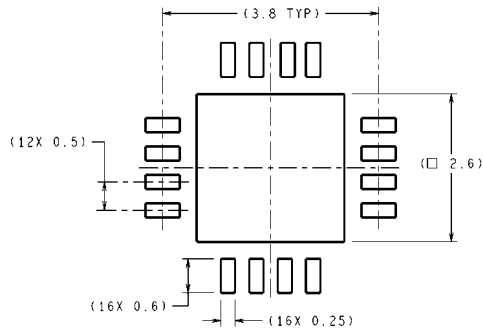

DIMENSIONS ARE IN MILLIMETERS
DIMENSIONS IN () FOR REFERENCE ONLY

RECOMMENDED LAND PATTERN

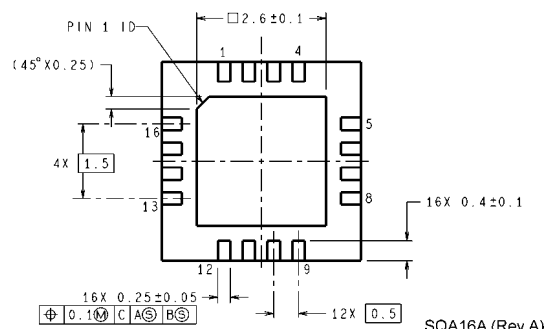
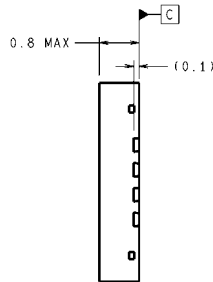
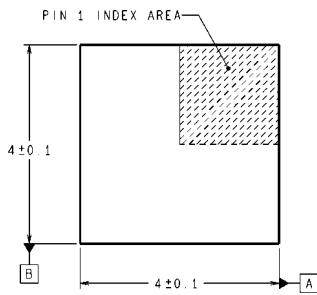

SQA16A (Rev A)

16-Pin LLP
Order Number DS15EA101SQ
NS Package Number SQA16A
(See AN-1187 for PCB Design and Assembly Recommendations)

Notes

For more National Semiconductor product information and proven design tools, visit the following Web sites at:

Products		Design Support	
Amplifiers	www.national.com/amplifiers	WEBENCH® Tools	www.national.com/webench
Audio	www.national.com/audio	App Notes	www.national.com/appnotes
Clock and Timing	www.national.com/timing	Reference Designs	www.national.com/refdesigns
Data Converters	www.national.com/adc	Samples	www.national.com/samples
Interface	www.national.com/interface	Eval Boards	www.national.com/evalboards
LVDS	www.national.com/lvds	Packaging	www.national.com/packaging
Power Management	www.national.com/power	Green Compliance	www.national.com/quality/green
Switching Regulators	www.national.com/switchers	Distributors	www.national.com/contacts
LDOs	www.national.com/ldo	Quality and Reliability	www.national.com/quality
LED Lighting	www.national.com/led	Feedback/Support	www.national.com/feedback
Voltage Reference	www.national.com/vref	Design Made Easy	www.national.com/easy
PowerWise® Solutions	www.national.com/powerwise	Solutions	www.national.com/solutions
Serial Digital Interface (SDI)	www.national.com/sdi	Mil/Aero	www.national.com/milaero
Temperature Sensors	www.national.com/tempsensors	SolarMagic™	www.national.com/solarmagic
Wireless (PLL/VCO)	www.national.com/wireless	Analog University®	www.national.com/AU

THE CONTENTS OF THIS DOCUMENT ARE PROVIDED IN CONNECTION WITH NATIONAL SEMICONDUCTOR CORPORATION ("NATIONAL") PRODUCTS. NATIONAL MAKES NO REPRESENTATIONS OR WARRANTIES WITH RESPECT TO THE ACCURACY OR COMPLETENESS OF THE CONTENTS OF THIS PUBLICATION AND RESERVES THE RIGHT TO MAKE CHANGES TO SPECIFICATIONS AND PRODUCT DESCRIPTIONS AT ANY TIME WITHOUT NOTICE. NO LICENSE, WHETHER EXPRESS, IMPLIED, ARISING BY ESTOPPEL OR OTHERWISE, TO ANY INTELLECTUAL PROPERTY RIGHTS IS GRANTED BY THIS DOCUMENT.

TESTING AND OTHER QUALITY CONTROLS ARE USED TO THE EXTENT NATIONAL DEEMS NECESSARY TO SUPPORT NATIONAL'S PRODUCT WARRANTY. EXCEPT WHERE MANDATED BY GOVERNMENT REQUIREMENTS, TESTING OF ALL PARAMETERS OF EACH PRODUCT IS NOT NECESSARILY PERFORMED. NATIONAL ASSUMES NO LIABILITY FOR APPLICATIONS ASSISTANCE OR BUYER PRODUCT DESIGN. BUYERS ARE RESPONSIBLE FOR THEIR PRODUCTS AND APPLICATIONS USING NATIONAL COMPONENTS. PRIOR TO USING OR DISTRIBUTING ANY PRODUCTS THAT INCLUDE NATIONAL COMPONENTS, BUYERS SHOULD PROVIDE ADEQUATE DESIGN, TESTING AND OPERATING SAFEGUARDS.

EXCEPT AS PROVIDED IN NATIONAL'S TERMS AND CONDITIONS OF SALE FOR SUCH PRODUCTS, NATIONAL ASSUMES NO LIABILITY WHATSOEVER, AND NATIONAL DISCLAIMS ANY EXPRESS OR IMPLIED WARRANTY RELATING TO THE SALE AND/OR USE OF NATIONAL PRODUCTS INCLUDING LIABILITY OR WARRANTIES RELATING TO FITNESS FOR A PARTICULAR PURPOSE, MERCHANTABILITY, OR INFRINGEMENT OF ANY PATENT, COPYRIGHT OR OTHER INTELLECTUAL PROPERTY RIGHT.

LIFE SUPPORT POLICY

NATIONAL'S PRODUCTS ARE NOT AUTHORIZED FOR USE AS CRITICAL COMPONENTS IN LIFE SUPPORT DEVICES OR SYSTEMS WITHOUT THE EXPRESS PRIOR WRITTEN APPROVAL OF THE CHIEF EXECUTIVE OFFICER AND GENERAL COUNSEL OF NATIONAL SEMICONDUCTOR CORPORATION. As used herein:

Life support devices or systems are devices which (a) are intended for surgical implant into the body, or (b) support or sustain life and whose failure to perform when properly used in accordance with instructions for use provided in the labeling can be reasonably expected to result in a significant injury to the user. A critical component is any component in a life support device or system whose failure to perform can be reasonably expected to cause the failure of the life support device or system or to affect its safety or effectiveness.

National Semiconductor and the National Semiconductor logo are registered trademarks of National Semiconductor Corporation. All other brand or product names may be trademarks or registered trademarks of their respective holders.

Copyright© 2009 National Semiconductor Corporation

For the most current product information visit us at www.national.com



National Semiconductor Americas Technical Support Center
 Email: support@nsc.com
 Tel: 1-800-272-9959

National Semiconductor Europe Technical Support Center
 Email: europe.support@nsc.com
 German Tel: +49 (0) 180 5010 771
 English Tel: +44 (0) 870 850 4288

National Semiconductor Asia Pacific Technical Support Center
 Email: ap.support@nsc.com

National Semiconductor Japan Technical Support Center
 Email: jpn.feedback@nsc.com