

## Smartcard interface

### Features

- Designed to be compatible with the NDS conditional access system
- IC card interface
- 3 or 5 V supply for the IC ( $V_{DD}$  and GND)
- Three specifically protected half-duplex bi-directional buffered I/O lines to card contacts C4, C7 and C8
- DC-DC converter for  $V_{CC}$  generation separately powered from a  $5\text{ V} \pm 20\%$  supply ( $V_{DDP}$  and PGND)
- $3\text{ or }5\text{ V} \pm 5\%$  regulated card supply voltage ( $V_{CC}$ ) with appropriate decoupling has the following capabilities:
  - $I_{CC} < 80\text{ mA}$  at  $V_{DDP} = 4\text{ to }6.5\text{ V}$
  - Handles current spikes of  $40\text{ nA}$  up to  $20\text{ MHz}$
  - Controls rise and fall times
  - Filtered overload detection at approximately  $120\text{ mA}$
- Thermal and short-circuit protection on all card contacts
- Automatic activation and deactivation sequences; initiated by software or by hardware in the event of a short-circuit, card take-off, overheating,  $V_{DD}$  or  $V_{DDP}$  drop-out
- Enhanced ESD protection on card side ( $> 6\text{ kV}$ )
- $26\text{ MHz}$  integrated crystal oscillator
- Clock generation for cards up to  $20\text{ MHz}$  (divided by 1, 2, 4 or 8 through CLKDIV1 and CLKDIV2 signals) with synchronous frequency changes
- Non-inverted control of RST via pin RSTIN

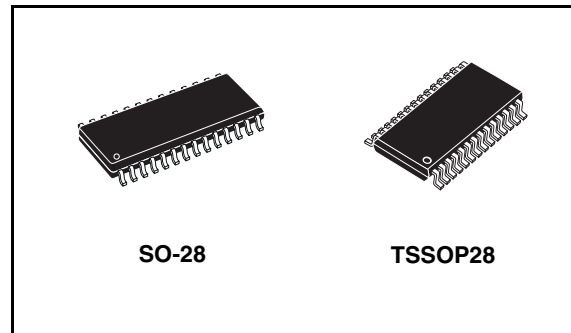

- ISO 7816, GSM11.11 and EMV (payment systems) compatibility
- Supply supervisor for spike-killing during power-on and power-off and power-on reset (threshold fixed internally or externally by a resistor bridge)
- Built-in debounce on card presence contacts
- One multiplexed status signal off

### Description

The ST8024 is a complete low cost analog interface for asynchronous 3 V and 5 V smart cards. It can be placed between the card and the microcontroller with few external components to perform all supply protection and control functions. ST8024 is a direct replacement of ST8004.

Main applications are: smartcard readers for set-top-box, IC card readers for banking, identification, pay TV.

**Table 1. Device summary**

Order codes	Temperature range	Packages	Packaging
ST8024CDR	- 25 to 85 °C	SO-28 (tape and reel)	1000 parts per reel
ST8024CTR	- 25 to 85 °C	TSSOP28 (tape and reel)	2500 parts per reel

# Contents

<b>1</b>	<b>Diagram</b> .....	<b>5</b>
<b>2</b>	<b>Pin configuration</b> .....	<b>6</b>
<b>3</b>	<b>Maximum ratings</b> .....	<b>8</b>
<b>4</b>	<b>Electrical characteristics</b> .....	<b>9</b>
<b>5</b>	<b>Functional description</b> .....	<b>16</b>
5.1	Power supply .....	16
5.2	Voltage supervisor .....	16
5.2.1	Without external divider on pin PORADJ .....	16
5.2.2	With an external divider on pin PORADJ .....	17
5.2.3	Application examples .....	17
5.3	Clock circuitry .....	17
5.4	I/O transceivers .....	18
5.5	Inactive mode .....	19
5.6	Activation sequence .....	19
5.7	Active mode .....	21
5.8	Deactivation sequence .....	21
5.9	V <sub>CC</sub> generator .....	21
5.10	Fault detection .....	22
<b>6</b>	<b>Application</b> .....	<b>24</b>
<b>7</b>	<b>Package mechanical data</b> .....	<b>25</b>
<b>8</b>	<b>Revision history</b> .....	<b>30</b>

## List of tables

Table 1.	Device summary . . . . .	1
Table 2.	Pin description . . . . .	6
Table 3.	Absolute maximum ratings . . . . .	8
Table 4.	Thermal data . . . . .	8
Table 5.	Recommended operating conditions . . . . .	8
Table 6.	Electrical characteristics over recommended operating condition . . . . .	9
Table 7.	Step-up converter . . . . .	10
Table 8.	Card supply voltage characteristics . . . . .	10
Table 9.	Crystal connection (pins XTAL1 and XTAL2) . . . . .	11
Table 10.	Data lines (pins I/O, I/OUC, AUX1, AUX2, AUX1UC AND AUX2UC). . . . .	11
Table 11.	Data lines to card reader (pins I/O, AUX1 AND AUX2 with integrated 11 k $\Omega$ pull-up resistor to V <sub>CC</sub> . . . . .	11
Table 12.	Data lines to microcontroller (pins I/OUC, AUX1UC AND AUX2UC with integrated 11 k $\Omega$ pull-up resistor to V <sub>DD</sub> . . . . .	12
Table 13.	Internal oscillator. . . . .	12
Table 14.	Reset output to card reader (pin RST) . . . . .	13
Table 15.	Clock output to card reader (pin CLK) . . . . .	13
Table 16.	Control inputs (pins CLKDIV1, CLKDIV2, CMDVCC, RSTIN and 5 V / 3 V . . . . .	14
Table 17.	Card presence inputs (pins PRES and PRES) . . . . .	14
Table 18.	Interrupt output (pin OFF NMOS drain with integrated 20 k $\Omega$ pull-up resistor to V <sub>DD</sub> ); . . .	14
Table 19.	Protection and limitation . . . . .	14
Table 20.	Timing . . . . .	15
Table 21.	Clock frequency selection . . . . .	18
Table 22.	Card presence indicator . . . . .	19
Table 23.	Document revision history . . . . .	30

## List of figures

Figure 1.	Block diagram . . . . .	5
Figure 2.	Pin connections . . . . .	6
Figure 3.	Definition of output and input transition times . . . . .	15
Figure 4.	Voltage supervisor . . . . .	17
Figure 5.	Activation sequence using RSTIN and CMDVCC . . . . .	20
Figure 6.	Activation sequence at $t_3$ . . . . .	20
Figure 7.	Deactivation sequence . . . . .	21
Figure 8.	Behavior of OFF, CMDVCC, PRES and $V_{CC}$ . . . . .	22
Figure 9.	Emergency deactivation sequence (card extraction) . . . . .	23
Figure 10.	Application diagram . . . . .	24

# 1 Diagram

Figure 1. Block diagram

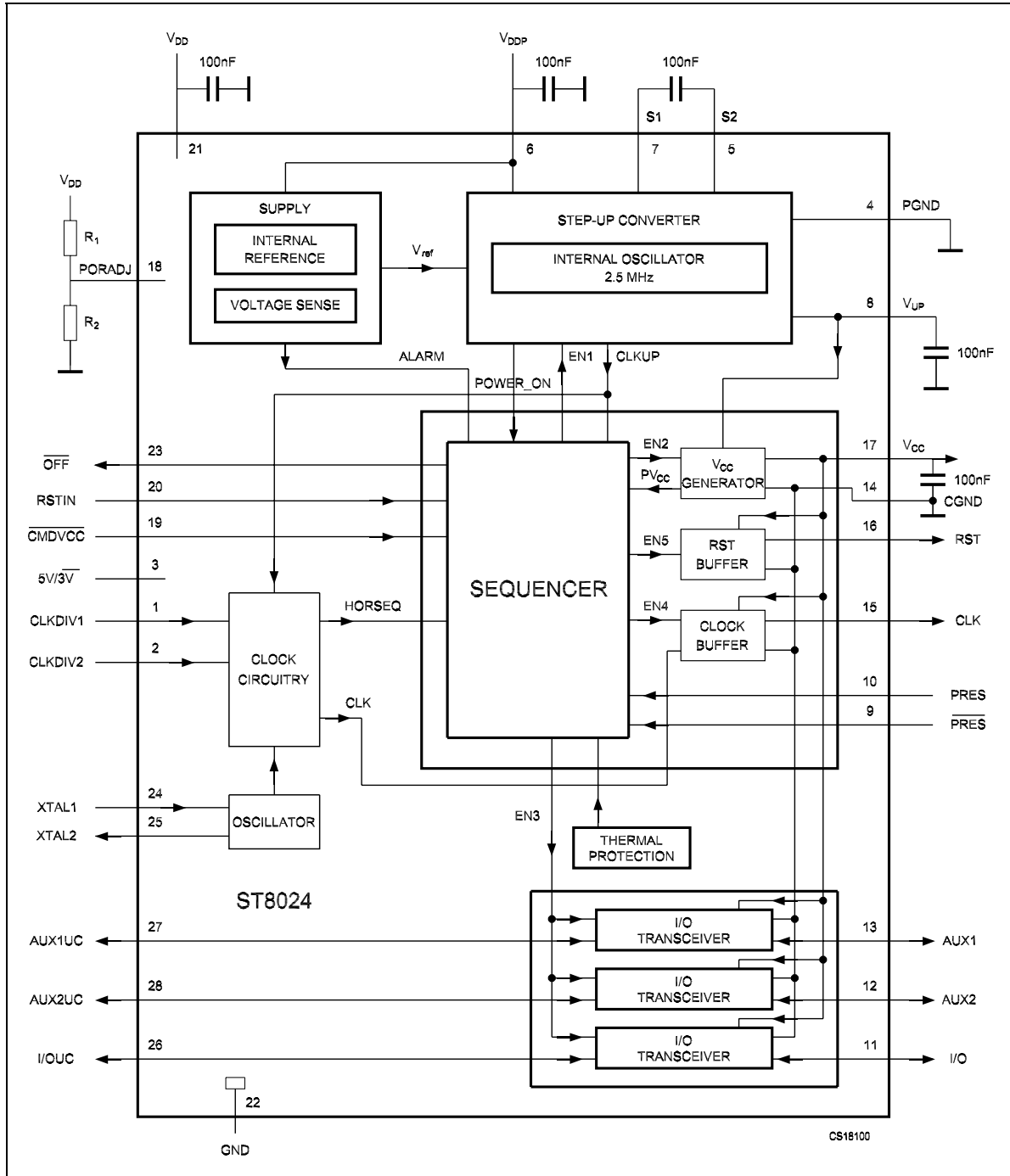

## 2 Pin configuration

Figure 2. Pin connections

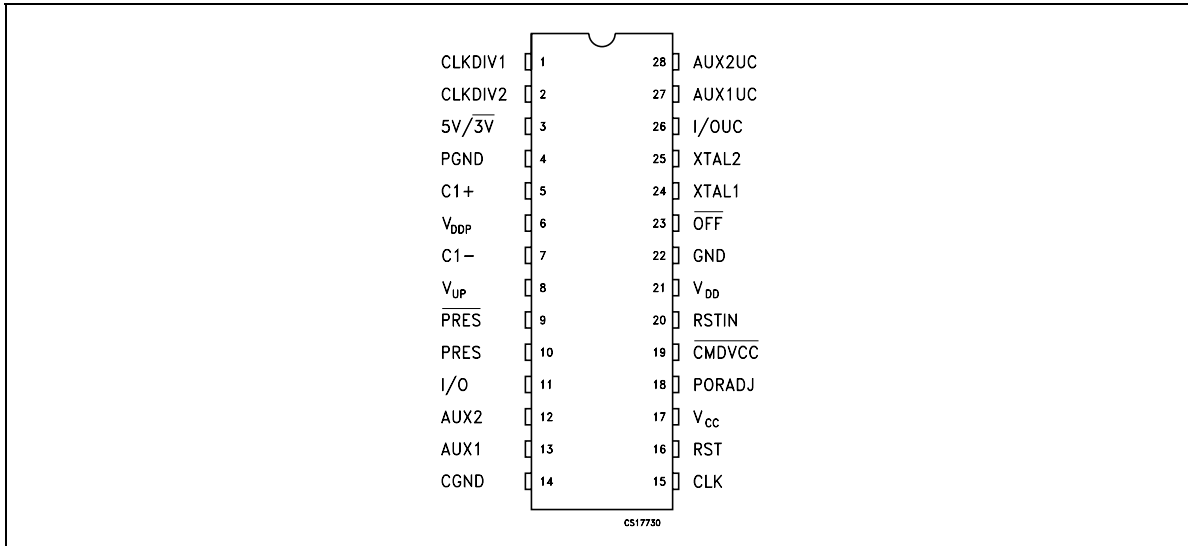

Table 2. Pin description

Pin n°	Symbol	Name and function
1	CLKDIV1	Control of CLK frequency
2	CLKDIV2	Control of CLK frequency
3	5V/ $\overline{3V}$	V <sub>CC</sub> selection pin
4	PGND	Power ground for step-up converter
5	C1+	External cap. for step-up converter
6	V <sub>DDP</sub>	Power supply for step-up converter
7	C1-	External cap. step-up converter
8	V <sub>UP</sub>	Output of step-up converter
9	$\overline{\text{PRES}}$	Card presence input (active low)
10	PRES	Card presence input (active high)
11	I/O	Data line to and from card (C7) (internal 11 kΩ pull-up resistor connected to V <sub>CC</sub> )
12	AUX2	Auxiliary line to and from card (C8) (internal 11 kΩ pull-up resistor connected to V <sub>CC</sub> )
13	AUX1	Auxiliary line to and from card (C4) (internal 11 kΩ pull-up resistor connected to V <sub>CC</sub> )
14	CGND	Ground for card signal (C5)
15	CLK	Clock to card (C3)
16	RST	Card reset (C2)
17	V <sub>CC</sub>	Supply voltage for the card (C1)
18	V <sub>THSEL</sub>	Deactivation threshold selector pin (under voltage lock-out)

Table 2. Pin description (continued)

Pin n°	Symbol	Name and function
19	$\overline{\text{CMDVCC}}$	Start activation sequence input (active low)
20	RSTIN	Card reset input from MCU
21	$V_{\text{DD}}$	Supply voltage
22	GND	Ground
23	$\overline{\text{OFF}}$	Interrupt to MCU (active low)
24	XTAL1	Crystal or external clock input
25	XTAL2	Crystal connection (leave this pin open if external clock is used)
26	I/OUC	MCU data I/O line (internal 11 k $\Omega$ pull-up resistor connected to $V_{\text{DD}}$ )
27	AUX1UC	Non-inverting receiver input (internal 11 k $\Omega$ pull-up resistor connected to $V_{\text{DD}}$ )
28	AUX2UC	Non-inverting receiver input (internal 11 k $\Omega$ pull-up resistor connected to $V_{\text{DD}}$ )

### 3 Maximum ratings

**Table 3. Absolute maximum ratings**

Symbol	Parameter	Min.	Max.	Unit
$V_{DD}, V_{DDP}$	Supply voltage	-0.3	7	V
$V_{n1}$	Voltage on pins XTAL1, XTAL2, $5V/\overline{3V}$ , RSTIN, AUX2UC, AUX1UC, I/OUC, CLKDIV1, CLKDIV2, PORADJ, $\overline{CMDVCC}$ , $\overline{PRES}$ , PRES and $\overline{OFF}$	-0.3	$V_{DD} + 0.3$	V
$V_{n2}$	Voltage on card contact pins I/O, RST, AUX1, AUX2 and CLK	-0.3	$V_{CC} + 0.3$	V
$V_{n3}$	Voltage on pins $V_{UP}$ S1 and S2		7	V
ESD1	MIL-STD-883 class 3 on card contact pins, $\overline{PRES}$ and PRES <sup>(1)</sup> <sub>(2)</sub>	-6	6	kV
ESD2	MIL-STD-883 class 2 on microcontroller contact pins and RSTIN <sup>(1)</sup> <sub>(2)</sub>	-2	2	kV
$T_{J(MAX)}$	Maximum operating junction temperature		150	°C
$T_{STG}$	Storage temperature range	-40	150	°C

1. All card contacts are protected against any short with any other card contact
2. Method 3015 (HBM, 1500  $\Omega$ , 100 pF) 3 positive pulses and 3 negative pulses on each pin referenced to ground.

*Note:* Absolute maximum ratings are those values beyond which damage to the device may occur. Functional operation under these conditions is not implied.

**Table 4. Thermal data**

Symbol	Parameter	Condition	SO-28	TSSOP28	Unit
$R_{thJA}$	Thermal resistance junction-ambient temperature	Multilayer test board (Jedec standard)	56	50	°K/W

**Table 5. Recommended operating conditions**

Symbol	Parameter	Test conditions	Min.	Typ.	Max.	Unit
$T_A$	Temperature range		-25		85	°C



## 4 Electrical characteristics

$V_{DD} = 3.3\text{ V}$ ,  $V_{DDP} = 5\text{ V}$ ,  $f_{XTAL} = 10\text{ MHz}$ , unless otherwise noted. Typical values are to  $T_A = 25\text{ }^\circ\text{C}$ .

**Table 6. Electrical characteristics over recommended operating condition**

Symbol	Parameter	Test conditions	Min.	Typ.	Max.	Unit
$V_{DD}$	Supply voltage		2.7		6.5	V
$V_{DDP}$	Supply voltage for the voltage doubler	$V_{CC} = 5\text{V}$ ; $ I_{CC}  < 80\text{ mA}$	4.0	5	6.5	V
		$V_{CC} = 5\text{V}$ ; $ I_{CC}  < 20\text{ mA}$	3.0		6.5	
$I_{DD}$	Supply current	Card Inactive			1.2	mA
		Card Active; $f_{CLK} = f_{XTAL}$ ; $C_L = 30\text{pF}$			1.5	
$I_{DDP}$	DC-DC converter supply current	Inactive mode			0.1	mA
		Active mode; $f_{CLK} = f_{XTAL}$ ; $C_L = 30\text{pF}$ ; $ I_{CC}  = 0$			10	
		$V_{CC} = 5\text{V}$ ; $ I_{CC}  = 80\text{ mA}$			200	
		$V_{CC} = 3\text{V}$ ; $ I_{CC}  = 65\text{ mA}$			100	
$V_{th2}$	Falling threshold voltage on $V_{DD}$	no external resistors at pin PORADJ; $V_{DD}$ level falling	2.35	2.45	2.55	V
$V_{HYS2}$	Hysteresis of threshold voltage $V_{th2}$	no external resistors at pin PORADJ	50	100	150	mV
$V_{th(ext)rise}$	External rising threshold voltage on $V_{DD}$	external resistor bridge at pin PORADJ; $V_{DD}$ level rising	1.25	1.28	1.31	V
$V_{th(ext)fall}$	External falling threshold voltage on $V_{DD}$	external resistor bridge at pin PORADJ; $V_{DD}$ level falling	1.19	1.22	1.25	V
$V_{HYS(ext)}$	Hysteresis of threshold voltage $V_{th(ext)}$	external resistor bridge at pin PORADJ	30	60	90	mV
$\Delta V_{HYS(ext)}$	Hysteresis of threshold voltage $V_{th(ext)}$ variation with temperature	external resistor bridge at pin PORADJ			0.25	mV/K
$t_W$	Width of internal Power-On reset pulse	no external resistor at pin PORADJ	4	8	12	ms
		external resistor bridge at pin PORADJ	8	16	24	
$I_L$	Leakage current on pin PORADJ	$V_{PORADJ} < 0.5\text{ V}$	-0.1	4	10	$\mu\text{A}$
		$V_{PORADJ} > 1.0\text{ V}$	-1		1	
$P_{TOT}$	Total power dissipation	Continuous operation; $T_a = -25\text{ to }85\text{ }^\circ\text{C}$			0.56	W

$V_{DD} = 3.3\text{ V}$ ,  $V_{DDP} = 5\text{ V}$ ,  $f_{XTAL} = 10\text{ MHz}$ , unless otherwise noted. Typical values are to  $T_A = 25\text{ }^\circ\text{C}$ .

**Table 7. Step-up converter**

Symbol	Parameter	Test conditions	Min.	Typ.	Max.	Unit
$f_{CLK}$	Clock frequency	Card active	2.2		3.2	MHz
$V_{th(vd-vf)}$	Threshold voltage for step-up converter to change to voltage follower	5 V card	5.2	5.8	6.2	V
		3 V card	3.8	4.1	4.4	
$V_{UP(av)}$	Output voltage on pin $V_{UP}$ (average value)	$V_{CC} = 5\text{ V}$	5.2	5.7	6.2	V
		$V_{CC} = 3\text{ V}$ ; $V_{DDP} = 3.3\text{ V}$	3.5	3.9	4.3	

$V_{DD} = 3.3\text{ V}$ ,  $V_{DDP} = 5\text{ V}$ ,  $f_{XTAL} = 10\text{ MHz}$ , unless otherwise noted. Typical values are to  $T_A = 25\text{ }^\circ\text{C}$  (*Note 1*).

**Table 8. Card supply voltage characteristics**

Symbol	Parameter	Test conditions	Min.	Typ.	Max.	Unit	
$C_{VCC}$	External capacitance on pin $V_{CC}$	<i>Note 2</i> and <i>Note 3</i>	80		220	nF	
$V_{CC}$	Card supply voltage (including ripple voltage)	Card Inactive; $ I_{CC}  = 0\text{ mA}$	5 and 3V card	-0.1	0	0.1	V
		Card Inactive; $ I_{CC}  = 1\text{ mA}$	5 and 3V card	-0.1	0	0.3	
		Card Active; $ I_{CC}  < 80\text{ mA}$	5 V card	4.75	5	5.25	
		Card Active; $ I_{CC}  < 65\text{ mA}$	3 V card	2.85	3	3.15	
		Card Active; single current pulse $I_P = -100\text{ mA}$ ; $t_p = 2\text{ }\mu\text{s}$	5 V card	4.65	5	5.25	
		Card Active; single current pulse $I_P = -100\text{ mA}$ ; $t_p = 2\text{ }\mu\text{s}$	3 V card	2.76	3	3.20	
		Card active; current pulses, $Q_P = 40\text{ nAs}$	5 V card	4.65	5	5.25	
			3 V card	2.76	3	3.20	
$V_{CC}$ (RIPPLE) (P-P)	Ripple voltage on $V_{CC}$ (Peak to Peak value)	$f_{RIPPLE} = 20\text{ kHz to }200\text{ MHz}$			350	mV	
$ I_{CC} $	Card supply current	$V_{CC} = 0\text{ to }5\text{ V}$			80	mA	
		$V_{CC} = 0\text{ to }3\text{ V}$			65		
		$V_{CC}$ short circuit to GND		90	120		
$S_R$	Slew rate	Slew up or down	0.08	0.15	0.22	V/ $\mu\text{s}$	

$V_{DD} = 3.3\text{ V}$ ,  $V_{DDP} = 5\text{ V}$ ,  $f_{XTAL} = 10\text{ MHz}$ , unless otherwise noted. Typical values are to  $T_A = 25\text{ }^\circ\text{C}$ .

**Table 9. Crystal connection (pins XTAL1 and XTAL2)**

Symbol	Parameter	Test conditions	Min.	Typ.	Max.	Unit
$C_{XTAL1,2}$	External capacitance on pins XTAL1, XTAL2	Depends on type of crystal or resonator used			15	pF
$f_{XTAL}$	Crystal frequency		2		26	MHz
$f_{XTAL1}$	Frequency applied on pin XTAL1		0		26	MHz
$V_{IH}$	High level input voltage on pin XTAL1		$0.7 V_{DD}$		$V_{DD}+0.3$	V
$V_{IL}$	Low level input voltage on pin XTAL1		-0.3		$+0.3V_{DD}$	V

$V_{DD} = 3.3\text{ V}$ ,  $V_{DDP} = 5\text{ V}$ ,  $f_{XTAL} = 10\text{ MHz}$ , unless otherwise noted. Typical values are to  $T_A = 25\text{ }^\circ\text{C}$ .

**Table 10. Data lines (pins I/O, I/OUC, AUX1, AUX2, AUX1UC AND AUX2UC)**

Symbol	Parameter	Test conditions	Min.	Typ.	Max.	Unit
$t_{D(I/O-I/OUC)}$ , $t_{D(I/OUC-I/O)}$	I/O to I/OUC, I/OUC to I/O falling edge delay				200	ns
$t_{pu}$	Active pull-up pulse width				100	ns
$f_{I/O(MAX)}$	Maximum frequency on data lines				1	MHz
$C_1$	Input capacitance on data lines				10	pF

$V_{DD} = 3.3\text{ V}$ ,  $V_{DDP} = 5\text{ V}$ ,  $f_{XTAL} = 10\text{ MHz}$ , unless otherwise noted. Typical values are to  $T_A = 25\text{ }^\circ\text{C}$ .

**Table 11. Data lines to card reader (pins I/O, AUX1 AND AUX2 with integrated 11 k $\Omega$  pull-up resistor to  $V_{CC}$ )**

Symbol	Parameter	Test conditions	Min.	Typ.	Max.	Unit	
$V_{O(inactive)}$	Output voltage	Inactive mode	NO LOAD	0		0.1	V
			$I_{O(inactive)}=1\text{ mA}$			0.3	
$I_{O(inactive)}$	Output current	Inactive mode; pin grounded			-1	mA	
$V_{OH}$	High level output voltage	No DC Load	$0.9 V_{CC}$		$V_{CC}+0.1$	V	
		5 and 3 V cards; $I_{OH} < -40\text{ }\mu\text{A}$	$0.75 V_{CC}$		$V_{CC}+0.1$		
		$ I_{OH}  \geq 10\text{ mA}$	0		0.4		
$V_{OL}$	Low level output voltage	$I_{OL} = 1\text{ mA}$	0		0.2	V	
		$I_{OL} \geq 15\text{ mA}$	$V_{CC}-0.4$		$V_{CC}$		
$V_{IH}$	High level input voltage		1.5		$V_{CC}+0.3$	V	
$V_{IL}$	Low level input voltage		0.3		0.8	V	
$ I_{LIH} $	High level input leakage current	$V_{IH} = V_{CC}$			10	$\mu\text{A}$	
$ I_{LIL} $	Low level input current	$V_{IL} = 0\text{ V}$			600	$\mu\text{A}$	

**Table 11. Data lines to card reader (pins I/O, AUX1 AND AUX2 with integrated 11 kΩ pull-up resistor to V<sub>CC</sub>)**

Symbol	Parameter	Test conditions	Min.	Typ.	Max.	Unit
R <sub>PU</sub>	Integrated pull-up resistor	Pull-up resistor to V <sub>CC</sub>	9	11	13	kΩ
t <sub>T(DI)</sub>	Data input transition time	V <sub>IL</sub> max to V <sub>IH</sub> min.			1.2	μs
t <sub>T(DO)</sub>	Data output transition time	V <sub>O</sub> = 0 to V <sub>CC</sub> ; C <sub>L</sub> ≤ 80 pF; 10% to 90%			0.1	μs
I <sub>PU</sub>	Current when pull-up active	V <sub>OH</sub> = 0.9V <sub>CC</sub> ; C <sub>L</sub> = 80 pF	-1			mA

V<sub>DD</sub> = 3.3 V, V<sub>DDP</sub> = 5 V, f<sub>X<sub>TAL</sub></sub> = 10 MHz, unless otherwise noted. Typical values are to T<sub>A</sub> = 25 °C.

**Table 12. Data lines to microcontroller (pins I/OUC, AUX1UC AND AUX2UC with integrated 11 kΩ pull-up resistor to V<sub>DD</sub>)**

Symbol	Parameter	Test conditions	Min.	Typ.	Max.	Unit
V <sub>OH</sub>	High level output voltage	5 and 3 V card; I <sub>OH</sub> < - 40μA	0.75 V <sub>DD</sub>		V <sub>DD</sub> +0.1	V
		No DC Load	0.9 V <sub>DD</sub>		V <sub>DD</sub> +0.1	
V <sub>OL</sub>	Low level output voltage	I <sub>OL</sub> = 1 mA	0		0.3	V
V <sub>IH</sub>	High level input voltage		0.7 V <sub>DD</sub>		V <sub>DD</sub> +0.3	V
V <sub>IL</sub>	Low level input voltage		-0.3		0.3 V <sub>DD</sub>	V
I <sub>L IH</sub>	High level input leakage current	V <sub>IH</sub> = V <sub>DD</sub>			10	μA
I <sub>L</sub>	Low level input current	V <sub>IL</sub> = 0 V			600	μA
R <sub>PU</sub>	Internal pull-up resistance to V <sub>DD</sub>	Pull-up resistor to V <sub>DD</sub>	9	11	13	kΩ
t <sub>T(DI)</sub>	Data input transition time	V <sub>IL(max)</sub> to V <sub>IH(min)</sub>			1.2	μs
t <sub>T(DO)</sub>	Data output transition time	V <sub>O</sub> = 0 to V <sub>DD</sub> ; C <sub>L</sub> < 30 pF; 10% to 90%			0.1	μs
I <sub>PU</sub>	Current when pull-up active	V <sub>OH</sub> = 0.9V <sub>DD</sub> ; C <sub>L</sub> = 30 pF	-1			mA

V<sub>DD</sub> = 3.3 V, V<sub>DDP</sub> = 5 V, f<sub>X<sub>TAL</sub></sub> = 10 MHz, unless otherwise noted. Typical values are to T<sub>A</sub> = 25 °C.

**Table 13. Internal oscillator**

Symbol	Parameter	Test conditions	Min.	Typ.	Max.	Unit
f <sub>OSC(INT)</sub>	Frequency of internal oscillator	Inactive mode	55	140	200	kHz
		Active mode	2.2	2.7	3.2	MHz

$V_{DD} = 3.3\text{ V}$ ,  $V_{DDP} = 5\text{ V}$ ,  $f_{XTAL} = 10\text{ MHz}$ , unless otherwise noted. Typical values are to  $T_A = 25\text{ }^\circ\text{C}$ .

**Table 14. Reset output to card reader (pin RST)**

Symbol	Parameter	Test conditions	Min.	Typ.	Max.	Unit
$V_{O(\text{inactive})}$	Output voltage in inactive mode	$I_{O(\text{inactive})} = 1\text{ mA}$	0		0.3	V
		No Load	0		0.1	
$I_{O(\text{inactive})}$	Output current	Inactive mode; pin grounded	0		-1	mA
$t_{D(\text{RSTIN-RST})}$	RSTN to RST Delay	RST Enable			2	$\mu\text{s}$
$V_{OL}$	Low level output voltage	$I_{OL} = 200\text{ }\mu\text{A}$	0		0.2	V
		$I_{OL} = 20\text{ mA}$ (current limit)	$V_{CC}-0.4$		$V_{CC}$	
$V_{OH}$	High level output voltage	$I_{OH} = -200\text{ }\mu\text{A}$	$0.9V_{CC}$		$V_{CC}$	V
		$I_{OH} = -20\text{ mA}$ (current limit)	0		0.4	
$t_R, t_F$	Rise and fall time	$C_L = 100\text{ pF}$ ; $V_{CC} = 5\text{ or }3\text{ V}$			0.1	$\mu\text{s}$

$V_{DD} = 3.3\text{ V}$ ,  $V_{DDP} = 5\text{ V}$ ,  $f_{XTAL} = 10\text{ MHz}$ , unless otherwise noted. Typical values are to  $T_A = 25\text{ }^\circ\text{C}$ .

**Table 15. Clock output to card reader (pin CLK)**

Symbol	Parameter	Test conditions	Min.	Typ.	Max.	Unit
$V_{O(\text{inactive})}$	Output voltage in inactive mode	$I_{O(\text{inactive})} = 1\text{ mA}$	0		0.3	V
		No Load	0		0.1	
$I_{O(\text{inactive})}$	Output current	CLK Inactive mode; pin grounded	0		-1	mA
$V_{OL}$	Low level output voltage	$I_{OL} = 200\text{ }\mu\text{A}$	0		0.3	V
		$I_{OL} = 70\text{ mA}$ (current limit)	$V_{CC}-0.4$		$V_{CC}$	
$V_{OH}$	High level output voltage	$I_{OH} = -200\text{ }\mu\text{A}$	$0.9V_{CC}$		$V_{CC}$	V
		$I_{OH} = -70\text{ mA}$ (current limit)	0		0.4	
$t_R, t_F$	Rise and fall time	$C_L = 30\text{ pF}$ (Note 4)			16	ns
$\delta$	Duty factor (except for $f_{XTALS}$ )	$C_L = 30\text{ pF}$ (Note 4)	45		55	%
$S_R$	Slew rate	Slew up or down; $C_L = 30\text{ pF}$	0.2			V/ns

$V_{DD} = 3.3\text{ V}$ ,  $V_{DDP} = 5\text{ V}$ ,  $f_{XTAL} = 10\text{ MHz}$ , unless otherwise noted. Typical values are to  $T_A = 25\text{ °C}$  (Note 5)

**Table 16. Control inputs (pins CLKDIV1, CLKDIV2,  $\overline{\text{CMDVCC}}$ , RSTIN and  $5\text{ V} / 3\text{ V}$ )**

Symbol	Parameter	Test conditions	Min.	Typ.	Max.	Unit
$V_{IL}$	Input voltage low		-0.3		$0.3V_{DD}$	V
$V_{IH}$	Input voltage high		$0.7V_{DD}$		$V_{DD}$	V
$ I_{L IH} $	Input leakage current high	$V_{IH} = V_{DD}$			1	$\mu\text{A}$
$ I_{L L} $	Input leakage current low	$V_{IL} = 0$			1	$\mu\text{A}$

$V_{DD} = 3.3\text{ V}$ ,  $V_{DDP} = 5\text{ V}$ ,  $f_{XTAL} = 10\text{ MHz}$ , unless otherwise noted. Typical values are to  $T_A = 25\text{ °C}$  (Note 6)

**Table 17. Card presence inputs (pins PRES and  $\overline{\text{PRES}}$ )**

Symbol	Parameter	Test conditions	Min.	Typ.	Max.	Unit
$V_{IL}$	Input voltage low		-0.3		$0.3 V_{DD}$	V
$V_{IH}$	Input voltage high		$0.7 V_{DD}$		$V_{DD}+0.3$	V
$ I_{L IH} $	Input leakage current high	$V_{IH} = V_{DD}$			5	$\mu\text{A}$
$ I_{L L} $	Input leakage current low	$V_{IL} = 0$			5	$\mu\text{A}$

$V_{DD} = 3.3\text{ V}$ ,  $V_{DDP} = 5\text{ V}$ ,  $f_{XTAL} = 10\text{ MHz}$ , unless otherwise noted. Typical values are to  $T_A = 25\text{ °C}$

**Table 18. Interrupt output (pin  $\overline{\text{OFF}}$  NMOS drain with integrated  $20\text{ k}\Omega$  pull-up resistor to  $V_{DD}$ );**

Symbol	Parameter	Test conditions	Min.	Typ.	Max.	Unit
$V_{OL}$	Low level output voltage	$I_{OL} = 2\text{ mA}$	0		0.3	V
$V_{OH}$	High level output voltage	$I_{OH} = -15\text{ }\mu\text{A}$	$0.75 V_{DD}$			V
$R_{PU}$	Integrated pull-up resistor	$20\text{ k}\Omega$ Pull-up resistor to $V_{DD}$	16	20	24	$\text{k}\Omega$

$V_{DD} = 3.3\text{ V}$ ,  $V_{DDP} = 5\text{ V}$ ,  $f_{XTAL} = 10\text{ MHz}$ , unless otherwise noted. Typical values are to  $T_A = 25\text{ °C}$ .

**Table 19. Protection and limitation**

Symbol	Parameter	Test conditions	Min.	Typ.	Max.	Unit
$ I_{CC(SD)} $	Shutdown and limitation current pin $V_{CC}$		90		120	mA
$I_{I/O(lim)}$	limitation current pins I/O, AUX1 and AUX2		-15		15	mA
$I_{CLK(lim)}$	limitation current pin CLK		-70		70	mA
$I_{RST(lim)}$	limitation current pin RST		-20		20	mA
$T_{SD}$	Shut down temperature			150		$^{\circ}\text{C}$

$V_{DD} = 3.3\text{ V}$ ,  $V_{DDP} = 5\text{ V}$ ,  $f_{XTAL} = 10\text{ MHz}$ , unless otherwise noted. Typical values are to  $T_A = 25\text{ }^\circ\text{C}$ .

**Table 20. Timing**

Symbol	Parameter	Test conditions	Min.	Typ.	Max.	Unit
$t_{ACT}$	Activation time	(See <a href="#">Figure 5</a> )		180	220	$\mu\text{s}$
$t_{DE}$	Deactivation time	(See <a href="#">Figure 7</a> )	60	80	100	$\mu\text{s}$
$t_3$	Start of the windows for sending CLK to card	(See <a href="#">Figure 6</a> )			130	$\mu\text{s}$
$t_5$	End of the windows for sending CLK to card	(See <a href="#">Figure 6</a> )	140			$\mu\text{s}$
$t_{debounce}$	Debounce time pins PRES and $\overline{PRES}$	(See <a href="#">Figure 8</a> )	140			$\mu\text{s}$

- Note:**
- 1 All parameters remain within limits but are tested only statistically for the temperature range. When a parameter is specified as a function of  $V_{DD}$  or  $V_{CC}$  it means their actual value at the moment of measurement.
  - 2 To meet these specifications, pin  $V_{CC}$  should be decoupled to CGND using two ceramic multilayer capacitors of low ESR both with values of 100 nF and 100 nF (see [Figure 10](#)).
  - 3 Permitted capacitor values are 100 + 100 nF, or 220 nF.
  - 4 Transition time and duty factor definitions are shown in [Figure 3](#);  $\delta = t_1/(t_1 + t_2)$ .
  - 5 Pin  $\overline{CMDVCC}$  is active LOW; pin RSTIN is active HIGH; for CLKDIV1 and CLKDIV2 functions see [Table 20](#)
  - 6 Pin  $\overline{PRES}$  is active LOW; pin PRES is active HIGH see [Figure 8](#) and [Figure 9](#); PRES has an integrated 1.25  $\mu\text{A}$  current source to GND. (PRES to  $V_{DD}$ ); the card is considered present if at least one of the inputs PRES or  $\overline{PRES}$  is active.

**Figure 3. Definition of output and input transition times**

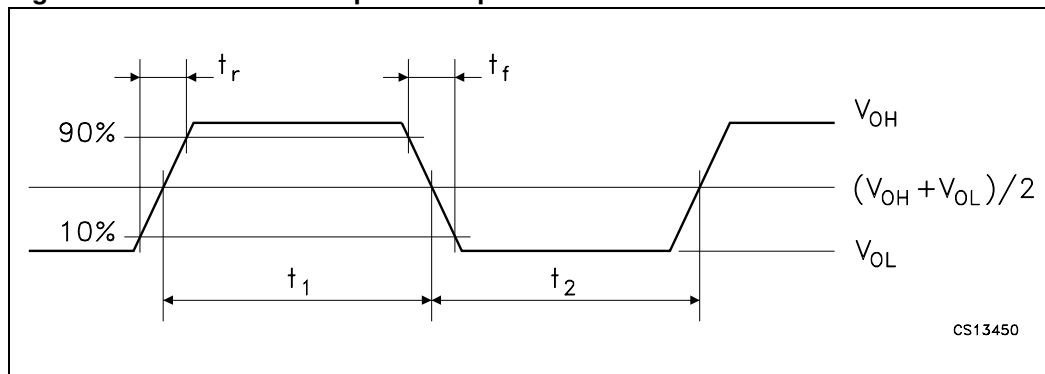

## 5 Functional description

Throughout this document it is assumed that the reader is familiar with ISO7816 terminology.

### 5.1 Power supply

The supply pins for the IC are  $V_{DD}$  and GND.  $V_{DD}$  should be in the range of 2.7 to 6.5 V. All signals interfacing with the system controller are referred to  $V_{DD}$ , therefore  $V_{DD}$  should also supply the system controller. All card reader contacts remain inactive during power-on or power-off.

The internal circuits are maintained in the reset state until  $V_{DD}$  reaches  $V_{th2} + V_{hys2}$  and for the duration of the internal power-on reset pulse,  $t_W$  (see [Figure 4](#)). When  $V_{DD}$  falls below  $V_{th2}$ , an automatic deactivation of the contacts is performed.

A DC-DC converter is incorporated to generate the 5 or 3 V card supply voltage ( $V_{CC}$ ). The DC-DC converter should be supplied separately by  $V_{DDP}$  and PGND. Due to the possibility of large transient currents, the two 100 nF capacitors of the DC-DC converter should be located as near as possible to the IC and have an ESR less than 100 m $\Omega$ .

The DC-DC converter functions as a voltage doubler or a voltage follower according to the respective values of  $V_{CC}$  and  $V_{DDP}$  (both have thresholds with a hysteresis of 100 mV).

The DC-DC converter function changes as follows:

$V_{CC} = 5$  V and  $V_{DDP} > 5.8$  V; voltage follower

$V_{CC} = 5$  V and  $V_{DDP} < 5.7$  V; voltage doubler

$V_{CC} = 3$  V and  $V_{DDP} > 4.1$  V; voltage follower

$V_{CC} = 3$  V and  $V_{DDP} < 4.0$  V; voltage doubler.

Supply voltages  $V_{DD}$  and  $V_{DDP}$  may be applied to the IC in any sequence.

After powering the device, OFF remains LOW until  $\overline{CMDVCC}$  is set HIGH.

During power off, OFF falls LOW when  $V_{DD}$  is below the falling threshold voltage.

### 5.2 Voltage supervisor

#### 5.2.1 Without external divider on pin PORADJ

The voltage supervisor surveys the  $V_{DD}$  supply. A defined reset pulse of approximately 8 ms ( $t_W$ ) is used internally to keep the IC inactive during power-on or power-off of the  $V_{DD}$  supply (see [Figure 4](#)).

As long as  $V_{DD}$  is less than  $V_{th2} + V_{hys2}$ , the IC remains inactive whatever the levels on the command lines. This state also lasts for the duration of  $t_W$  after  $V_{DD}$  has reached a level higher than  $V_{th2} + V_{hys2}$ . When  $V_{DD}$  falls below  $V_{th2}$ , a deactivation sequence of the contacts is performed.



Figure 4. Voltage supervisor

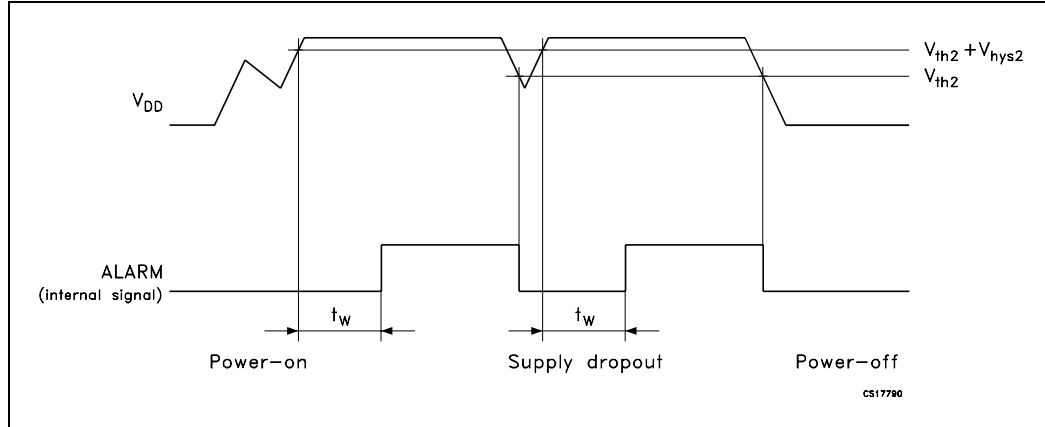

### 5.2.2 With an external divider on pin PORADJ

If an external resistor bridge is connected to pin PORADJ (R1 and R2 in [Figure 1](#)), then the following occurs:

- The internal threshold voltage  $V_{th2}$  is overridden by the external voltage and by the hysteresis, therefore:

$$V_{th2(ext)(rise)} = (1 + R1/R2) \times (V_{bridge} + V_{hys(ext)}/2)$$

$$V_{th2(ext)(fall)} = (1 + R1/R2) \times (V_{bridge} - V_{hys(ext)}/2)$$

where  $V_{bridge} = 1.25 \text{ V typ.}$  and  $V_{hys(ext)} = 60 \text{ mV typ.}$

- The reset pulse width  $t_w$  is doubled to approximately 16 ms.

Input PORADJ is biased internally with a pull-down current source of  $4 \mu\text{A}$  which is removed when the voltage on pin PORADJ exceeds 1 V.

This ensures that after detection of the external bridge by the IC during power-on, the input current on pin PORADJ does not cause inaccuracy of the bridge voltage.

The minimum threshold voltage should be higher than 2 V. The maximum threshold voltage may be up to  $V_{DD}$ .

### 5.2.3 Application examples

The voltage supervisor is used as power-on reset and as supply dropout detection during a card session. Supply dropout detection is to ensure that a proper deactivation sequence is followed before the voltage is too low. For the internal voltage supervisor to function, the system microcontroller should operate down to 2.35 V to ensure a proper deactivation sequence. If this is not possible, external resistor values can be chosen to overcome the problem.

## 5.3 Clock circuitry

The card clock signal (CLK) is derived from a clock signal input to pin XTAL1 or from a crystal operating at up to 26 MHz connected between pins XTAL1 and XTAL2.

The clock frequency can be  $f_{XTAL}$ ,  $1/2 \times f_{XTAL}$ ,  $1/4 \times f_{XTAL}$  or  $1/8 \times f_{XTAL}$ . Frequency selection is made via inputs CLKDIV1 and CLKDIV2 (see [Table 21](#)).

**Table 21. Clock frequency selection (1)**

CLKDIV1	CLKDIV2	$f_{\text{CLK}}$
0	0	$f_{\text{XTAL}}/8$
0	1	$f_{\text{XTAL}}/4$
1	1	$f_{\text{XTAL}}/2$
1	0	$f_{\text{XTAL}}$

1. The status of pins CLKDIV1 and CLKDIV2 must not be changed simultaneously; a delay of 10 ns minimum between changes is needed; the minimum duration of any state of CLK is eight periods of XTAL1.

The frequency change is synchronous, which means that during transition no pulse is shorter than 45 % of the smallest period, and that the first and last clock pulses about the instant of change have the correct width.

When changing the frequency dynamically, the change is effective for only eight periods of XTAL1 after the command. The duty factor of  $f_{\text{XTAL}}$  depends on the signal present at pin XTAL1. In order to reach a 45 to 55 % duty factor on pin CLK, the input signal on pin XTAL1 should have a duty factor of 48 to 52 % and transition times of less than 5 % of the input signal period.

If a crystal is used, the duty factor on pin CLK may be 45 to 55 % depending on the circuit layout and on the crystal characteristics and frequency. In other cases, the duty factor on pin CLK is guaranteed between 45 and 55 % of the clock period.

The crystal oscillator runs as soon as the IC is powered up. If the crystal oscillator is used, or if the clock pulse on pin XTAL1 is permanent, the clock pulse is applied to the card as shown in the activation sequences shown in [Figure 5](#) and [Figure 6](#)

If the signal applied to XTAL1 is controlled by the system microcontroller, the clock pulse will be applied to the card when it is sent by the system microcontroller (after completion of the activation sequence).

## 5.4 I/O transceivers

The three data lines I/O, AUX1 and AUX2 are identical. The idle state is realized by both I/O and I/OUC lines being pulled HIGH via a 11 k $\Omega$  resistor (I/O to  $V_{\text{CC}}$  and I/OUC to  $V_{\text{DD}}$ ). Pin I/O is referenced to  $V_{\text{CC}}$ , and pin I/OUC to  $V_{\text{DD}}$ , thus allowing operation when  $V_{\text{CC}}$  is not equal to  $V_{\text{DD}}$ . The first side of the transceiver to receive a falling edge becomes the master. An anti-latch circuit disables the detection of falling edges on the line of the other side, which then becomes a slave. After a time delay  $t_{d(\text{edge})}$ , an N transistor on the slave side is turned on, thus transmitting the logic 0 present on the master side. When the master side returns to logic 1, a P transistor on the slave side is turned on during the time delay  $t_{\text{pu}}$  and then both sides return to their idle states. This active pull-up feature ensures fast LOW-to-HIGH transitions; it is able to deliver more than 1 mA at an output voltage of up to 0.9  $V_{\text{CC}}$  into an 80 pF load. At the end of the active pull-up pulse, the output voltage depends only on the internal pull-up resistor and the load current. The current to and from the card I/O lines is limited internally to 15 mA and the maximum frequency on these lines is 1 MHz.

## 5.5 Inactive mode

After a power-on reset, the circuit enters the inactive mode. A minimum number of circuits are active while waiting for the microcontroller to start a session:

- All card contacts are inactive (approximately 200  $\Omega$  to GND)
- Pins I/OUC, AUX1UC and AUX2UC are in the high-impedance state (11 k $\Omega$  pull-up resistor to  $V_{DD}$ )
- Voltage generators are stopped
- XTAL oscillator is running
- Voltage supervisor is active
- The internal oscillator is running at its low frequency.

## 5.6 Activation sequence

After power-on and after the internal pulse width delay, the system microcontroller can check the presence of a card using the signals  $\overline{OFF}$  and  $\overline{CMDVCC}$  as shown in [Table 22](#).

If the card is in the reader (this is the case if  $\overline{PRES}$  or PRES is active), the system microcontroller can start a card session by pulling  $\overline{CMDVCC}$  LOW. The following sequence then occurs (see [Figure 6](#)):

1.  $\overline{CMDVCC}$  is pulled LOW and the internal oscillator changes to its high frequency ( $t_0$ ).
2. The voltage doubler is started (between  $t_0$  and  $t_1$ ).
3.  $V_{CC}$  rises from 0 to 5 V (or 3 V) with a controlled slope ( $t_2 = t_1 + 1.5 \times T$ ) where T is 64 times the period of the internal oscillator (approximately 25  $\mu$ s).
4. I/O, AUX1 and AUX2 are enabled ( $t_3 = t_1 + 4T$ ) (these were pulled LOW until this moment).
5. CLK is applied to the C3 contact of the card reader ( $t_4$ ).
6. RST is enabled ( $t_5 = t_1 + 7T$ ).

The clock may be applied to the card using the following sequence (see [Figure 5](#)):

1. Set RSTIN HIGH.
2. Set  $\overline{CMDVCC}$  LOW.
3. Reset RSTIN LOW between  $t_3$  and  $t_5$ ; CLK will start at this moment.
4. RST remains LOW until  $t_5$ , when RST is enabled to be the copy of RSTIN.
5. After  $t_5$ , RSTIN has no further affect on CLK; this allows a precise count of CLK pulses before toggling RST.

If the applied clock is not needed, then  $\overline{CMDVCC}$  may be set LOW with RSTIN LOW. In this case, CLK will start at  $t_3$  (minimum 200 ns after the transition on I/O), and after  $t_5$ , RSTIN may be set HIGH in order to obtain an Answer To Request (ATR) from the card.

Activation should not be performed with RSTIN held permanently HIGH

**Table 22. Card presence indicator**

$\overline{OFF}$	$\overline{CMDVCC}$	Indication
H	H	Card present
L	H	Card not present

Figure 5. Activation sequence using RSTIN and  $\overline{\text{CMDVCC}}$

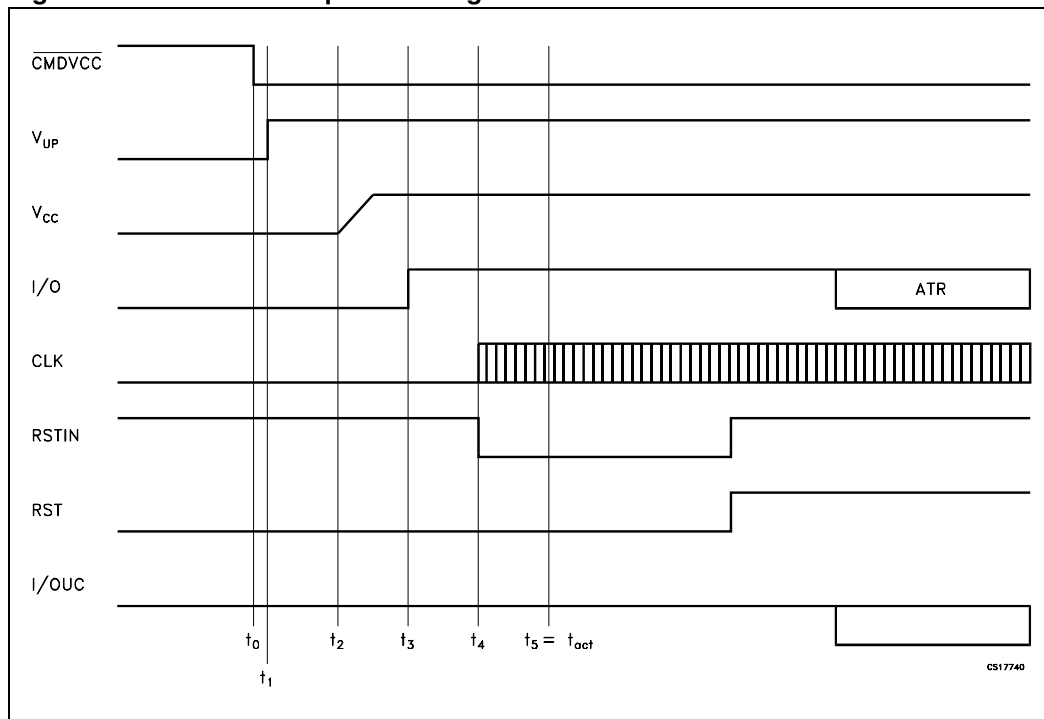
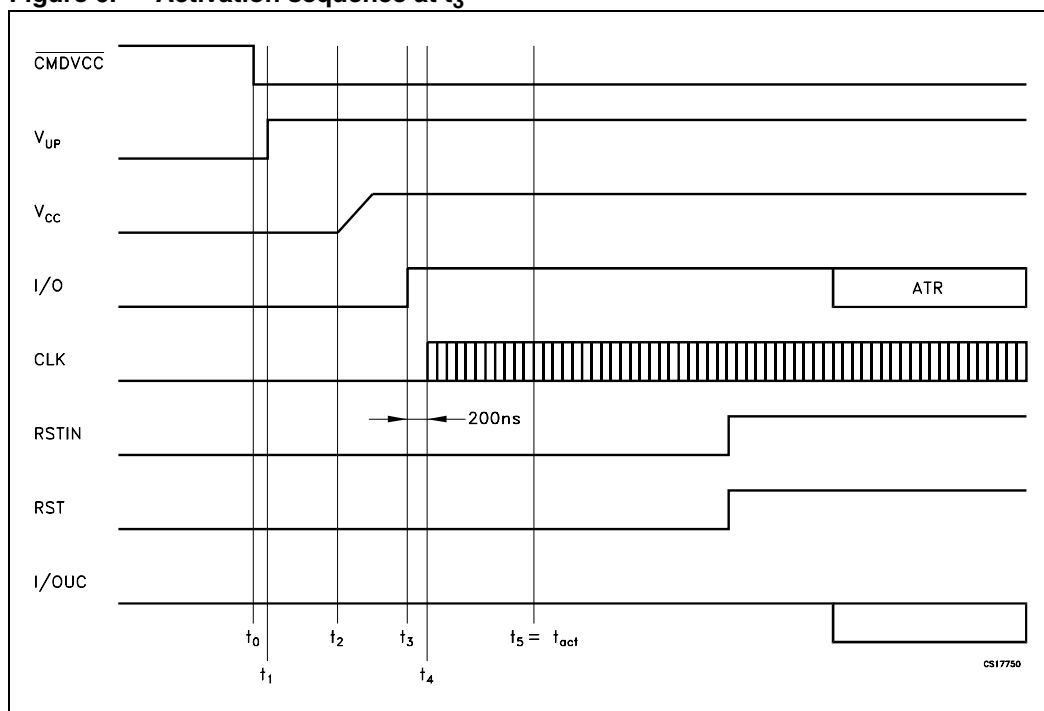

Figure 6. Activation sequence at  $t_3$



## 5.7 Active mode

When the activation sequence is completed, the ST8024 will be in its active mode. Data are exchanged between the card and the microcontroller via the I/O lines.

The ST8024 is designed for cards without  $V_{PP}$  (the voltage required to program or erase the internal non-volatile memory).

## 5.8 Deactivation sequence

When a session is completed, the microcontroller sets the  $\overline{\text{CMDVCC}}$  line HIGH. The circuit then executes an automatic deactivation sequence by counting the sequencer back and finishing in the inactive mode (see [Figure 7](#)):

1. RST goes LOW ( $t_{10}$ ).
2. CLK is held LOW ( $t_{12} = t_{10} + 0.5 \times T$ ) where T is 64 times the period of the internal oscillator (approximately 25  $\mu\text{s}$ ).
3. I/O, AUX1 and AUX2 are pulled LOW ( $t_{13} = t_{10} + T$ ).
4.  $V_{CC}$  starts to fall towards zero ( $t_{14} = t_{10} + 1.5 \times T$ ).
5. The deactivation sequence is complete at  $t_{de}$ , when  $V_{CC}$  reaches its inactive state.
6.  $V_{UP}$  falls to zero ( $t_{15} = t_{10} + 5T$ ) and all card contacts become low-impedance to GND; I/OUC, AUX1UC and AUX2UC remain at  $V_{DD}$  (pulled-up via a 11 k $\Omega$  resistor).
7. The internal oscillator returns to its lower frequency.

**Figure 7. Deactivation sequence**

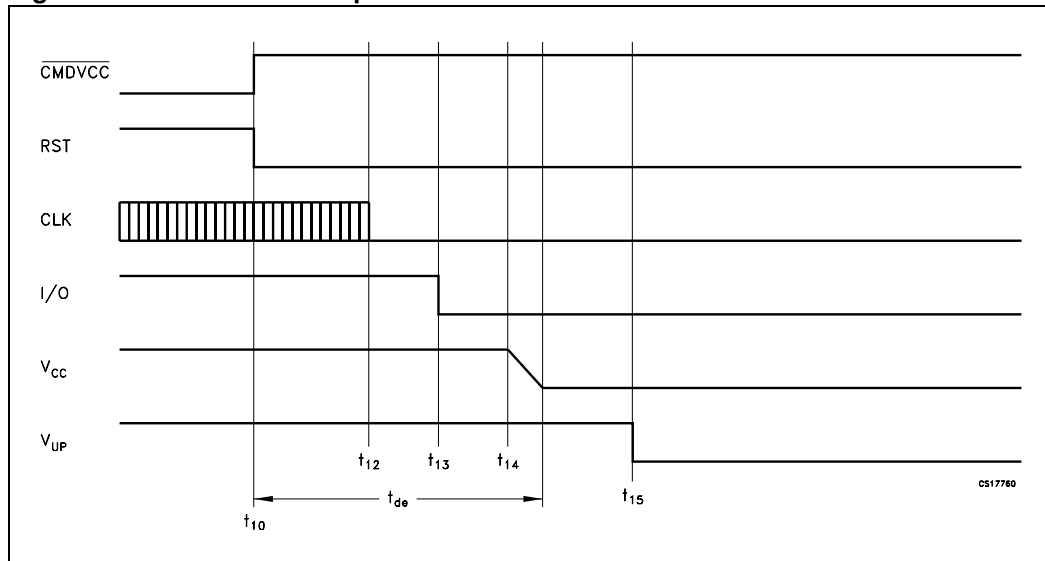

## 5.9 $V_{CC}$ generator

The  $V_{CC}$  generator has a capacity to supply up to 80 mA continuously at 5 V and 65 mA at 3 V. An internal overload detector operates at approximately 120 mA. Current samples to the

detector are internally filtered, allowing spurious current pulses up to 200 mA with a duration in the order of  $\mu\text{s}$  to be drawn by the card without causing deactivation. The average current must stay below the specified maximum current value. For reasons of  $V_{CC}$  voltage accuracy, a 100 nF capacitor with an ESR  $< 100 \text{ m}\Omega$  should be tied to CGND near to pin  $V_{CC}$ , and 100 nF capacitor with the same ESR should be tied to CGND near card reader contact C1.

## 5.10 Fault detection

The following fault conditions are monitored:

- Short-circuit or high current on  $V_{CC}$
- Removal of a card during a transaction
- $V_{DD}$  dropping
- DC-DC converter operating out of the specified values ( $V_{DDP}$  too low or current from  $V_{UP}$  too high)
- Overheating.
- There are two different cases (see [Figure 8](#)):
- $\overline{\text{CMDVCC}}$  HIGH outside a card session. Output  $\overline{\text{OFF}}$  is LOW if a card is not in the card reader, and HIGH if a card is in the reader. A voltage drop on the  $V_{DD}$  supply is detected by the supply supervisor, this generates an internal Power-on reset pulse but does not act upon  $\overline{\text{OFF}}$ . No short-circuit or overheating is detected because the card is not powered-up.
- $\overline{\text{CMDVCC}}$  LOW within a card session. Output  $\overline{\text{OFF}}$  goes LOW when a fault condition is detected. As soon as this occurs, an emergency deactivation is performed automatically (see [Figure 9](#)). When the system controller resets  $\overline{\text{CMDVCC}}$  to HIGH it may sense the  $\overline{\text{OFF}}$  level again after completing the deactivation sequence. This distinguishes between a hardware problem or a card extraction ( $\overline{\text{OFF}}$  goes HIGH again if a card is present).

Depending on the type of card-present switch within the connector (normally-closed or normally-open) and on the mechanical characteristics of the switch, bouncing may occur on the PRES signals at card insertion or withdrawal.

There is a debounce feature in the device with an 8 ms typical duration (see [Figure 8](#)). When a card is inserted, output  $\overline{\text{OFF}}$  goes HIGH only at the end of the debounce time.

When the card is extracted, an automatic deactivation sequence of the card is performed on the first true/false transition on PRES or PRES and output  $\overline{\text{OFF}}$  goes LOW.

**Figure 8. Behavior of  $\overline{\text{OFF}}$ ,  $\overline{\text{CMDVCC}}$ , PRES and  $V_{CC}$**

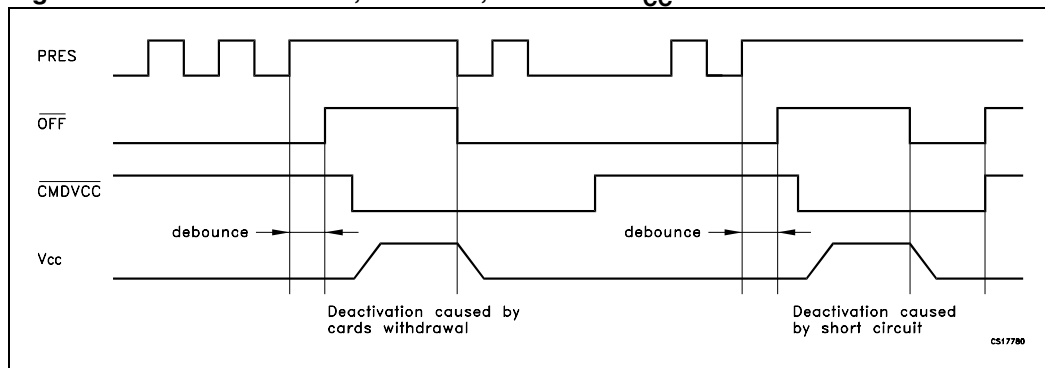
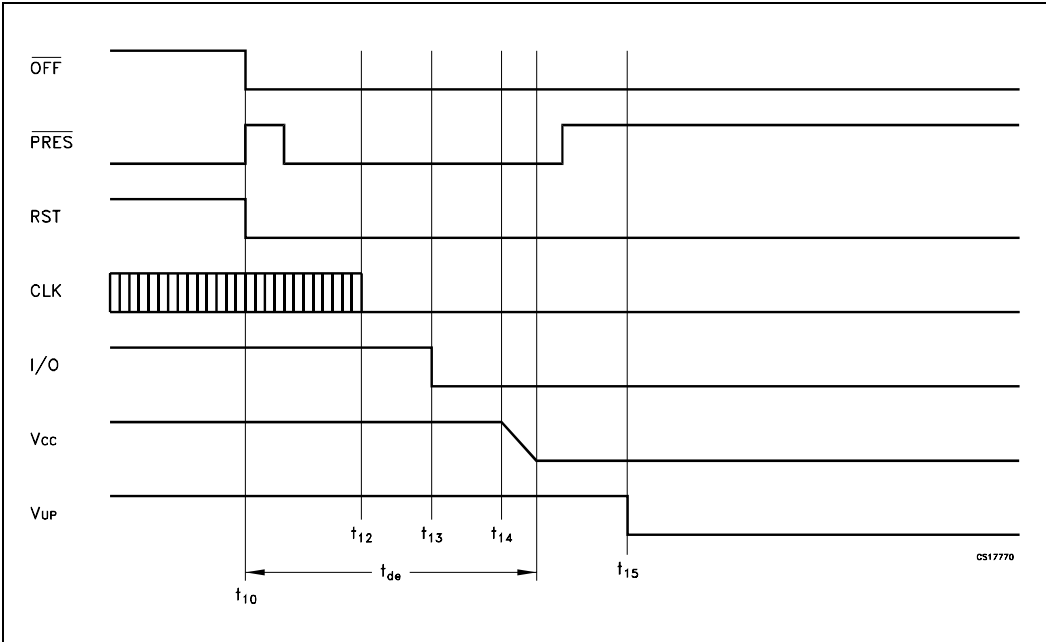
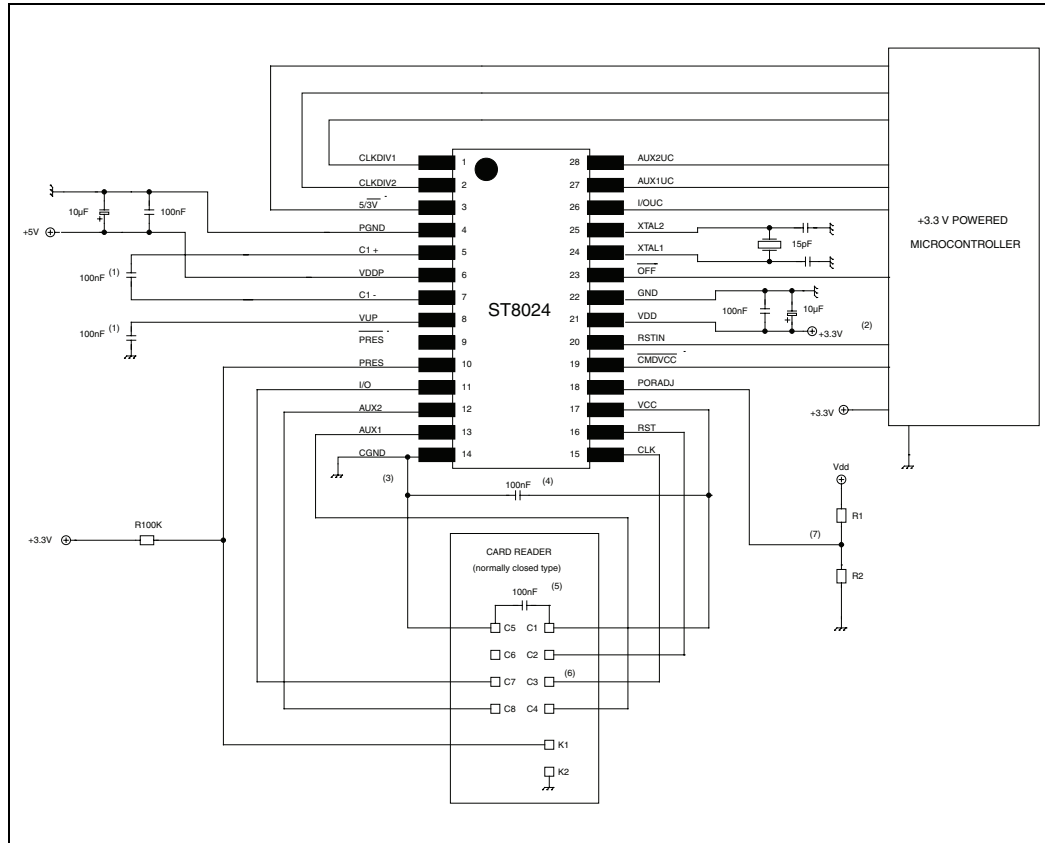

Figure 9. Emergency deactivation sequence (card extraction)



## 6 Application

Figure 10. Application diagram



- (1) These capacitors must be of the low ESR-type and be placed near the IC (within 100 mm).
- (2) ST8024 and the microcontroller must use the same  $V_{DD}$  supply.
- (3) Make short, straight connections between CGND, C5 and the ground connection to the capacitor.
- (4) Mount one low ESR-type 100 nF capacitor close to pin  $V_{CC}$ .
- (5) Mount one low ESR-type 100 nF capacitor close to C1 contact.
- (6) The connection to C3 should be routed as far from C2, C7, C4 and C8 and, if possible, surrounded by grounded tracks.
- (7) Optional resistor bridge for changing the threshold of  $V_{DD}$ . If this bridge is not required pin 18 should be connected to ground.



## 7 Package mechanical data

In order to meet environmental requirements, ST offers these devices in different grades of ECOPACK<sup>®</sup> packages, depending on their level of environmental compliance. ECOPACK<sup>®</sup> specifications, grade definitions and product status are available at: [www.st.com](http://www.st.com). ECOPACK is an ST trademark.

**SO-28 mechanical data**

Dim.	mm.			inch.		
	Min.	Typ.	Max.	Min.	Typ.	Max.
A			2.65			0.104
a1	0.1		0.3	0.004		0.012
b	0.35		0.49	0.014		0.019
b1	0.23		0.32	0.009		0.012
C		0.5			0.020	
c1	45° (typ.)					
D	17.70		18.10	0.697		0.713
E	10.00		10.65	0.393		0.419
e		1.27			0.050	
e3		16.51			0.650	
F	7.40		7.60	0.291		0.300
L	0.50		1.27	0.020		0.050
S	8° (max.)					

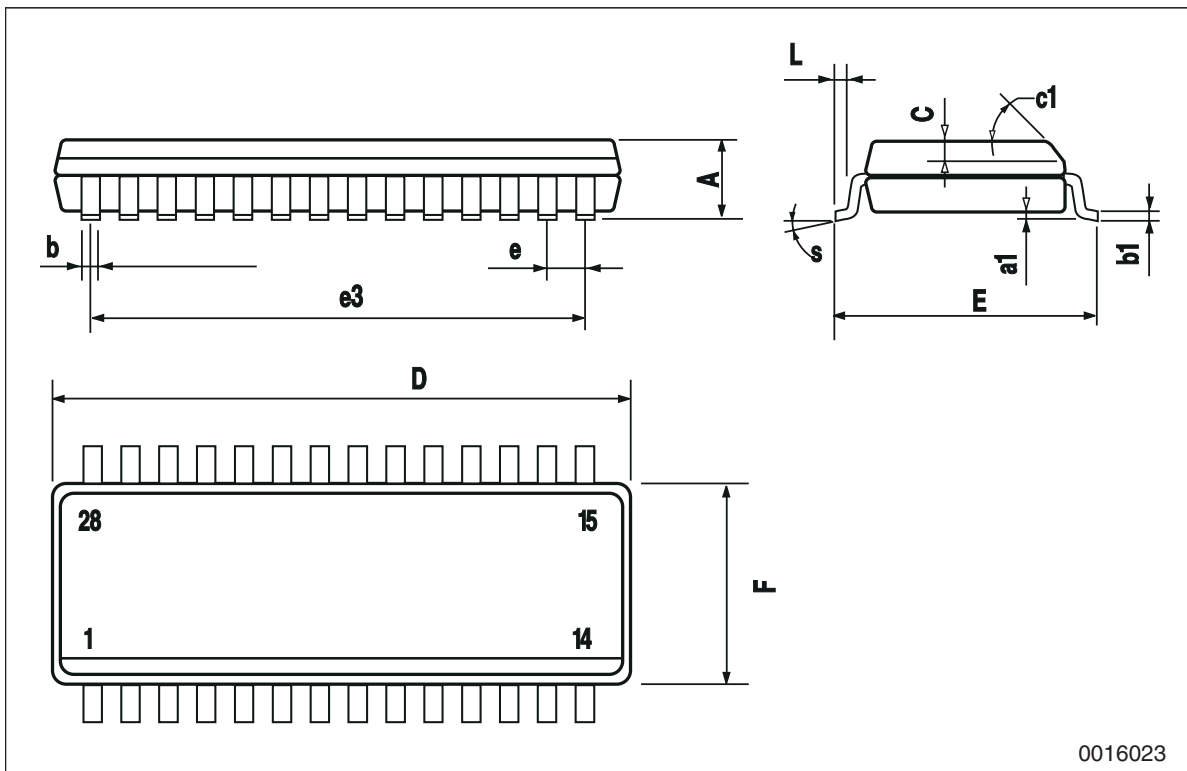

0016023

## TSSOP28 mechanical data

Dim.	mm.			inch.		
	Min.	Typ.	Max.	Min.	Typ.	Max.
A			1.2			0.047
A1	0.05		0.15	0.002	0.004	0.006
A2	0.8	1	1.05	0.031	0.039	0.041
b	0.19		0.30	0.007		0.012
c	0.09		0.20	0.004		0.0079
D	9.6	9.7	9.8	0.378	0.382	0.386
E	6.2	6.4	6.6	0.244	0.252	0.260
E1	4.3	4.4	4.48	0.169	0.173	0.176
e		0.65 BSC			0.0256 BSC	
K	0°		8°	0°		8°
L	0.45	0.60	0.75	0.018	0.024	0.030

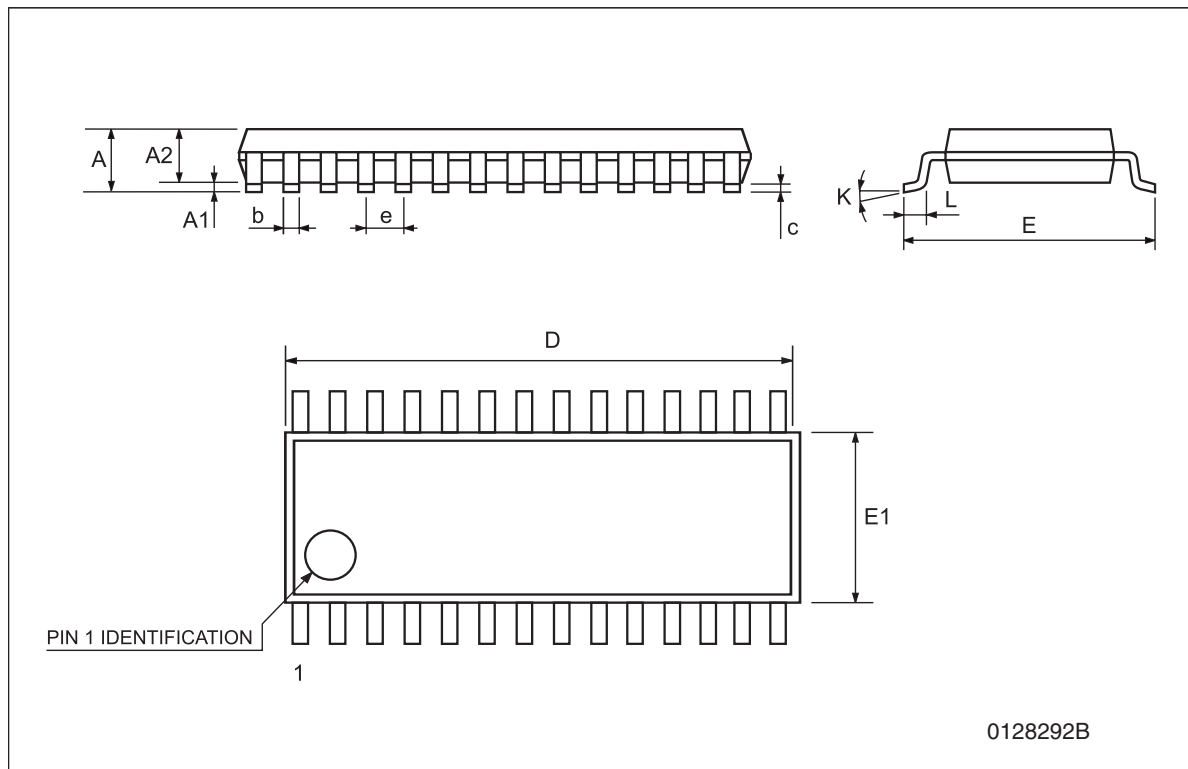

**Tape & reel SO-28 mechanical data**

Dim.	mm.			inch.		
	Min.	Typ.	Max.	Min.	Typ.	Max.
A			330			12.992
C	12.8		13.2	0.504		0.519
D	20.2			0.795		
N	60			2.362		
T			30.4			1.197
Ao	10.8		11.0	0.425		0.433
Bo	18.2		18.4	0.716		0.724
Ko	2.9		3.1	0.114		0.122
Po	3.9		4.1	0.153		0.161
P	11.9		12.1	0.468		0.476

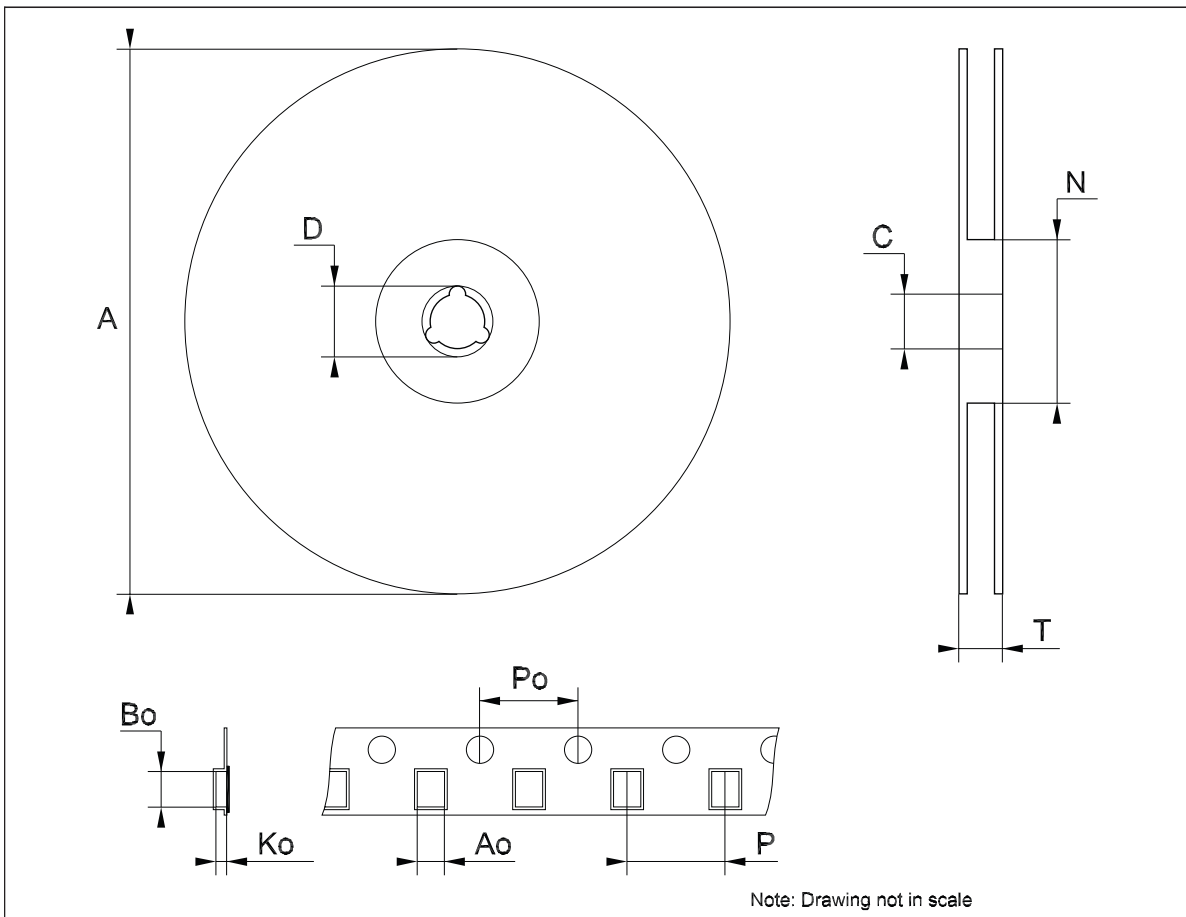

## Tape &amp; reel TSSOP28 mechanical data

Dim.	mm.			inch.		
	Min.	Typ.	Max.	Min.	Typ.	Max.
A			330			12.992
C	12.8		13.2	0.504		0.519
D	20.2			0.795		
N	60			2.362		
T			22.4			0.882
Ao	6.8		7	0.268		0.276
Bo	10.1		10.3	0.398		0.406
Ko	1.7		1.9	0.067		0.075
Po	3.9		4.1	0.153		0.161
P	11.9		12.1	0.468		0.476

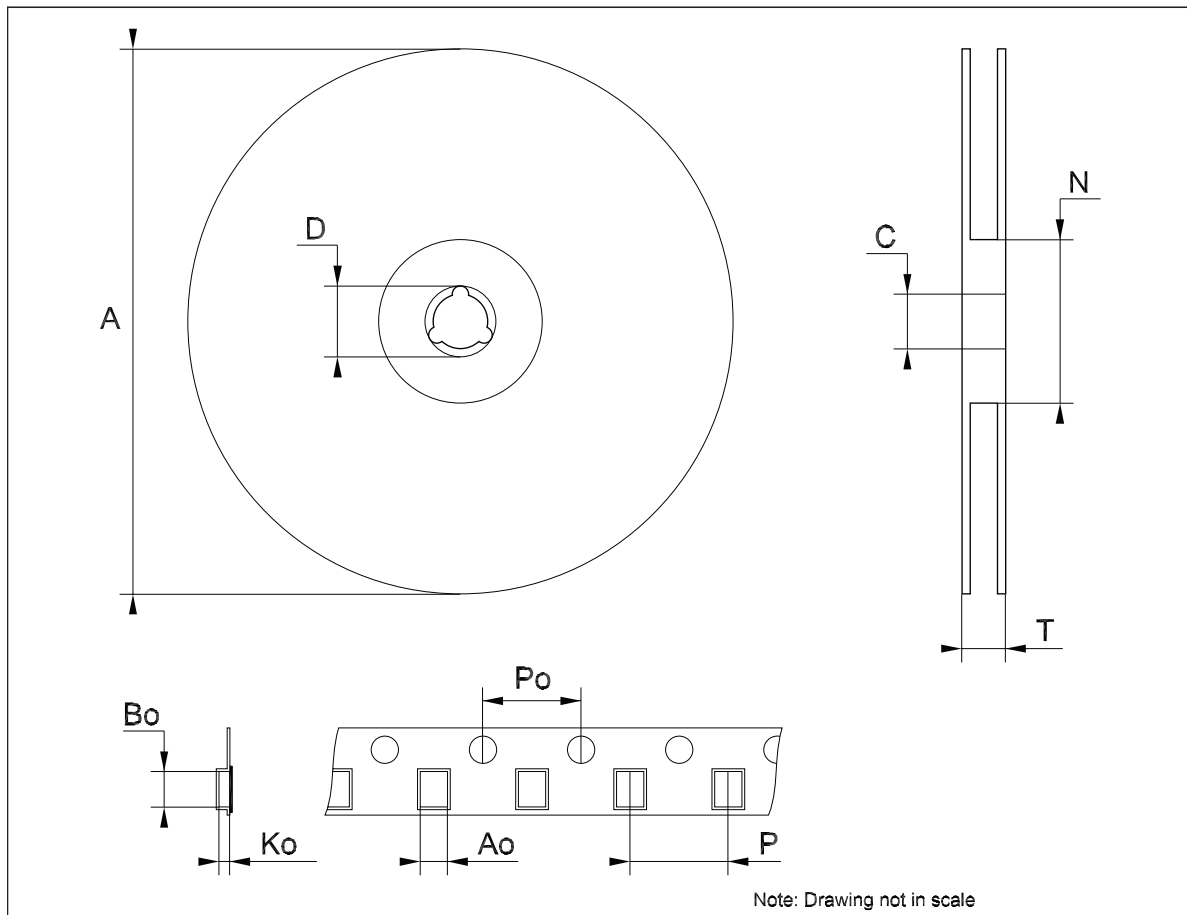

## 8 Revision history

**Table 23. Document revision history**

Date	Revision	Changes
18-Mar-2004	4	Pag. 10, fig. 4, RSTIN ==> CLK.
27-Jun-2006	5	Add package TSSOP28.
13-Dec-2006	6	Removed: the comment point 5 on page 22.
03-Jun-2008	7	Added: <a href="#">Table 1 on page 1</a> .
30-Mar-2009	8	Modified: <a href="#">Figure 10 on page 24</a> .

**Please Read Carefully:**

Information in this document is provided solely in connection with ST products. STMicroelectronics NV and its subsidiaries ("ST") reserve the right to make changes, corrections, modifications or improvements, to this document, and the products and services described herein at any time, without notice.

All ST products are sold pursuant to ST's terms and conditions of sale.

Purchasers are solely responsible for the choice, selection and use of the ST products and services described herein, and ST assumes no liability whatsoever relating to the choice, selection or use of the ST products and services described herein.

No license, express or implied, by estoppel or otherwise, to any intellectual property rights is granted under this document. If any part of this document refers to any third party products or services it shall not be deemed a license grant by ST for the use of such third party products or services, or any intellectual property contained therein or considered as a warranty covering the use in any manner whatsoever of such third party products or services or any intellectual property contained therein.

**UNLESS OTHERWISE SET FORTH IN ST'S TERMS AND CONDITIONS OF SALE ST DISCLAIMS ANY EXPRESS OR IMPLIED WARRANTY WITH RESPECT TO THE USE AND/OR SALE OF ST PRODUCTS INCLUDING WITHOUT LIMITATION IMPLIED WARRANTIES OF MERCHANTABILITY, FITNESS FOR A PARTICULAR PURPOSE (AND THEIR EQUIVALENTS UNDER THE LAWS OF ANY JURISDICTION), OR INFRINGEMENT OF ANY PATENT, COPYRIGHT OR OTHER INTELLECTUAL PROPERTY RIGHT.**

**UNLESS EXPRESSLY APPROVED IN WRITING BY AN AUTHORIZED ST REPRESENTATIVE, ST PRODUCTS ARE NOT RECOMMENDED, AUTHORIZED OR WARRANTED FOR USE IN MILITARY, AIR CRAFT, SPACE, LIFE SAVING, OR LIFE SUSTAINING APPLICATIONS, NOR IN PRODUCTS OR SYSTEMS WHERE FAILURE OR MALFUNCTION MAY RESULT IN PERSONAL INJURY, DEATH, OR SEVERE PROPERTY OR ENVIRONMENTAL DAMAGE. ST PRODUCTS WHICH ARE NOT SPECIFIED AS "AUTOMOTIVE GRADE" MAY ONLY BE USED IN AUTOMOTIVE APPLICATIONS AT USER'S OWN RISK.**

Resale of ST products with provisions different from the statements and/or technical features set forth in this document shall immediately void any warranty granted by ST for the ST product or service described herein and shall not create or extend in any manner whatsoever, any liability of ST.

ST and the ST logo are trademarks or registered trademarks of ST in various countries.

Information in this document supersedes and replaces all information previously supplied.

The ST logo is a registered trademark of STMicroelectronics. All other names are the property of their respective owners.

© 2009 STMicroelectronics - All rights reserved

STMicroelectronics group of companies

Australia - Belgium - Brazil - Canada - China - Czech Republic - Finland - France - Germany - Hong Kong - India - Israel - Italy - Japan - Malaysia - Malta - Morocco - Singapore - Spain - Sweden - Switzerland - United Kingdom - United States of America

[www.st.com](http://www.st.com)