

LDS6100/6120 Touch Family

PureTouch® Capacitance Touch IC Family with Integrated LED Drivers

The IDT LDS6100/6120 family of PureTouch® controllers empower system designers to create streamlined, attractive and reliable product designs with capacitive touch controls. Integrated LED drivers allow visual feedback to be implemented when a touch occurs, without the need for host intervention.

Benefits

- Ease-of-use and flexible configurability with optimized, state machine architecture
- Longer battery life enabled with ultra-low power consumption
- Low BOM cost and minimized solution footprint using bare minimum of external components
- Robust touch performance via proprietary noise-filtering algorithms
- Customizable visual feedback effects with integrated LED drivers (LDS6120)

Applications

- Mobile handsets and smartphones
- Personal media players (MP3/MP4)
- Gaming devices
- Remote controls
- Television, audio/video
- Set-top boxes, multi-function printers, enterprise telephony
- White goods
- Industrial and medical devices

Description

The LDS6100/6120 family of capacitance touch controllers from Integrated Device Technology® is optimized for the implementation of touch-based input controls including sliders, scroll wheels and buttons. A low power programmable capacitance-to-digital converter (CDC) supports up to 20 sensor inputs, 10 of which may be configured as direct communication mode (DCM) outputs that emulate mechanical buttons, enabling streamlined communication of touch events without the need to query the serial interface bus.

When configured for capacitive sensing, the touch inputs are directed through an integrated switch matrix to a sigma-delta CDC which senses changes in the external sensor array. When a change in capacitance occurs above the user defined threshold, a touch event is recognized and the host processor is notified via an interrupt pin or DCM output. On the LDS6120 products, a variety of built-in LED lighting effects may be automatically initiated by a touch event with no processor intervention required.

On-chip calibration logic continuously monitors the environment and automatically adjusts touch sensitivity to insure robust performance. Proprietary noise-filtering algorithms may also be activated to prevent false sensor activation in noisy system environments. The LDS6100/6120 family is offered with SPI-compatible, I²C-compatible and SMBus-compatible interfaces, selectable in real-time using the I/F select pins. General-purpose input/output (GPIO) and interrupt outputs are also provided for additional communication with the host processor.

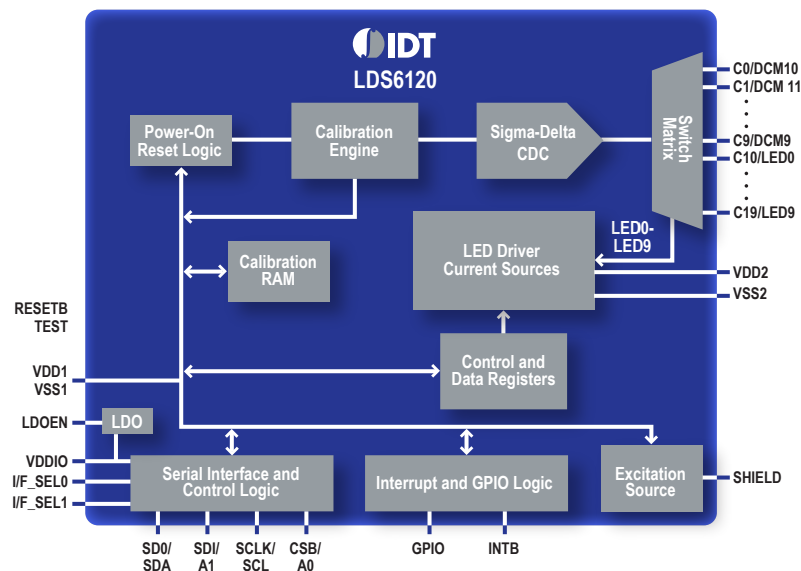
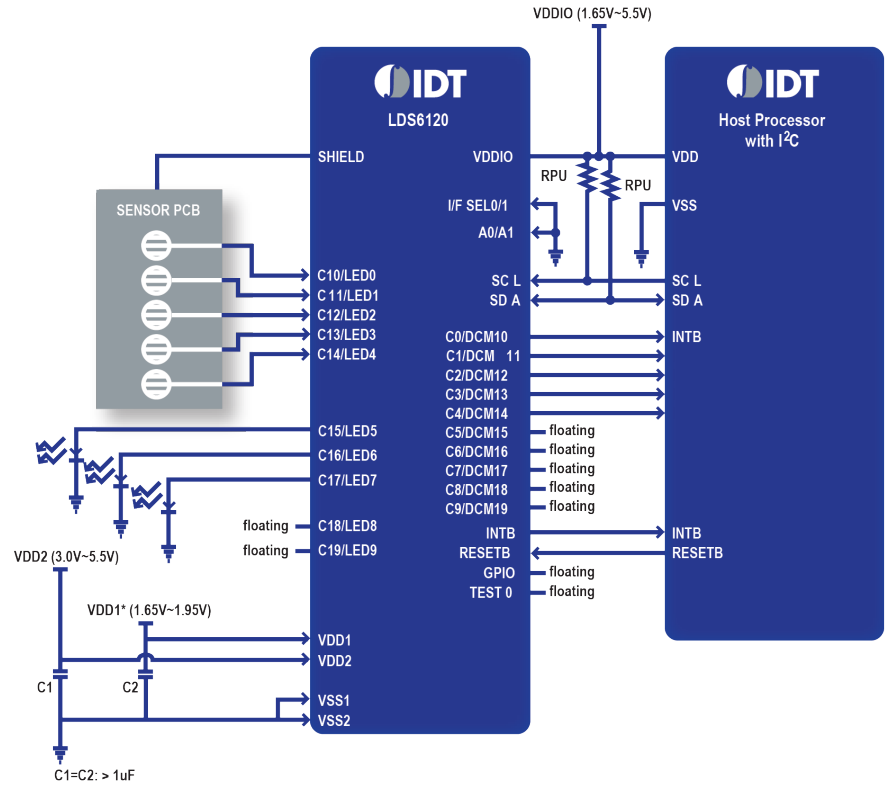

Figure 1. LDS6120 block diagram

Ideal Solution for Portable and “Green” Applications

The LDS6100/6120 is optimized for ultra-low power consumption. In full power mode, sensor conversion and calibration occur continuously, minimizing the time between touch event and touch detection. With its ultra-low touch sensor current consumption of <70 μA (typical at 1.8V), the LDS6100 products may be operated continuously in full power mode, eliminating the need for introduced latencies that can cause noticeable delays and degrade the user experience. Where power consumption is of the utmost importance, low power modes with configurable latencies may be utilized to further reduce current below 25 μA (100ms sleep cycle).

The LDS6100/6120 family is optimized for a minimized solution footprint, with the functionality of multiple components consolidated into a single device and a bare minimum of required external passive components. A variety of package options are available including a 4mm x 4mm 28 lead TQFN package, a 5mm x 5mm 40 lead TQFN package (both with 0.75mm package thickness), or a 5.3mm x 10.2mm SSOP package for applications requiring a wider lead pitch.



*For direct application of 1.8V voltage. For voltages higher than 1.8V, apply voltage to VDDIO and tie VDD1 to ground through C2.

Figure 2. LDS6120 application diagram (typical)

LDS 6100 / 6120 Features	
Versatile, accurate CDC	<ul style="list-style-type: none"> Up to 20 capacitance sensor input channels Configurable hysteresis and debounce
Ultra-low touch sensor power consumption	<ul style="list-style-type: none"> Full power operating mode (typical): <125 μW (VDD1=1.8V) Low power operating mode (typical): <50 μW (VDD1=1.8V, 100ms sleep cycle) Shutdown mode (typical): <1 μW (VDD1=1.8V)
Integrated, automatic calibration algorithms	<ul style="list-style-type: none"> Auto environmental compensation Integrated noise immunity algorithms for high-EMI applications
Integrated touch preference modes	<ul style="list-style-type: none"> Strongest single touch / two touches Unrestricted (all) touches
Built-in slider/scroll support	<ul style="list-style-type: none"> Location, scroll direction, and 2x interpolation supported natively

Integrated LED drivers (LDS6120)

- Up to 10 dual-purpose sensor inputs configurable as LED drivers
- 7.75 mA maximum current per driver (drivers may be combined for higher current applications)
- Flexible dimming control
- Built-in blink, heartbeat effects
- Individual LED configurability
- Host-free synchronization with touch events

Integrated Feature-Rich LED Drivers (LDS6120)

The LDS6120 products integrate a feature rich, highly configurable LED driver, enabling the implementation of visual feedback for touch-based controls and fun lighting effects using a single controller. The minimum and maximum current, transition times, and desired effect are programmable on an individual LED basis, allowing for customized LED behavior for individual buttons. LEDs may be either synchronized to automatically trigger when a touch event occurs or manually controlled using the host processor.

Flexible interface options

- SPI, I²C, and SMBus-compatible serial I/F options
- DCM outputs for mechanical switch emulation
- VDDIO level for serial interface
- GPIO and Interrupt Outputs

Flexible package options

- 28 pin—4mm x 4mm QFN
- 40 pin—5mm x 5mm QFN
- 28 pin—5.3mm x 10.2mm SSOP

Power supply range

- Touch supply (VDD1): 1.65V–5.5V *
- LED supply (VDD2): 3.0V–5.5V
- VDDIO = 1.65V–5.5V

* Supply voltages > 1.95V are applied to VDDIO pin

Feature Enhancements

Part Number	Functionality			Integrated Features			Package
	Touch Sensors	DCM Outputs	LED Drivers	Built-in Slider/Scroll	Built-in LED Effects	Full Hysteresis and Debounce Configurability	
LDS6104	Up to 8	Up to 4		✓		✓	28ld TQFN
LDS6107	Up to 13	Up to 5		✓		✓	28ld SSOP
LDS6108	Up to 16	Up to 8		✓		✓	40ld TQFN
LDS6100	Up to 20	Up to 10		✓		✓	40ld TQFN
LDS6124	Up to 8	Up to 4	Up to 4	✓	✓	✓	28ld TQFN
LDS6126	Up to 11	Up to 5	Up to 6	✓	✓	✓	28ld SSOP
LDS6128	Up to 16	Up to 8	Up to 8	✓	✓	✓	40ld TQFN
LDS6120	Up to 20	Up to 10	Up to 10	✓	✓	✓	40ld TQFN

Figure 3. The LDS 6100/6120 Touch Sensor family includes over 20 enhanced features

You can depend on IDT

Three decades of inventing the technology our markets demand gives IDT the knowledge base to supply our customers with low power, mixed signal semiconductor solutions that enhance the digital media experience. Our diverse and extensive product line, including timing, switching, interconnect, audio and display products empowers leading OEMs to pursue technological advances in communications, computing and consumer market applications with IDT engineers at their side. Service, support and innovation: that's IDT.

Discover what IDT know-how can do for you.

www.IDT.com/go/Touch6100



© 2009 Integrated Device Technology, Inc. All rights reserved. Product specifications subject to change without notice. IDT and the IDT logo are registered trademarks of Integrated Device Technology, Inc. All other brands, product names and marks are or may be trademarks or registered trademarks used to identify products or services of their respective owners.

Printed in USA 12-09/MG/TDA/PDF/r3v1

FLYR-TOUCHfam-129