

ZXF36L01

VARIABLE Q FILTER

DESCRIPTION

The ZXF36L01 is a versatile analog high Q bandpass filter. The device contains two sections:

- 1 Variable Q bandpass filter.
- 2 Mixer block.

The basic filter section requires 2 resistors and 2 capacitors to set the centre frequency. The filter operates up to a frequency of 150kHz. Two external resistors control filter Q Factor. The Q can be varied up to 50.

The mixer is included to extend the frequency range up to 700kHz and to permit the centre frequency to be tuned. The local oscillator can be any waveform, making microprocessor control convenient.

APPLICATIONS

Many filter applications including:-

- Audio bandpass and notch
- Micro controlled frequency
- Adaptive filtering
- Sonar and Ultrasonic Systems
- Instrumentation

FEATURES AND BENEFITS

- Centre Frequency up to 700kHz
- Tuneable centre frequency
- Variable Q
- Low power
- Standby mode for improved battery life

ORDERING INFORMATION

PART NUMBER	PACKAGE	PART MARK
ZXF36L01W24	SO24W	ZXF36L01

PART NUMBER	CONTAINER	INCREMENT
ZXF36L01W24TC	Reel 13" 330mm	1000
ZXF36L01W24	Tube	31

SYSTEM DIAGRAM

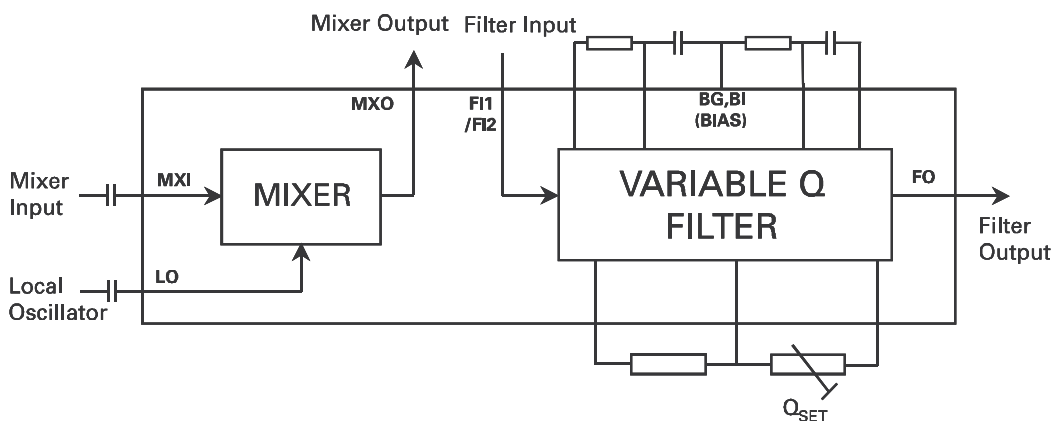

ISSUE 3 - JANUARY 2002

ZXF36L01

ABSOLUTE MAXIMUM RATINGS

Voltage on any pin	7.0V (relative to V _{SS})
Operating temperature range	0 to 70°C (de-rated for -40 to 85°C)
Storage temperature	-55 to 125°C

ELECTRICAL CHARACTERISTICS

Test Conditions: Temperature = 25°C, V_{DD} = 5.00V, V_{SS} = 0.00V

GENERAL CHARACTERISTICS					
Parameter	Conditions	Min.	Typical	Max.	Units
Operating current	$\overline{PD} = V_{DD}$	2.2	3.4	4.5	mA
Shutdown current	$\overline{PD} = V_{SS}$		160	300	μA
I _{IH} (\overline{PD})	V _{IH} = 5V (WRT V _{SS})			1.0	μA
I _{IL} (\overline{PD})	V _{IL} = 0V (WRT V _{SS})	-1.0			μA
FILTER CHARACTERISTICS					
Max. operating frequency				150	kHz
Q usable range		0.5		50	
Centre frequency temperature coefficient	Q=30, f _o = 1kHz Note 1		10		ppm/°C
Average Q temperature coefficient	Q=30, f _o = 1kHz Note 2		0.1		% /°C
Voltage noise	1 – 100 kHz		20		nV/√ Hz
Input impedance		30		50	kΩ
Max. output swing	Output load ≥ 10 kΩ		1.6		V pk-pk
Output sink current			150		μA
Output source current			150		μA
MIXER CHARACTERISTICS					
Max. operating frequency			700		kHz
Maximum signal input			300		mV pk-pk
Maximum Local Oscillator input			100		mV pk-pk
Minimum Local Oscillator input			5		mV pk-pk
Local Oscillator input Impedance			60		Ω

NOTE 1

Centre frequency temperature coefficient is dominated by the external R & C components. On chip drift is negligible.

Note 2

Average Q temperature coefficient is dominated by the external R components.



ISSUE 3 - JANUARY 2002

ZXF36L01

TYPICAL ELECTRICAL CHARACTERISTICS

Test Conditions: $V_{DD} = 5.00V$, $V_{SS} = 0.00V$

Typical Gain at f_o V Q Factor ($f_o = 140$ KHz)

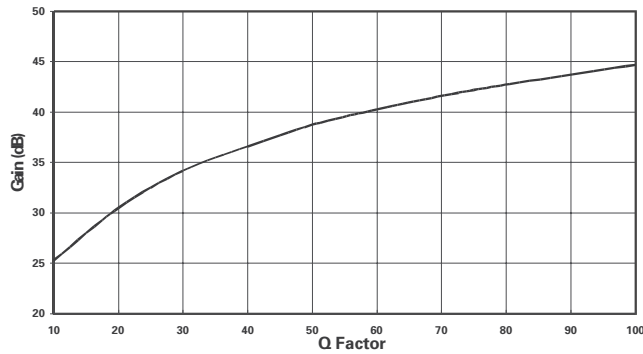

Gain at f_o describes the peak gain of the notch pass filter. This gain is defined by the value of Q Factor.

Q Factor V Frequency

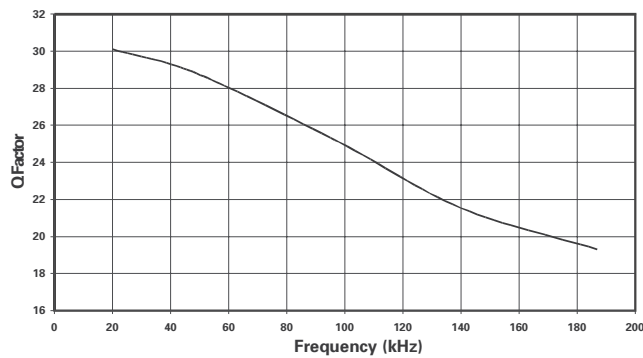

The curve shows Q Factor over frequency for a fixed loop gain (R_f/R_i).

Q Factor V Temperature

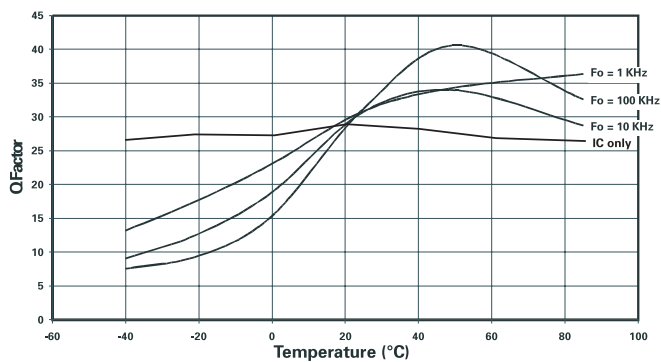

Components used: 1/8 watt metal film resistors (± 50 ppm). Ceramic capacitors (± 50 ppm).

ZXF36L01

DESCRIPTION OF PIN FUNCTIONS

V _{DD}	Positive supply connection (5 volts). Both pins to be connected. To be decoupled with a 100nF capacitor to V _{SS} .
V _{SS}	Negative supply connection; system ground (0 volts). Both pins to be connected.
BG	Bias Generator output. To be decoupled with a 100nF capacitor to V _{SS} .
BI	Bias inputs for internal circuitry, both to be connected to BG. (or external supply referenced to V _{SS})
$\overline{\text{PD}}$	Active low. This feature can be used to reduce power consumption for applications that have a standby mode.
FI1,FI2	Filter input, FI1 or FI2 depending on filter configuration.
FO	Filter output for all configurations.
LO	Local Oscillator signal input.
MXI	Mixer signal input.
MXO	Mixer signal output.
C1, RC1	Phase advance network nodes. Values R and C set centre frequency, fo.
R2, RC2	Phase retard network nodes. Values R and C set centre frequency, fo.
GP1,2,3	Loop gain programming nodes.

CONNECTION DIAGRAM

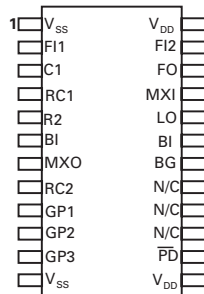

ISSUE 3 - JANUARY 2002

ZXF36L01

FILTER CONFIGURATIONS AND RESPONSES

Notch Filter

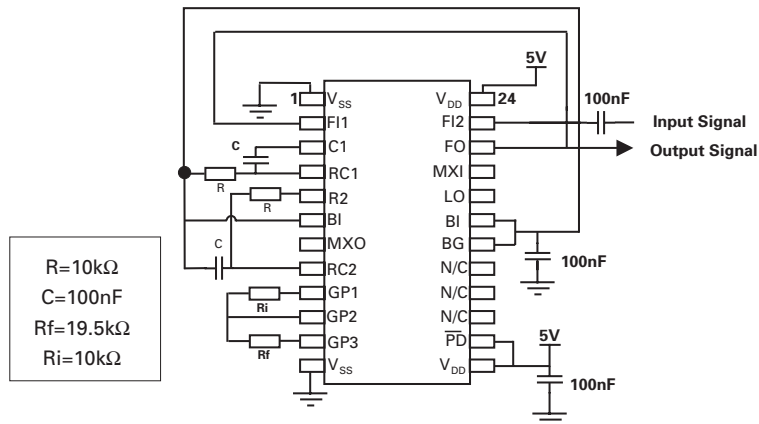

Filter AC Performance

Notch Filter Gain Response

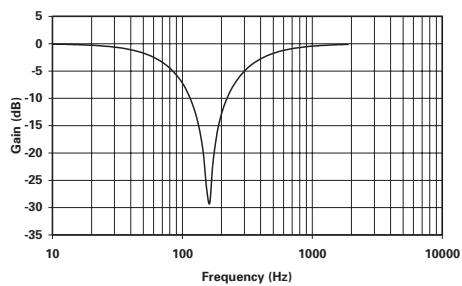

$$f_o = \frac{1}{2\pi RC}$$

$$Q \propto (R_f / R_i)$$

Where R, R_i and $R_f \geq 10k\Omega$ and $C \geq 50$ pF

See "Designing for a Value of Q" for more details.

Notch Filter Phase Response

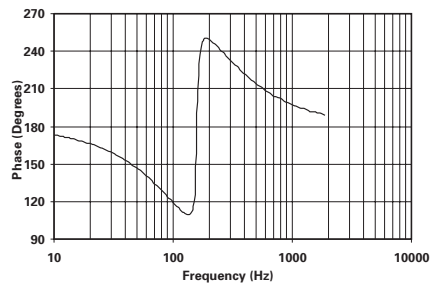

Typical responses for the circuit with component values shown in circuit diagram.

ZXF36L01

FILTER CONFIGURATIONS AND RESPONSES (continued)

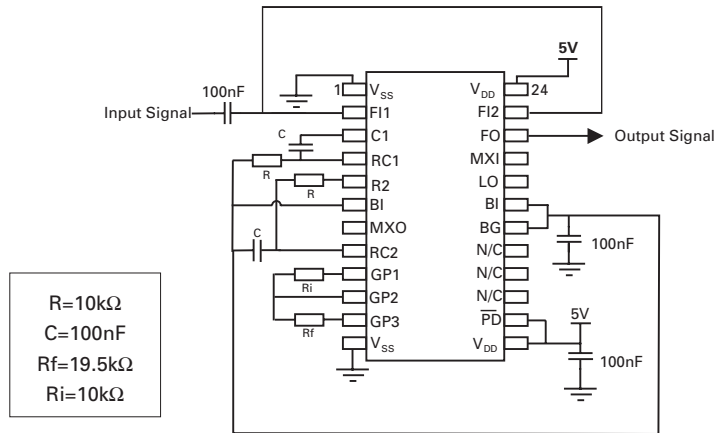

Filter AC Performance

Notch Pass Filter Gain Response

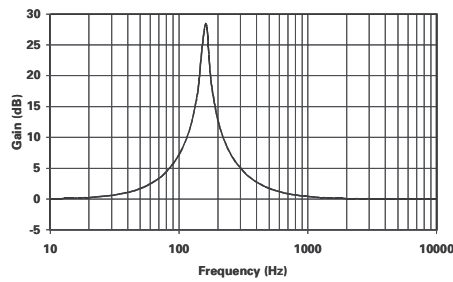

$$f_o = \frac{1}{2\pi RC}$$

$$Q \propto (R_f / R_i)$$

Where R, Ri and Rf ≥ 10kΩ and C ≥ 50 pF

See "Designing for a Value of Q" for more details.

Notch Pass Filter Phase Response

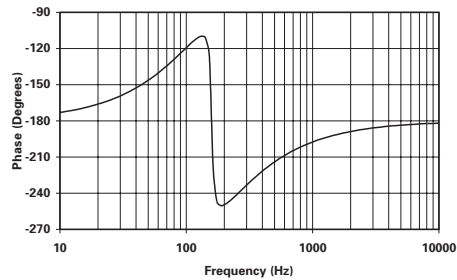

Typical responses for the circuit with component values shown in circuit diagram.



ZXF36L01

FILTER CONFIGURATIONS AND RESPONSES (continued)

Notch Filter (with attenuating skirts)

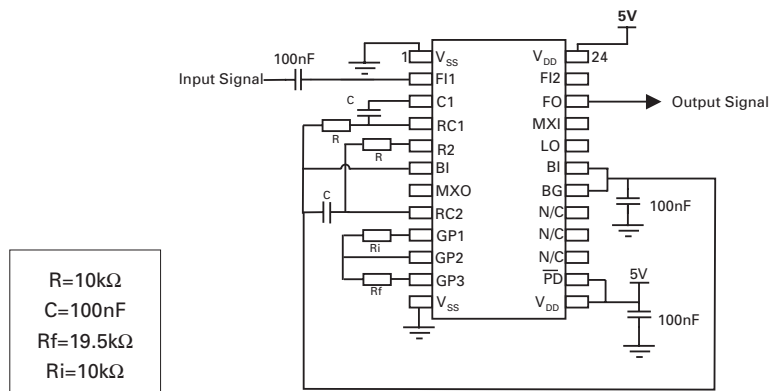

Filter AC Performance

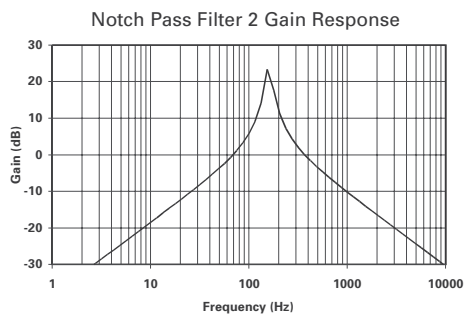

$$f_o = \frac{1}{2\pi RC}$$

$$Q \propto (R_f / R_i)$$

Where R, Ri and Rf ≥ 10kΩ and C ≥ 50 pF

See "Designing for a Value of Q" for more details.

The skirt 'roll off' away from the peak is -20dB/decade regardless of chosen Q.

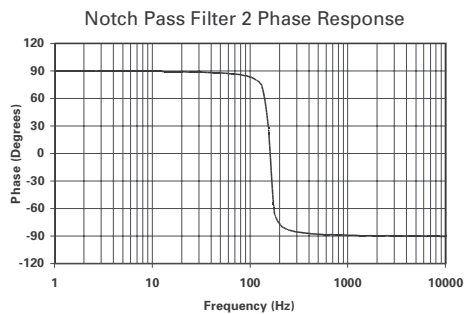

Typical responses for the circuit with component values shown in circuit diagram.

ZXF36L01

DESIGNING FOR A VALUE OF Q

As mentioned on the configuration pages, there is a proportional, but non-linear relationship between the ratio of Rf and Ri, and Q.

These resistors define the gain of an inverting amplifier that determines the peak value gain and therefore the Q of the filter, Q is defined as:

$$Q = \frac{f_o}{-3dB \text{ Bandwidth}}$$

This value of required gain is critical. As the maximum value of Q is approached, too much gain will cause the filter to oscillate at the centre frequency, fo. A small reduction of gain will cause the value of Q to fall significantly. Therefore, for high values of Q or tight tolerances of lower values of Q, the resistor ratio must be trimmed as shown.

Frequency dependant effects must be accounted for in determining the appropriate gain. As the frequency increases because of internal phase shift effects the effective circuit gain reduces and thus Q Factor reduces.

The frequency effect is not a problem for circuits where the fo remains constant, as the phase shifts are accounted for permanently. For designs where Q is high and fo is to be 'swept', care must be taken that a gain appropriate at the highest frequency does not cause oscillation at the lowest.

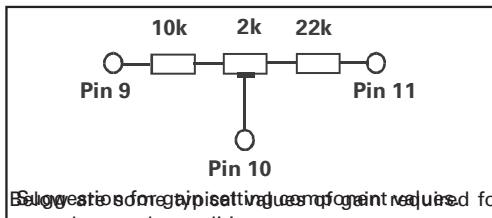

Below are some typical values required for several example conditions:

Example1

fo = 48kHz, R = 10kΩ, C = 320pF
Q=60, Rf/Ri = 36.6kΩ / 18 kΩ => 2.033

Example2

fo = 140kHz, R = 10kΩ, C = 100pF
Q=15, Rf/Ri = 37kΩ / 18kΩ => 2.055

It can be seen from these examples that the higher Q example actually has a lower inverting amplifier gain. As mentioned before, the frequency will affect the value of gain. The Q Factor v Frequency graph illustrates this effect.

These examples show that the gain required is nominally 2. For the specified range of Q: 0.5 to 50 (values up to 250 are obtainable), the gain values vary from 1.9 to 2.5 correspondingly.

Due to internal gain errors, when the absolute value of Q is increased, the device to device variation in Q will also increase.

Q Factor v Feedback Gain

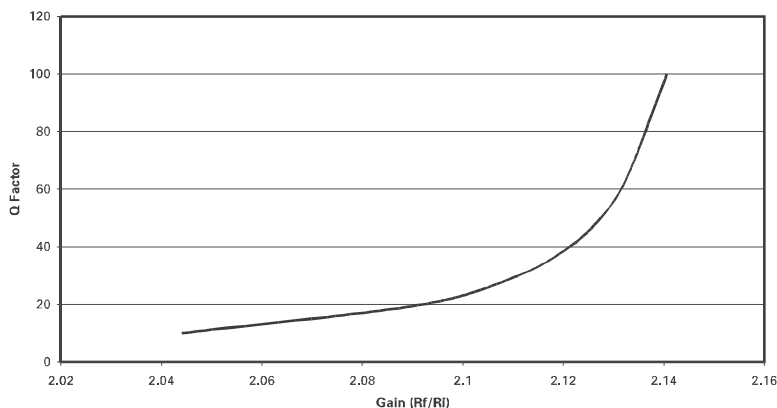

This diagram shows the exponential relationship between gain and Q Factor. (fo = 140 kHz)



ISSUE 3 - JANUARY 2002

ZXF36L01

FILTERING HIGHER FREQUENCIES USING THE MIXER

Frequencies above 150 kHz cannot be filtered directly; the mixer enables the notch pass filter to function up to 700kHz.

The signal to be filtered is mixed with another frequency (local oscillator), chosen so that the difference (intermediate) frequency equals the filter's centre frequency, f_0 . The local oscillator signal waveform can be of any shape (sine, square, etc.) but must be approximately 50% duty cycle.

Example

Input frequency = 300 kHz, Local Oscillator (LO) frequency = 250 kHz,

Output (IF) Frequency = 50 kHz.

If the bandwidth of the 50 kHz filter were 1 kHz, the filter's Q factor would be:

$$50/1 = 50.$$

The bandwidth of the filter is still 1 kHz when 300 kHz is applied to the mixer's input, but now the Q factor is:

$$300/1 = 300.$$

The mixer provides a Q factor improvement equal to the ratio of the input frequency and the intermediate frequency.

The effective centre frequency can also be externally controlled by changing the LO frequency. This allows frequency tuning, trimming or sweeping while employing fixed resistors and capacitors for the filter.

As the LO signal can be a square wave, this allows 'fo' to be controlled using a microcontroller or microprocessor.

MIXER CONFIGURATION WITH NOTCH PASS FILTER (with attenuating skirts)

The mixer can only be used with this filter configuration, as the other types have 0dB stop bands. The mixer output 'MXO' becomes the input of the filter.

As the gain of the notch filter changes with Q, the output of the mixer must be attenuated by some factor (VR_{Atten}). This will prevent the filter from being overdriven and allows the user to set the required output level.

Note: As the local oscillator input, LO has a low input impedance (60Ω), it will often be necessary to increase it for driving circuitry. As the input voltage required is low (around 5 mV pk-pk min.), a series resistor ' R_{Mixer} ' can be inserted. A value of $1 \text{ k}\Omega$ per 100mV (pk) oscillator signal input will be suitable.

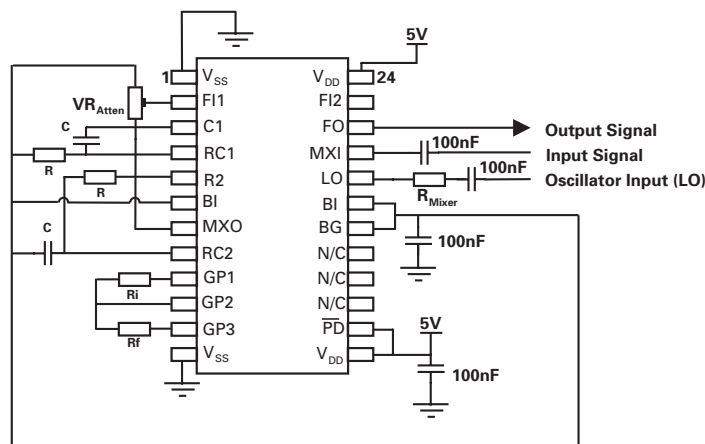

ZXF36L01

Application Note

An assembled evaluation PCB is available from Zetex Plc, part code: ZXF36L01-EVB. It provides a fast and easy way of testing the filter configurations mentioned in this datasheet. This board is configured for 10kHz operation.

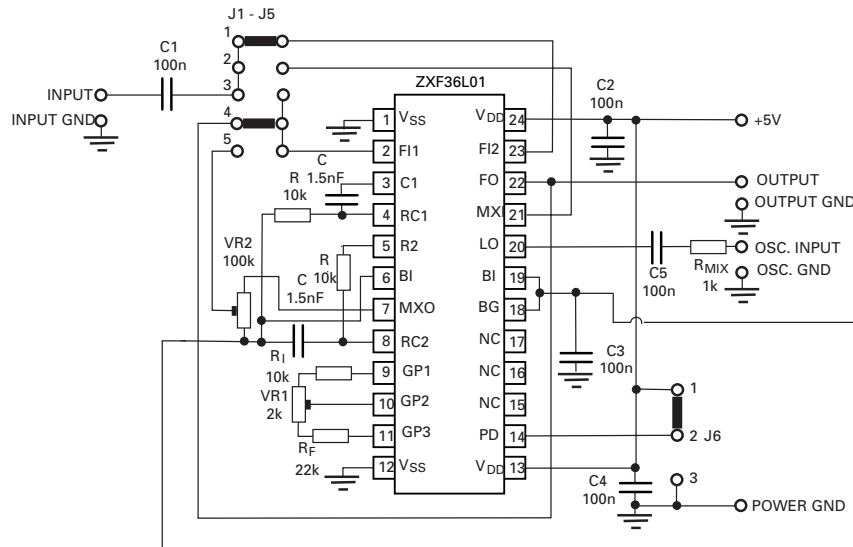

JUMPER SETTINGS

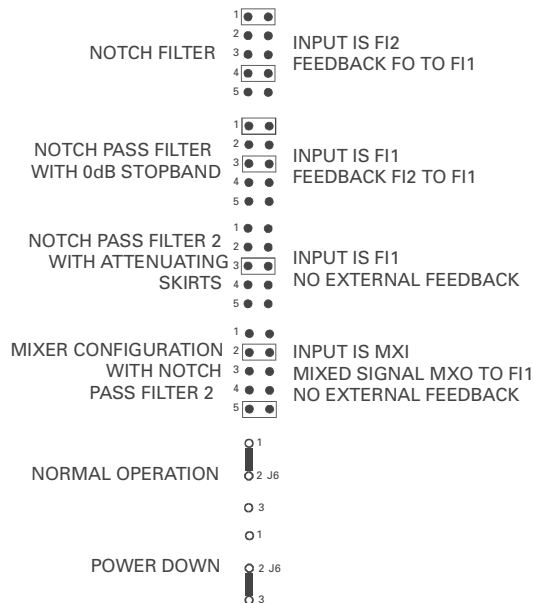

ISSUE 3 - JANUARY 2002

ZXF36L01

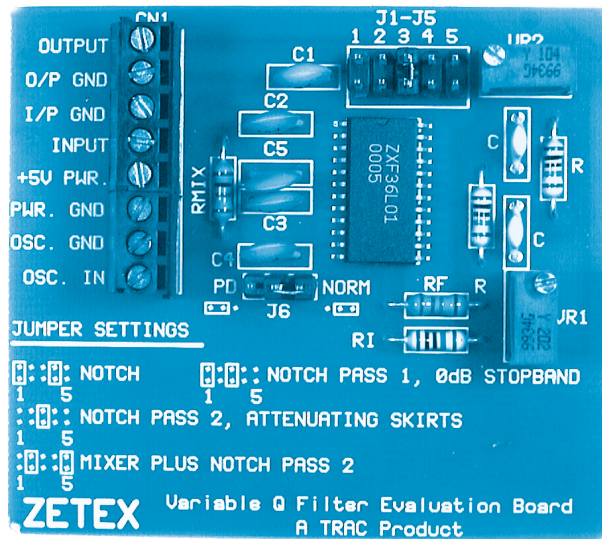

Evaluation

An evaluation board (ZXF36L01-EVB) is available to assist with in-system or stand-alone performance evaluation. The board can be set, by simple jumper links, to perform any of the filter characteristic responses. The mixer can be selected in conjunction with the notch pass filter 2 functions.

Evaluation boards can be purchased from our catalogue distributors.

Digi-Key North America (www.digikey.com)
Tel:1-800344-4539

Europe - Farnell (www.farnell.com)
Tel:44-113-263-6311

ZXF36L01

PACKAGE DIMENSION

DIM	Millimetres		Inches	
	Min	Max	Min	Max
A	15.20	15.40	0.598	0.606
B	1.27	-	0.05	-
C	0.66	-	0.026	-
D	0.36	0.46	0.014	0.018
E	7.40	7.60	0.291	0.299
F	2.44	2.64	0.096	0.104
G	0.10	0.30	0.004	0.012
H	0°	7°	0°	7°
I	0.23	0.28	0.009	0.011
J	10.11	10.51	0.398	0.414
K	0°	8°	0°	8°
L	0.51	1.01	0.02	0.04
R	0.63	0.89	0.025	0.035
a	7°BSC		7°BSC	

PACKAGE OUTLINE

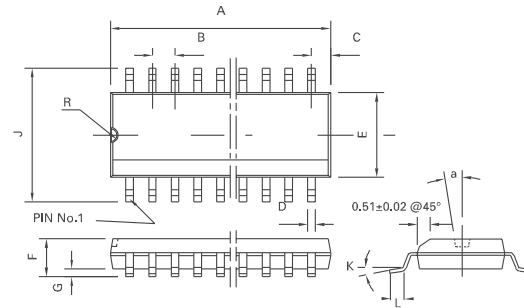

SOIC 24 LEAD

© Zetex plc 2001

Zetex plc Fields New Road Chadderton Oldham, OL9 8NP United Kingdom Telephone (44) 161 622 4422 Fax: (44) 161 622 4420	Zetex GmbH Streitfeldstraße 19 D-81673 München Germany Telefon: (49) 89 45 49 49 0 Fax: (49) 89 45 49 49 49	Zetex Inc 700 Veterans Memorial Hwy Hauppauge, NY11788 USA Telephone: (631) 360 2222 Fax: (631) 360 8222	Zetex (Asia) Ltd 3701-04 Metroplaza, Tower 1 Hing Fong Road Kwai Fong Hong Kong Telephone: (852) 26100 611 Fax: (852) 24250 494
--	--	---	---

These offices are supported by agents and distributors in major countries world-wide.

This publication is issued to provide outline information only which (unless agreed by the Company in writing) may not be used, applied or reproduced for any purpose or form part of any order or contract or be regarded as a representation relating to the products or services concerned. The Company reserves the right to alter without notice the specification, design, price or conditions of supply of any product or service.

For the latest product information, log on to www.zetex.com



ISSUE 3 - JANUARY 2002