

DS55113/DS75113 Dual TRI-STATE® Differential Line Driver

General Description

The DS55113/DS75113 dual differential line drivers with TRI-STATE outputs are designed to provide all the features of the DS55114/DS75114 line drivers with the added feature of driver output controls. There are individual controls for each output pair, as well as a common control for both output pairs. When an output control is low, the associated output is in a high-impedance state and the output can neither drive nor load the bus. This permits many devices to be connected together on the same transmission line for party-line applications.

The output stages are similar to TTL totem-pole outputs, but with the sink outputs, YS and ZS, and the corresponding active pull-up terminals, YP and ZP, available on adjacent package pins.

Features

- Each circuit offers a choice of open-collector or active pull-up (totem-pole) outputs
- Single 5V supply
- Differential line operation
- Dual channels
- TTL/LS compatibility
- High-impedance output state for party-line applications
- Short-circuit protection
- High current outputs
- Single-ended or differential AND/NAND outputs
- Common and individual output controls
- Clamp diodes at inputs
- Easily adaptable to DS55114/DS75114 applications

Connection Diagram

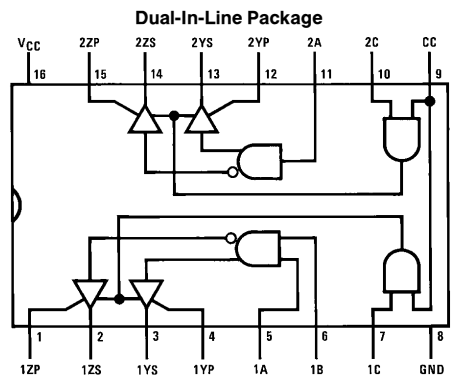

Positive logic: $Y = AB$
 $Z = \overline{AB}$
Output is OFF when
C or CC is low

TL/F/5785-1

Top View

Order Number DS55113J, DS75113M or DS75113N
See NS Package Number J16A, M16A or N16A

For Complete Military 883 Specifications, see RETS Datasheet.
Order Number DS55113J/883
See NS Package Number J16A

Truth Table

Inputs				Outputs	
Output Control		Data		AND	NAND
C	CC	A	B*	Y	Z
L	X	X	X	Z	Z
X	L	X	X	Z	Z
H	H	L	X	L	H*
H	H	X	L	L	H
H	H	H	H	H	L

H = high level
L = low level
X = irrelevant
Z = high impedance (OFF)
*B input and 4th line of truth table applicable only to driver number 1

TRI-STATE® is a registered trademark of National Semiconductor Corp.

Absolute Maximum Ratings (Note 1)

If Military/Aerospace specified devices are required, please contact the National Semiconductor Sales Office/Distributors for availability and specifications.

Supply Voltage (V_{CC}) (Note 1)	7V
Input Voltage	5.5V
OFF-State Voltage Applied to Open-Collector Outputs	12V
Maximum Power Dissipation* at 25°C	
Cavity Package	1433 mW
Molded DIP Package	1362 mW
SO Package	1002 mW

Operating Free-Air Temperature Range	
DS55113	-55°C to +125°C
DS75113	0°C to +70°C

*Derate cavity package 9.6 mW/°C above 25°C; derate molded DIP package 10.9 mW/°C above 25°C; derate SO package 8.01 mW/°C above 25°C (Note 2).

Storage Temperature Range	-65°C to +150°C
Lead Temperature (1/16" from case for 60 seconds): J Package	300°C
Lead Temperature (1/16" from case for 4 seconds): N Package	260°C

Operating Conditions

	Min	Max	Units
Supply Voltage (V_{CC})			
DS55113	4.5	5.5	V
DS75113	4.75	5.25	V
High Level Output Current (I_{OH})		-40	mA
Low Level Output Current (I_{OL})		40	mA
Operating Free-Air Temperature (T_A)			
DS55113	-55	125	°C
DS75113	0	70	°C

Electrical Characteristics Over recommended operating free-air temperature range (unless otherwise noted)

Symbol	Parameter	Conditions (Note 3)	DS55113			DS75113			Units		
			Min	Typ (Note 4)	Max	Min	Typ (Note 4)	Max			
V_{IH}	High Level Input Voltage		2			2			V		
V_{IL}	Low Level Input Voltage				0.8			0.8	V		
V_{IK}	Input Clamp Voltage	$V_{CC} = \text{Min}, I_I = -12 \text{ mA}$		-0.9	-1.5		-0.9	-1.5	V		
V_{OH}	High Level Output Voltage	$V_{CC} = \text{Min}, V_{IH} = 2V, V_{IL} = 0.8V$	$I_{OH} = -10 \text{ mA}$	2.4	3.4		2.4	3.4	V		
			$I_{OH} = -40 \text{ mA}$	2	3.0		2	3.0			
V_{OL}	Low Level Output Voltage	$V_{CC} = \text{Min}, V_{IH} = 2V, V_{IL} = 0.8V, I_{OL} = 40 \text{ mA}$		0.23	0.4		0.23	0.4	V		
V_{OK}	Output Clamp Voltage	$V_{CC} = \text{Max}, I_O = -40 \text{ mA}$		-1.1	-1.5		-1.1	-1.5	V		
$I_{O(\text{off})}$	Off-State Open-Collector Output Current	$V_{CC} = \text{Max}$	$V_{OH} = 12V$	$T_A = 25^\circ\text{C}$		1	10			μA	
				$T_A = 125^\circ\text{C}$			200				
			$V_{OH} = 5.25V$	$T_A = 25^\circ\text{C}$				1	10		
				$T_A = 70^\circ\text{C}$					20		
I_{OZ}	Off-State (High-Impedance-State) Output Current	$V_{CC} = \text{Max}, \text{Output Controls at } 0.8V$	$T_A = 25^\circ\text{C}, V_O = 0 \text{ to } V_{CC}$				± 10		± 10	μA	
				$T_A = \text{Max}$				± 150			± 20
			$V_O = 0V$				± 80		± 20		
			$V_O = 0.4V$				± 80		± 20		
			$V_O = 2.4V$				80		20		
I_I	Input Current at Maximum Input Voltage	A, B, C CC	$V_{CC} = \text{Max}, V_I = 5.5V$				1		1	mA	
							2		2		
I_{IH}	High Level Input Current	A, B, C CC	$V_{CC} = \text{Max}, V_I = 2.4V$				40		40	μA	
							80		80		
I_{IL}	Low Level Input Current	A, B, C CC	$V_{CC} = \text{Max}, V_I = 0.4V$				-1.6		-1.6	mA	
							-3.2		-3.2		

Electrical Characteristics

Over recommended operating free-air temperature range (unless otherwise noted) (Continued)

Symbol	Parameter	Conditions (Note 3)	DS55113			DS75113			Units
			Min	Typ (Note 4)	Max	Min	Typ (Note 4)	Max	
I_{OS}	Short-Circuit Output Current (Note 5)	$V_{CC} = \text{Max}, V_O = 0V$	-40	-90	-120	-40	-90	-120	mA
I_{CC}	Supply Current (Both Drivers)	All Inputs at 0V, No Load $T_A = 25^\circ\text{C}$	$V_{CC} = \text{Max}$	47	65		47	65	mA
			$V_{CC} = 7V$	65	85		65	85	

Note 1: All voltage values are with respect to network ground terminal.

Note 2: For operation above 25°C free-air temperature, refer to Dissipation Derating Curves in the Thermal information section.

Note 3: All parameters with the exception of OFF-state open-collector output current are measured with the active pull-up connected to the sink output.

Note 4: All typical values are at $T_A = 25^\circ\text{C}$ and $V_{CC} = 5V$, with the exception of I_{CC} at 7V.

Note 5: Only one output should be shorted at a time, and duration of the short-circuit should not exceed one second.

Switching Characteristics $V_{CC} = 5V, C_L = 30 \text{ pF}, T_A = 25^\circ\text{C}$

Symbol	Parameter	Conditions	DS55113			DS75113			Unit
			Min	Typ	Max	Min	Typ	Max	
t_{PLH}	Propagation Delay Time, Low-to-High-Level Output	<i>(Figure 1)</i>		13	20		13	30	ns
t_{PHL}	Propagation Delay Time, High-to-Low-Level Output			12	20		12	30	ns
t_{PZH}	Output Enable Time to High Level	$R_L = 180\Omega, (Figure 2)$		7	15		7	20	ns
t_{PZL}	Output Enable Time to Low Level	$R_L = 250\Omega, (Figure 3)$		14	30		14	40	ns
t_{PHZ}	Output Disable Time from High Level	$R_L = 180\Omega, (Figure 2)$		10	20		10	30	ns
t_{PLZ}	Output Disable Time from Low Level	$R_L = 250\Omega, (Figure 3)$		17	35		17	35	ns

Schematic Diagram (One side shown only)

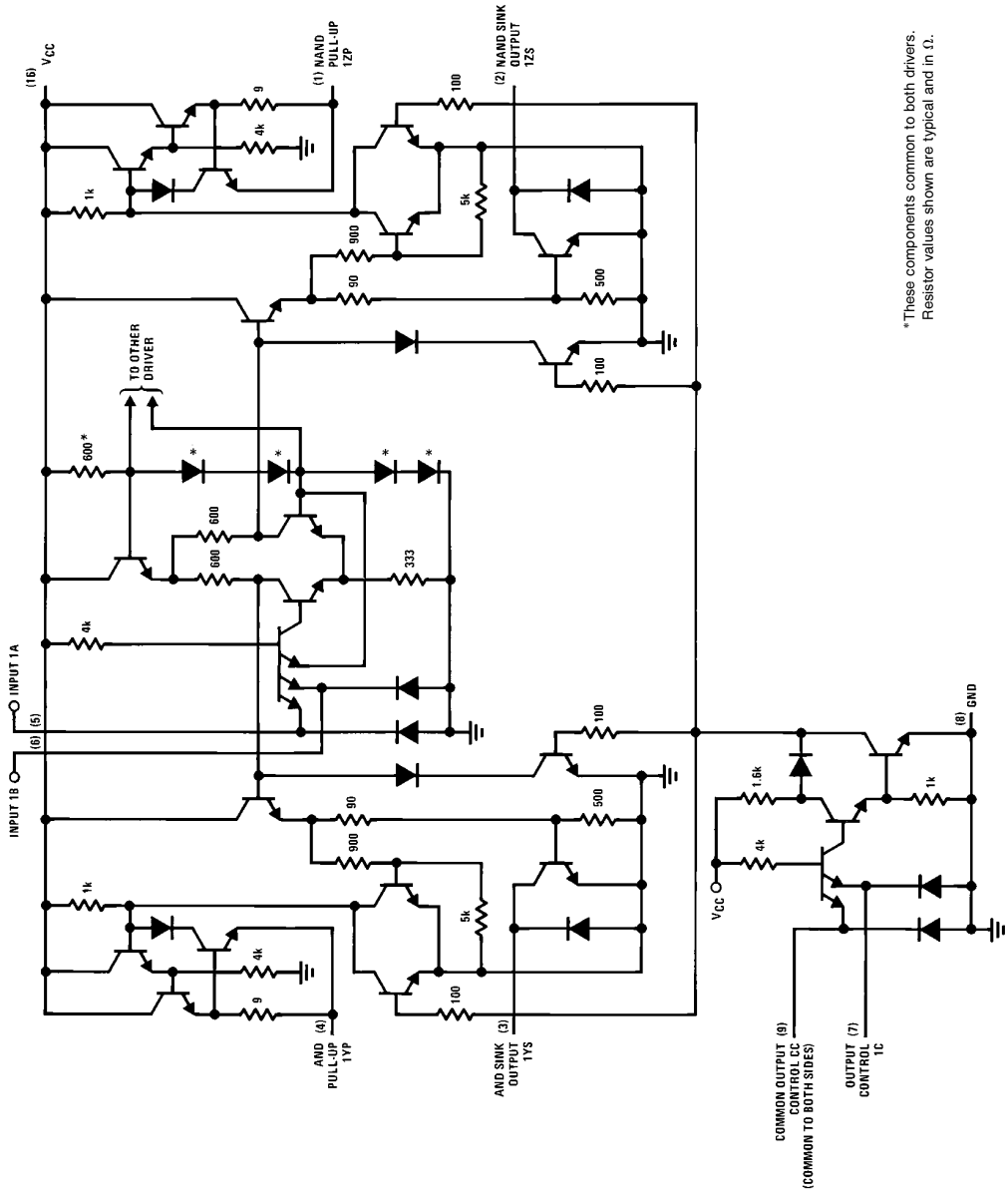

TL/F/5765-2

AC Test Circuits and Switching Time Waveforms

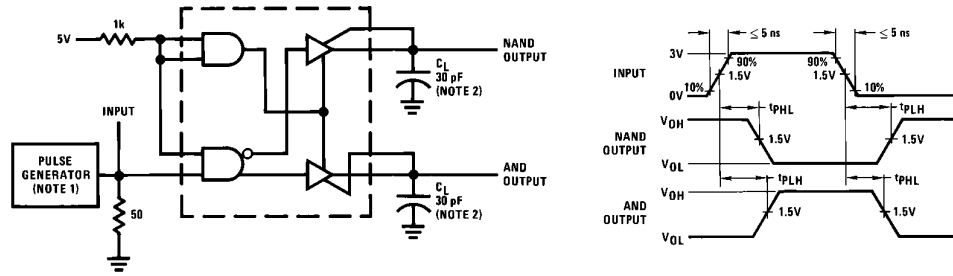

FIGURE 1. t_{PLH} and t_{PHL}

TL/F/5785-3

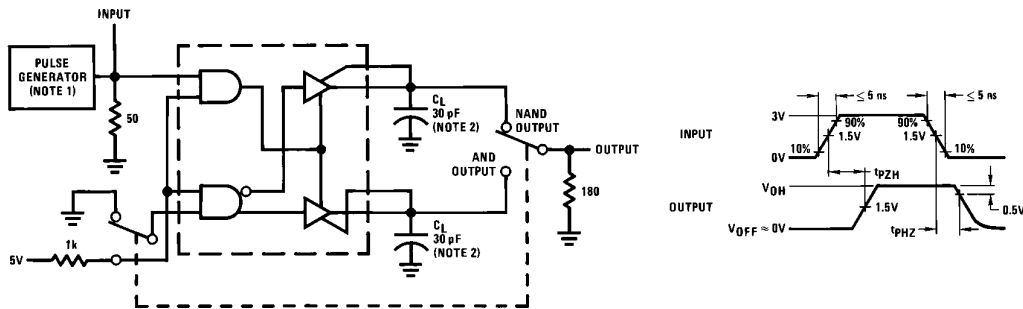

FIGURE 2. t_{PZH} and t_{PHZ}

TL/F/5785-4

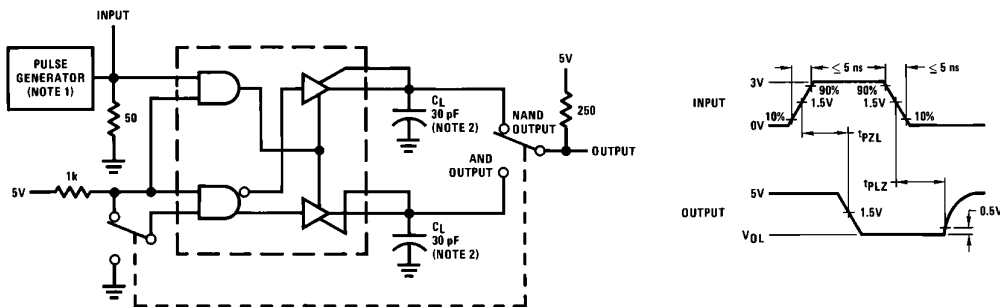

FIGURE 3. t_{PZL} and t_{PLZ}

TL/F/5785-5

Note 1: The pulse generator has the following characteristics: $Z_{OUT} = 50\Omega$, $PRR = 500\text{ kHz}$, $t_W = 100\text{ ns}$.

Note 2: C_L includes probe and jig capacitance.

Typical Performance Characteristics*

Output Voltage vs Output Control Voltage

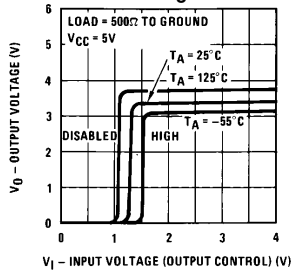

Output Voltage vs Output Control Voltage

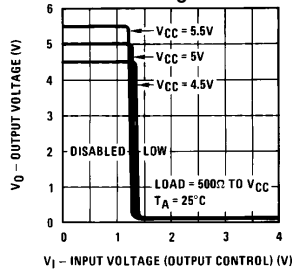

Output Voltage vs Output Control Voltage

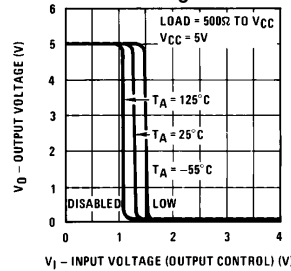

Output Voltage vs Free-Air Temperature

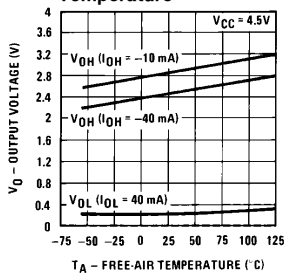

High Level Output Voltage vs Output Current

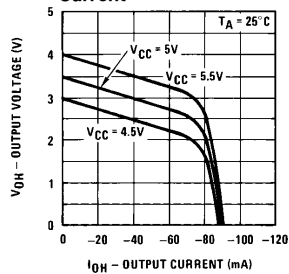

Low Level Output Voltage vs Output Current

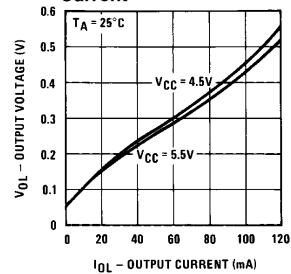

Supply Current (Both Drivers) vs Supply Voltage

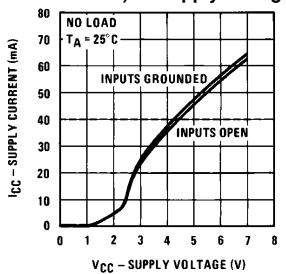

Supply Current (Both Drivers) vs Free-Air Temperature

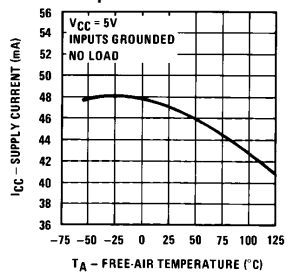

Supply Current (Both Drivers) vs Frequency

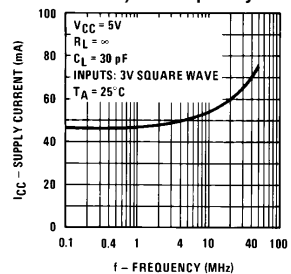

Propagation Delay Times from Data Inputs vs Free-Air Temperature

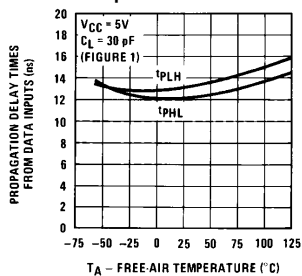

Output Enable and Disable Times vs Free-Air Temperature

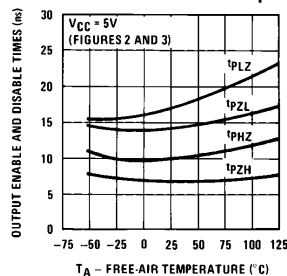

TL/F/5785-7

*Data for temperatures below $0^\circ C$ and above $70^\circ C$ and for supply voltages below 4.75V and above 5.25V are applicable to DS55113 circuits only. These parameters were measured with the active pull-up connected to the sink output.

Typical Performance Characteristics* (Continued)

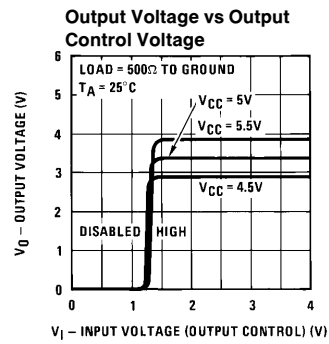
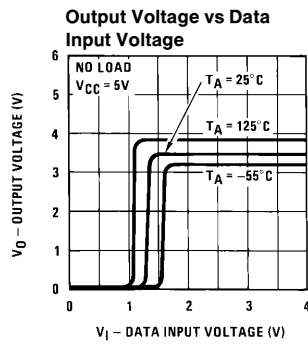
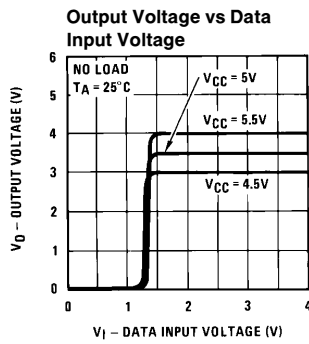

TL/F/5785-6

*Data for temperatures below 0°C and above 70°C and for supply voltages below 4.75V and above 5.25V are applicable to DS55113 circuits only. These parameters were measured with the active pull-up connected to the sink output.

Physical Dimensions inches (millimeters)

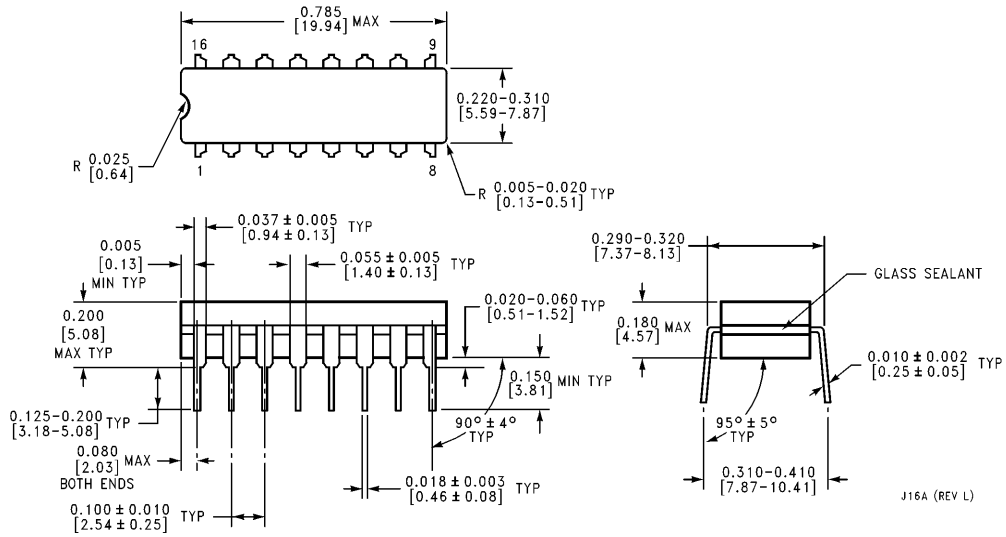

Ceramic Dual-In-Line Package (J)
Order Number DS55113J
NS Package Number J16A

J16A (REV L)

Physical Dimensions inches (millimeters) (Continued)

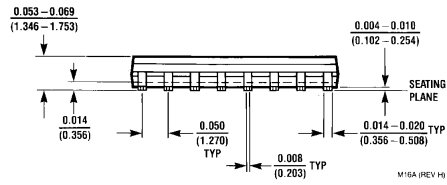
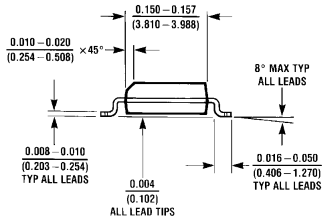
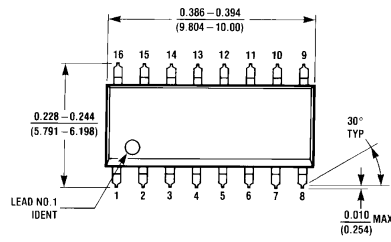

SO Package (M)
Order Number DS75113M
NS Package Number M16A

Physical Dimensions inches (millimeters) (Continued)

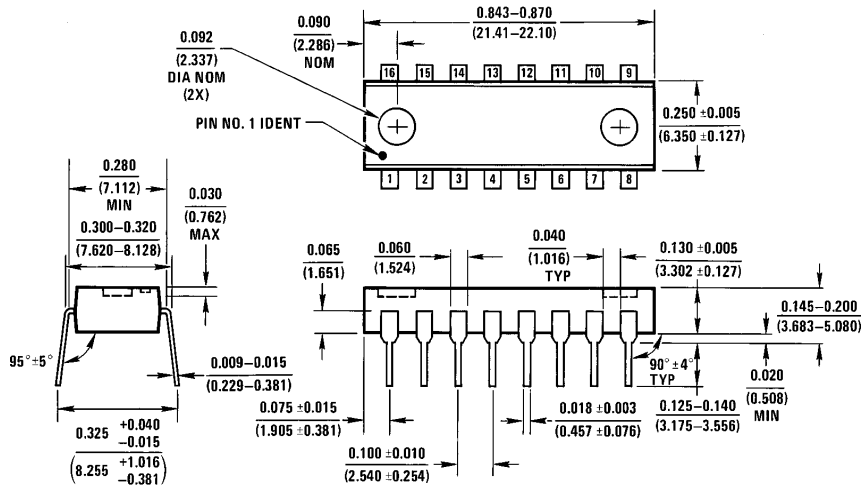

Molded Dual-In-Line Package (N)
Order Number DS75113N
NS Package Number N16A

N16A (REV E)

LIFE SUPPORT POLICY

NATIONAL'S PRODUCTS ARE NOT AUTHORIZED FOR USE AS CRITICAL COMPONENTS IN LIFE SUPPORT DEVICES OR SYSTEMS WITHOUT THE EXPRESS WRITTEN APPROVAL OF THE PRESIDENT OF NATIONAL SEMICONDUCTOR CORPORATION. As used herein:

1. Life support devices or systems are devices or systems which, (a) are intended for surgical implant into the body, or (b) support or sustain life, and whose failure to perform, when properly used in accordance with instructions for use provided in the labeling, can be reasonably expected to result in a significant injury to the user.
2. A critical component is any component of a life support device or system whose failure to perform can be reasonably expected to cause the failure of the life support device or system, or to affect its safety or effectiveness.



National Semiconductor Corporation
 1111 West Bardin Road
 Arlington, TX 76017
 Tel: 1(800) 272-9959
 Fax: 1(800) 737-7018

<http://www.national.com>

National Semiconductor Europe

Fax: +49 (0) 180-530 85 86
 Email: europe.support@nsc.com
 Deutsch Tel: +49 (0) 180-530 85 85
 English Tel: +49 (0) 180-532 78 32
 Français Tel: +49 (0) 180-532 93 58
 Italiano Tel: +49 (0) 180-534 16 80

National Semiconductor Hong Kong Ltd.

19th Floor, Straight Block,
 Ocean Centre, 5 Canton Rd.
 Tsimshatsui, Kowloon
 Hong Kong
 Tel: (852) 2737-1600
 Fax: (852) 2736-9960

National Semiconductor Japan Ltd.

Tel: 81-043-299-2308
 Fax: 81-043-299-2408

National does not assume any responsibility for use of any circuitry described, no circuit patent licenses are implied and National reserves the right at any time without notice to change said circuitry and specifications.