

# DS26F32M

## Quad Differential Line Receivers

### General Description

The DS26F32 is a quad differential line receiver designed to meet the requirements of EIA Standards RS-422 and RS-423, and Federal Standards 1020 and 1030 for balanced and unbalanced digital data transmission.

The DS26F32 offers improved performance due to the use of state-of-the-art L-FAST bipolar technology. The L-FAST technology allows for higher speeds and lower currents by utilizing extremely short gate delay times. Thus, the DS26F32 features lower power, extended temperature range, and improved specifications.

The device features an input sensitivity of 200 mV over the input common mode range of  $\pm 7.0V$ . The DS26F32 provides an enable function common to all four receivers and TRI-STATE<sup>®</sup> outputs with 8.0 mA sink capability. Also, a fail-safe input/output relationship keeps the outputs high when the inputs are open.

The DS26F32 offers optimum performance when used with the DS26F31 Quad Differential Line Driver.

### Features

- Military temperature range
- Input voltage range of  $\pm 7.0V$  (differential or common mode)  $\pm 0.2V$  sensitivity over the input voltage range
- Meets all the requirements of EIA standards RS-422 and RS-423
- High input impedance (18k typical)
- 30 mV input hysteresis
- Operation from single +5.0V supply
- Input pull-down resistor prevents output oscillation on unused channels
- TRI-STATE outputs, with choice of complementary enables, for receiving directly onto a data bus
- Propagation delay 15 ns typical

### Connection Diagram

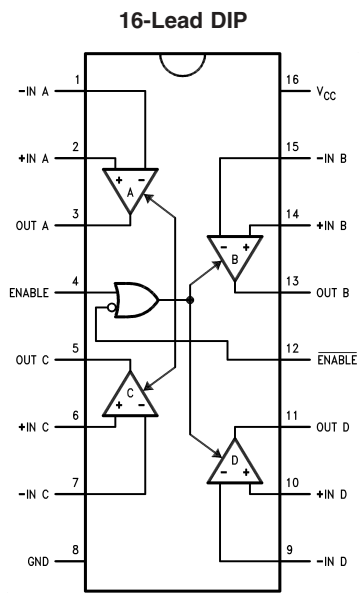

Top View

See NS Package Number J16A  
For Complete Military Product Specifications,  
refer to the appropriate SMD or MDS.  
Order Number DS26F32ME/883,  
DS26F32MJ/883 or DS26F32MW/883  
See NS Package Number E20A, J16A or W16A

20-Lead Ceramic Leadless Chip Carrier

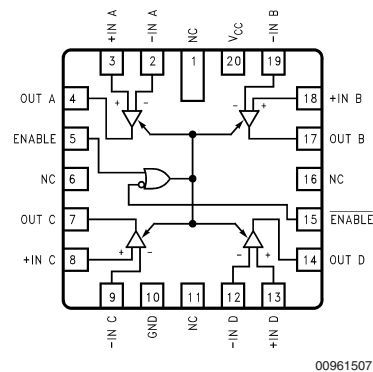

### Function Table

(Each Receiver)

Differential Inputs	Enables	Outputs
$V_{ID} = (V_{IN+}) - (V_{IN-})$	E $\bar{E}$	OUT
$V_{ID} \geq 0.2V$	H    X	H
	X    L	H
$V_{ID} \leq -0.2V$	H    X	L
	X    L	L
X	L    H	Z

H = High Level  
L = Low Level  
X = Immaterial

TRI-STATE<sup>®</sup> is a registered trademark of National Semiconductor Corporation.

**Absolute Maximum Ratings** (Note 2)

If Military/Aerospace specified devices are required, please contact the National Semiconductor Sales Office/Distributors for availability and specifications.

Storage Temperature Range	
Ceramic DIP	-65°C + to 175°C
Operating Temperature Range	
DS26F32M	-55°C to +125°C
DS26F32C	0°C to +70°C
Lead Temperature	
Ceramic DIP (soldering, 60 sec)	300°C
Maximum Power Dissipation (Note 1) at 25°C	

Cavity Package	1500 mW
Supply Voltage	7.0V
Common Mode Voltage Range	±25V
Differential Input Voltage	±25V
Enable Voltage	7.0V
Output Sink Current	50 mA

**Operating Range**

DS26F32M	
Temperature	-55°C to +125°C
Supply Voltage	4.5V to 5.5V

**Note 1:** Derate cavity package 10 mW/°C above 25°C.

**Electrical Characteristics** (Notes 3, 4)

Over operating range, unless otherwise specified

Symbol	Parameter	Conditions	Min	Typ	Max	Units
V <sub>TH</sub>	Differential Input Voltage	-7.0V ≤ V <sub>CM</sub> ≤ +7.0V, V <sub>O</sub> = V <sub>OL</sub> or V <sub>OH</sub>	-0.2	±0.06	+0.2	V
R <sub>I</sub>	Input Resistance	-15V ≤ V <sub>CM</sub> ≤ +15V, One Input AC Ground	14	18		kΩ
I <sub>I</sub>	Input Current (under Test)	V <sub>I</sub> = +15V, Other Input -15V ≤ V <sub>I</sub> ≤ +15V			2.3	mA
		V <sub>I</sub> = -15V, Other Input -15V ≤ V <sub>I</sub> ≤ +15V			-2.8	
V <sub>OH</sub>	Output Voltage HIGH	V <sub>CC</sub> = Min, ΔV <sub>I</sub> = +1.0V, V <sub>ENABLE</sub> = 0.8V, I <sub>OH</sub> = -440 μA	0°C to +70°C	2.8	3.4	V
			-55°C to +125°C	2.5	3.4	
V <sub>OL</sub>	Output Voltage LOW	V <sub>CC</sub> = Min, ΔV <sub>I</sub> = -1.0V, V <sub>ENABLE</sub> = 0.8V	I <sub>OL</sub> = 4.0 mA		0.4	V
			I <sub>OL</sub> = 8.0 mA		0.45	
V <sub>IL</sub>	Enable Voltage LOW				0.8	V
V <sub>IH</sub>	Enable Voltage HIGH		2.0			V
V <sub>IC</sub>	Enable Clamp Voltage	V <sub>CC</sub> = Min, I <sub>I</sub> = -18 mA			-1.5	V
I <sub>OZ</sub>	Off State (High Impedance) Output Current	V <sub>CC</sub> = Max	V <sub>O</sub> = 2.4V		20	μA
			V <sub>O</sub> = 0.4V		-20	
I <sub>IL</sub>	Enable Current LOW	V <sub>I</sub> = 0.4V		-0.2	-0.36	mA
I <sub>IH</sub>	Enable Current HIGH	V <sub>I</sub> = 2.7V		0.5	10	μA
I <sub>I</sub>	Enable Input High Current	V <sub>I</sub> = 5.5V		1.0	50	μA
I <sub>OS</sub>	Output Short Circuit Current	V <sub>O</sub> = 0V, V <sub>CC</sub> = Max, (Note 5) ΔV <sub>I</sub> = +1.0V	-15	-50	-85	mA
I <sub>CC</sub>	Supply Current	V <sub>CC</sub> = Max, All V <sub>I</sub> = GND, Outputs Disabled		30	50	mA
V <sub>HYST</sub>	Input Hysteresis	T <sub>A</sub> = 25°C, V <sub>CC</sub> = 5.0V, V <sub>CM</sub> = 0V		30		mV

**Note 2:** "Absolute Maximum Ratings" are those values beyond which the safety of the device cannot be guaranteed. They are not meant to imply that the devices should be operated at these limits. The tables of "Electrical Characteristics" provide conditions for actual device operation.

**Note 3:** Unless otherwise specified min/max limits apply across the -55°C to +125°C temperature range for the DS26F32M and across the 0°C to +70°C range for the DS26F32C. All typicals are given for V<sub>CC</sub> = 5V and T<sub>A</sub> = 25°C.

**Note 4:** All currents into the device pins are positive; all currents out of the device pins are negative. All voltages are reference to ground unless otherwise specified.

**Note 5:** Only one output at a time should be shorted.

# Switching Characteristics

$V_{CC} = 5.0V, T_A = 25^\circ C$

Symbol	Parameter	Conditions	Min	Typ	Max	Units
$t_{PLH}$	Input to Output	(Figures 2, 3)		15	22	ns
$t_{PHL}$	Input to Output			15	22	ns
$t_{LZ}$	Enable to Output	(Figures 2, 4)		14	18	ns
$t_{HZ}$	Enable to Output			15	20	ns
$t_{ZL}$	Enable to Output			13	18	ns
$t_{ZH}$	Enable to Output			12	16	ns

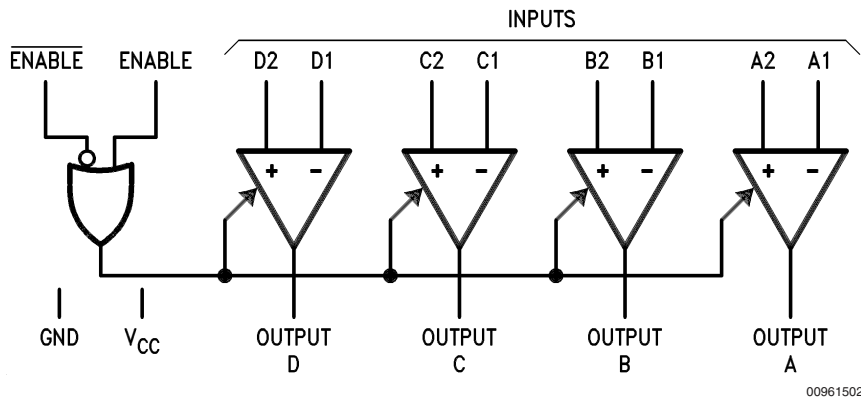

FIGURE 1. Logic Symbol

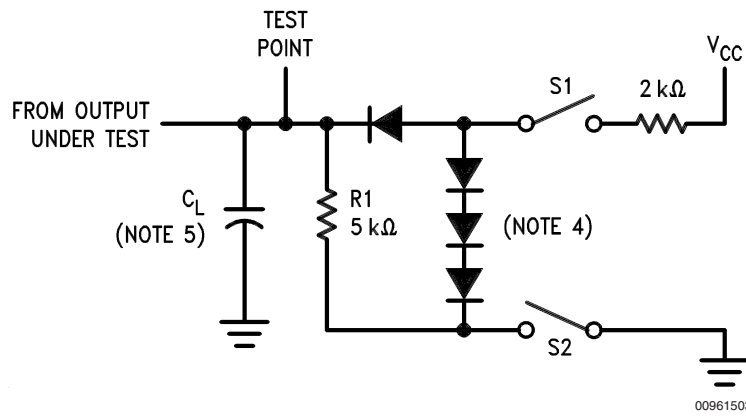

FIGURE 2. Load Test Circuit for Three-State Outputs

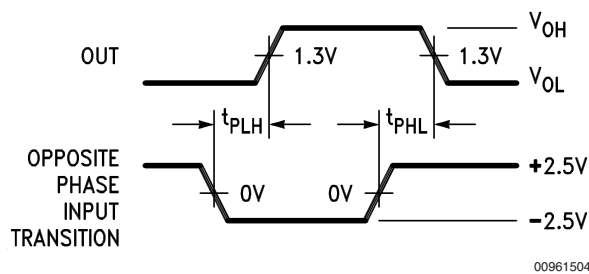
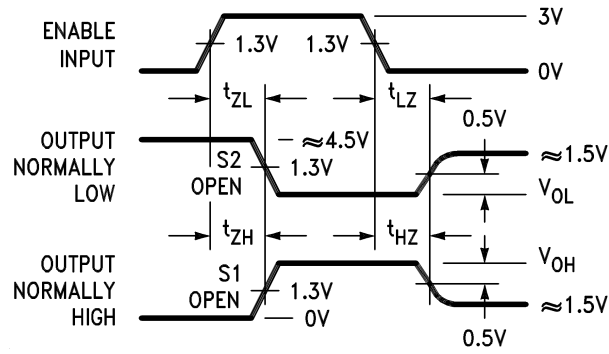

FIGURE 3. Propagation Delay (Notes 6, 7, 8)



00961505

**Note 6:** Diagram shown for  $\overline{\text{ENABLE}}$  Low.

**Note 7:** S1 and S2 of Load Circuit are closed except where shown.

**Note 8:** Pulse Generator of all Pulses: Rate  $\leq 1.0$  MHz,  $Z_O = 50\Omega$ ,  $t_r \leq 6.0$  ns,  $t_f \leq 6.0$  ns.

**Note 9:** All diodes are IN916 or IN3064.

**Note 10:**  $C_L$  includes probe and jig capacitance.

**FIGURE 4. Enable and Disable Times (Notes 6, 7, 8)**

### Typical Application

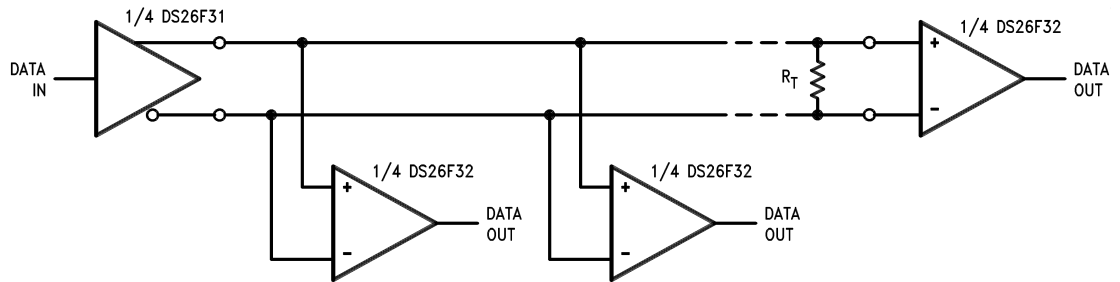

00961506

**FIGURE 5.**

# Physical Dimensions inches (millimeters)

unless otherwise noted

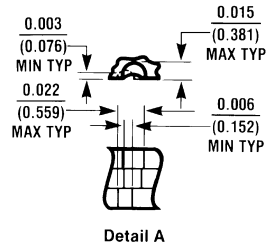
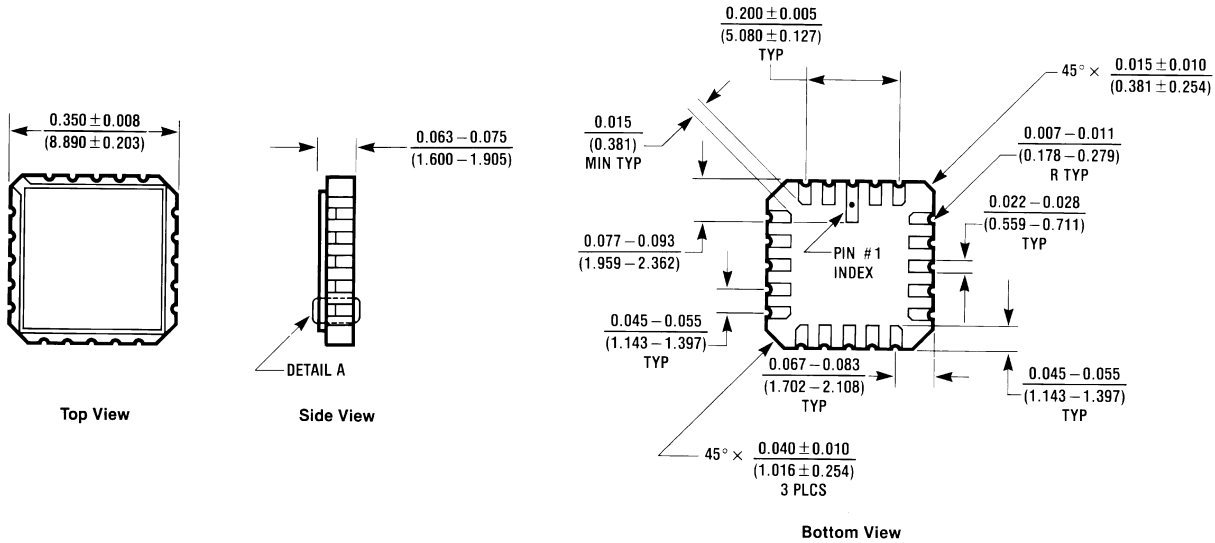

E20A (REV D)

**Order Number DS26F32ME/883**  
**NS Package Number E20A**

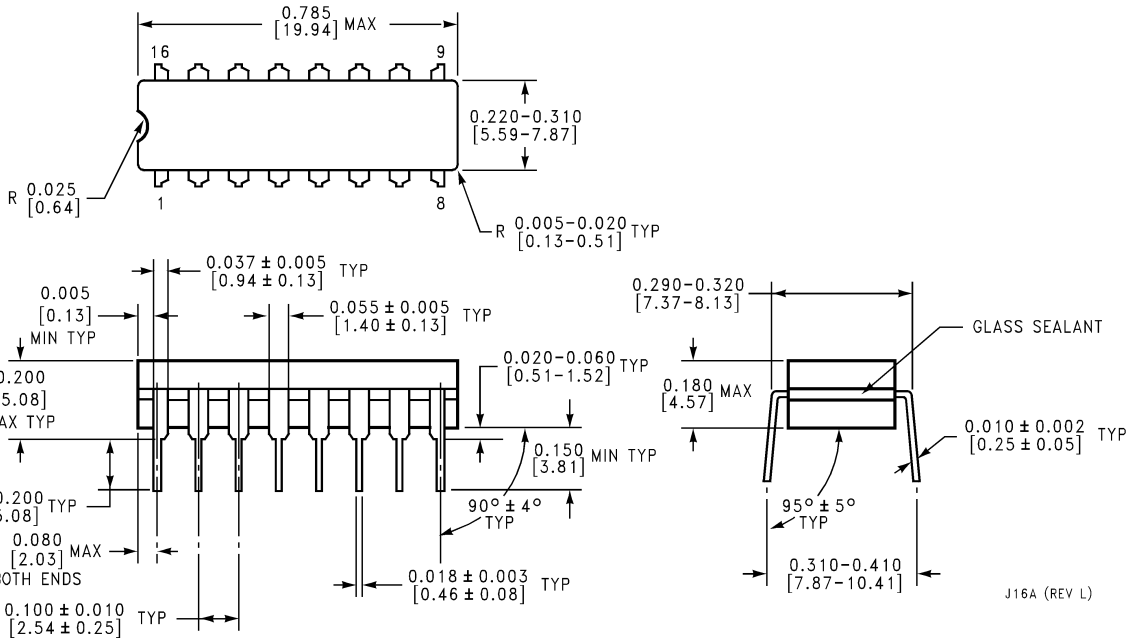

J16A (REV L)

**Ceramic Dual-In-Line Package (J)**  
**Order Number DS26F32MJ/883**  
**NS Package Number J16A**

**Physical Dimensions** inches (millimeters) unless otherwise noted (Continued)

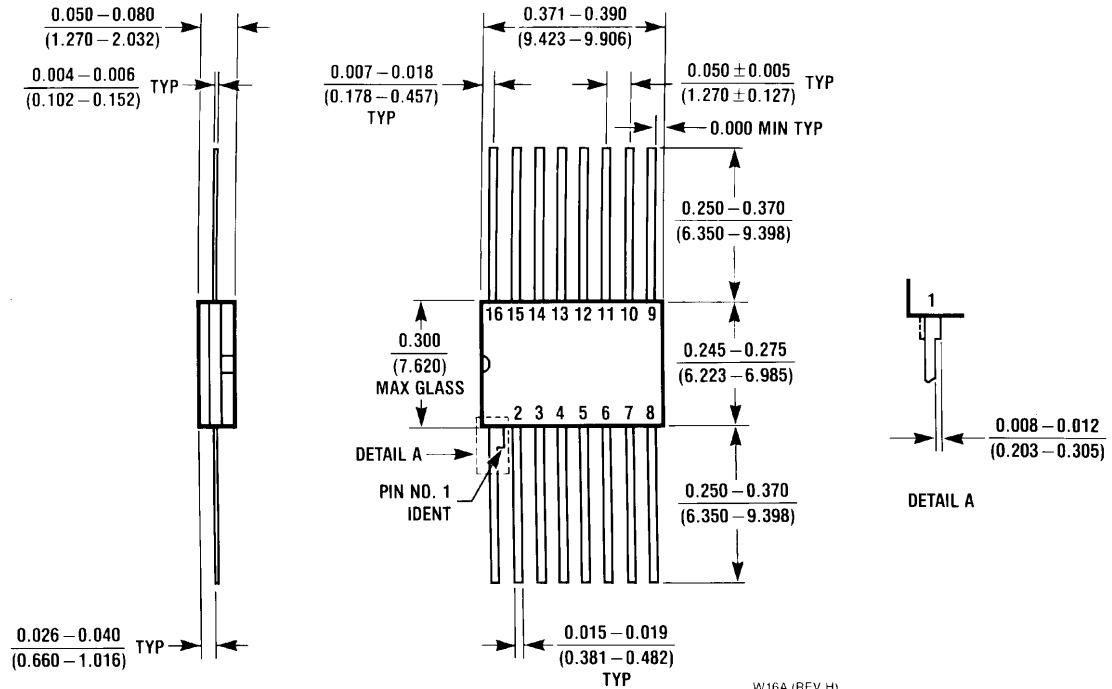

W16A (REV H)

**Order Number DS26F32MW/883**  
**NS Package Number W16A**

**LIFE SUPPORT POLICY**

NATIONAL'S PRODUCTS ARE NOT AUTHORIZED FOR USE AS CRITICAL COMPONENTS IN LIFE SUPPORT DEVICES OR SYSTEMS WITHOUT THE EXPRESS WRITTEN APPROVAL OF THE PRESIDENT AND GENERAL COUNSEL OF NATIONAL SEMICONDUCTOR CORPORATION. As used herein:

1. Life support devices or systems are devices or systems which, (a) are intended for surgical implant into the body, or (b) support or sustain life, and whose failure to perform when properly used in accordance with instructions for use provided in the labeling, can be reasonably expected to result in a significant injury to the user.
2. A critical component is any component of a life support device or system whose failure to perform can be reasonably expected to cause the failure of the life support device or system, or to affect its safety or effectiveness.

**BANNED SUBSTANCE COMPLIANCE**

National Semiconductor certifies that the products and packing materials meet the provisions of the Customer Products Stewardship Specification (CSP-9-111C2) and the Banned Substances and Materials of Interest Specification (CSP-9-111S2) and contain no "Banned Substances" as defined in CSP-9-111S2.



**National Semiconductor**  
**Americas Customer Support Center**  
 Email: new.feedback@nsc.com  
 Tel: 1-800-272-9959

**National Semiconductor**  
**Europe Customer Support Center**  
 Fax: +49 (0) 180-530 85 86  
 Email: europe.support@nsc.com  
 Deutsch Tel: +49 (0) 69 9508 6208  
 English Tel: +44 (0) 870 24 0 2171  
 Français Tel: +33 (0) 1 41 91 8790

**National Semiconductor**  
**Asia Pacific Customer Support Center**  
 Email: ap.support@nsc.com

**National Semiconductor**  
**Japan Customer Support Center**  
 Fax: 81-3-5639-7507  
 Email: jpn.feedback@nsc.com  
 Tel: 81-3-5639-7560

www.national.com

National does not assume any responsibility for use of any circuitry described, no circuit patent licenses are implied and National reserves the right at any time without notice to change said circuitry and specifications.