

DS7830/DS8830 Dual Differential Line Driver

General Description

The DS7830/DS8830 is a dual differential line driver that also performs the dual four-input NAND or dual four-input AND function.

TTL (Transistor-Transistor-Logic) multiple emitter inputs allow this line driver to interface with standard TTL systems. The differential outputs are balanced and are designed to drive long lengths of coaxial cable, strip line, or twisted pair transmission lines with characteristic impedances of 50Ω to 500Ω. The differential feature of the output eliminates troublesome ground-loop errors normally associated with single-wire transmissions.

Features

- Single 5V power supply
- Diode protected outputs for termination of positive and negative voltage transients
- Diode protected inputs to prevent line ringing
- High speed
- Short circuit protection

Connection Diagram

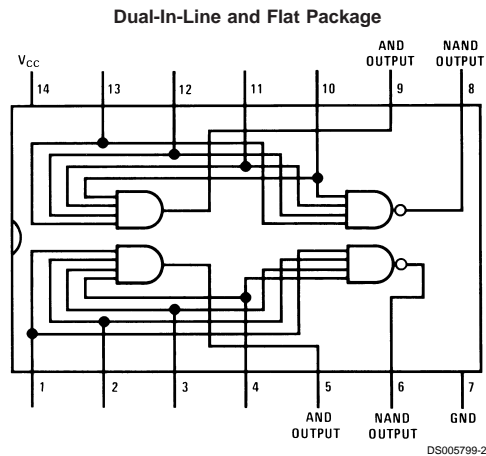

Top View

Order Number DS8830N

See NS Package Number N14A

For Complete Military 883 Specifications, See RETS Data Sheet.

Order Number DS7830J/883 or DS7830W/883

See NS Package Number J14A

Absolute Maximum Ratings (Note 2)

If Military/Aerospace specified devices are required, please contact the National Semiconductor Sales Office/Distributors for availability and specifications.

V_{CC}	7.0V
Input Voltage	5.5V
Storage Temperature	-65°C to +150°C
Lead Temperature (Soldering, 4 sec.)	260°C
Output Short Circuit Duration (125°C)	1 second
Maximum Power Dissipation (Note 1) at 25°C	
Cavity Package	1308 mW
Molded Package	1207 mW

Operating Conditions

	Min	Max	Units
Supply Voltage (V_{CC})			
DS8730	4.5	5.5	V
DS8830	4.75	5.25	V
Temperature (T_A)			
DS7830	-55	+125	°C
DS8830	0	+70	°C

Note 1: Derate cavity package 8.7 mW/°C above 25°C; derate molded package 9.7 mW/°C above 25°C.

Electrical Characteristics (Notes 3, 4)

Symbol	Parameter	Conditions	Min	Typ	Max	Units	
V_{IH}	Logical "1" Input Voltage		2.0			V	
V_{IL}	Logical "0" Input Voltage				0.8	V	
V_{OH}	Logical "1" Output Voltage	$V_{IN} = 0.8V$	$I_{OUT} = -0.8 mA$	2.4			V
			$I_{OUT} = 40 mA$	1.8	3.3		V
V_{OL}	Logical "0" Output Voltage	$V_{IN} = 2.0V$	$I_{OUT} = 32 mA$		0.2	0.4	V
			$I_{OUT} = 40 mA$		0.22	0.5	V
I_{IH}	Logical "1" Input Current	$V_{IN} = 2.4V$			120	μA	
		$V_{IN} = 5.5V$			2	mA	
I_{IL}	Logical "0" Input Current	$V_{IN} = 0.4V$			-4.8	mA	
I_{SC}	Output Short Circuit Current	$V_{CC} = 5.0V, T_A = 125^\circ C, (Note 5)$	-40	-100	-120	mA	
I_{CC}	Supply Current	$V_{IN} = 5.0V, (Each Driver)$		11	18	mA	
V_I	Input Clamp	$V_{CC} = Min, I_{IN} = -12 mA$		-1.0	-1.5	V	

Switching Characteristics

$T_A = 25^\circ C, V_{CC} = 5V$, unless otherwise noted

Symbol	Parameter	Conditions	Min	Typ	Max	Units
t_{pd1}	Propagation Delay AND Gate	$R_L = 400\Omega, C_L = 15 pF$ (Figure 1)		8	12	ns
t_{pd0}				11	18	ns
t_{pd1}	Propagation Delay NAND Gate	$R_L = 400\Omega, C_L = 15 pF$ (Figure 1)		8	12	ns
t_{pd0}				5	8	ns
t_1	Differential Delay	Load, 100 Ω and 5000 pF, (Figure 2)		12	16	ns
t_2	Differential Delay	Load, 100 Ω and 5000 pF, (Figure 2)		12	16	ns

Note 2: "Absolute Maximum Ratings" are those values beyond which the safety of the device cannot be guaranteed. Except for "Operating Temperature Range" they are not meant to imply that the devices should be operated at these limits. The table of "Electrical Characteristics" provides conditions for actual device operation.

Note 3: Unless otherwise specified min/max limits apply across the -55°C to +125°C temperature range for the DS7830 and across the 0°C to +70°C range for the DS8830. Typical values for $T_A = 25^\circ C$ and $V_{CC} = 5.0V$.

Note 4: All currents into device pins shown as positive, out of device pins as negative, all voltages referenced to ground unless otherwise noted. All values shown as max or min on absolute value basis.

Note 5: Only one output at a time should be shorted.

AC Test Circuit and Switching Time Waveforms

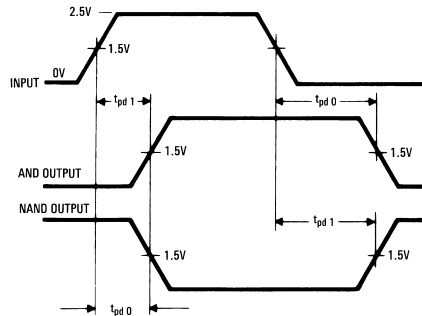
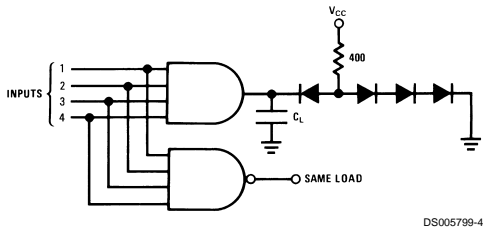

$f = 1 \text{ MHz}$
 $t_r = t_f \leq 10 \text{ ns}$ (10% to 90%)
 Duty cycle = 50%

FIGURE 1.

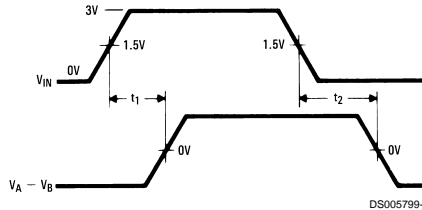
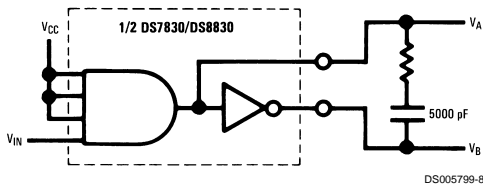
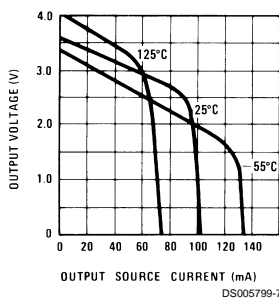

FIGURE 2.

Typical Performance Characteristics

Output High Voltage (Logical "1") vs Output Current



Differential Delay vs Temperature

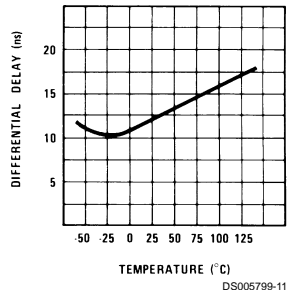

Threshold Voltage vs Temperature

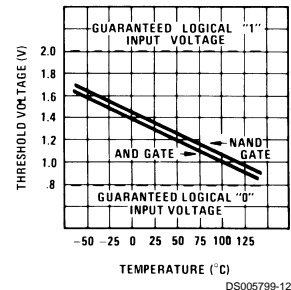

Typical Performance Characteristics (Continued)

Differential Output Voltage
 $(|V_{AND} - V_{NAND}|)$ vs
Differential Output Current

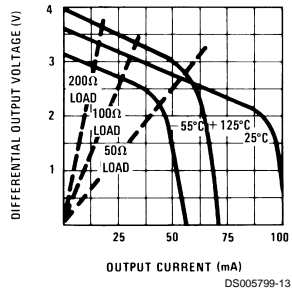

Power Dissipation (No Load)
vs Data Input Frequency

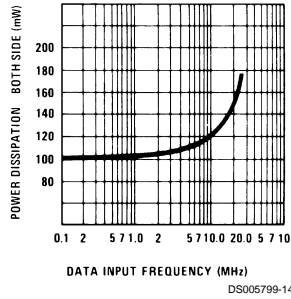

Output Low Voltage
(Logical "0") vs
Output Current

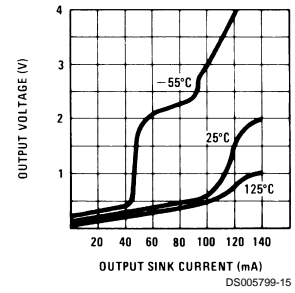

Typical Application

Digital Data Transmission

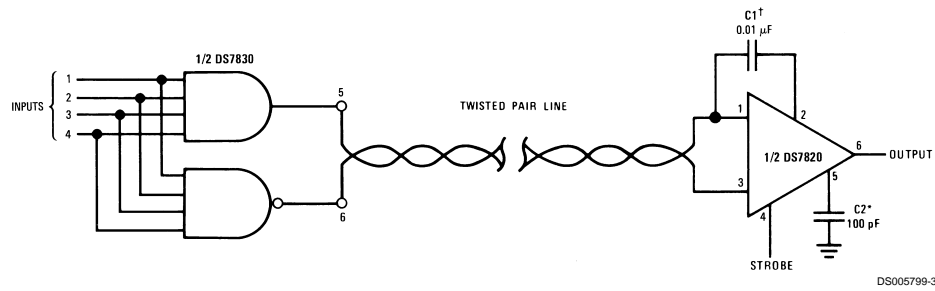

†Exact value depends on line length.
 *Optional to control response time.

Schematic Diagram

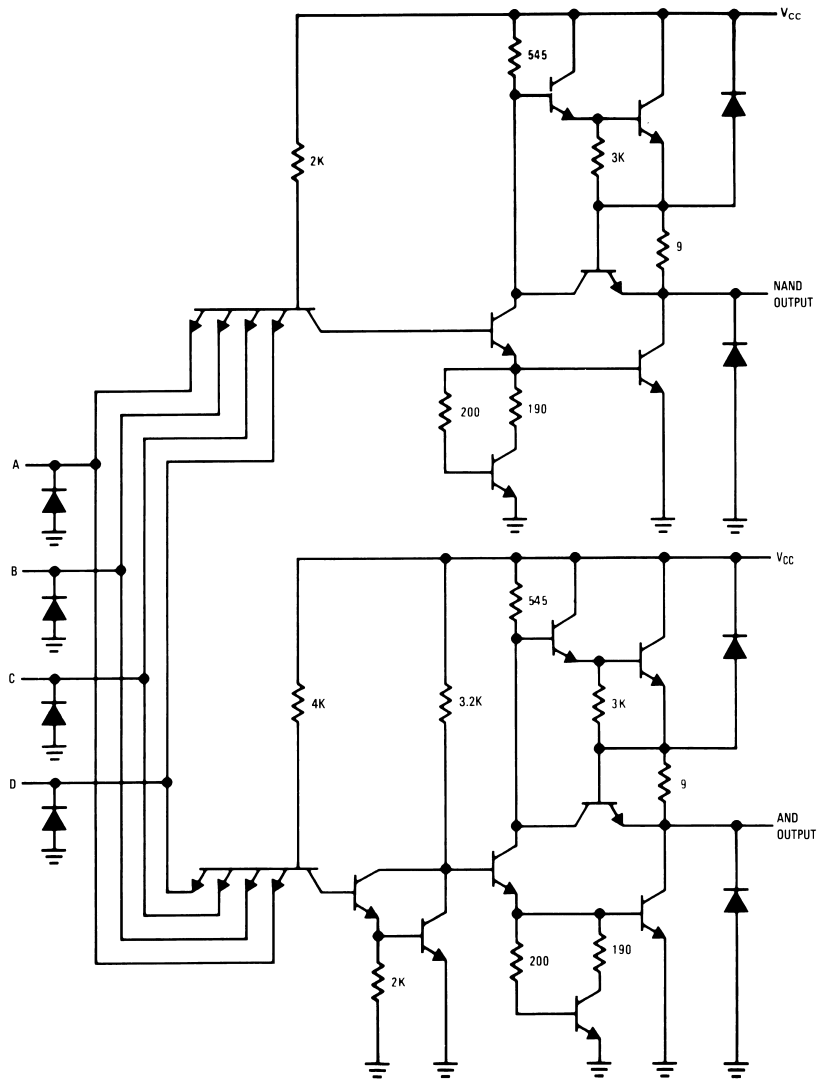

DS005799-1

*2 Per Package

Physical Dimensions inches (millimeters) unless otherwise noted

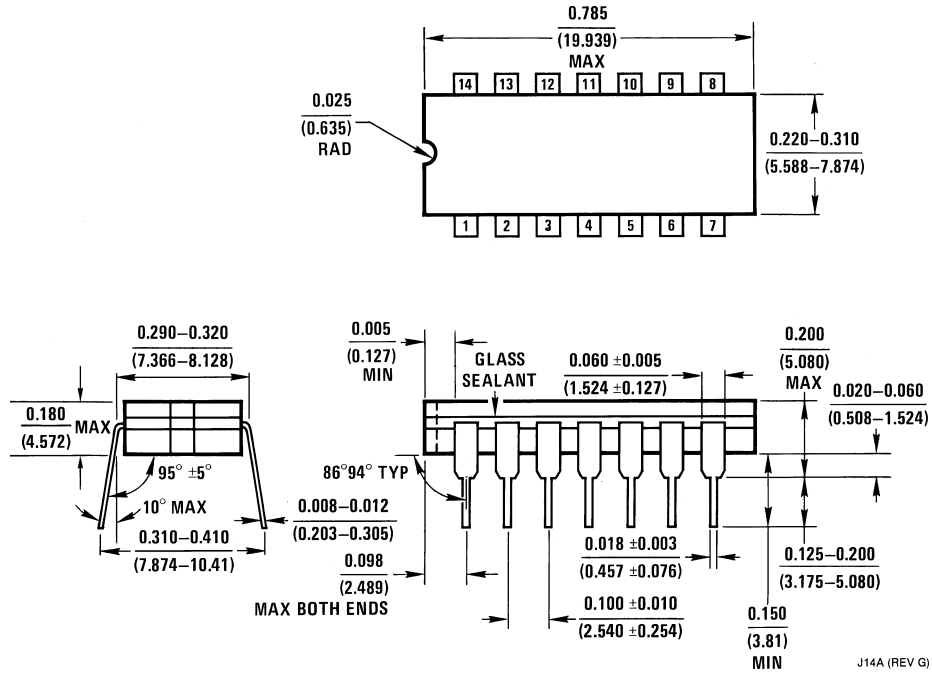

Ceramic Dual-In-Line Package (J)
Order Number DS7830J or DS8830J
NS Package Number J14A

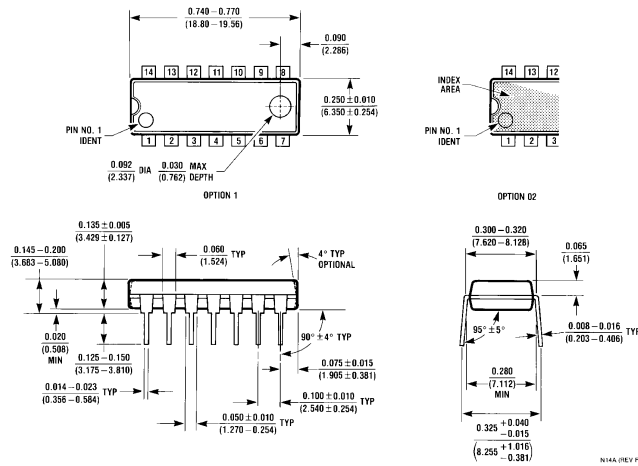

Molded Dual-In-Line Package (N)
Order Number DS8830N
NS Package Number N14A

Notes

LIFE SUPPORT POLICY

NATIONAL'S PRODUCTS ARE NOT AUTHORIZED FOR USE AS CRITICAL COMPONENTS IN LIFE SUPPORT DEVICES OR SYSTEMS WITHOUT THE EXPRESS WRITTEN APPROVAL OF THE PRESIDENT AND GENERAL COUNSEL OF NATIONAL SEMICONDUCTOR CORPORATION. As used herein:

1. Life support devices or systems are devices or systems which, (a) are intended for surgical implant into the body, or (b) support or sustain life, and whose failure to perform when properly used in accordance with instructions for use provided in the labeling, can be reasonably expected to result in a significant injury to the user.
2. A critical component is any component of a life support device or system whose failure to perform can be reasonably expected to cause the failure of the life support device or system, or to affect its safety or effectiveness.



National Semiconductor Corporation
Americas
Tel: 1-800-272-9959
Fax: 1-800-737-7018
Email: support@nsc.com

www.national.com

National Semiconductor Europe
Fax: +49 (0) 1 80-530 85 86
Email: europe.support@nsc.com
Deutsch Tel: +49 (0) 1 80-530 85 85
English Tel: +49 (0) 1 80-532 78 32
Français Tel: +49 (0) 1 80-532 93 58
Italiano Tel: +49 (0) 1 80-534 16 80

National Semiconductor Asia Pacific Customer Response Group
Tel: 65-2544466
Fax: 65-2504466
Email: sea.support@nsc.com

National Semiconductor Japan Ltd.
Tel: 81-3-5639-7560
Fax: 81-3-5639-7507

National does not assume any responsibility for use of any circuitry described, no circuit patent licenses are implied and National reserves the right at any time without notice to change said circuitry and specifications.