

## RS-423 Dual Programmable Slew Rate Line Driver

### General Description

The DS9636A is a TTL/CMOS compatible, dual, single ended line driver which has been specifically designed to satisfy the requirements of EIA Standard RS-423.

The DS9636A is suitable for use in digital data transmission systems where signal wave shaping is desired. The output slew rates are jointly controlled by a single external resistor connected between the wave shaping control lead (WS) and ground. This eliminates any need for external filtering of the output signals. Output voltage levels and slew rates are independent of power supply variations. Current-limiting is provided in both output states. The DS9636A is designed for nominal power supplies of  $\pm 12V$ .

Inputs are TTL compatible with input current loading low enough (1/10 UL) to be also compatible with CMOS logic. Clamp diodes are provided on the inputs to limit transients below ground.

### Features

- Programmable slew rate limiting
- Meets EIA Standard RS-423
- Commercial or extended temperature range
- Output short circuit protection
- TTL and CMOS compatible inputs

### Connection Diagram

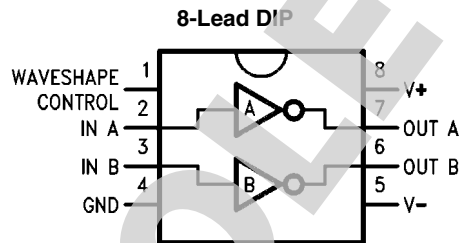

962001

Top View  
**Order Number DS9636ACN,**  
**See NS Package Number N08E**  
**For Complete Military Product Specifications,**  
**refer to the appropriate SMD or MDS.**  
**Order Number DS9636AJ/883**  
**See NS Package Number J08A**

## Absolute Maximum Ratings *(Note 1)*

If Military/Aerospace specified devices are required, please contact the National Semiconductor Sales Office/Distributors for availability and specifications.

Storage Temperature Range	
Ceramic DIP	-65°C to +175°C
Molded DIP	-65°C to +150°C
Lead Temperature	
Ceramic DIP (Soldering, 60 seconds)	300°C
Molded DIP (Soldering, 10 seconds)	265°C

Maximum Power Dissipation\* at 25°C *(Note 5)*

Cavity Package	1560 mW
Molded Package	1300 mW
V+ Lead Potential to Ground Lead	V- to +15V
V- Lead Potential to Ground Lead	+0.5V to -15V
V+ Lead Potential to V- Lead	0V to +30V
Output Potential to Ground Lead	±15V
Output Source Current	-150 mA
Output Sink Current	150 mA

## Recommended Operating Conditions

Characteristics	DS9636AM			DS9636AC			Units
	Min	Typ	Max	Min	Typ	Max	
Positive Supply Voltage (V+)	10.8	12	13.2	10.8	12	13.2	V
Negative Supply Voltage (V-)	-13.2	-12	-10.8	-13.2	-12	-10.8	V
Operating Temperature (T <sub>A</sub> )	-55	25	125	0	25	70	°C
Wave Shaping Resistance (R <sub>WS</sub> )	10		500	10		1000	kΩ

## Electrical Characteristics *(Note 2, Note 3)*

Over recommended operating temperature, supply voltage and wave shaping resistance ranges unless otherwise specified

Symbol	Parameter	Conditions	Min	Typ	Max	Units
V <sub>OH1</sub>	Output Voltage HIGH	R <sub>L</sub> to GND (R <sub>L</sub> = ∞)	5.0	5.6	6.0	V
V <sub>OH2</sub>		R <sub>L</sub> to GND (R <sub>L</sub> = 3.0 kΩ)	5.0	5.6	6.0	V
V <sub>OH3</sub>		R <sub>L</sub> to GND (R <sub>L</sub> = 450Ω)	4.0	5.5	6.0	V
V <sub>OL1</sub>	Output Voltage LOW	R <sub>L</sub> to GND (R <sub>L</sub> = ∞)	-6.0	-5.7	-5.0	V
V <sub>OL2</sub>		R <sub>L</sub> to GND (R <sub>L</sub> = 3.0 kΩ)	-6.0	-5.6	-5.0	V
V <sub>OL3</sub>		R <sub>L</sub> to GND (R <sub>L</sub> = 450Ω)	-6.0	-5.4	-4.0	V
R <sub>O</sub>	Output Resistance	450Ω ≤ R <sub>L</sub>		25	50	Ω
I <sub>OS+</sub>	Output Short Circuit Current <i>(Note 4)</i>	V <sub>O</sub> = 0V, V <sub>I</sub> = 0V	-150	-60	-15	mA
I <sub>OS-</sub>		V <sub>O</sub> = 0V, V <sub>I</sub> = 2.0V	15	60	150	mA
I <sub>CEX</sub>	Output Leakage Current	V <sub>O</sub> = ±6.0V, Power-Off	-100		+100	μA
V <sub>IH</sub>	Input Voltage HIGH		2.0			V
V <sub>IL</sub>	Input Voltage LOW				0.8	V
V <sub>IC</sub>	Input Clamp Diode Voltage	I <sub>I</sub> = 15 mA	-1.5	-1.1		V
I <sub>IL</sub>	Input Current LOW	V <sub>I</sub> = 0.4V	-80	-16		V
I <sub>IH</sub>	Input Current HIGH	V <sub>I</sub> = 2.4V		1.0	10	μA
		V <sub>I</sub> = 5.5V		10	100	
I+	Positive Supply Current	V <sub>CC</sub> = ±12V, R <sub>L</sub> = ∞, R <sub>WS</sub> = 100 kΩ, V <sub>I</sub> = 0V		13	18	mA
I-	Negative Supply Current	V <sub>CC</sub> = ±12V, R <sub>L</sub> = ∞, R <sub>WS</sub> = 100 kΩ, V <sub>I</sub> = 0V	-18	-13		mA

**Note 1:** "Absolute Maximum Ratings" are those values beyond which the safety of the device cannot be guaranteed. They are not meant to imply that the devices should be operated at these limits. The tables of "Electrical Characteristics" provide conditions for actual device operation.

**Note 2:** Unless otherwise specified Min/Max limits apply across the -55°C to +125°C temperature range for the DS9636AM and across the 0°C to +70°C range for the DS9636AC. All typicals are given for V<sub>CC</sub> = 5V and T<sub>A</sub> = 25°C.

**Note 3:** All currents into the device pins are positive; all currents out of the device pins are negative. All voltages are reference to ground unless otherwise specified.

**Note 4:** Only one output at a time should be shorted.

**Note 5:** Ratings apply to ambient temperature at 25°C. Above this temperature, derate J and N packages 10.4 mW/°C.

## Switching Characteristics

$V_{CC} = \pm 12V \pm 10\%$ ,  $T_A = 25^\circ C$ , see AC Test Circuit

Symbol	Parameter	Condition	Min	Typ	Max	Units
$t_r$	Rise Time	$R_{WS} = 10\text{ k}\Omega$	0.8	1.1	1.4	$\mu s$
		$R_{WS} = 100\text{ k}\Omega$	8.0	11	14	
		$R_{WS} = 500\text{ k}\Omega$	40	55	70	
		$R_{WS} = 1000\text{ k}\Omega$	80	110	140	
$t_f$	Fall Time	$R_{WS} = 10\text{ k}\Omega$	0.8	1.1	1.4	$\mu s$
		$R_{WS} = 100\text{ k}\Omega$	8.0	11	14	
		$R_{WS} = 500\text{ k}\Omega$	40	55	70	
		$R_{WS} = 1000\text{ k}\Omega$	80	110	140	

## Typical Performance Characteristics

Input/Output Transfer Characteristic vs Temperature

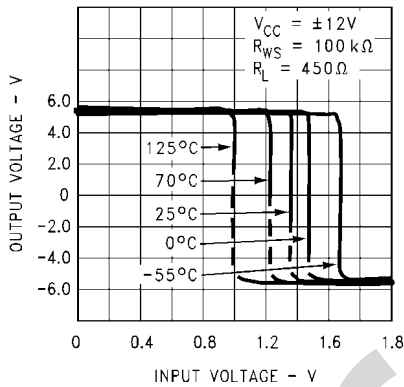

962007

Input Current vs Input Voltage

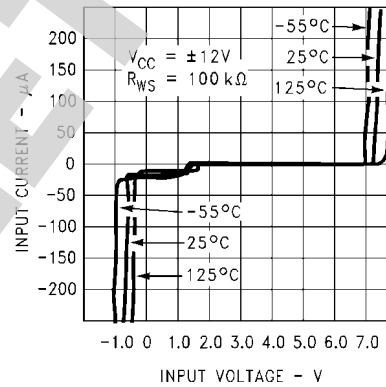

962008

Output Current vs Output Voltage (Power On)

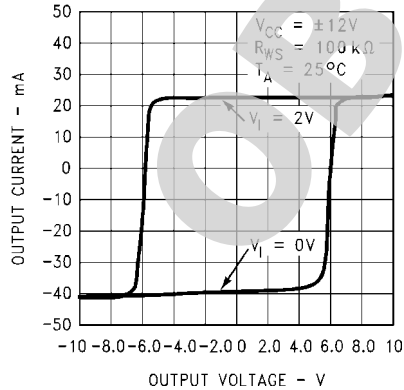

962009

Output Current vs Output Voltage (Power Off)

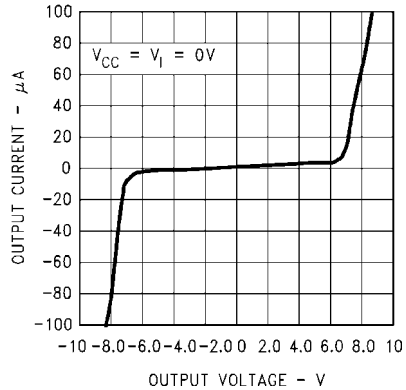

962010

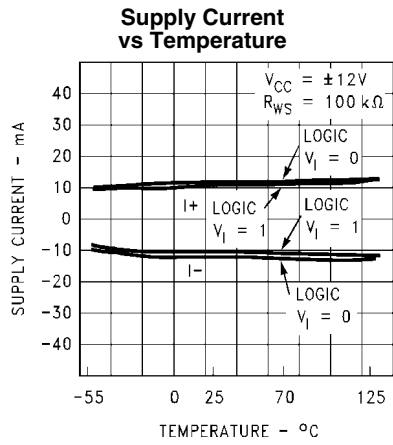

962011

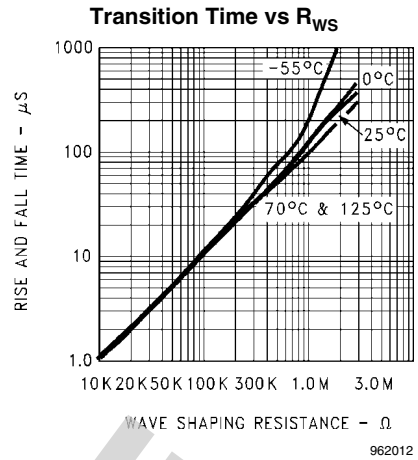

962012

## AC Test Circuit and Waveforms

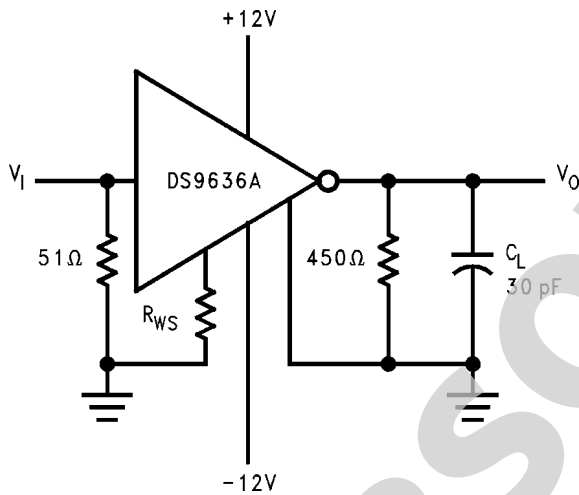

962004

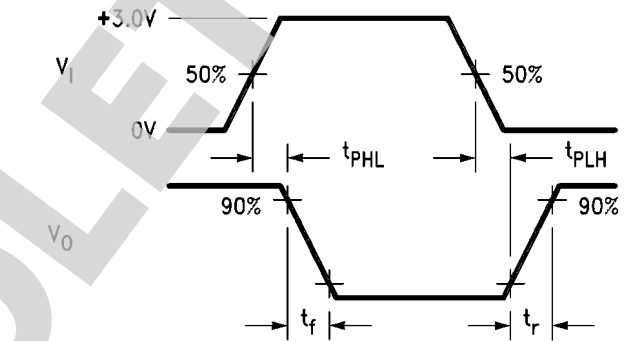

962005

$C_L$  includes jig and probe capacitance

$V_I$   
Amplitude: 3.0V  
Offset: 0V  
Pulse Width: 500  $\mu s$   
PRR: 1.0 kHz  
 $t_r = t_f \leq 10$  ns

## RS-423 System Application

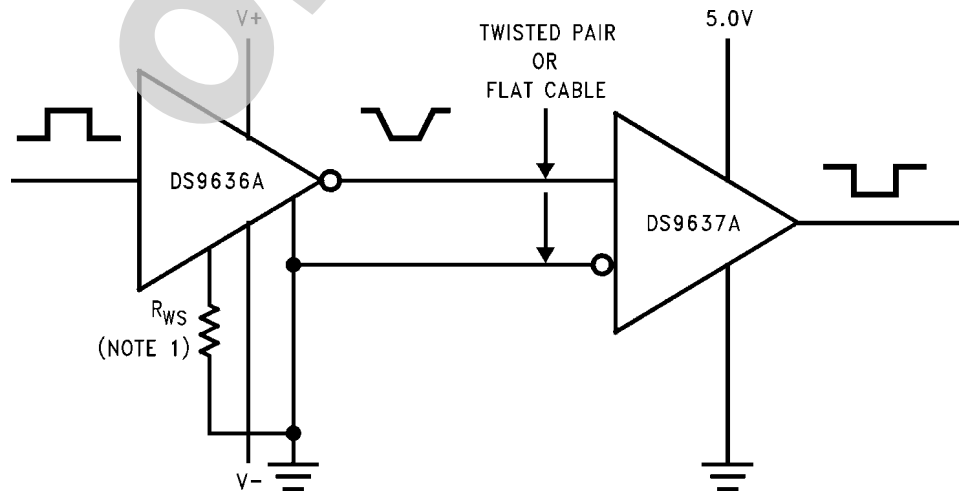

962006

**Physical Dimensions** inches (millimeters) unless otherwise noted

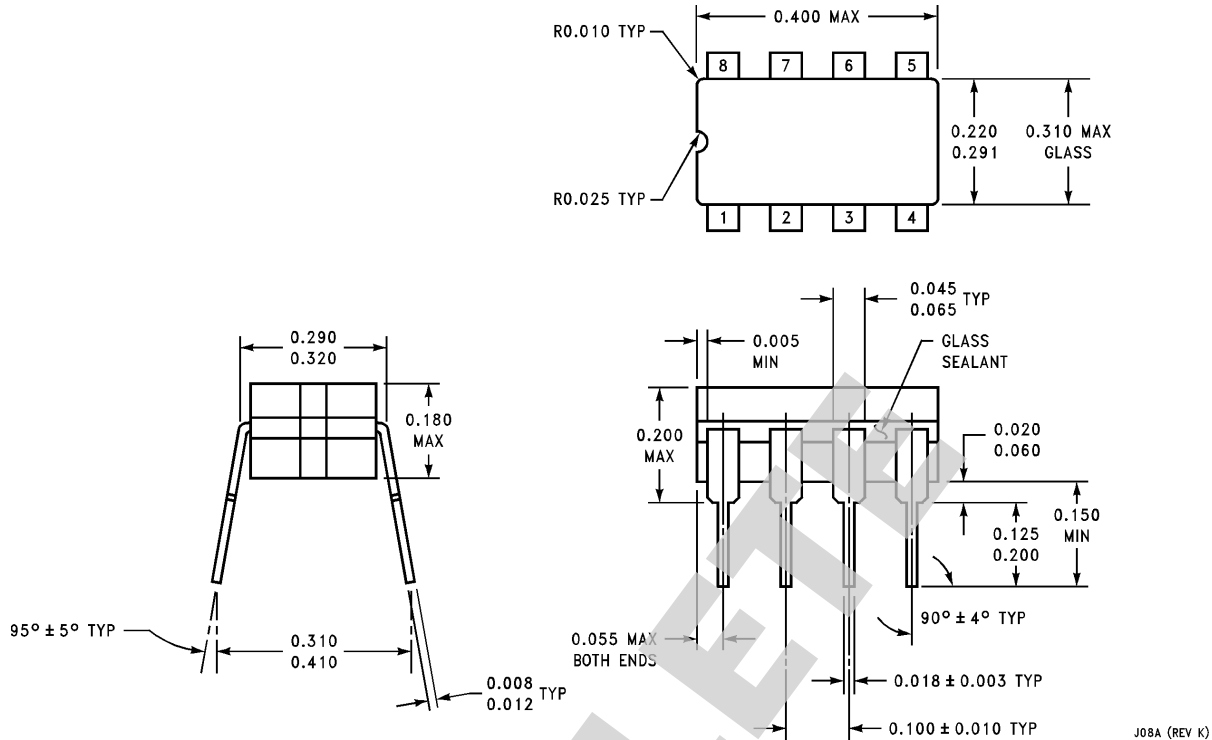

**Ceramic Dual-In-Line Package (J)**  
**Order Number DS9636AJ/883**  
**NS Package Number J08A**

J08A (REV K)

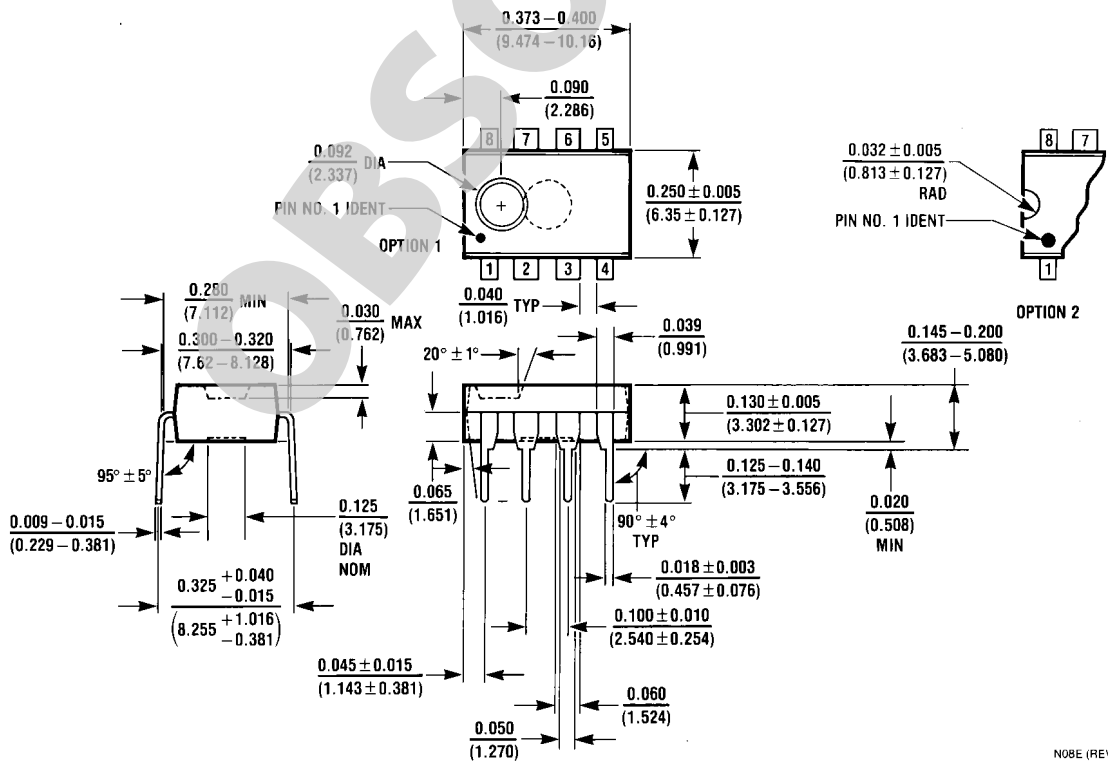

**Molded Dual-In-Line Package (N)**  
**Order Number DS9636ACN**  
**NS Package Number N08E**

N08E (REV F)

## Notes

For more National Semiconductor product information and proven design tools, visit the following Web sites at:

Products		Design Support	
Amplifiers	<a href="http://www.national.com/amplifiers">www.national.com/amplifiers</a>	WEBENCH® Tools	<a href="http://www.national.com/webench">www.national.com/webench</a>
Audio	<a href="http://www.national.com/audio">www.national.com/audio</a>	App Notes	<a href="http://www.national.com/appnotes">www.national.com/appnotes</a>
Clock and Timing	<a href="http://www.national.com/timing">www.national.com/timing</a>	Reference Designs	<a href="http://www.national.com/refdesigns">www.national.com/refdesigns</a>
Data Converters	<a href="http://www.national.com/adc">www.national.com/adc</a>	Samples	<a href="http://www.national.com/samples">www.national.com/samples</a>
Interface	<a href="http://www.national.com/interface">www.national.com/interface</a>	Eval Boards	<a href="http://www.national.com/evalboards">www.national.com/evalboards</a>
LVDS	<a href="http://www.national.com/lvds">www.national.com/lvds</a>	Packaging	<a href="http://www.national.com/packaging">www.national.com/packaging</a>
Power Management	<a href="http://www.national.com/power">www.national.com/power</a>	Green Compliance	<a href="http://www.national.com/quality/green">www.national.com/quality/green</a>
Switching Regulators	<a href="http://www.national.com/switchers">www.national.com/switchers</a>	Distributors	<a href="http://www.national.com/contacts">www.national.com/contacts</a>
LDOs	<a href="http://www.national.com/ldo">www.national.com/ldo</a>	Quality and Reliability	<a href="http://www.national.com/quality">www.national.com/quality</a>
LED Lighting	<a href="http://www.national.com/led">www.national.com/led</a>	Feedback/Support	<a href="http://www.national.com/feedback">www.national.com/feedback</a>
Voltage Reference	<a href="http://www.national.com/vref">www.national.com/vref</a>	Design Made Easy	<a href="http://www.national.com/easy">www.national.com/easy</a>
PowerWise® Solutions	<a href="http://www.national.com/powerwise">www.national.com/powerwise</a>	Solutions	<a href="http://www.national.com/solutions">www.national.com/solutions</a>
Serial Digital Interface (SDI)	<a href="http://www.national.com/sdi">www.national.com/sdi</a>	Mil/Aero	<a href="http://www.national.com/milaero">www.national.com/milaero</a>
Temperature Sensors	<a href="http://www.national.com/tempensors">www.national.com/tempensors</a>	SolarMagic™	<a href="http://www.national.com/solarmagic">www.national.com/solarmagic</a>
Wireless (PLL/VCO)	<a href="http://www.national.com/wireless">www.national.com/wireless</a>	PowerWise® Design University	<a href="http://www.national.com/training">www.national.com/training</a>

THE CONTENTS OF THIS DOCUMENT ARE PROVIDED IN CONNECTION WITH NATIONAL SEMICONDUCTOR CORPORATION ("NATIONAL") PRODUCTS. NATIONAL MAKES NO REPRESENTATIONS OR WARRANTIES WITH RESPECT TO THE ACCURACY OR COMPLETENESS OF THE CONTENTS OF THIS PUBLICATION AND RESERVES THE RIGHT TO MAKE CHANGES TO SPECIFICATIONS AND PRODUCT DESCRIPTIONS AT ANY TIME WITHOUT NOTICE. NO LICENSE, WHETHER EXPRESS, IMPLIED, ARISING BY ESTOPPEL OR OTHERWISE, TO ANY INTELLECTUAL PROPERTY RIGHTS IS GRANTED BY THIS DOCUMENT.

TESTING AND OTHER QUALITY CONTROLS ARE USED TO THE EXTENT NATIONAL DEEMS NECESSARY TO SUPPORT NATIONAL'S PRODUCT WARRANTY. EXCEPT WHERE MANDATED BY GOVERNMENT REQUIREMENTS, TESTING OF ALL PARAMETERS OF EACH PRODUCT IS NOT NECESSARILY PERFORMED. NATIONAL ASSUMES NO LIABILITY FOR APPLICATIONS ASSISTANCE OR BUYER PRODUCT DESIGN. BUYERS ARE RESPONSIBLE FOR THEIR PRODUCTS AND APPLICATIONS USING NATIONAL COMPONENTS. PRIOR TO USING OR DISTRIBUTING ANY PRODUCTS THAT INCLUDE NATIONAL COMPONENTS, BUYERS SHOULD PROVIDE ADEQUATE DESIGN, TESTING AND OPERATING SAFEGUARDS.

EXCEPT AS PROVIDED IN NATIONAL'S TERMS AND CONDITIONS OF SALE FOR SUCH PRODUCTS, NATIONAL ASSUMES NO LIABILITY WHATSOEVER, AND NATIONAL DISCLAIMS ANY EXPRESS OR IMPLIED WARRANTY RELATING TO THE SALE AND/OR USE OF NATIONAL PRODUCTS INCLUDING LIABILITY OR WARRANTIES RELATING TO FITNESS FOR A PARTICULAR PURPOSE, MERCHANTABILITY, OR INFRINGEMENT OF ANY PATENT, COPYRIGHT OR OTHER INTELLECTUAL PROPERTY RIGHT.

### LIFE SUPPORT POLICY

**NATIONAL'S PRODUCTS ARE NOT AUTHORIZED FOR USE AS CRITICAL COMPONENTS IN LIFE SUPPORT DEVICES OR SYSTEMS WITHOUT THE EXPRESS PRIOR WRITTEN APPROVAL OF THE CHIEF EXECUTIVE OFFICER AND GENERAL COUNSEL OF NATIONAL SEMICONDUCTOR CORPORATION.** As used herein:

Life support devices or systems are devices which (a) are intended for surgical implant into the body, or (b) support or sustain life and whose failure to perform when properly used in accordance with instructions for use provided in the labeling can be reasonably expected to result in a significant injury to the user. A critical component is any component in a life support device or system whose failure to perform can be reasonably expected to cause the failure of the life support device or system or to affect its safety or effectiveness.

National Semiconductor and the National Semiconductor logo are registered trademarks of National Semiconductor Corporation. All other brand or product names may be trademarks or registered trademarks of their respective holders.

Copyright© 2009 National Semiconductor Corporation

For the most current product information visit us at [www.national.com](http://www.national.com)

 **National Semiconductor Americas Technical Support Center**  
 Email: [support@nsc.com](mailto:support@nsc.com)  
 Tel: 1-800-272-9959

**National Semiconductor Europe Technical Support Center**  
 Email: [europe.support@nsc.com](mailto:europe.support@nsc.com)

**National Semiconductor Asia Pacific Technical Support Center**  
 Email: [ap.support@nsc.com](mailto:ap.support@nsc.com)

**National Semiconductor Japan Technical Support Center**  
 Email: [jpn.feedback@nsc.com](mailto:jpn.feedback@nsc.com)