



# M41ST85W

## 3.0/3.3 V I<sup>2</sup>C combination serial RTC, NVRAM supervisor and microprocessor supervisor

### Features

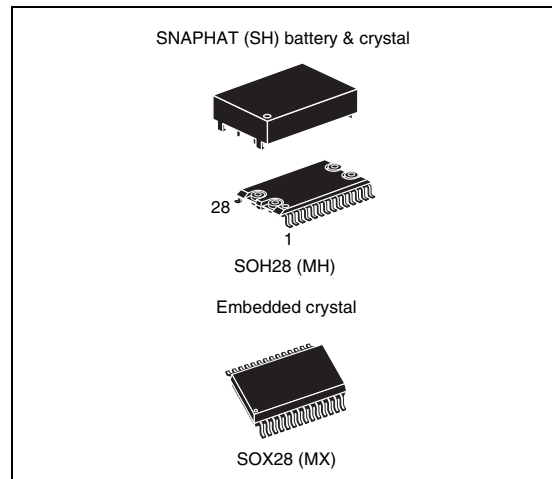
- Automatic battery switchover and WRITE protect for:
  - Internal serial RTC and
  - External low power SRAM (LPSRAM)
- 400 kHz I<sup>2</sup>C serial interface
- 3.0/3.3 V operating voltage
  - V<sub>CC</sub> = 2.7 to 3.6 V
- Ultralow battery supply current of 500 nA (max)
- RoHS compliant
  - Lead-free second level interconnect

### Serial RTC features

- 400 kHz I<sup>2</sup>C
- 44 bytes of general purpose NVRAM
- Counters for:
  - Seconds, minutes, hours, day, date, month, and year
  - Century
  - Tenths/hundredths of seconds
  - Clock calibration register allows compensation for crystal variations over temperature
- Programmable alarm with repeat modes
  - Functions in battery back-up mode
- Power-down timestamp (HT bit)
- 2.5 to 5.5 V oscillator operating voltage

### Microprocessor supervisor features

- Programmable watchdog
  - 62.5 ms to 128 s time-out period
- Early power-fail warning circuit (PFI/PFO) with 1.25 V precision reference



- Power-on reset/low voltage detect
  - Open drain reset output
  - Reset voltage, V<sub>PFD</sub> = 2.60 V (nom)
  - Two reset input pins
  - Watchdog can be steered to reset output

### NVRAM supervisor features

- Non-volatizes external LPSRAM
  - Automatically switches to back-up battery and deselected (write-protects) external LPSRAM via chip-enable gate
  - Power-fail deselect (write protect) voltage, V<sub>PFD</sub> = 2.60 V (nom)
  - Switchover, V<sub>SO</sub> = 2.50 V (nom)
- Battery monitor (battery low flag)

### Other features

- Programmable squarewave generator (1 Hz to 32 KHz)
- –40°C to +85°C operation
- Package options:
  - 28-lead SNAPHAT<sup>®</sup> IC (SOH28) SNAPHAT battery/crystal top to be ordered separately
  - 28-lead embedded crystal SOIC (SOX28)

# Contents

<b>1</b>	<b>Description</b> .....	<b>6</b>
<b>2</b>	<b>Operating modes</b> .....	<b>12</b>
2.1	2-wire bus characteristics .....	12
2.1.1	Bus not busy .....	13
2.1.2	Start data transfer .....	13
2.1.3	Stop data transfer .....	13
2.1.4	Data valid .....	13
2.1.5	Acknowledge .....	13
2.2	Read mode .....	15
2.3	Write mode .....	17
2.4	Data retention mode .....	17
<b>3</b>	<b>Clock operation</b> .....	<b>19</b>
3.1	Power-down time-stamp .....	19
3.2	TIMEKEEPER® registers .....	19
3.3	Calibrating the clock .....	21
3.4	Setting alarm clock registers .....	22
3.5	Watchdog timer .....	24
3.6	Square wave output .....	25
3.7	Power-on reset .....	25
3.8	Reset inputs ( $\overline{\text{RSTIN1}}$ & $\overline{\text{RSTIN2}}$ ) .....	26
3.9	Power-fail input/output .....	26
3.10	Century bit .....	27
3.11	Output driver pin .....	27
3.12	Battery low warning .....	27
3.13	$t_{\text{rec}}$ bit .....	28
3.14	Initial power-on defaults .....	28
<b>4</b>	<b>Maximum ratings</b> .....	<b>29</b>
<b>5</b>	<b>DC and AC parameters</b> .....	<b>30</b>

---

<b>6</b>	<b>Package mechanical data</b> .....	<b>34</b>
<b>7</b>	<b>Part numbering</b> .....	<b>38</b>
<b>8</b>	<b>Environmental information</b> .....	<b>39</b>
<b>9</b>	<b>Revision history</b> .....	<b>40</b>

## List of tables

Table 1.	Signal names . . . . .	8
Table 2.	TIMEKEEPER <sup>®</sup> register map . . . . .	20
Table 3.	Alarm repeat modes . . . . .	23
Table 4.	Square wave output frequency . . . . .	25
Table 5.	Reset AC characteristics . . . . .	26
Table 6.	t <sub>rec</sub> definitions . . . . .	28
Table 7.	Default values . . . . .	28
Table 8.	Absolute maximum ratings . . . . .	29
Table 9.	DC and AC measurement conditions . . . . .	30
Table 10.	Capacitance . . . . .	30
Table 11.	DC characteristics . . . . .	31
Table 12.	AC characteristics . . . . .	32
Table 13.	Power down/up AC characteristics . . . . .	33
Table 14.	SOH28 – 28-lead plastic small outline, battery SNAPHAT <sup>®</sup> , package mechanical data . . . . .	34
Table 15.	SH – 4-pin SNAPHAT <sup>®</sup> housing for 48 mAh battery & crystal, mechanical data . . . . .	35
Table 16.	SH – 4-pin SNAPHAT <sup>®</sup> housing for 120 mAh battery & crystal, mechanical data . . . . .	36
Table 17.	SOX28 – 28-lead plastic small outline, 300 mils, embedded crystal, mechanical data . . . . .	37
Table 18.	Ordering information scheme . . . . .	38
Table 19.	SNAPHAT <sup>®</sup> battery/crystal table . . . . .	38
Table 20.	Document revision history . . . . .	40

## List of figures

Figure 1.	Logic diagram . . . . .	7
Figure 2.	28-pin SOIC connections . . . . .	8
Figure 3.	28-pin, 300 mil SOIC (MX) connections . . . . .	9
Figure 4.	Block diagram . . . . .	10
Figure 5.	Hardware hookup . . . . .	11
Figure 6.	Serial bus data transfer sequence . . . . .	14
Figure 7.	Acknowledgement sequence . . . . .	14
Figure 8.	Write cycle timing: RTC & external SRAM control signals . . . . .	14
Figure 9.	Slave address location . . . . .	15
Figure 10.	Read mode sequence. . . . .	16
Figure 11.	Alternate read mode sequence. . . . .	16
Figure 12.	Write mode sequence. . . . .	17
Figure 13.	Crystal accuracy across temperature . . . . .	22
Figure 14.	Calibration waveform . . . . .	22
Figure 15.	Alarm interrupt reset waveform. . . . .	23
Figure 16.	Backup mode alarm waveform . . . . .	24
Figure 17.	$\overline{RSTIN1}$ & $\overline{RSTIN2}$ timing waveforms . . . . .	26
Figure 18.	AC testing input/output waveforms . . . . .	30
Figure 19.	Bus timing requirements sequence . . . . .	32
Figure 20.	Power down/up mode AC waveforms. . . . .	33
Figure 21.	SOH28 – 28-lead plastic small outline, battery SNAPHAT <sup>®</sup> , package outline . . . . .	34
Figure 22.	SH – 4-pin SNAPHAT <sup>®</sup> housing for 48 mAh battery & crystal, package outline. . . . .	35
Figure 23.	SH – 4-pin SNAPHAT <sup>®</sup> housing for 120 mAh battery & crystal, package outline. . . . .	36
Figure 24.	SOX28 – 28-lead plastic small outline, 300 mils, embedded crystal, package outline . . . . .	37
Figure 25.	Recycling symbols . . . . .	39

# 1 Description

The M41ST85W is a combination serial real-time clock, microprocessor supervisor, and NVRAM supervisor. It is built in a low power CMOS SRAM process and has a 64-byte memory space with 44 bytes of NVRAM and 20 memory-mapped RTC registers (see [Table 2 on page 20](#)). The RTC registers are configured in binary coded decimal (BCD) format.

The M41ST85W combines a 400 kHz I<sup>2</sup>C serial RTC with an automatic backup battery switchover circuit for powering an external LPSRAM as well as the internal RTC. When power begins to fail, the switchover automatically connects to the backup battery to keep the RTC and external LPSRAM alive in the absence of system power. Access to the LPSRAM is also cut off via a chip-enable gate function, thereby write-protecting the memory. A programmable watchdog and power-on reset/low voltage detect function are the key elements in the microprocessor supervisor section.

The real-time clock includes a built-in 32.768 kHz oscillator (crystal-controlled), which provides the time base for the timekeeping and calendar functions. Eight of the 20 clock registers provide the basic clock/calendar functions while the other 12 bytes provide status/control for the alarm, watchdog, and squarewave functions.

RTC addresses and data are transferred serially via the two-line, bidirectional I<sup>2</sup>C interface. The built-in address register is incremented automatically after each WRITE or READ data byte.

The M41ST85W has a built-in power sense circuit which detects power failures and automatically switches to the backup battery when a power failure occurs. During an outage, the power to sustain the SRAM and clock operations is typically supplied by a small lithium button-cell battery as is the case when using the SNAPHAT<sup>®</sup> package option.

Functions available to the user include a non-volatile, time-of-day clock/calendar, alarm interrupts, watchdog timer, and programmable squarewave generator. Other features include a power-on reset as well as two additional debounce reset inputs (RSTIN1 and RSTIN2) which can also generate an output reset (RST).

The eight registers for basic clock/calendar functions contain the century, year, month, date, day, hour, minute, second, and tenths/hundredths of a second in 24-hour BCD format. Corrections for 28, 29 (leap year - valid until year 2100), 30 and 31 day months are made automatically.

The M41ST85W is offered in two 28-lead SOIC packages. The 300 mil SOH28 SNAPHAT<sup>®</sup> IC package mates with ST's SNAPHAT battery/crystal top (ordered separately). SNAPHAT battery options include 48 mAh and 120 mAh. ST's 300 mil SOX28 embedded crystal IC includes the 32 KHz crystal and is perfect for applications where a low profile is a must.

The SOH28 SNAPHAT SOIC includes sockets with gold plated contacts at both ends for direct connection to the SNAPHAT top. The SNAPHAT battery/crystal top is inserted atop the IC package after the completion of the surface mount assembly process which avoids potential battery and crystal damage due to the high temperatures required for device surface-mounting. The unique design allows the battery to be replaced, thus extending the life of the RTC and NVRAM indefinitely.

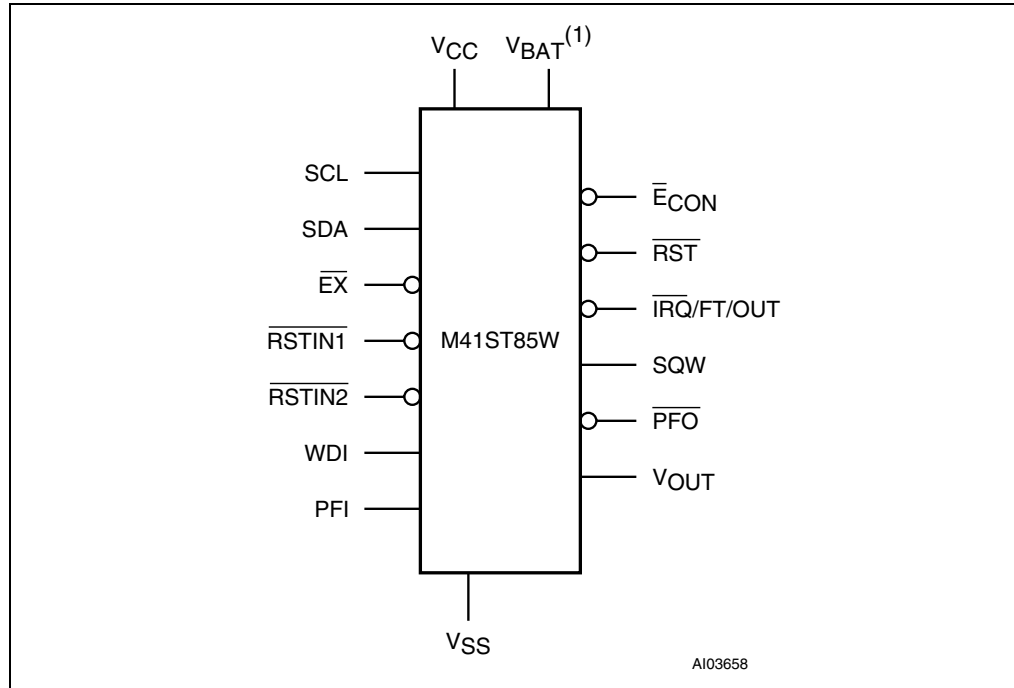
The SNAPHAT top is keyed to prevent reverse insertion. The SNAPHAT IC and SNAPHAT tops are shipped separately. The ICs are available in plastic anti-static tubes or in tape & reel form. The SNAPHAT tops are shipped in plastic anti-static tubes. The part numbers are

M4T28-BR12SH1 (48 mAh) and M4T32-BR12SH1 (120 mAh). For the extended temperature requirement, the 120 mAh M4T32-BR12SH6 is available. For more information, see [Table 19 on page 38](#).

**Caution:** Do not place the SNAPHAT<sup>®</sup> battery/crystal top in conductive foam, as this will drain the lithium button-cell battery.

The 300 mil SOX embedded crystal SOIC typically requires a user-supplied battery for non-volatile operation. Capacitor backup can also be implemented with this package.

**Figure 1. Logic diagram**



1. For 28-pin, 300 mil embedded crystal SOIC only.

**Table 1. Signal names**

$\overline{ECON}$	Conditioned chip enable output
EX	External chip enable
$\overline{IRQ/FT/OUT}$	Interrupt/frequency test/out output (open drain)
PFI	Power fail input
$\overline{PFO}$	Power fail output
$\overline{RST}$	Reset output (open drain)
$\overline{RSTIN1}$	Reset 1 Input
$\overline{RSTIN2}$	Reset 2 Input
SCL	Serial clock input
SDA	Serial data input/output
SQW	Square wave output
WDI	Watchdog input
V <sub>CC</sub>	Supply voltage
V <sub>OUT</sub>	Voltage output
V <sub>SS</sub>	Ground
V <sub>BAT</sub> <sup>(1)</sup>	Battery supply voltage
NC	No connect
NF	No function

1. For 28-pin, 300 mil embedded crystal SOIC only.

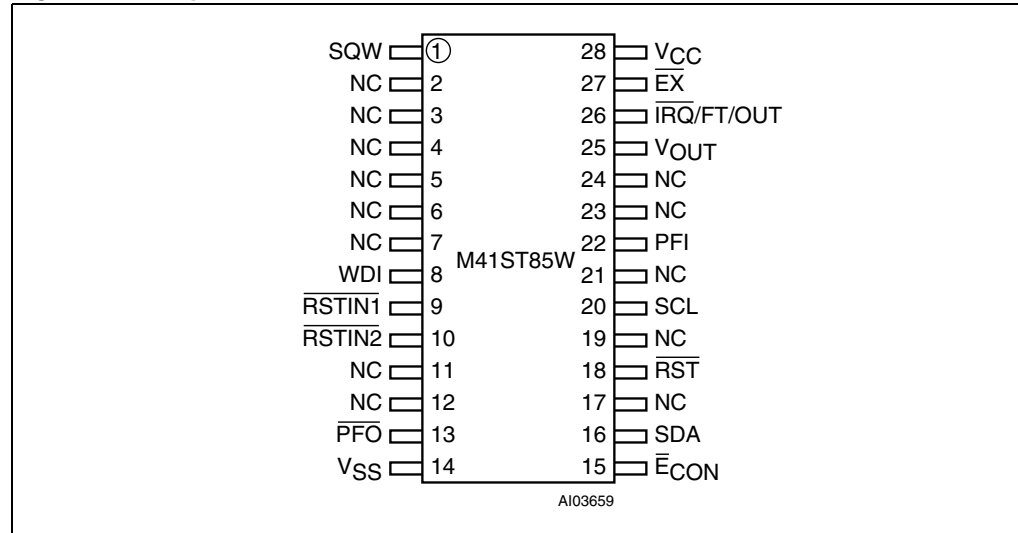
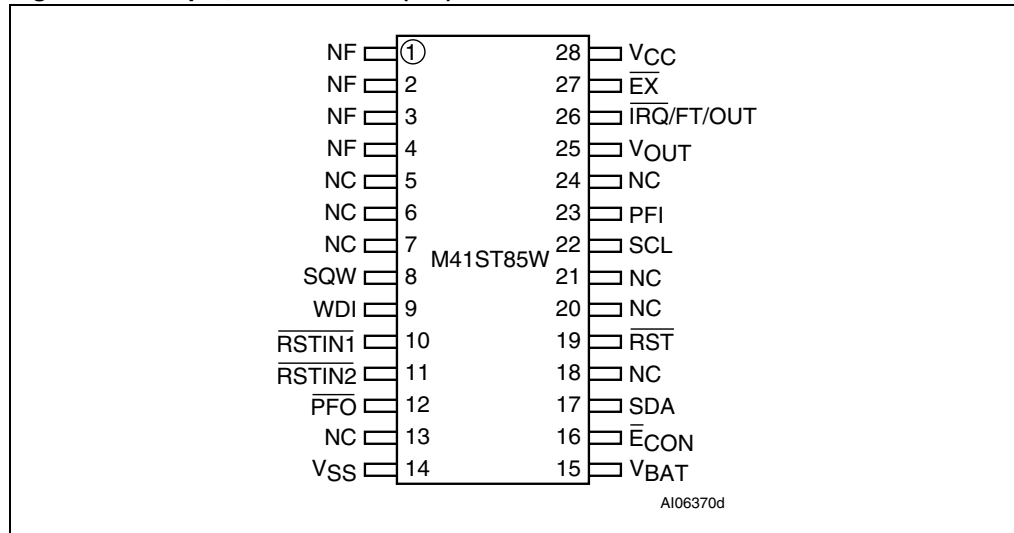
**Figure 2. 28-pin SOIC connections**

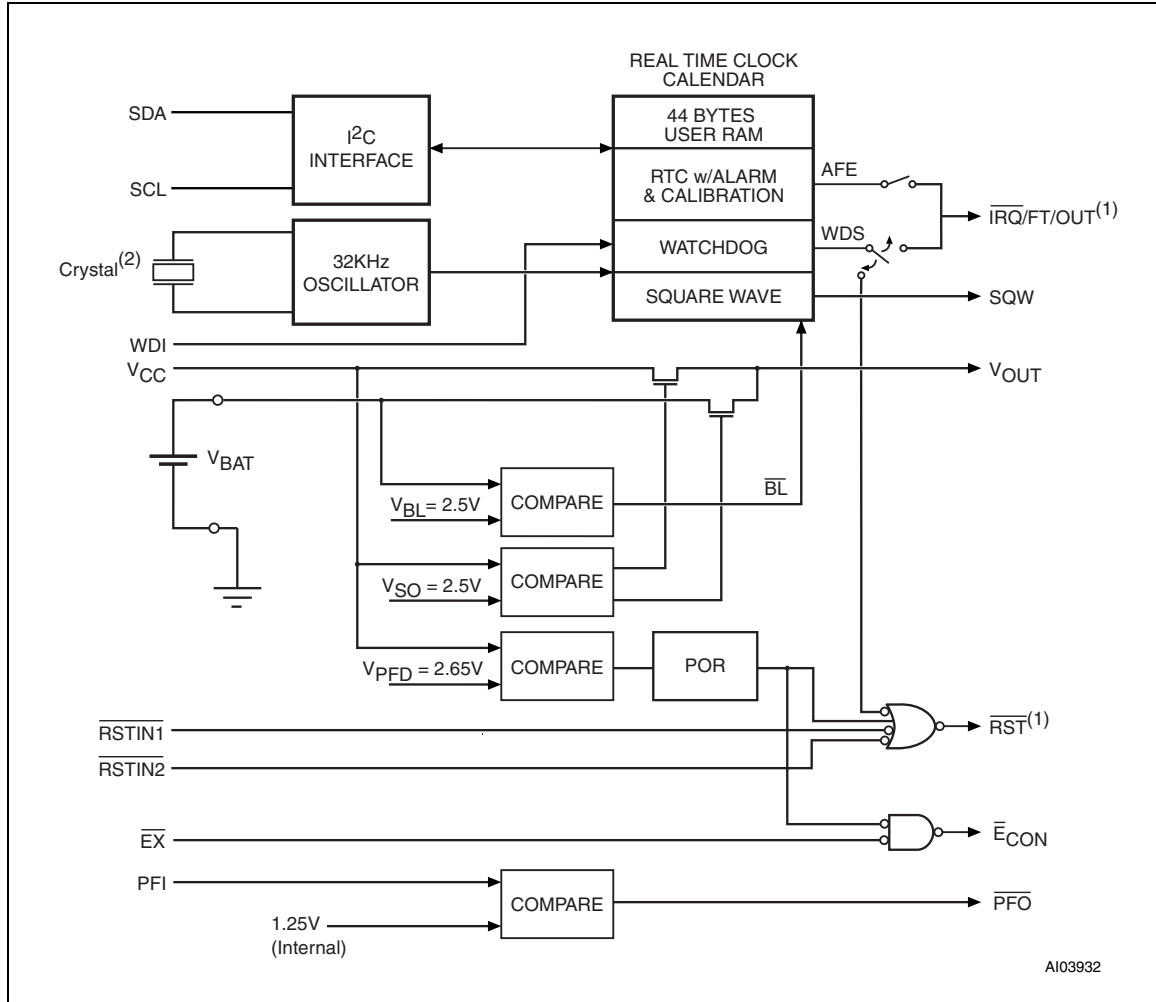


Figure 3. 28-pin, 300 mil SOIC (MX) connections



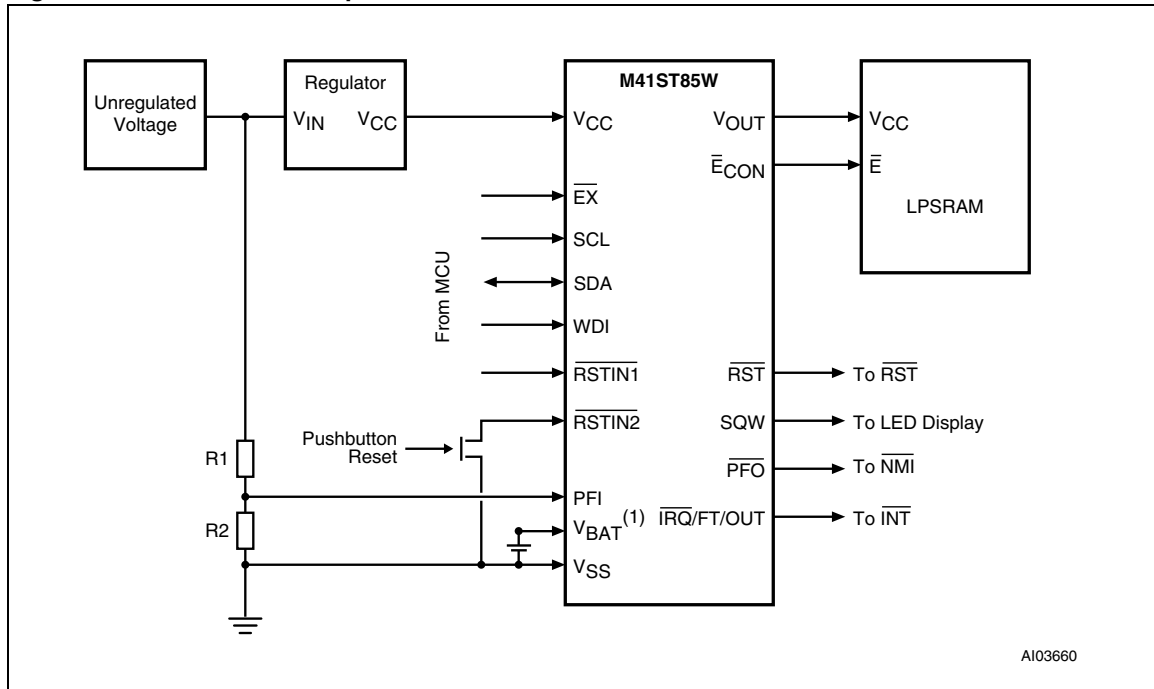
**Note:** No function (NF) pins should be tied to V<sub>SS</sub>. Pins 1, 2, 3, and 4 are internally shorted together.

Figure 4. Block diagram



1. Open drain output.
2. Crystal integrated into SOIC package for MX package option.

Figure 5. Hardware hookup



1. Required for embedded crystal (MX) package only.

## 2 Operating modes

The M41ST85W clock operates as a slave device on the serial bus. Access is obtained by implementing a start condition followed by the correct slave address (D0h). The 64 bytes contained in the device can then be accessed sequentially in the following order:

1. Tenths/hundredths of a second register
2. Seconds register
3. Minutes register
4. Century/hours register
5. Day register
6. Date register
7. Month register
8. Year register
9. Control register
10. Watchdog register
- 11 - 16. Alarm registers
- 17 - 19. Reserved
20. Square wave register
- 21 - 64. User RAM

The M41ST85W clock continually monitors  $V_{CC}$  for an out-of-tolerance condition. Should  $V_{CC}$  fall below  $V_{PFD}$ , the device terminates an access in progress and resets the device address counter. Inputs to the device will not be recognized at this time to prevent erroneous data from being written to the device from a an out-of-tolerance system. When  $V_{CC}$  falls below  $V_{SO}$ , the device automatically switches over to the battery and powers down into an ultralow current mode of operation to conserve battery life. As system power returns and  $V_{CC}$  rises above  $V_{SO}$ , the battery is disconnected, and the power supply is switched to external  $V_{CC}$ .

Write protection continues until  $V_{CC}$  reaches  $V_{PFD}(\text{min})$  plus  $t_{rec}(\text{min})$ .

For more information on battery storage life refer to application note AN1012.

### 2.1 2-wire bus characteristics

The bus is intended for communication between different ICs. It consists of two lines: a bi-directional data signal (SDA) and a clock signal (SCL). Both the SDA and SCL lines must be connected to a positive supply voltage via a pull-up resistor.

The following protocol has been defined:

- Data transfer may be initiated only when the bus is not busy.
- During data transfer, the data line must remain stable whenever the clock line is high.
- Changes in the data line, while the clock line is high, will be interpreted as control signals.

Accordingly, the following bus conditions have been defined:

### 2.1.1 **Bus not busy**

Both data and clock lines remain high.

### 2.1.2 **Start data transfer**

A change in the state of the data line, from high to low, while the clock is high, defines the START condition.

### 2.1.3 **Stop data transfer**

A change in the state of the data line, from low to high, while the clock is high, defines the STOP condition.

### 2.1.4 **Data valid**

The state of the data line represents valid data when after a start condition, the data line is stable for the duration of the high period of the clock signal. The data on the line may be changed during the low period of the clock signal. There is one clock pulse per bit of data.

Each data transfer is initiated with a start condition and terminated with a stop condition. The number of data bytes transferred between the start and stop conditions is not limited. The information is transmitted byte-wide and each receiver acknowledges with a ninth bit.

By definition a device that gives out a message is called “transmitter,” the receiving device that gets the message is called “receiver.” The device that controls the message is called “master.” The devices that are controlled by the master are called “slaves.”

### 2.1.5 **Acknowledge**

Each byte of eight bits is followed by one acknowledge bit. This acknowledge bit is a low level put on the bus by the receiver whereas the master generates an extra acknowledge related clock pulse. A slave receiver which is addressed is obliged to generate an acknowledge after the reception of each byte that has been clocked out of the slave transmitter.

The device that acknowledges has to pull down the SDA line during the acknowledge clock pulse in such a way that the SDA line is a stable low during the high period of the acknowledge related clock pulse. Of course, setup and hold times must be taken into account. A master receiver must signal an end of data to the slave transmitter by not generating an acknowledge on the last byte that has been clocked out of the slave. In this case the transmitter must leave the data line high to enable the master to generate the STOP condition.

Figure 6. Serial bus data transfer sequence

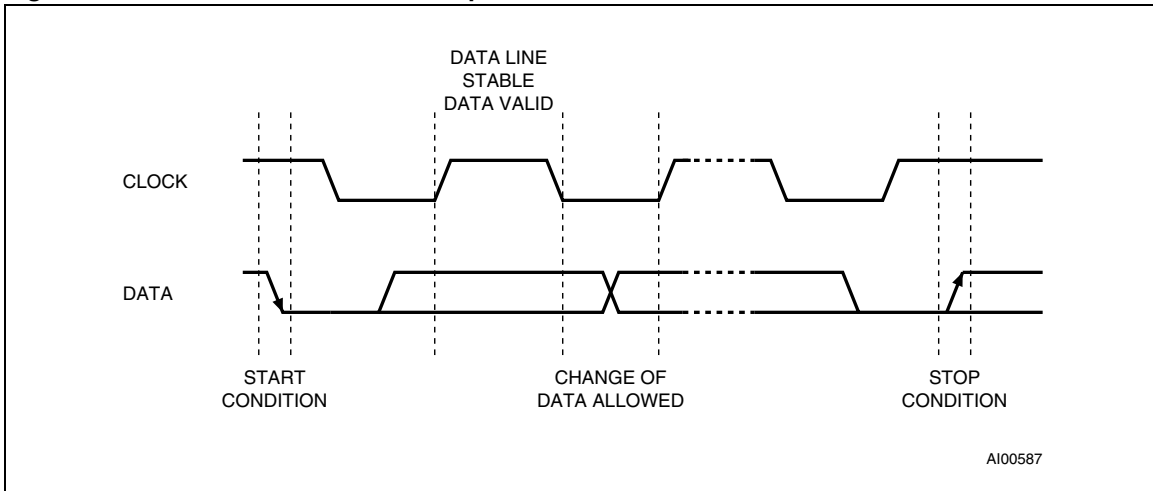


Figure 7. Acknowledgement sequence

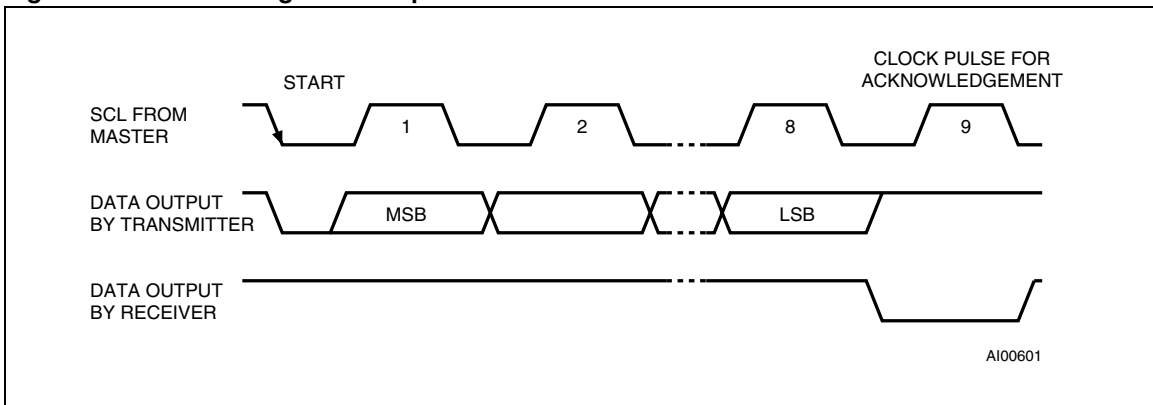
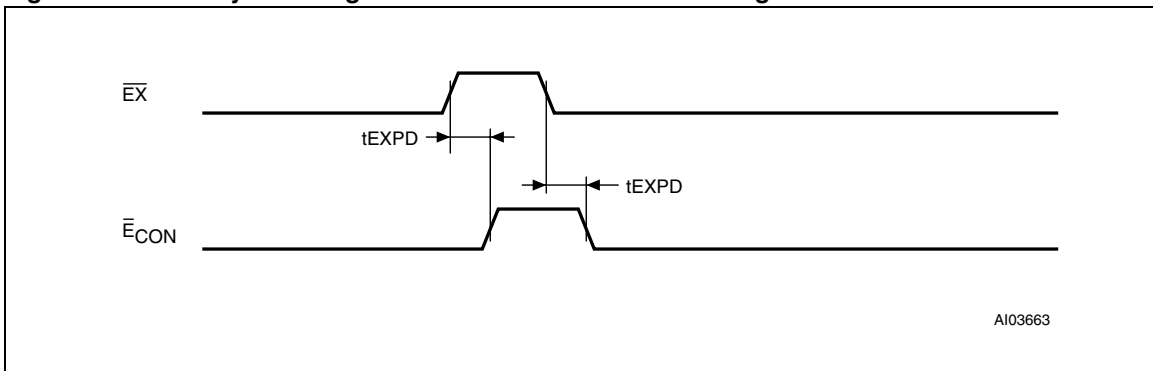


Figure 8. Write cycle timing: RTC & external SRAM control signals



## 2.2 Read mode

In this mode the master reads the M41ST85W slave after setting the slave address (see [Figure 9](#)). Following the WRITE mode control bit ( $R/\overline{W}=0$ ) and the acknowledge bit, the word address 'An' is written to the on-chip address pointer. Next the START condition and slave address are repeated followed by the READ mode control bit ( $R/\overline{W}=1$ ). At this point the master transmitter becomes the master receiver.

The data byte which was addressed will be transmitted and the master receiver will send an acknowledge bit to the slave transmitter (see [Figure 10 on page 16](#)). The address pointer is only incremented on reception of an acknowledge clock. The M41ST85W slave transmitter will now place the data byte at address An+1 on the bus, the master receiver reads and acknowledges the new byte and the address pointer is incremented to An+2.

This cycle of reading consecutive addresses will continue until the master receiver sends a STOP condition to the slave transmitter.

The system-to-user transfer of clock data will be halted whenever the address being read is a clock address (00h to 07h). The update will resume either due to a stop condition or when the pointer increments to a non-clock or RAM address.

*Note: This is true both in READ mode and WRITE mode.*

An alternate READ mode may also be implemented whereby the master reads the M41ST85W slave without first writing to the (volatile) address pointer. The first address that is read is the last one stored in the pointer (see [Figure 11 on page 16](#)).

**Figure 9. Slave address location**

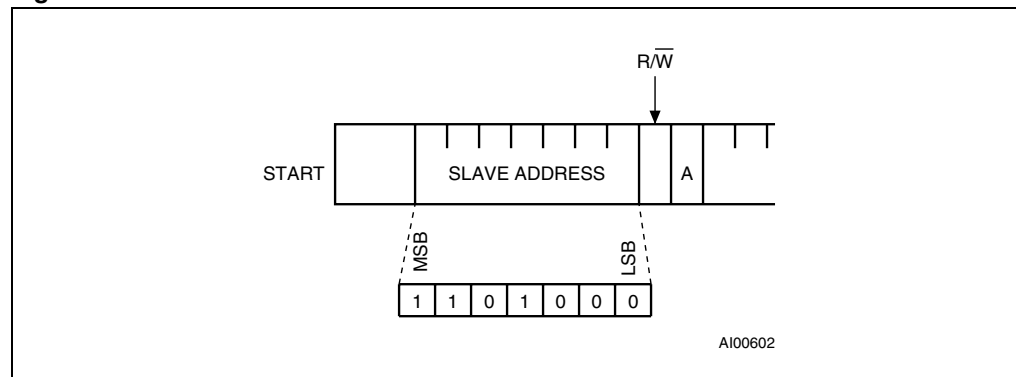


Figure 10. Read mode sequence

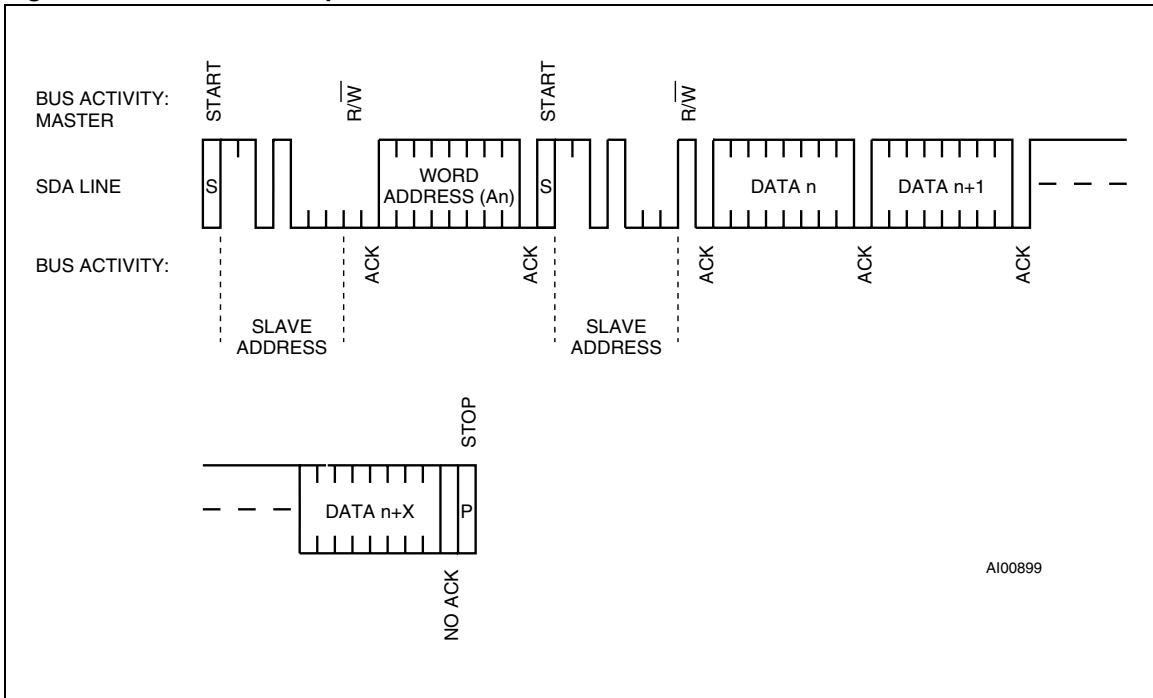
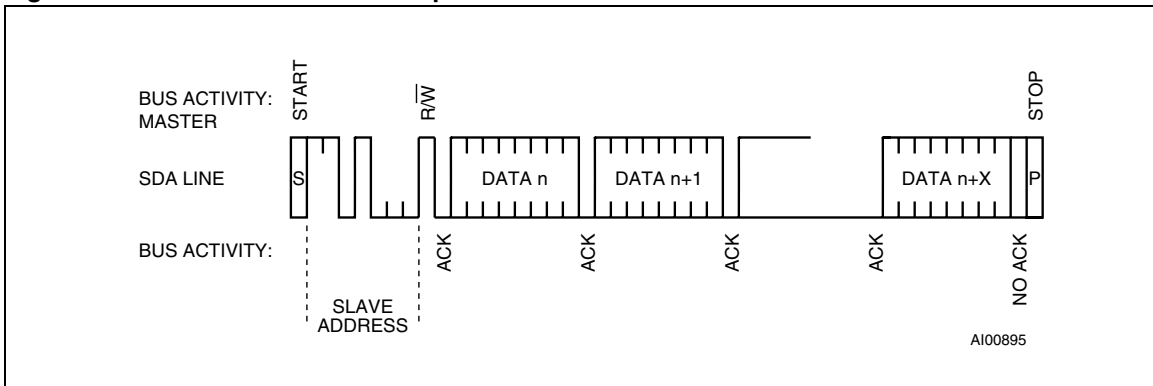


Figure 11. Alternate read mode sequence

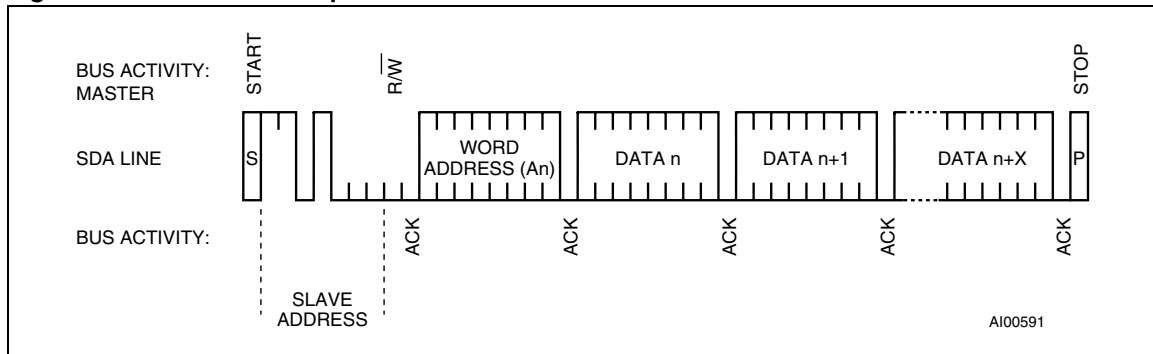




## 2.3 Write mode

In this mode the master transmitter transmits to the M41ST85W slave receiver. Bus protocol is shown in [Figure 12](#). Following the START condition and slave address, a logic '0' ( $\overline{R/\overline{W}}=0$ ) is placed on the bus and indicates to the addressed device that word address  $A_n$  will follow and is to be written to the on-chip address pointer. The data word to be written to the memory is strobed in next and the internal address pointer is incremented to the next memory location within the RAM on the reception of an acknowledge clock. The M41ST85W slave receiver will send an acknowledge clock to the master transmitter after it has received the slave address and again after it has received the word address and each data byte.

Figure 12. Write mode sequence



## 2.4 Data retention mode

With valid  $V_{CC}$  applied, the M41ST85W can be accessed as described above with READ or WRITE cycles. Should the supply voltage decay, the M41ST85W will automatically deselect, write protecting itself (and any external SRAM) when  $V_{CC}$  falls between  $V_{PFD(max)}$  and  $V_{PFD(min)}$ . This is accomplished by internally inhibiting access to the clock registers. At this time, the reset pin ( $\overline{RST}$ ) is driven active and will remain active until  $V_{CC}$  returns to nominal levels. External RAM access is inhibited in a similar manner by forcing  $\overline{ECON}$  to a high level. This level is within 0.2 volts of the  $V_{BAT}$ .  $\overline{ECON}$  will remain at this level as long as  $V_{CC}$  remains at an out-of-tolerance condition. When  $V_{CC}$  falls below the battery backup switchover voltage ( $V_{SO}$ ), power input is switched from the  $V_{CC}$  pin to the SNAPHAT<sup>®</sup> battery, and the clock registers and external SRAM are maintained from the attached battery supply.

All outputs become high impedance. The  $V_{OUT}$  pin is capable of supplying 100  $\mu A$  of current to the attached memory with less than 0.3 volts drop under this condition. On power-up, when  $V_{CC}$  returns to a nominal value, write protection continues for  $t_{rec}$  by inhibiting  $\overline{ECON}$ . The  $\overline{RST}$  signal also remains active during this time (see [Figure 20 on page 33](#)).

**Note:** *Most low power SRAMs on the market today can be used with the M41ST85W RTC SUPERVISOR. There are, however some criteria which should be used in making the final choice of an SRAM to use. The SRAM must be designed in a way where the chip enable input disables all other inputs to the SRAM. This allows inputs to the M41ST85W and SRAMs to be "Don't Care" once  $V_{CC}$  falls below  $V_{PFD(min)}$ . The SRAM should also guarantee data retention down to  $V_{CC} = 2.0$  volts. The chip enable access time must be sufficient to meet the system needs with the chip enable output propagation delays included. If the SRAM includes a second chip enable pin (E2), this pin should be tied to  $V_{OUT}$ .*

If data retention lifetime is a critical parameter for the system, it is important to review the data retention current specifications for the particular SRAMs being evaluated. Most SRAMs specify a data retention current at 3.0 volts. Manufacturers generally specify a typical condition for room temperature along with a worst case condition (generally at elevated temperatures). The system level requirements will determine the choice of which value to use. The data retention current value of the SRAMs can then be added to the  $I_{BAT}$  value of the M41ST85W to determine the total current requirements for data retention. The available battery capacity for the SNAPHAT<sup>®</sup> top of your choice can then be divided by this current to determine the amount of data retention available (see [Table 19 on page 38](#)).

For a further more detailed review of lifetime calculations, please see application note AN1012.

## 3 Clock operation

The eight byte clock register (see [Table 2 on page 20](#)) is used to both set the clock and to read the date and time from the clock, in a binary coded decimal format. Tenths/hundredths of seconds, seconds, minutes, and hours are contained within the first four registers.

*Note:* A WRITE to any clock register will result in the tenths/hundredths of seconds being reset to "00," and tenths/hundredths of seconds cannot be written to any value other than "00."

Bits D6 and D7 of clock register 03h (century/hours register) contain the CENTURY ENABLE bit (CEB) and the CENTURY bit (CB). Setting CEB to a '1' will cause CB to toggle, either from '0' to '1' or from '1' to '0' at the turn of the century (depending upon its initial state). If CEB is set to a '0,' CB will not toggle. Bits D0 through D2 of register 04h contain the day (day of week). Registers 05h, 06h, and 07h contain the date (day of month), month and years. The ninth clock register is the control register (this is described in the clock calibration section). Bit D7 of register 01h contains the STOP bit (ST). Setting this bit to a '1' will cause the oscillator to stop. If the device is expected to spend a significant amount of time on the shelf, the oscillator may be stopped to reduce current drain. When reset to a '0' the oscillator restarts within one second.

The eight clock registers may be read one byte at a time, or in a sequential block. The control register (address location 08h) may be accessed independently. Provision has been made to assure that a clock update does not occur while any of the eight clock addresses are being read. If a clock address is being read, an update of the clock registers will be halted. This will prevent a transition of data during the READ.

### 3.1 Power-down time-stamp

When a power failure occurs, the halt update bit (HT) will automatically be set to a '1.' This will prevent the clock from updating the TIMEKEEPER® registers, and will allow the user to read the exact time of the power-down event. Resetting the HT bit to a '0' will allow the clock to update the TIMEKEEPER registers with the current time. For more information, see application note AN1572.

### 3.2 TIMEKEEPER® registers

The M41ST85W offers 20 internal registers which contain clock, alarm, watchdog, flag, square wave and control data. These registers are memory locations which contain external (user accessible) and internal copies of the data (usually referred to as BiPORT™ TIMEKEEPER cells). The external copies are independent of internal functions except that they are updated periodically by the simultaneous transfer of the incremented internal copy. The internal divider (or clock) chain will be reset upon the completion of a WRITE to any clock address.

The system-to-user transfer of clock data will be halted whenever the address being read is a clock address (00h to 07h). The update will resume either due to a stop condition or when the pointer increments to a non-clock or RAM address.

TIMEKEEPER and alarm registers store data in BCD. control, watchdog and square wave registers store data in binary format.

Table 2. TIMEKEEPER® register map

Address	Data								Function/range BCD format	
	D7	D6	D5	D4	D3	D2	D1	D0		
00h	0.1 seconds				0.01 seconds				Seconds	00-99
01h	ST	10 seconds			Seconds				Seconds	00-59
02h	0	10 minutes			Minutes				Minutes	00-59
03h	CEB	CB	10 hours		Hours (24-hour format)				Century/hours	0-1/00-23
04h	TR	0	0	0	0	Day of week			Day	01-7
05h	0	0	10 date		Date: day of month				Date	01-31
06h	0	0	0	10M	Month				Month	01-12
07h	10 years				Year				Year	00-99
08h	OUT	FT	S	Calibration					Control	
09h	WDS	BMB4	BMB3	BMB2	BMB1	BMB0	RB1	RB0	Watchdog	
0Ah	AFE	SQWE	ABE	AI 10M	Alarm month				AI month	01-12
0Bh	RPT4	RPT5	AI 10 date		Alarm date				AI date	01-31
0Ch	RPT3	HT	AI 10 hour		Alarm hour				AI hour	00-23
0Dh	RPT2	Alarm 10 minutes			Alarm minutes				AI min	00-59
0Eh	RPT1	Alarm 10 seconds			Alarm seconds				AI sec	00-59
0Fh	WDF	AF	0	BL	0	0	0	0	Flags	
10h	0	0	0	0	0	0	0	0	Reserved	
11h	0	0	0	0	0	0	0	0	Reserved	
12h	0	0	0	0	0	0	0	0	Reserved	
13h	RS3	RS2	RS1	RS0	0	0	0	0	SQW	

Keys: S = Sign bit

FT = Frequency test bit

ST = Stop bit

0 = Must be set to zero

BL = Battery low flag (read only)

BMB0-BMB4 = Watchdog multiplier bits

CEB = Century enable bit

CB = Century bit

OUT = Output level

AFE = Alarm flag enable flag

RB0-RB1 = Watchdog resolution bits

WDS = Watchdog steering bit

ABE = Alarm in battery backup mode enable bit

RPT1-RPT5 = Alarm repeat mode bits

WDF = Watchdog flag (read only)

AF = Alarm flag (read only)

SQWE = Square wave enable

RS0-RS3 = SQW frequency

HT = Halt update bit

TR =  $t_{rec}$  bit

### 3.3 Calibrating the clock

The M41ST85W is driven by a quartz controlled oscillator with a nominal frequency of 32,768 Hz. The devices are tested not exceed  $\pm 35$  ppm (parts per million) oscillator frequency error at 25°C, which equates to about  $\pm 1.53$  minutes per month. When the Calibration circuit is properly employed, accuracy improves to better than  $\pm 2$  ppm at 25°C.

The oscillation rate of crystals changes with temperature (see [Figure 13 on page 22](#)). Therefore, the M41ST85W design employs periodic counter correction. The calibration circuit adds or subtracts counts from the oscillator divider circuit at the divide by 256 stage, as shown in [Figure 14 on page 22](#). The number of times pulses which are blanked (subtracted, negative calibration) or split (added, positive calibration) depends upon the value loaded into the five calibration bits found in the control register. Adding counts speeds the clock up, subtracting counts slows the clock down.

The calibration bits occupy the five lower order bits (D4-D0) in the control register (08h). These bits can be set to represent any value between 0 and 31 in binary form. Bit D5 is a sign bit; '1' indicates positive calibration, '0' indicates negative calibration. Calibration occurs within a 64 minute cycle. The first 62 minutes in the cycle may, once per minute, have one second either shortened by 128 or lengthened by 256 oscillator cycles. If a binary '1' is loaded into the register, only the first 2 minutes in the 64 minute cycle will be modified; if a binary 6 is loaded, the first 12 will be affected, and so on.

Therefore, each calibration step has the effect of adding 512 or subtracting 256 oscillator cycles for every 125,829,120 actual oscillator cycles, that is  $+4.068$  or  $-2.034$  ppm of adjustment per calibration step in the calibration register. Assuming that the oscillator is running at exactly 32,768 Hz, each of the 31 increments in the calibration byte would represent  $+10.7$  or  $-5.35$  seconds per month which corresponds to a total range of  $+5.5$  or  $-2.75$  minutes per month.

Two methods are available for ascertaining how much calibration a given M41ST85W may require.

The first involves setting the clock, letting it run for a month and comparing it to a known accurate reference and recording deviation over a fixed period of time. Calibration values, including the number of seconds lost or gained in a given period, can be found in application note AN934, "TIMEKEEPER<sup>®</sup> calibration." This allows the designer to give the end user the ability to calibrate the clock as the environment requires, even if the final product is packaged in a non-user serviceable enclosure. The designer could provide a simple utility that accesses the calibration byte.

The second approach is better suited to a manufacturing environment, and involves the use of the  $\overline{\text{IRQ}}/\text{FT}/\text{OUT}$  pin. The pin will toggle at 512 Hz, when the stop bit (ST, D7 of 01h) is '0,' the frequency test bit (FT, D6 of 08h) is '1,' the alarm flag enable bit (AFE, D7 of 0Ah) is '0,' and the watchdog steering bit (WDS, D7 of 09h) is '1' or the watchdog register (09h = 0) is reset.

Any deviation from 512 Hz indicates the degree and direction of oscillator frequency shift at the test temperature. For example, a reading of 512.010124 Hz would indicate a  $+20$  ppm oscillator frequency error, requiring a  $-10$  (XX001010) to be loaded into the calibration byte for correction. Note that setting or changing the calibration byte does not affect the frequency test output frequency.

The  $\overline{\text{IRQ}}/\text{FT}/\text{OUT}$  pin is an open drain output which requires a pull-up resistor to  $V_{\text{CC}}$  for proper operation. A 500 to 10 k resistor is recommended in order to control the rise time. The FT bit is cleared on power-down.

Figure 13. Crystal accuracy across temperature

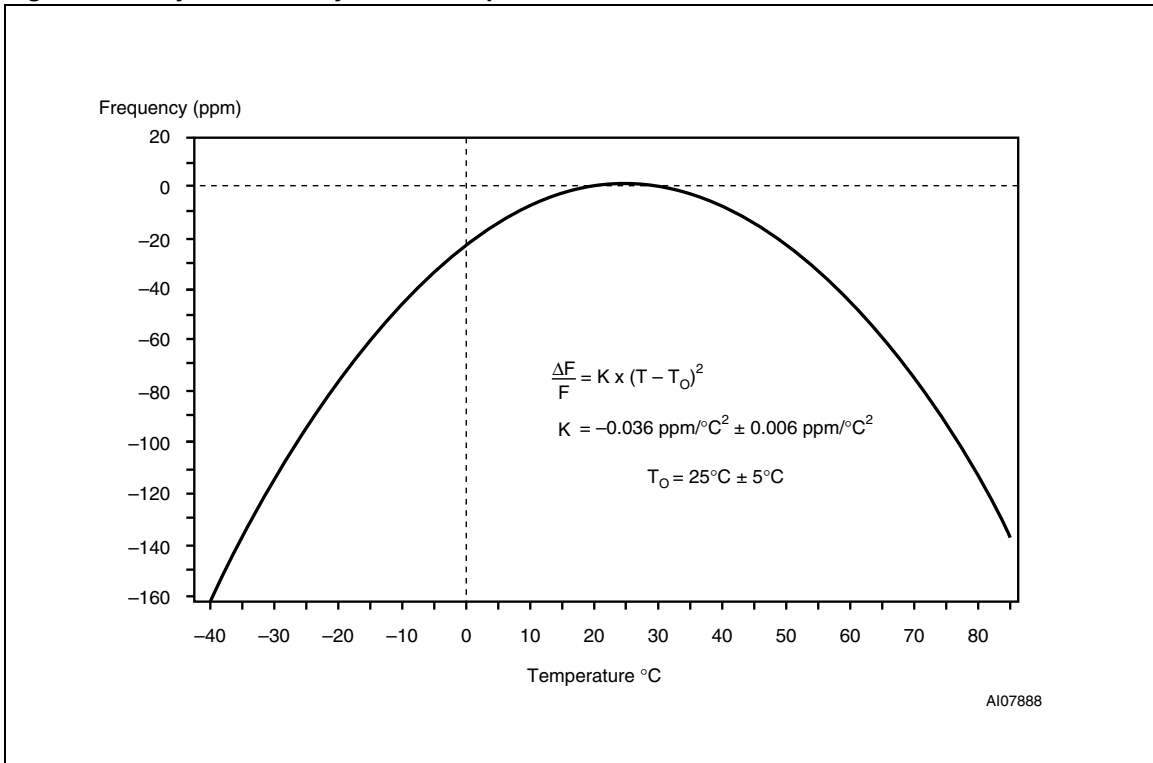
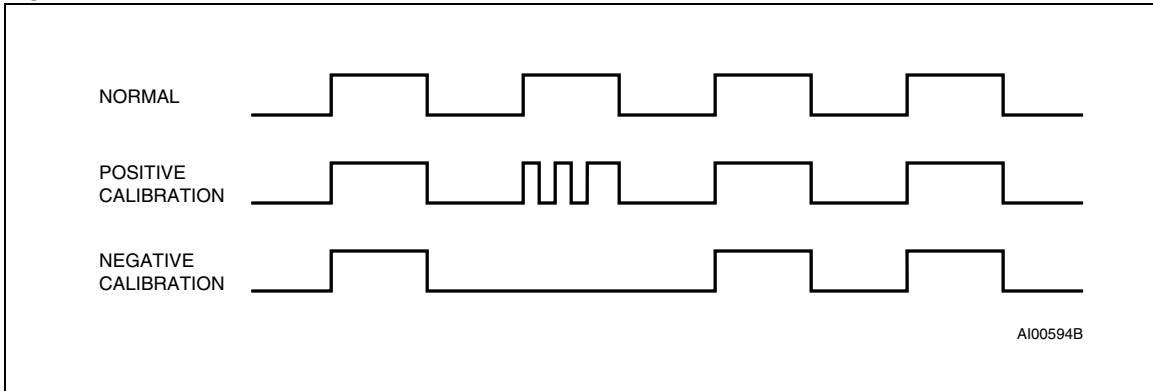


Figure 14. Calibration waveform



### 3.4 Setting alarm clock registers

Address locations 0Ah-0Eh contain the alarm settings. The alarm can be configured to go off at a prescribed time on a specific month, date, hour, minute, or second, or repeat every year, month, day, hour, minute, or second. It can also be programmed to go off while the M41ST85W is in the battery backup to serve as a system wake-up call.

Bits RPT5–RPT1 put the alarm in the repeat mode of operation. [Table 3](#) shows the possible configurations. Codes not listed in the table default to the once per second mode to quickly alert the user of an incorrect alarm setting.

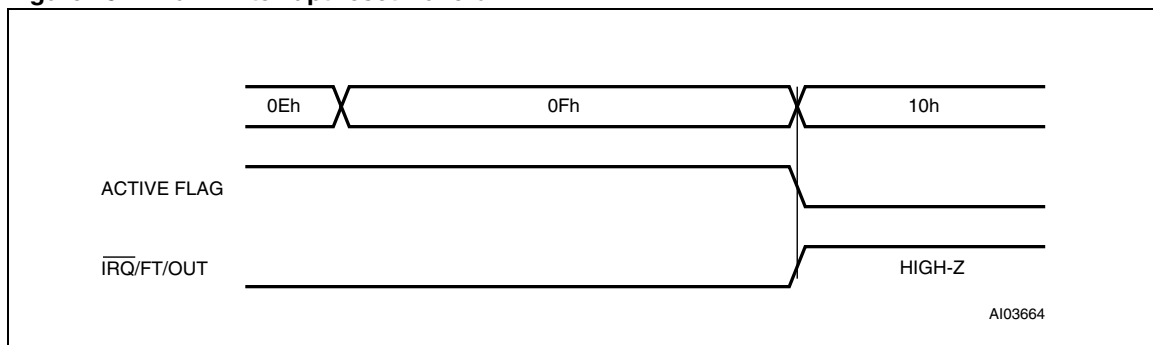
When the clock information matches the alarm clock settings based on the match criteria defined by RPT5–RPT1, the AF (alarm flag) is set. If AFE (alarm flag enable) is also set, the alarm condition activates the  $\overline{\text{IRQ}}/\text{FT}/\text{OUT}$  pin as shown in [Figure 15](#). To disable alarm, write '0' to the alarm date register and to RPT5–RPT1.

*Note:* If the address pointer is allowed to increment to the flag register address, an alarm condition will not cause the interrupt/flag to occur until the address pointer is moved to a different address. It should also be noted that if the last address written is the “Alarm Seconds,” the address pointer will increment to the flag address, causing this situation to occur.

The  $\overline{\text{IRQ}}/\text{FT}/\text{OUT}$  output is cleared by a READ to the flags register. A subsequent READ of the flags register is necessary to see that the value of the alarm flag has been reset to '0.'

The  $\overline{\text{IRQ}}/\text{FT}/\text{OUT}$  pin can also be activated in the battery backup mode. The  $\overline{\text{IRQ}}/\text{FT}/\text{OUT}$  will go low if an alarm occurs and both ABE (alarm in battery backup mode enable) and AFE are set. The ABE and AFE bits are reset during power-up, therefore an alarm generated during power-up will only set AF. The user can read the flag register at system boot-up to determine if an alarm was generated while the M41ST85W was in the deselect mode during power-up. [Figure 16 on page 24](#) illustrates the backup mode alarm timing.

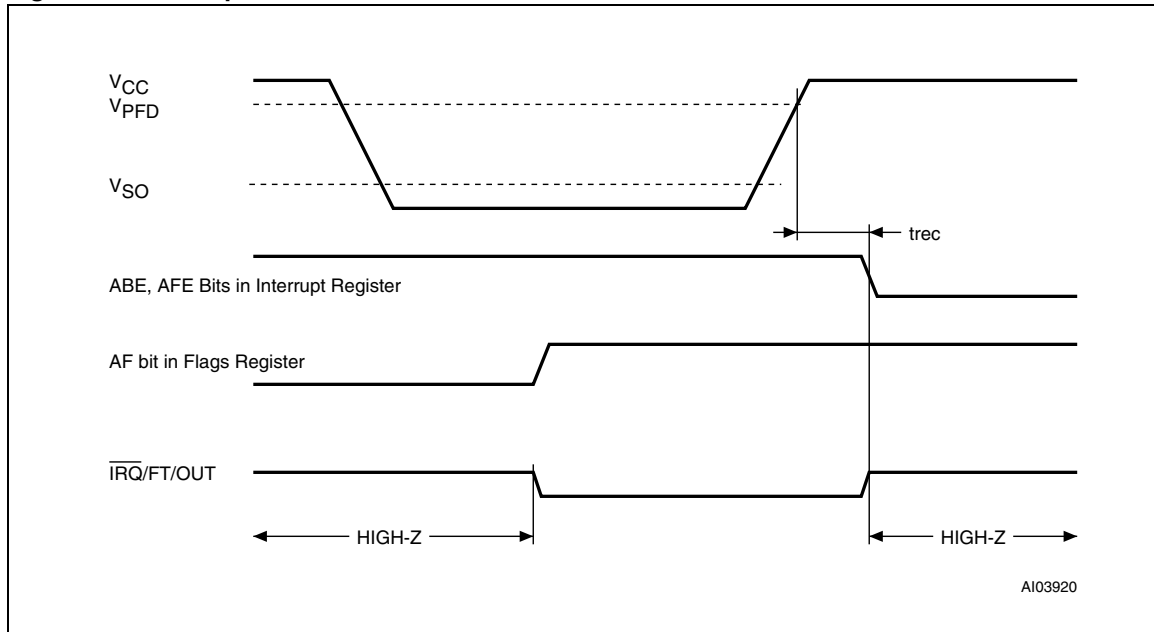
**Figure 15. Alarm interrupt reset waveform**



**Table 3. Alarm repeat modes**

RPT5	RPT4	RPT3	RPT2	RPT1	Alarm setting
1	1	1	1	1	Once per second
1	1	1	1	0	Once per minute
1	1	1	0	0	Once per hour
1	1	0	0	0	Once per day
1	0	0	0	0	Once per month
0	0	0	0	0	Once per year

Figure 16. Backup mode alarm waveform



### 3.5 Watchdog timer

The watchdog timer can be used to detect an out-of-control microprocessor. The user programs the watchdog timer by setting the desired amount of time-out into the watchdog register, address 09h. Bits BMB4-BMB0 store a binary multiplier and the two lower order bits RB1-RB0 select the resolution, where 00 = 1/16 second, 01 = 1/4 second, 10 = 1 second, and 11 = 4 seconds. The amount of time-out is then determined to be the multiplication of the five-bit multiplier value with the resolution. (For example: writing 00001110 in the watchdog register = 3\*1 or 3 seconds).

*Note:* The accuracy of the timer is within  $\pm$  the selected resolution.

If the processor does not reset the timer within the specified period, the M41ST85W sets the WDF (watchdog flag) and generates a watchdog interrupt or a microprocessor reset.

The most significant bit of the watchdog register is the watchdog steering bit (WDS). When set to a '0,' the watchdog will activate the  $\overline{\text{IRQ/FT/OUT}}$  pin when timed-out. When WDS is set to a '1,' the watchdog will output a negative pulse on the  $\overline{\text{RST}}$  pin for  $t_{\text{rec}}$ . The watchdog register, FT, AFE, ABE and SQWE bits will reset to a '0' at the end of a watchdog time-out when the WDS bit is set to a '1.'

The watchdog timer can be reset by two methods: 1) a transition (high-to-low or low-to-high) can be applied to the watchdog input pin (WDI) or 2) the microprocessor can perform a WRITE of the watchdog register. The time-out period then starts over.

*Note:* The WDI pin should be tied to  $V_{SS}$  if not used.

In order to perform a software reset of the watchdog timer, the original time-out period can be written into the watchdog register, effectively restarting the count-down cycle.

Should the watchdog timer time-out, and the WDS bit is programmed to output an interrupt, a value of 00h needs to be written to the watchdog register in order to clear the  $\overline{\text{IRQ/FT/OUT}}$



pin. This will also disable the watchdog function until it is again programmed correctly. A READ of the flags register will reset the watchdog flag (bit D7; register 0Fh).

The watchdog function is automatically disabled upon power-up and the watchdog register is cleared. If the watchdog function is set to output to the  $\overline{\text{IRQ/FT/OUT}}$  pin and the frequency test function is activated, the watchdog function prevails and the frequency test function is denied.

### 3.6 Square wave output

The M41ST85W offers the user a programmable square wave function which is output on the SQW pin. RS3-RS0 bits located in 13h establish the square wave output frequency. These frequencies are listed in [Table 4](#). Once the selection of the SQW frequency has been completed, the SQW pin can be turned on and off under software control with the square wave enable bit (SQWE) located in register 0Ah.

**Table 4. Square wave output frequency**

Square wave bits				Square wave	
RS3	RS2	RS1	RS0	Frequency	Units
0	0	0	0	None	–
0	0	0	1	32.768	kHz
0	0	1	0	8.192	kHz
0	0	1	1	4.096	kHz
0	1	0	0	2.048	kHz
0	1	0	1	1.024	kHz
0	1	1	0	512	Hz
0	1	1	1	256	Hz
1	0	0	0	128	Hz
1	0	0	1	64	Hz
1	0	1	0	32	Hz
1	0	1	1	16	Hz
1	1	0	0	8	Hz
1	1	0	1	4	Hz
1	1	1	0	2	Hz
1	1	1	1	1	Hz

### 3.7 Power-on reset

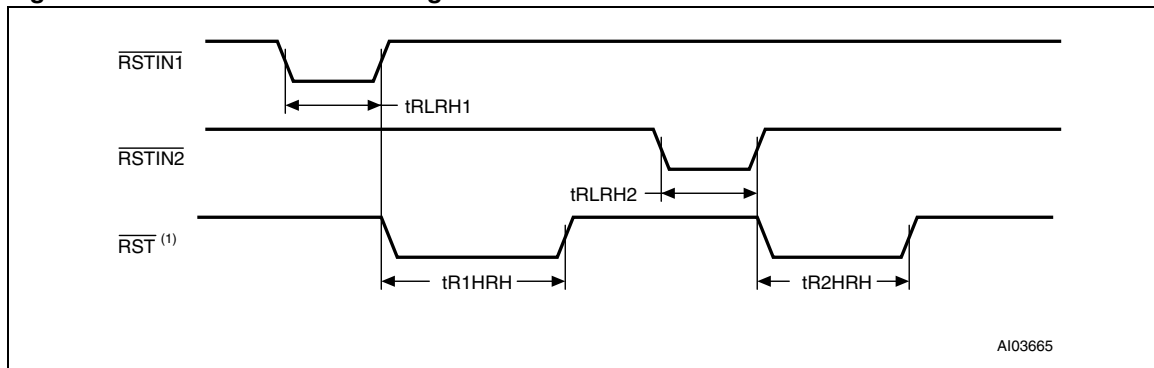
The M41ST85W continuously monitors  $V_{CC}$ . When  $V_{CC}$  falls to the power fail detect trip point, the  $\overline{\text{RST}}$  pulls low (open drain) and remains low on power-up for  $t_{rec}$  after  $V_{CC}$  passes  $V_{PFD(max)}$ . The  $\overline{\text{RST}}$  pin is an open drain output and an appropriate pull-up resistor should be chosen to control rise time.

### 3.8 Reset inputs ( $\overline{\text{RSTIN1}}$ & $\overline{\text{RSTIN2}}$ )

The M41ST85W provides two independent inputs which can generate an output reset. The duration and function of these resets is identical to a reset generated by a power cycle.

[Table 5](#) and [Figure 17](#) illustrate the AC reset characteristics of this function. Pulses shorter than  $t_{\text{RLRH1}}$  and  $t_{\text{RLRH2}}$  will not generate a reset condition.  $\overline{\text{RSTIN1}}$  and  $\overline{\text{RSTIN2}}$  are each internally pulled up to  $V_{\text{CC}}$  through a 100 k $\Omega$  resistor.

Figure 17.  $\overline{\text{RSTIN1}}$  &  $\overline{\text{RSTIN2}}$  timing waveforms



Note: With pull-up resistor

Table 5. Reset AC characteristics

Symbol	Parameter <sup>(1)</sup>	Min	Max	Unit
$t_{\text{RLRH1}}$ <sup>(2)</sup>	$\overline{\text{RSTIN1}}$ low to $\overline{\text{RSTIN1}}$ high	200		ns
$t_{\text{RLRH2}}$ <sup>(3)</sup>	$\overline{\text{RSTIN2}}$ low to $\overline{\text{RSTIN2}}$ high	100		ms
$t_{\text{R1HRH}}$ <sup>(4)</sup>	$\overline{\text{RSTIN1}}$ high to $\overline{\text{RST}}$ high	40	200	ms
$t_{\text{R2HRH}}$ <sup>(4)</sup>	$\overline{\text{RSTIN2}}$ high to $\overline{\text{RST}}$ high	40	200	ms

- Valid for ambient operating temperature:  $T_A = -40$  to  $85^\circ\text{C}$ ;  $V_{\text{CC}} = 2.7$  to  $3.6$  V (except where noted).
- Pulse width less than 50 ns will result in no RESET (for noise immunity).
- Pulse width less than 20 ms will result in no RESET (for noise immunity).
- Programmable (see [Table 6 on page 28](#)).

### 3.9 Power-fail input/output

The power-fail input (PFI) is compared to an internal reference voltage (1.25 V). If PFI is less than the power-fail threshold ( $V_{\text{PFI}}$ ), the power-fail output ( $\overline{\text{PFO}}$ ) will go low. This function is intended for use as an undervoltage detector to signal a failing power supply. Typically PFI is connected through an external voltage divider (see [Figure 5 on page 11](#)) to either the unregulated DC input (if it is available) or the regulated output of the  $V_{\text{CC}}$  regulator. The voltage divider can be set up such that the voltage at PFI falls below  $V_{\text{PFI}}$  several milliseconds before the regulated  $V_{\text{CC}}$  input to the M41ST85W or the microprocessor drops below the minimum operating voltage.

During battery backup, the power-fail comparator turns off and  $\overline{\text{PFO}}$  goes (or remains) low. This occurs after  $V_{\text{CC}}$  drops below  $V_{\text{PFD(min)}}$ . When power returns,  $\overline{\text{PFO}}$  is forced high, irrespective of  $V_{\text{PFI}}$  for the write protect time ( $t_{\text{rec}}$ ), which is the time from  $V_{\text{PFD(max)}}$  until the inputs are recognized. At the end of this time, the power-fail comparator is enabled and  $\overline{\text{PFO}}$

follows PFI. If the comparator is unused, PFI should be connected to  $V_{SS}$  and  $\overline{PFO}$  left unconnected.

### 3.10 Century bit

Bits D7 and D6 of clock register 03h contain the CENTURY ENABLE bit (CEB) and the CENTURY bit (CB). Setting CEB to a '1' will cause CB to toggle, either from a '0' to '1' or from '1' to '0' at the turn of the century (depending upon its initial state). If CEB is set to a '0', CB will not toggle.

### 3.11 Output driver pin

When the FT bit, AFE bit and watchdog register are not set, the  $\overline{IRQ}/FT/OUT$  pin becomes an output driver that reflects the contents of D7 of the control register. In other words, when D7 (OUT bit) and D6 (FT bit) of address location 08h are a '0,' then the  $\overline{IRQ}/FT/OUT$  pin will be driven low.

*Note:* The  $\overline{IRQ}/FT/OUT$  pin is an open drain which requires an external pull-up resistor.

### 3.12 Battery low warning

The M41ST85W automatically performs battery voltage monitoring upon power-up and at factory-programmed time intervals of approximately 24 hours. The battery low (BL) bit, bit D4 of flags register 0Fh, will be asserted if the battery voltage is found to be less than approximately 2.5 V. The BL bit will remain asserted until completion of battery replacement and subsequent battery low monitoring tests, either during the next power-up sequence or the next scheduled 24-hour interval.

If a battery low is generated during a power-up sequence, this indicates that the battery is below approximately 2.5 volts and may not be able to maintain data integrity in the SRAM. Data should be considered suspect and verified as correct. A fresh battery should be installed.

If a battery low indication is generated during the 24-hour interval check, this indicates that the battery is near end of life. However, data is not compromised due to the fact that a nominal  $V_{CC}$  is supplied. In order to insure data integrity during subsequent periods of battery backup mode, the battery should be replaced. The SNAPHAT<sup>®</sup> top may be replaced while  $V_{CC}$  is applied to the device.

*Note:* This will cause the clock to lose time during the interval the SNAPHAT battery/crystal top is disconnected.

The M41ST85W only monitors the battery when a nominal  $V_{CC}$  is applied to the device. Thus applications which require extensive durations in the battery backup mode should be powered-up periodically (at least once every few months) in order for this technique to be beneficial. Additionally, if a battery low is indicated, data integrity should be verified upon power-up via a checksum or other technique.

### 3.13 $t_{rec}$ bit

Bit D7 of clock register 04h contains the  $t_{rec}$  bit (TR).  $t_{rec}$  refers to the automatic continuation of the deselect time after  $V_{CC}$  reaches  $V_{PFD}$ . This allows for a voltage settling time before WRITES may again be performed to the device after a power-down condition. The  $t_{rec}$  bit will allow the user to set the length of this deselect time as defined by [Table 6](#).

### 3.14 Initial power-on defaults

Upon initial application of power to the device, the following register bits are set to a '0' state: watchdog register, FT, AFE, ABE, SQWE, and TR. The following bits are set to a '1' state: ST, OUT, and HT (see [Table 7](#)).

**Table 6.**  $t_{rec}$  definitions

$t_{rec}$ bit (TR)	STOP bit (ST)	$t_{rec}$ time		Units
		Min	Max	
0	0	96	98	ms
0	1	40	200 <sup>(1)</sup>	ms
1	X	50	2000	$\mu$ s

1. Default setting

**Table 7.** Default values

Condition	TR	ST	HT	Out	FT	AFE	ABE	SQWE	Watchdog register <sup>(1)</sup>
Initial power-up <sup>(2)</sup>	0	1	1	1	0	0	0	0	0
Subsequent power-up (with battery backup) <sup>(3)</sup>	UC	UC	1	UC	0	0	0	0	0

1. WDS, BMB0-BMB4, RB0, RB1.

2. State of other control bits undefined.

3. UC = Unchanged

## 4 Maximum ratings

Stressing the device above the rating listed in the absolute maximum ratings table may cause permanent damage to the device. These are stress ratings only and operation of the device at these or any other conditions above those indicated in the operating sections of this specification is not implied. Exposure to absolute maximum rating conditions for extended periods may affect device reliability. Refer also to the STMicroelectronics SURE Program and other relevant quality documents.

**Table 8. Absolute maximum ratings**

Symbol	Parameter	Value	Unit	
T <sub>STG</sub>	Storage temperature (V <sub>CC</sub> off, oscillator off)	SNAPHAT <sup>®</sup>	-40 to 85	°C
		SOIC	-55 to 150	°C
T <sub>SLD</sub>	Lead solder temperature for 10 seconds	SOH28 <sup>(1)</sup>	260	°C
		SOX28 <sup>(2)</sup>	240	°C
V <sub>IO</sub>	Input or output voltage	-0.3 to V <sub>CC</sub> +0.3	V	
V <sub>CC</sub>	Supply voltage	-0.3 to 4.6	V	
I <sub>O</sub>	Output current	20	mA	
P <sub>D</sub>	Power dissipation	1	W	

1. For SOH28 package, lead-free (pb-free) lead finish: reflow at peak temperature of 260°C (the time above 255°C must not exceed 30 seconds).

2. The SOX28 package has lead-free (pb-free) lead finish, but cannot be exposed to peak reflow temperature in excess of 240°C. Reflow at peak temperature of 240°C (the time above 235°C must not exceed 20 seconds).

**Caution:** *Negative undershoots below -0.3 V are not allowed on any pin while in the battery backup mode.*

**Caution:** *Do NOT wave solder SOIC to avoid damaging SNAPHAT sockets.*

## 5 DC and AC parameters

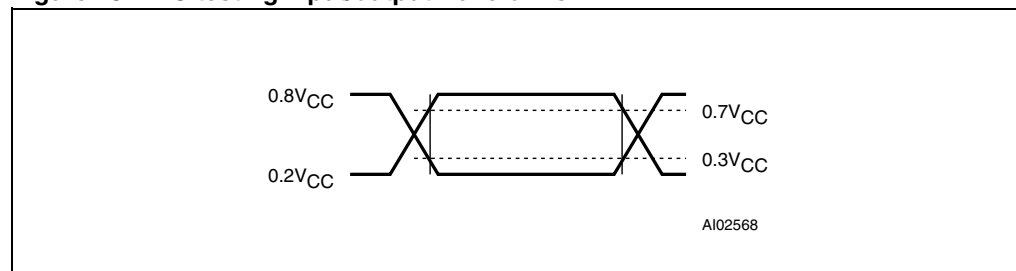
This section summarizes the operating and measurement conditions, as well as the DC and AC characteristics of the device. The parameters in the following DC and AC characteristic tables are derived from tests performed under the measurement conditions listed in the relevant tables. Designers should check that the operating conditions in their projects match the measurement conditions when using the quoted parameters.

**Table 9. DC and AC measurement conditions**

Parameter	M41ST85W
$V_{CC}$ supply voltage	2.7 to 3.6 V
Ambient operating temperature	-40 to 85°C
Load capacitance ( $C_L$ )	50 pF
Input rise and fall times	$\leq 50$ ns
Input pulse voltages	0.2 to $0.8V_{CC}$
Input and output timing ref. voltages	0.3 to $0.7V_{CC}$

*Note:* Output High Z is defined as the point where data is no longer driven.

**Figure 18. AC testing input/output waveforms**



**Table 10. Capacitance**

Symbol	Parameter <sup>(1)(2)</sup>	Min	Max	Unit
$C_{IN}$	Input capacitance		7	pF
$C_{OUT}^{(3)}$	Output capacitance		10	pF
$t_{LP}$	Low-pass filter input time constant (SDA and SCL)		50	ns

1. Effective capacitance measured with power supply at 5 V. Sampled only, not 100% tested.
2. At 25°C,  $f = 1$  MHz.
3. Outputs are deselected.

Table 11. DC characteristics

Sym	Parameter	Test condition <sup>(1)</sup>	M41ST85W			Unit
			Min	Typ	Max	
I <sub>BAT</sub> <sup>(2)</sup>	Battery current OSC ON	T <sub>A</sub> = 25°C, V <sub>CC</sub> = 0 V, V <sub>BAT</sub> = 3 V		400	500	nA
	Battery current OSC OFF			50		nA
I <sub>CC1</sub>	Supply current	f = 400 kHz			0.75	mA
I <sub>CC2</sub>	Supply current (standby)	SCL, SDA = V <sub>CC</sub> - 0.3 V or V <sub>SS</sub> + 0.3 V			0.50	mA
I <sub>LI</sub> <sup>(3)</sup>	Input leakage current	0V ≤ V <sub>IN</sub> ≤ V <sub>CC</sub>			±1	μA
	Input leakage current (PFI)		-25	2	25	nA
I <sub>LO</sub> <sup>(4)</sup>	Output leakage current	0V ≤ V <sub>IN</sub> ≤ V <sub>CC</sub>			±1	μA
I <sub>OUT1</sub> <sup>(5)</sup>	V <sub>OUT</sub> current (active)	V <sub>OUT1</sub> > V <sub>CC</sub> - 0.3 V			100	mA
I <sub>OUT2</sub>	V <sub>OUT</sub> current (battery backup)	V <sub>OUT2</sub> > V <sub>BAT</sub> - 0.3 V			100	μA
V <sub>IH</sub>	Input high voltage		0.7V <sub>CC</sub>		V <sub>CC</sub> + 0.3	V
V <sub>IL</sub>	Input low voltage		-0.3		0.3V <sub>CC</sub>	V
V <sub>BAT</sub>	Battery voltage		2.5	3.0	3.5 <sup>(6)</sup>	V
V <sub>OH</sub>	Output high voltage <sup>(7)</sup>	I <sub>OH</sub> = -1.0 mA	2.4			V
	Pull-up supply voltage (open drain)	$\overline{\text{RST}}$ , $\overline{\text{IRQ/FT/OUT}}$			3.6	V
V <sub>OHB</sub> <sup>(8)</sup>	V <sub>OH</sub> (battery backup)	I <sub>OUT2</sub> = -1.0 μA	2.5	2.9	3.5	V
V <sub>OL</sub>	Output low voltage	I <sub>OL</sub> = 3.0 mA			0.4	V
	Output low voltage (open drain) <sup>(9)</sup>	I <sub>OL</sub> = 10 mA			0.4	V
V <sub>PFD</sub>	Power fail deselect		2.55	2.60	2.70	V
V <sub>PFI</sub>	PFI input threshold	V <sub>CC</sub> = 3 V(W)	1.225	1.250	1.275	V
	PFI hysteresis	PFI rising		20	70	mV
V <sub>SO</sub>	Battery backup switchover			2.5		V

- Valid for ambient operating temperature: T<sub>A</sub> = -40 to 85°C; V<sub>CC</sub> = 2.7 to 3.6 V (except where noted).
- Measured with V<sub>OUT</sub> and  $\overline{\text{E}}_{\text{CON}}$  open.
- $\overline{\text{RSTIN1}}$  and  $\overline{\text{RSTIN2}}$  internally pulled-up to V<sub>CC</sub> through 100 KΩ resistor. WDI internally pulled-down to V<sub>SS</sub> through 100 KΩ resistor.
- Outputs deselected.
- External SRAM must match RTC supervisor chip V<sub>CC</sub> specification.
- For rechargeable backup, V<sub>BAT</sub> (max) may be considered V<sub>CC</sub>.
- For  $\overline{\text{PFO}}$  and SQW pins (CMOS).
- Conditioned output ( $\overline{\text{E}}_{\text{CON}}$ ) can only sustain CMOS leakage current in the battery backup mode. Higher leakage currents will reduce battery life.
- For  $\overline{\text{IRQ/FT/OUT}}$ ,  $\overline{\text{RST}}$  pins (open drain): if pulled-up to supply other than V<sub>CC</sub>, this supply must be equal to, or less than 3.0 V when V<sub>CC</sub> = 0 V (during battery backup mode).

Figure 19. Bus timing requirements sequence

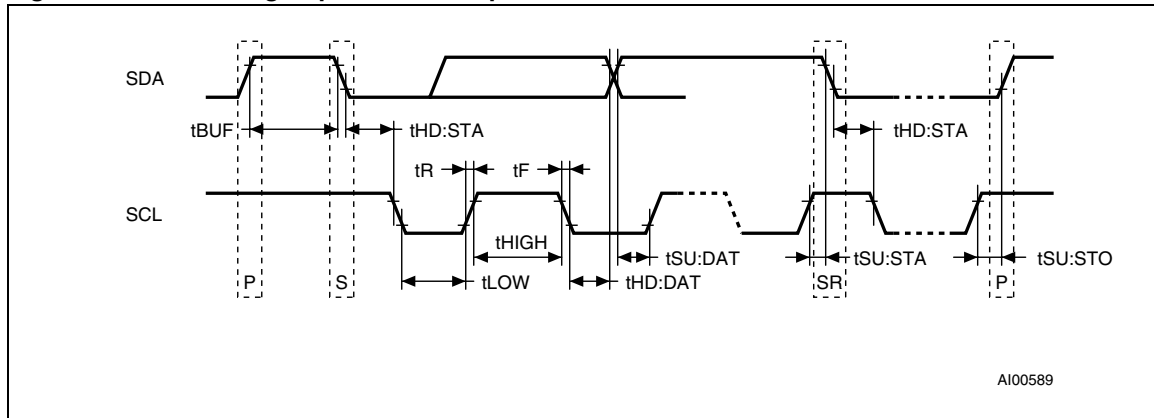


Table 12. AC characteristics

Symbol	Parameter <sup>(1)</sup>	Min	Max	Unit
$f_{SCL}$	SCL clock frequency	0	400	kHz
$t_{BUF}$	Time the bus must be free before a new transmission can start	1.3		$\mu s$
$t_{EXPD}$	$\overline{EX}$ to $\overline{E}_{CON}$ propagation delay		15	ns
$t_F$	SDA and SCL fall time		300	ns
$t_{HD:DAT}^{(2)}$	Data hold time	0		$\mu s$
$t_{HD:STA}$	START condition hold time (after this period the first clock pulse is generated)	600		ns
$t_{HIGH}$	Clock high period	600		ns
$t_{LOW}$	Clock low period	1.3		$\mu s$
$t_R$	SDA and SCL rise time		300	ns
$t_{SU:DAT}$	Data setup time	100		ns
$t_{SU:STA}$	START condition setup time (only relevant for a repeated start condition)	600		ns
$t_{SU:STO}$	STOP condition setup time	600		ns

- Valid for ambient operating temperature:  $T_A = -40$  to  $85^\circ C$ ;  $V_{CC} = 2.7$  to  $3.6$  V (except where otherwise noted).
- Transmitter must internally provide a hold time to bridge the undefined region (300 ns max) of the falling edge of SCL.



Figure 20. Power down/up mode AC waveforms

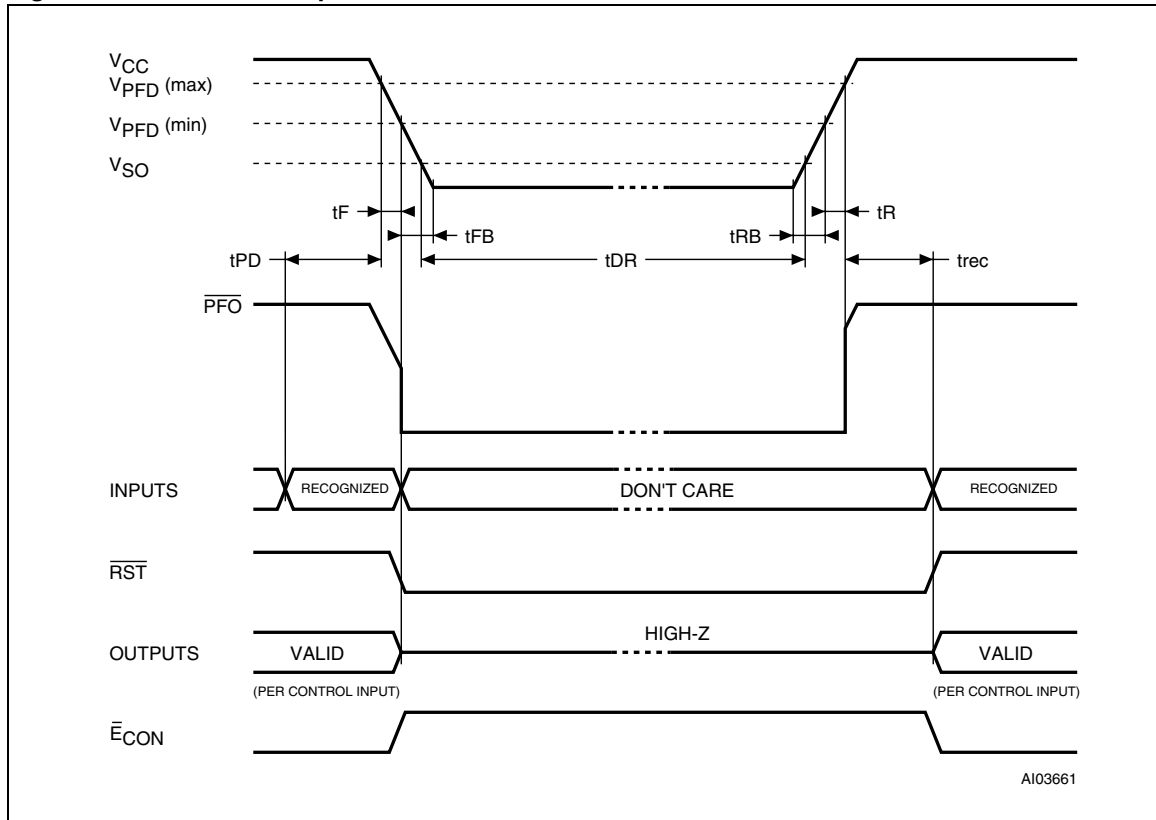


Table 13. Power down/up AC characteristics

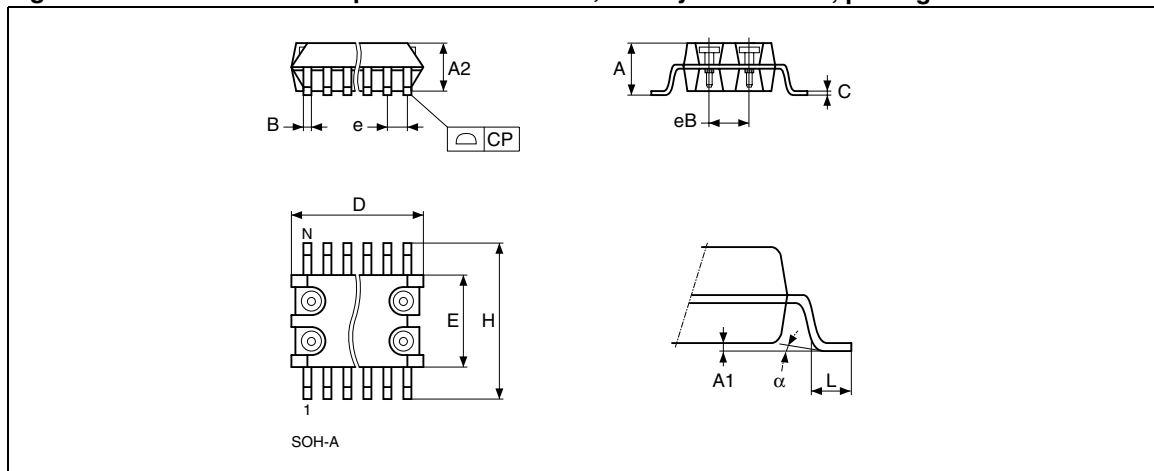
Symbol	Parameter <sup>(1)</sup>	Min	Typ	Max	Unit
$t_F^{(2)}$	$V_{PFD(max)}$ to $V_{PFD(min)}$ $V_{CC}$ fall time	300			$\mu s$
$t_{FB}^{(3)}$	$V_{PFD(min)}$ to $V_{SS}$ $V_{CC}$ fall time	10			$\mu s$
$t_{PD}$	$\overline{E\bar{X}}$ at $V_{IH}$ before power down	0			$\mu s$
$t_{PFD}$	PFI to $\overline{PFO}$ propagation delay		15	25	$\mu s$
$t_R$	$V_{PFD(min)}$ to $V_{PFD(max)}$ $V_{CC}$ rise time	10			$\mu s$
$t_{RB}$	$V_{SS}$ to $V_{PFD(min)}$ $V_{CC}$ rise time	1			$\mu s$
$t_{rec}^{(4)}$	Power-up deselect time	40		200	ms

- Valid for ambient operating temperature:  $T_A = -40$  to  $85^\circ C$ ;  $V_{CC} = 2.7$  to  $3.6$  V (except where otherwise noted).
- $V_{PFD(max)}$  to  $V_{PFD(min)}$  fall time of less than  $t_F$  may result in deselection/write protection not occurring until  $200 \mu s$  after  $V_{CC}$  passes  $V_{PFD(min)}$ .
- $V_{PFD(min)}$  to  $V_{SS}$  fall time of less than  $t_{FB}$  may cause corruption of RAM data.
- Programmable (see [Table 6 on page 28](#))

## 6 Package mechanical data

In order to meet environmental requirements, ST offers these devices in different grades of ECOPACK<sup>®</sup> packages, depending on their level of environmental compliance. ECOPACK<sup>®</sup> specifications, grade definitions and product status are available at: [www.st.com](http://www.st.com). ECOPACK<sup>®</sup> is an ST trademark.

Figure 21. SOH28 – 28-lead plastic small outline, battery SNAPHAT<sup>®</sup>, package outline

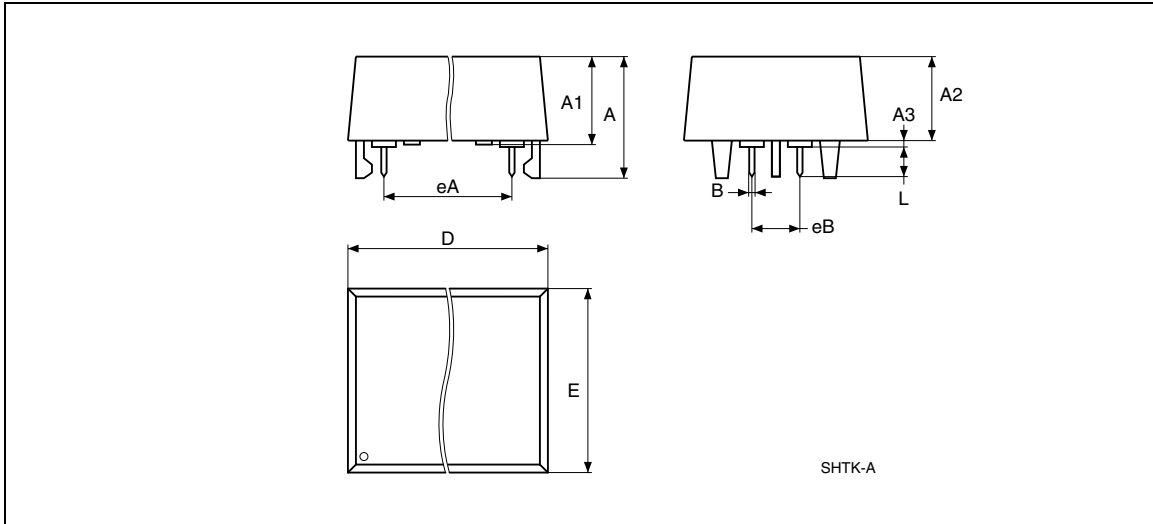


Note: Drawing is not to scale.

Table 14. SOH28 – 28-lead plastic small outline, battery SNAPHAT<sup>®</sup>, package mechanical data

Symbol	millimeters			inches		
	Typ	Min	Max	Typ	Min	Max
A			3.05			0.120
A1		0.05	0.36		0.002	0.014
A2		2.34	2.69		0.092	0.106
B		0.36	0.51		0.014	0.020
C		0.15	0.32		0.006	0.012
D		17.71	18.49		0.697	0.728
E		8.23	8.89		0.324	0.350
e	1.27	–	–	0.050	–	–
eB		3.20	3.61		0.126	0.142
H		11.51	12.70		0.453	0.500
L		0.41	1.27		0.016	0.050
a		0°	8°		0°	8°
N	28			28		
CP			0.10			0.004

Figure 22. SH – 4-pin SNAPHAT® housing for 48 mAh battery &amp; crystal, package outline

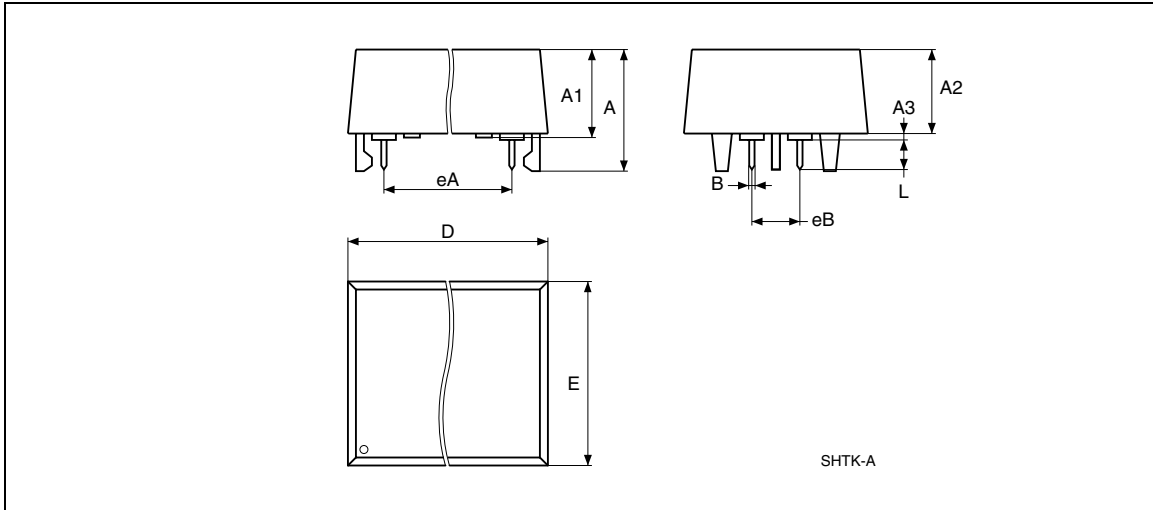


Note: Drawing is not to scale.

Table 15. SH – 4-pin SNAPHAT® housing for 48 mAh battery &amp; crystal, mechanical data

Symbol	millimeters			inches		
	Typ	Min	Max	Typ	Min	Max
A			9.78			0.3850
A1		6.73	7.24		0.2650	0.2850
A2		6.48	6.99		0.2551	0.2752
A3			0.38			0.0150
B		0.46	0.56		0.0181	0.0220
D		21.21	21.84		0.8350	0.8598
E		14.22	14.99		0.5598	0.5902
eA		15.55	15.95		0.6122	0.6280
eB		3.20	3.61		0.1260	0.1421
L		2.03	2.29		0.0799	0.0902

Figure 23. SH – 4-pin SNAPHAT® housing for 120 mAh battery & crystal, package outline

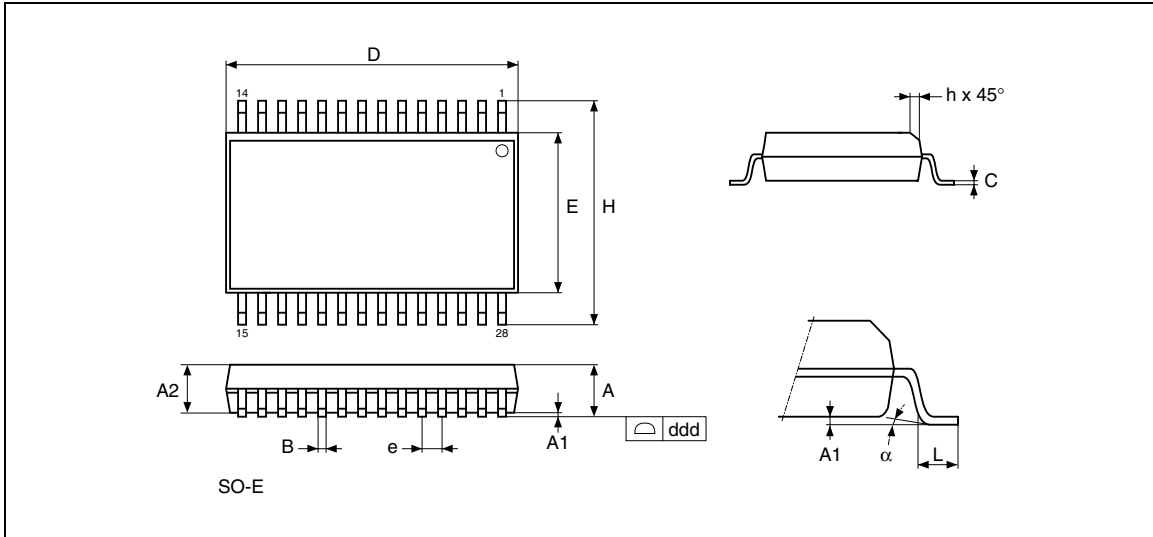


Note: Drawing is not to scale.

Table 16. SH – 4-pin SNAPHAT® housing for 120 mAh battery & crystal, mechanical data

Symbol	millimeters			inches		
	Typ	Min	Max	Typ	Min	Max
A			10.54			0.415
A1		8.00	8.51		0.315	0.335
A2		7.24	8.00		0.285	0.315
A3			0.38			0.015
B		0.46	0.56		0.018	0.022
D		21.21	21.84		0.835	0.860
E		17.27	18.03		0.680	0.710
eA		15.55	15.95		0.612	0.628
eB		3.20	3.61		0.126	0.142
L		2.03	2.29		0.080	0.090

Figure 24. SOX28 – 28-lead plastic small outline, 300 mils, embedded crystal, package outline



Note: Drawing is not to scale.

Table 17. SOX28 – 28-lead plastic small outline, 300 mils, embedded crystal, mechanical data

Symbol	millimeters			inches		
	Typ	Min	Max	Typ	Min	Max
A		2.44	2.69		0.096	0.106
A1		0.15	0.31		0.006	0.012
A2		2.29	2.39		0.090	0.094
B		0.41	0.51		0.016	0.020
C		0.20	0.31		0.008	0.012
D		17.91	18.01		0.705	0.709
ddd			0.10			0.004
E		7.57	7.67		0.298	0.302
e	1.27	–	–	0.050	–	–
H		10.16	10.52		0.400	0.414
L		0.51	0.81		0.020	0.032
a		0°	8°		0°	8°
N		28			28	

## 7 Part numbering

**Table 18. Ordering information scheme**

Example:	M41ST	85W	MH	6	E
<b>Device type</b>					
M41ST					
<b>Supply voltage and write protect voltage</b>					
85W = $V_{CC} = 2.7$ to $3.6$ V; $2.55V \leq V_{PFD} \leq 2.70$ V					
<b>Package</b>					
MH <sup>(1)</sup> = SOH28					
MX <sup>(2)</sup> = SOX28					
<b>Temperature range</b>					
6 = -40 to 85°C					
<b>Shipping method</b>					

**For SOH28:**

Blank = tubes (Not for New Design - use E)  
 E = ECOPACK<sup>®</sup> package, tubes  
 F = ECOPACK<sup>®</sup> package, tape & reel  
 TR = tape & reel (Not for New Design - use F)

**For SOX28:**

Blank = ECOPACK<sup>®</sup> package, tubes  
 TR = ECOPACK<sup>®</sup> package, tape & reel

- The 28-pin SOIC package (SOH28) requires the SNAPHAT<sup>®</sup> battery/crystal package which is ordered separately under the part number "M4TXX-BR12SHX" in plastic tube or "M4Txx-BR12SHXTR" in tape & reel form (see [Table 19](#)).
- The SOX28 package includes an embedded 32,768 Hz crystal.

**Caution:** Do not place the SNAPHAT<sup>®</sup> battery package "M4Txx-BR12SH" in conductive foam as it will drain the lithium button-cell battery.

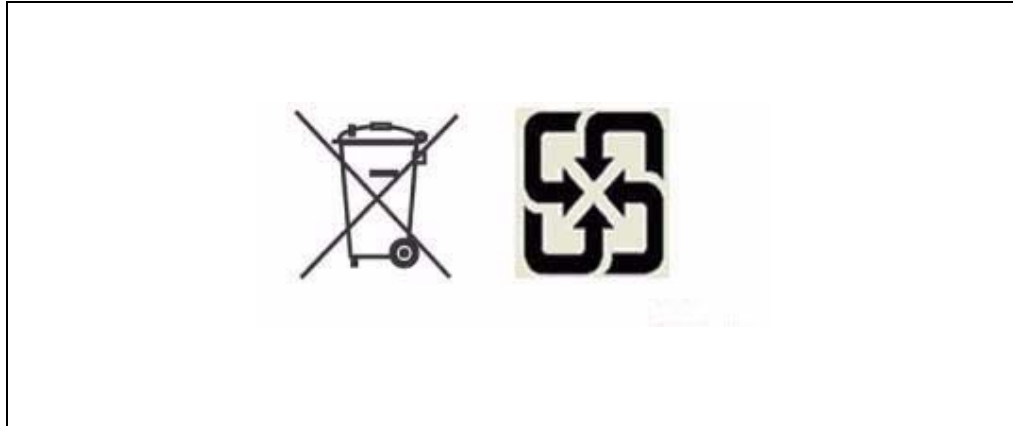
For other options, or for more information on any aspect of this device, please contact the ST sales office nearest you.

**Table 19. SNAPHAT<sup>®</sup> battery/crystal table**

Part number	Description	Package
M4T28-BR12SH	Lithium battery (48 mAh) and crystal SNAPHAT <sup>®</sup> top	SH
M4T32-BR12SH	Lithium battery (120 mAh) and crystal SNAPHAT <sup>®</sup> top	SH

## 8 Environmental information

Figure 25. Recycling symbols



This product contains a non-rechargeable lithium (lithium carbon monofluoride chemistry) button cell battery fully encapsulated in the final product.

Recycle or dispose of batteries in accordance with the battery manufacturer's instructions and local/national disposal and recycling regulations.

Please refer to the following web site address for additional information regarding compliance statements and waste recycling.

Go to [www.st.com/rtc](http://www.st.com/rtc), then select "Lithium Battery Recycling" from "Related Topics".

## 9 Revision history

**Table 20. Document revision history**

Date	Revision	Changes
Aug-2000	1	First issue
24-Aug-2000	1.1	Block Diagram added ( <a href="#">Figure 4</a> )
12-Oct-2000	1.2	$t_{rec}$ Table removed, cross references corrected
18-Dec-2000	2	Reformatted, TOC added, and PFI Input Leakage Current added ( <a href="#">Table 11</a> )
18-Jun-2001	2.1	Addition of $t_{rec}$ information, table changed, one added ( <a href="#">Table 2, 6</a> ); changed PFI/PFO graphic (see <a href="#">Figure 4</a> ); change to DC and AC Characteristics, Order Information ( <a href="#">Table 11, 12, 18</a> ); note added to "Setting Alarm Clock Registers" section; added temp./voltage info. to tables ( <a href="#">Table 10, 11, 6, 12, 13</a> ); addition of Default Values ( <a href="#">Table 7</a> )
22-Jun-2001	2.2	Note added to Clock Operation section
26-Jul-2001	3	Change in Product Maturity
07-Aug-2001	3.1	Improve text in "Setting the Alarm Clock" section
20-Aug-2001	3.2	Change $V_{PFD}$ values in document
06-Sep-2001	3.3	DC Characteristics $V_{BAT}$ changed; $V_{OHB}$ changed; PFI Hysteresis (PFI Rising) spec. added; and Crystal Electrical Characteristics table removed ( <a href="#">Table 11, 6</a> )
03-Dec-2001	3.4	Changed READ/WRITE Mode Sequences ( <a href="#">Figure 10, 12</a> ); change in $V_{PFD}$ lower limit for 5V (M41ST85Y) part only ( <a href="#">Table 11, 18</a> )
01-May-2002	3.5	Change $t_{rec}$ Definition ( <a href="#">Table 6</a> ); modify reflow time and temperature footnote ( <a href="#">Table 8</a> )
03-Jul-2002	3.6	Modify DC Characteristics table footnote, Default Values ( <a href="#">Table 11, 7</a> )
15-Nov-2002	3.7	Added embedded crystal (MX) package option; corrected initial power-up condition (cover page, <a href="#">Figure 1, 3, 4, 5, 24, Table 1, 7, 18,</a> )
24-Jan-2003	3.8	Update diagrams ( <a href="#">Figure 4, 5, 24</a> ); update values ( <a href="#">Table 13, 5, 6, 7,</a> )
25-Feb20-03	4	New Si changes ( <a href="#">Table 13, 5, 6</a> ); corrected dimensions ( <a href="#">Figure 24; Table</a> )
20-May-2004	5	Reformatted; correct dimensions; update Lead-free information ( <a href="#">Figure 20, 13, 16; Table 8, 16, 18</a> )
15-Jun-2004	6	Update characteristics; add package shipping ( <a href="#">Figure 3; Table 1, 11, 18</a> )
13-Sep-2004	7	Update Maximum ratings ( <a href="#">Table 8</a> )
10-Jan-2006	8	Updated template, Lead-free text, removed 5V references ( <a href="#">Figure 1, 2, 3, 4, 5; Table 5, 8, 9, 11, 12, 13, 18, 19</a> )
03-Oct-2007	9	Reformatted document, some text changes; added lead-free second level interconnect information to cover page and <a href="#">Section 6: Package mechanical data</a> ; updated <a href="#">Table 8</a> .
16-Dec-2008	10	Added <a href="#">Section 8: Environmental information</a> ; updated <a href="#">Table 8, Section 6: Package mechanical data</a> ; minor reformatting.



**Please Read Carefully:**

Information in this document is provided solely in connection with ST products. STMicroelectronics NV and its subsidiaries ("ST") reserve the right to make changes, corrections, modifications or improvements, to this document, and the products and services described herein at any time, without notice.

All ST products are sold pursuant to ST's terms and conditions of sale.

Purchasers are solely responsible for the choice, selection and use of the ST products and services described herein, and ST assumes no liability whatsoever relating to the choice, selection or use of the ST products and services described herein.

No license, express or implied, by estoppel or otherwise, to any intellectual property rights is granted under this document. If any part of this document refers to any third party products or services it shall not be deemed a license grant by ST for the use of such third party products or services, or any intellectual property contained therein or considered as a warranty covering the use in any manner whatsoever of such third party products or services or any intellectual property contained therein.

**UNLESS OTHERWISE SET FORTH IN ST'S TERMS AND CONDITIONS OF SALE ST DISCLAIMS ANY EXPRESS OR IMPLIED WARRANTY WITH RESPECT TO THE USE AND/OR SALE OF ST PRODUCTS INCLUDING WITHOUT LIMITATION IMPLIED WARRANTIES OF MERCHANTABILITY, FITNESS FOR A PARTICULAR PURPOSE (AND THEIR EQUIVALENTS UNDER THE LAWS OF ANY JURISDICTION), OR INFRINGEMENT OF ANY PATENT, COPYRIGHT OR OTHER INTELLECTUAL PROPERTY RIGHT.**

**UNLESS EXPRESSLY APPROVED IN WRITING BY AN AUTHORIZED ST REPRESENTATIVE, ST PRODUCTS ARE NOT RECOMMENDED, AUTHORIZED OR WARRANTED FOR USE IN MILITARY, AIR CRAFT, SPACE, LIFE SAVING, OR LIFE SUSTAINING APPLICATIONS, NOR IN PRODUCTS OR SYSTEMS WHERE FAILURE OR MALFUNCTION MAY RESULT IN PERSONAL INJURY, DEATH, OR SEVERE PROPERTY OR ENVIRONMENTAL DAMAGE. ST PRODUCTS WHICH ARE NOT SPECIFIED AS "AUTOMOTIVE GRADE" MAY ONLY BE USED IN AUTOMOTIVE APPLICATIONS AT USER'S OWN RISK.**

Resale of ST products with provisions different from the statements and/or technical features set forth in this document shall immediately void any warranty granted by ST for the ST product or service described herein and shall not create or extend in any manner whatsoever, any liability of ST.

ST and the ST logo are trademarks or registered trademarks of ST in various countries.

Information in this document supersedes and replaces all information previously supplied.

The ST logo is a registered trademark of STMicroelectronics. All other names are the property of their respective owners.

© 2008 STMicroelectronics - All rights reserved

STMicroelectronics group of companies

Australia - Belgium - Brazil - Canada - China - Czech Republic - Finland - France - Germany - Hong Kong - India - Israel - Italy - Japan - Malaysia - Malta - Morocco - Singapore - Spain - Sweden - Switzerland - United Kingdom - United States of America

[www.st.com](http://www.st.com)

