

**+/-15kV ESD Protected, +3V to +5.5V,
1Microamp, 250kbps, EIA/TIA-562,
EIA/TIA-232 Transmitters/Receivers**

The Intersil ISL8563E contains 3.0V to 5.5V powered transmitters/receivers which meet EIA/TIA-562 and EIA/TIA-232 specifications, even at $V_{CC} = 3.0V$. Additionally, they provide $\pm 15kV$ ESD protection (IEC61000-4-2 Air Gap and Human Body Model) on transmitter outputs and receiver inputs (RS-562 pins). Targeted applications are PDAs, Palmtops, and notebook and laptop computers where the low operational, and even lower standby, power consumption is critical. Efficient on-chip charge pumps, coupled with a manual powerdown function, reduce the standby supply current to a $1\mu A$ trickle. Small footprint packaging, and the use of small, low value capacitors ensure board space savings as well. Data rates greater than 250kbps are guaranteed at worst case load conditions. The ISL8563E is fully compatible with 3.3V only systems, mixed 3.3V and 5.0V systems, and 5.0V only systems.

This product features an improved charge pump which delivers $\pm 5V$ transmitter supplies, allowing the use of the ISL8563E in RS-562 and RS-232 applications. RS-562 applications will benefit from the improved noise immunity afforded by the $\pm 5V$ output swing capability.

Table 1 summarizes the features of the device represented by this data sheet, while Application Note AN9863 summarizes the features of each device comprising the 3V RS-232 family.

Ordering Information

PART NO.	TEMP. RANGE (°C)	PACKAGE	PKG. DWG. #
ISL8563ECB	0 to 70	18 Ld SOIC	M18.3
ISL8563ECB-T	0 to 70	Tape and Reel	M18.3

Features

- ESD Protection for RS-562 I/O Pins to $\pm 15kV$ (IEC61000)
- Drop in Replacement for MAX563, with Improved Output Voltage ($\pm 5V$) for Enhanced Noise Immunity
- Meets EIA/TIA-562, and EIA/TIA-232 Specifications at 3V
- RS-232 Compatible Outputs at 2.7V
- Latch-Up Free
- On-Chip Voltage Converters Require Only Four External $0.1\mu F$ Capacitors
- Receivers Active in Powerdown
- Receiver Hysteresis For Improved Noise Immunity
- Guaranteed Minimum Data Rate 250kbps
- Guaranteed Minimum Slew Rate $4V/\mu s$
- Wide Power Supply Range Single +3V to +5.5V
- Low Supply Current in Powerdown State. $1\mu A$

Applications

- Any System Requiring RS-562/RS-232 Communication Ports
 - Battery Powered, Hand-Held, and Portable Equipment
 - Laptop Computers, Notebooks, Palmtops
 - Digital Cameras
 - Bar Code Readers

Related Literature

- Technical Brief TB363 "Guidelines for Handling and Processing Moisture Sensitive Surface Mount Devices (SMDs)"
- Application Note AN9863, "3V to +5.5V, 250K-1Mbps, RS-232 Transmitters/Receivers"

Pinout

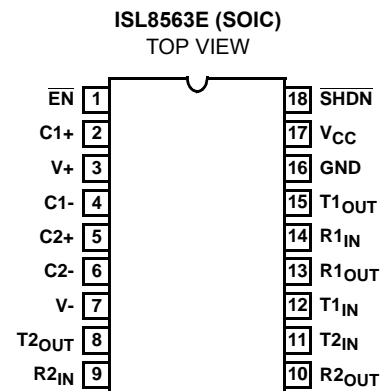

ISL8563E

TABLE 1. SUMMARY OF FEATURES

PART NUMBER	NO. OF Tx.	NO. OF Rx.	NO. OF MONITOR Rx. (ROUTB)	DATA RATE (kbps)	Rx. ENABLE FUNCTION?	READY OUTPUT?	MANUAL POWER-DOWN?	AUTOMATIC POWERDOWN FUNCTION?
ISL8563E	2	2	0	250	Yes	No	Yes	No

Pin Descriptions

PIN	FUNCTION
V _{CC}	System Power Supply Input (3.0V to 5.5V).
V+	Internally Generated Positive Transmitter Supply (+5.5V).
V-	Internally Generated Negative Transmitter Supply (-5.5V).
GND	Ground Connection.
C1+	External Capacitor (Voltage Doubler) is connected to this lead.
C1-	External Capacitor (Voltage Doubler) is connected to this lead.
C2+	External Capacitor (Voltage Inverter) is connected to this lead.
C2-	External Capacitor (Voltage Inverter) is connected to this lead.
T _{IN}	TTL/CMOS Compatible Transmitter Inputs with pull-up resistors.
T _{OUT}	±15kV ESD Protected, RS-562/RS-232 level (nominally ±5.5V) transmitter outputs.
R _{IN}	±15kV ESD Protected, RS-562/RS-232 compatible receiver inputs.
R _{OUT}	TTL/CMOS Level Receiver Outputs.
$\overline{\text{EN}}$	Active Low Receiver Enable Control.
$\overline{\text{SHDN}}$	Active Low Input which shuts down transmitters and on-board power supply, to place device in low power mode.

Typical Operating Circuit

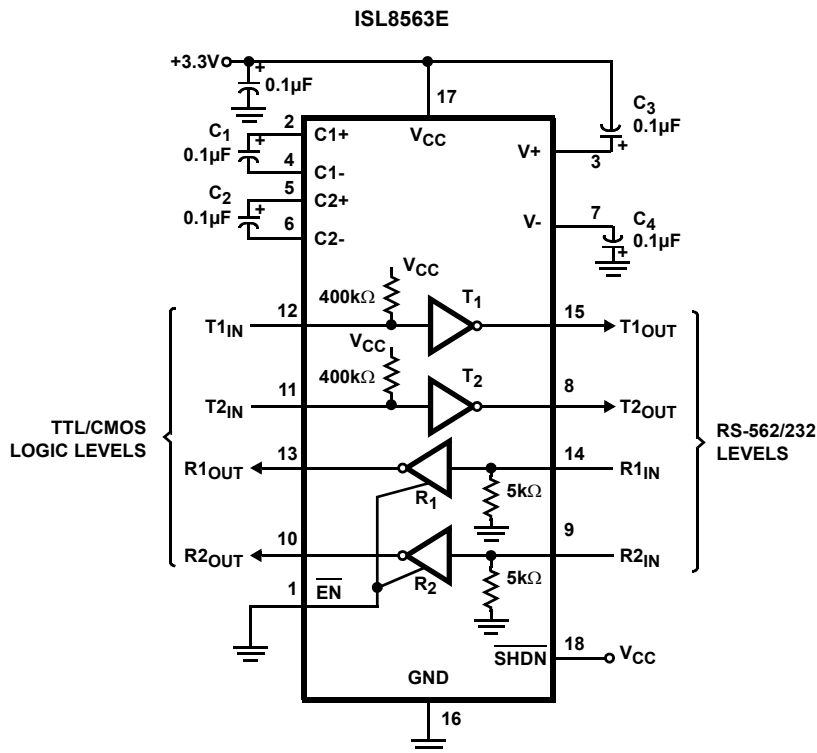

Absolute Maximum Ratings

V _{CC} to Ground	-0.3V to 6V
V+ to Ground	-0.3V to 7V
V- to Ground	+0.3V to -7V
V+ to V-	14V
Input Voltages	
T _{IN} , EN, SHDN	-0.3V to 6V
R _{IN}	±25V
Output Voltages	
T _{OUT}	±13.2V
R _{OUT}	-0.3V to V _{CC} +0.3V
Short Circuit Duration	
T _{OUT}	Continuous
ESD Rating	See Specification Table

Thermal Information

Thermal Resistance (Typical, Note 1)	θ _{JA} (°C/W)
18 Ld SOIC Package	75
Maximum Junction Temperature (Plastic Package)	150°C
Maximum Storage Temperature Range	-65°C to 150°C
Maximum Lead Temperature (Soldering 10s) (Lead Tips Only)	300°C

Operating Conditions

Temperature Range	ISL8563ECX	0°C to 70°C
-------------------	------------	-------------

CAUTION: Stresses above those listed in "Absolute Maximum Ratings" may cause permanent damage to the device. This is a stress only rating and operation of the device at these or any other conditions above those indicated in the operational sections of this specification is not implied.

NOTE:

1. θ_{JA} is measured with the component mounted on a low effective thermal conductivity test board in free air. See Tech Brief TB379 for details.

Electrical Specifications Test Conditions: V_{CC} = 3V to 5.5V, C₁ - C₄ = 0.1µF; Unless Otherwise Specified.
Typicals are at T_A = 25°C

PARAMETER	TEST CONDITIONS	TEMP (°C)	MIN	TYP	MAX	UNITS
RS-562/RS-232 TRANSMITTERS						
Output Voltage Swing	All Transmitter Outputs Loaded with 3kΩ to Ground	Full	±5.0	±5.4	-	V
Maximum Data Rate	R _L = 3kΩ, C _L = 1000pF, One Transmitter Switching and Maintaining ±5V Output Swing	Full	250	500	-	kbps
Input Logic Threshold Low	T _{IN}	Full	-	-	0.8	V
Input Logic Threshold High	T _{IN} V _{CC} = 3.0V to 5.0V	Full	2.4	-	-	V
Transmitter Pull-Up Input Current	T _{IN} SHDN = V _{CC}	Full	-	2	20	µA
	T _{IN} SHDN = GND	Full	-	±0.01	±1.0	µA
Output Leakage Current	V _{OUT} = ±12V, V _{CC} = 0V or 3.6V to 5.5V, SHDN = GND	Full	-	-	±10	µA
Output Resistance	V _{CC} = V+ = V- = 0V, Transmitter Output = ±2V	Full	300	10M	-	Ω
Output Short-Circuit Current	V _{OUT} = 0V	Full	-	±35	±60	mA
RS-562/RS-232 RECEIVERS						
Input Voltage Range		Full	-25	-	25	V
Input Threshold Low	V _{CC} = 3.3V	Full	-	1.2	0.6	V
	V _{CC} = 5.0V	Full	-	1.5	0.8	V
Input Threshold High	V _{CC} = 3.3V	Full	2.4	1.5	-	V
	V _{CC} = 5.0V	Full	2.4	1.8	-	V
Input Hysteresis	V _{CC} = 3.0V to 3.6V	Full	0.1	0.5	1.0	V
Input Resistance		Full	3	5	7	kΩ
Output Voltage Low	I _{OUT} = 3.2mA	Full	-	-	0.4	V
Output Voltage High	I _{OUT} = -1.0mA	Full	V _{CC} -0.6	V _{CC} -0.1	-	V
Output Leakage Current	EN = V _{CC}	Full	-	±0.05	±10	µA
EN Input Logic Threshold Low		Full	-	-	0.8	V
EN Input Logic Threshold High	V _{CC} = 3.0V to 5.0V	Full	2.4	-	-	V
POWER SUPPLY						
Operating Supply Voltage		Full	3.0	-	5.5	V
Supply Current	SHDN = V _{CC} All Outputs Unloaded	Full	-	0.5	6.0	mA
	SHDN = V _{CC} All Outputs loaded, R _L = 3kΩ	25	-	14	-	mA

Electrical Specifications Test Conditions: $V_{CC} = 3V$ to $5.5V$, $C_1 - C_4 = 0.1\mu F$; Unless Otherwise Specified.
Typicals are at $T_A = 25^\circ C$ (Continued)

PARAMETER	TEST CONDITIONS	TEMP (°C)	MIN	TYP	MAX	UNITS	
Supply Current, Powerdown	SHDN = GND	25	-	1	10	μA	
		Full	-	1	25	μA	
SHDN Input Leakage Current		Full	-	± 0.01	± 1.0	μA	
SHDN Input Logic Threshold Low		Full	-	-	0.8	V	
SHDN Input Logic Threshold High	$V_{CC} = 3.0V$ to $5.0V$	Full	2.4	-	-	V	
AC CHARACTERISTICS							
Transition Region Slew Rate	$V_{CC} = 3.3V$, $R_L = 3k\Omega$ to $7k\Omega$, Measured From $3V$ to $-3V$ or $-3V$ to $3V$, $C_L = 50pF$ to $2500pF$	25	4	-	30	$V/\mu s$	
Transmitter Propagation Delay	Transmitter Input to Transmitter Output, $C_L = 1000pF$, $R_L = 3k\Omega$	t_{PHL} (Note 2)	Full	-	1	3.5	μs
		t_{PLH} (Note 2)	Full	-	1	3.5	μs
Receiver Propagation Delay	Receiver Input to Receiver Output, $C_L = 150pF$	t_{PHL} (Note 3)	Full	-	0.3	1.0	μs
		t_{PLH} (Note 3)	Full	-	0.3	1.0	μs
Receiver Output Enable Time	Figure 1		Full	-	125	500	ns
Receiver Output Disable Time	Figure 1		Full	-	160	500	ns
Transmitter Output Enable Time	Figure 2		25	-	17	-	μs
Transmitter Output Disable Time	Figure 2		25	-	600	-	ns
Transmitter Skew	$t_{PHL} - t_{PLH}$ (Note 2)	25	-	100	-	ns	
Receiver Skew	$t_{PHL} - t_{PLH}$ (Note 3)	25	-	100	-	ns	
ESD PERFORMANCE							
RS-562 Pins (T_{OUT} , R_{IN})	Human Body Model	25	-	± 15	-	kV	
	IEC61000-4-2 Contact Discharge	25	-	± 8	-	kV	
	IEC61000-4-2 Air Gap Discharge	25	-	± 15	-	kV	
All Other Pins	Human Body Model	25	-	± 3	-	kV	

NOTES:

2. Transmitter is measured at the transmitter zero crossing points.
3. Receiver is measured at the receiver 50 percent crossing points.

Test Waveforms

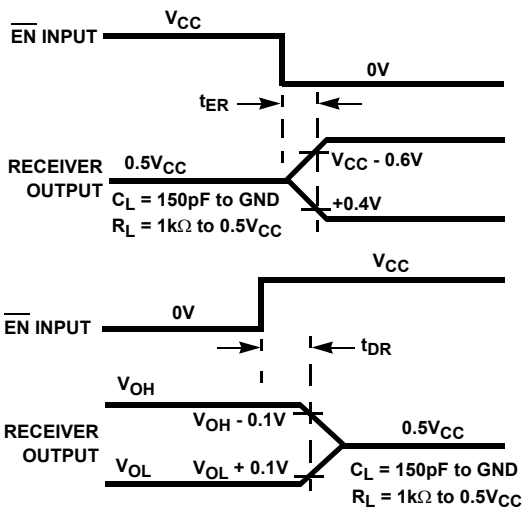

FIGURE 1. RECEIVER OUTPUT ENABLE AND DISABLE TIMING

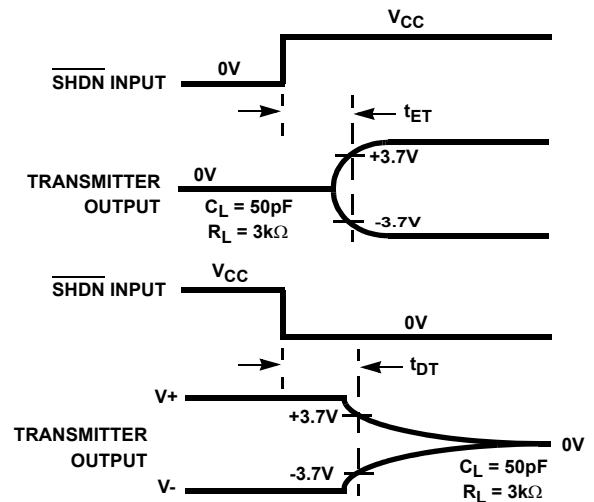

FIGURE 2. TRANSMITTER OUTPUT ENABLE AND DISABLE TIMING

Detailed Description

The ISL8563E operates from a single +3V to +5.5V supply, guarantees a 250kbps minimum data rate, requires only four small external 0.1 μ F capacitors, features low power consumption, and meets all EIA/TIA-562 and EIA/TIA-232 specifications. The circuit is divided into three sections: The charge pump, the transmitters, and the receivers.

Charge-Pump

Intersil's new ISL8563E utilizes regulated on-chip dual charge pumps as voltage doublers, and voltage inverters to generate $\pm 5.5V$ transmitter supplies from a V_{CC} supply as low as 3.0V. This allows these devices to maintain RS-232 compliant output levels over the $\pm 10\%$ tolerance range of 3.3V powered systems. The efficient on-chip power supplies require only four small, external 0.1 μ F capacitors for the voltage doubler and inverter functions over the full V_{CC} range. The charge pumps operate discontinuously (i.e., they turn off as soon as the V+ and V- supplies are pumped up to the nominal values), resulting in significant power savings.

Transmitters

The transmitters are proprietary, low dropout, inverting drivers that translate TTL/CMOS inputs to EIA/TIA-562/232 output levels. Coupled with the on-chip $\pm 5.5V$ supplies, these transmitters deliver true RS-562/232 levels over a wide range of single supply system voltages.

All transmitter outputs disable and assume a high impedance state when the device enters the powerdown mode (see Table 2). These outputs may be driven to $\pm 12V$ when disabled.

All devices guarantee a 250kbps data rate ($V_{OUT} = \pm 5V$) for full load conditions (3k Ω and 1000pF), $V_{CC} \geq 3.0V$, with one transmitter operating at full speed. Under more typical conditions of $V_{CC} \geq 3.3V$, $R_L = 3k\Omega$, and $C_L = 250pF$, one transmitter easily operates at 900kbps.

Unused transmitter inputs may be left unconnected because they will be pulled to V_{CC} by the on-chip pull-up resistors. Forcing the ISL8563E into power down disables the pull-up resistors to further minimize power.

Receivers

The ISL8563E contains standard inverting receivers that three-state via the \overline{EN} control line. All the receivers convert RS-562/232 signals to CMOS output levels and accept inputs up to $\pm 25V$ while presenting the required 3k Ω to 7k Ω input impedance (see Figure 3) even if the power is off

($V_{CC} = 0V$). The receivers' Schmitt trigger input stage uses hysteresis (even in powerdown) to increase noise immunity and decrease errors due to slow input signal transitions.

The ISL8563E inverting receivers disable only when \overline{EN} is driven high. Standard receivers driving powered down peripherals must be disabled to prevent current flow through the peripheral's protection diodes (see Figures 4 and 5).

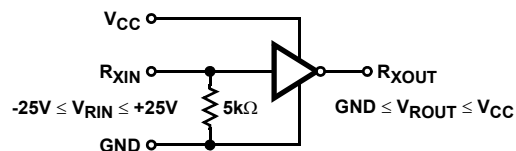

FIGURE 3. INVERTING RECEIVER CONNECTIONS

Powerdown Functionality

This 3V device requires a nominal supply current of 0.3mA during normal operation (not in powerdown mode). This is considerably less than the 5mA to 11mA current required by 5V devices. The already low current requirement drops significantly when the device enters powerdown mode. In powerdown, supply current drops to 1 μ A, because the on-chip charge pump turns off ($V+$ collapses to V_{CC} , $V-$ collapses to GND), the transmitter outputs three-state, and the transmitter input pull-ups disable. This micro-power mode makes the ISL8563E ideal for battery powered and portable applications.

Software Controlled (Manual) Powerdown

The ISL8563E, is forced into its low power, stand by state via a simple shutdown (\overline{SHDN}) pin. Driving this pin high enables normal operation, while driving it low forces the IC into its powerdown state. Connect \overline{SHDN} to V_{CC} if the powerdown function isn't needed. Note that all the receiver outputs remain enabled during shutdown (see Table 2). For the lowest power consumption during powerdown, the receivers should also be disabled by driving the \overline{EN} input high (see next section, and Figures 4 and 5). The time required to exit powerdown, and resume transmission is less than 30 μ s.

Receiver ENABLE Control

The device also features an \overline{EN} input to control the receiver outputs. Driving \overline{EN} high disables all the receiver outputs placing them in a high impedance state. This is useful to eliminate supply current, due to a receiver output forward biasing the protection diode, when driving the input of a powered down ($V_{CC} = GND$) peripheral (see Figure 4). The enable input has no effect on transmitters.

TABLE 2. POWERDOWN AND ENABLE LOGIC TRUTH TABLE

\overline{SHDN} INPUT	\overline{EN} INPUT	TRANSMITTER OUTPUTS	RECEIVER OUTPUTS	MODE OF OPERATION
L	L	High-Z	Active	Manual Powerdown
L	H	High-Z	High-Z	Manual Powerdown w/Rcvr. Disabled
H	L	Active	Active	Normal Operation
H	H	Active	High-Z	Normal Operation w/Rcvr. Disabled

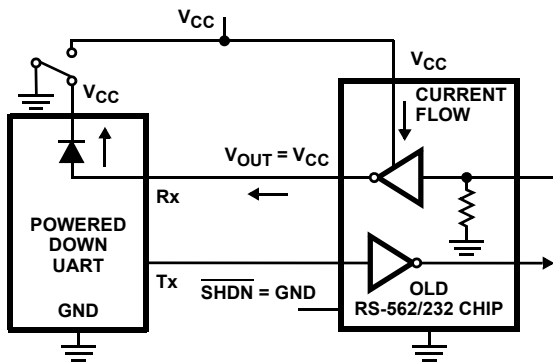

FIGURE 4. POWER DRAIN THROUGH POWERED DOWN PERIPHERAL

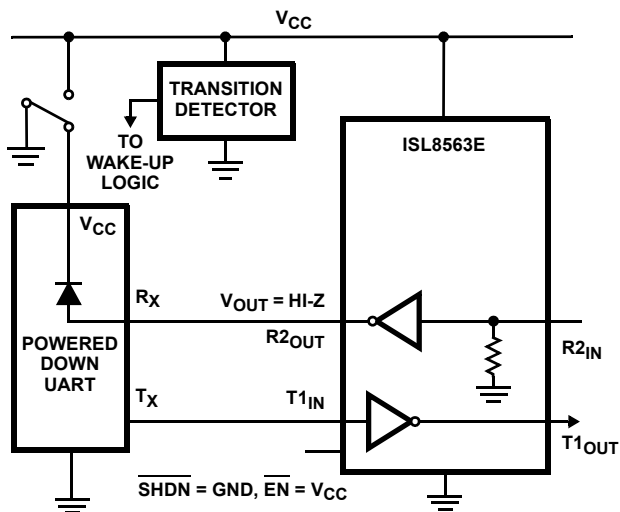

FIGURE 5. DISABLED RECEIVERS PREVENT POWER DRAIN

Capacitor Selection

The charge pumps operate with 0.1 μ F (or greater) capacitors for $3.0V \leq V_{CC} \leq 5.5V$. Increasing the capacitor values (by a factor of 2) reduces ripple on the transmitter outputs and slightly reduces power consumption. C_2 , C_3 , and C_4 can be increased without increasing C_1 's value, however, do not increase C_1 without also increasing C_2 , C_3 , and C_4 to maintain the proper ratios (C_1 to the other capacitors).

When using minimum required capacitor values, make sure that capacitor values do not degrade excessively with temperature. If in doubt, use capacitors with a larger nominal value. The capacitor's equivalent series resistance (ESR) usually rises at low temperatures and it influences the amount of ripple on $V+$ and $V-$.

Power Supply Decoupling

In most circumstances a 0.1 μ F bypass capacitor is adequate. In applications that are particularly sensitive to power supply noise, decouple V_{CC} to ground with a capacitor of the same value as the charge-pump capacitor C_1 . Connect the bypass capacitor as close as possible to the IC.

Operation Down to 2.7V

ISL8563E transmitter outputs meet RS-562 levels ($\pm 3.7V$), at the full data rate, with V_{CC} as low as 2.7V. RS-562 levels typically ensure interoperability with RS-232 devices.

Transmitter Outputs When Exiting Powerdown

Figure 6 shows the response of two transmitter outputs when exiting powerdown mode. As they activate, the two transmitter outputs properly go to opposite RS-562/232 levels, with no glitching, ringing, nor undesirable transients. Each transmitter is loaded with 3k Ω in parallel with 2500pF. Note that the transmitters enable only when the magnitude of the supplies exceed approximately 3V.

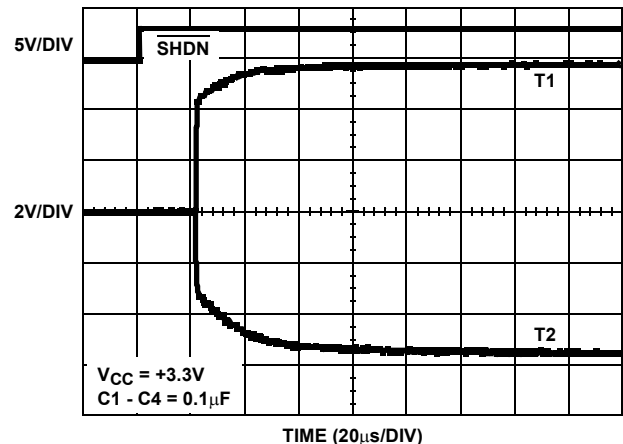

FIGURE 6. TRANSMITTER OUTPUTS WHEN EXITING POWERDOWN

High Data Rates

The ISL8563E maintains the RS-232 $\pm 5V$ minimum transmitter output voltages even at high data rates. Figure 7 details a transmitter loopback test circuit, and Figure 8 illustrates the loopback test result at 120kbps. For this test, all transmitters were simultaneously driving RS-232 loads in parallel with 1000pF, at 120kbps. Figure 9 shows the loopback results for a single transmitter driving 1000pF and an RS-232 load at 250kbps. The static transmitters were also loaded with an RS-232 receiver.

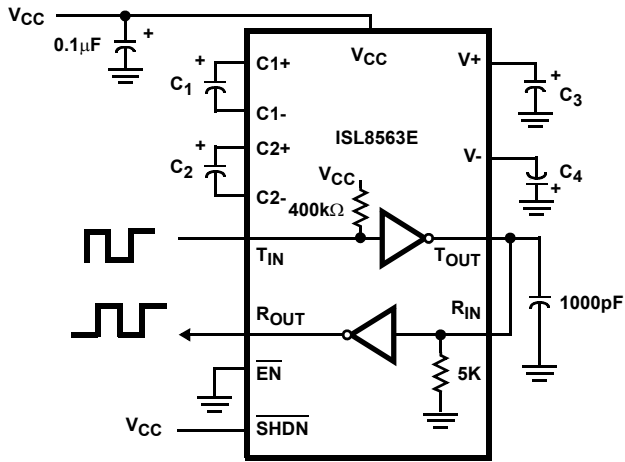

FIGURE 7. TRANSMITTER LOOPBACK TEST CIRCUIT

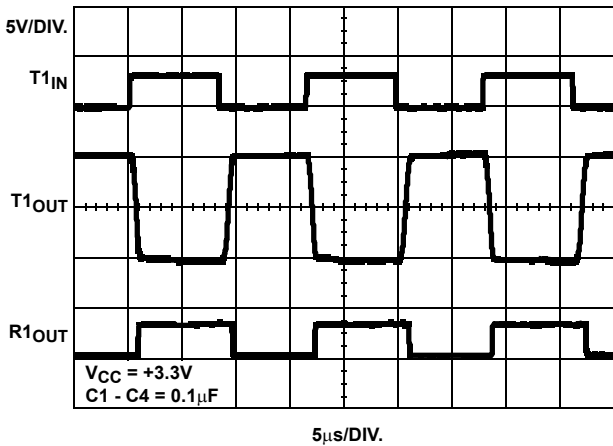

FIGURE 8. LOOPBACK TEST AT 120kbps

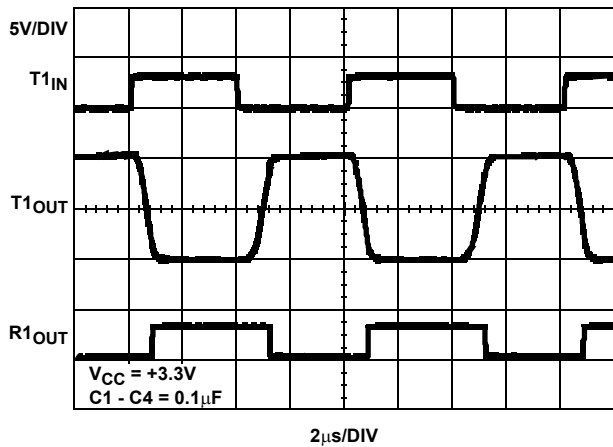

FIGURE 9. LOOPBACK TEST AT 250kbps

Interconnection with 3V and 5V Logic

The ISL8563E directly interfaces with 5V CMOS and TTL logic families. Nevertheless, with the device at 3.3V, and the logic supply at 5V, AC, HC, and CD4000 outputs can drive ISL83563E inputs, but ISL83563E outputs do not reach the minimum V_{IH} for these logic families. See Table 3 for more information.

TABLE 3. LOGIC FAMILY COMPATIBILITY WITH VARIOUS SUPPLY VOLTAGES

SYSTEM POWER-SUPPLY VOLTAGE (V)	V _{CC} SUPPLY VOLTAGE (V)	COMPATIBILITY
3.3	3.3	Compatible with all CMOS families.
5	5	Compatible with all TTL and CMOS logic families.
5	3.3	Compatible with ACT and HCT CMOS, and with TTL. ISL83563E outputs are incompatible with AC, HC, and CD4000 CMOS inputs.

±15kV ESD Protection

All pins on Intersil 3V interface devices include ESD protection structures, but the ISL8XXXE family incorporates advanced structures which allow the RS-562/232 pins (transmitter outputs and receiver inputs) to survive ESD events up to ±15kV. These pins are particularly vulnerable to ESD damage because they typically connect to an exposed port on the exterior of the finished product. Simply touching the port pins, or connecting a cable, can cause an ESD event that might destroy unprotected ICs. These new ESD structures protect the device whether or not it is powered up, protect without allowing any latchup mechanism to activate, and don't interfere with RS-562/232 signals as large as ±25V.

Human Body Model (HBM) Testing

As the name implies, this test method emulates the ESD event delivered to an IC during human handling. The tester delivers the charge through a 1.5kΩ current limiting resistor, making the test less severe than the IEC61000 test which utilizes a 330Ω limiting resistor. The HBM method determines an ICs ability to withstand the ESD transients typically present during handling and manufacturing. Due to the random nature of these events, each pin is tested with respect to all other pins. The RS-562/232 pins on "E" family devices can withstand HBM ESD events to ±15kV.

IEC61000-4-2 Testing

The IEC61000 test method applies to finished equipment, rather than to an individual IC. Therefore, the pins most likely to suffer an ESD event are those that are exposed to the outside world (the RS-562/232 pins in this case), and the IC is tested in its typical application configuration (power applied) rather than testing each pin-to-pin combination. The lower current limiting resistor coupled with the larger charge

storage capacitor yields a test that is much more severe than the HBM test. The extra ESD protection built into this device's RS-562/232 pins allows the design of equipment meeting level 4 criteria without the need for additional board level protection on the RS-562/232 port.

AIR-GAP DISCHARGE TEST METHOD

For this test method, a charged probe tip moves toward the IC pin until the voltage arcs to it. The current waveform delivered to the IC pin depends on approach speed, humidity, temperature, etc., so it is difficult to obtain

repeatable results. The "E" device RS-562/232 pins withstand ±15kV air-gap discharges.

CONTACT DISCHARGE TEST METHOD

During the contact discharge test, the probe contacts the tested pin before the probe tip is energized, thereby eliminating the variables associated with the air-gap discharge. The result is a more repeatable and predictable test, but equipment limits prevent testing devices at voltages higher than ±8kV. All "E" family devices survive ±8kV contact discharges on the RS-562/232 pins.

Typical Performance Curves $V_{CC} = 3.3V, T_A = 25^\circ C$

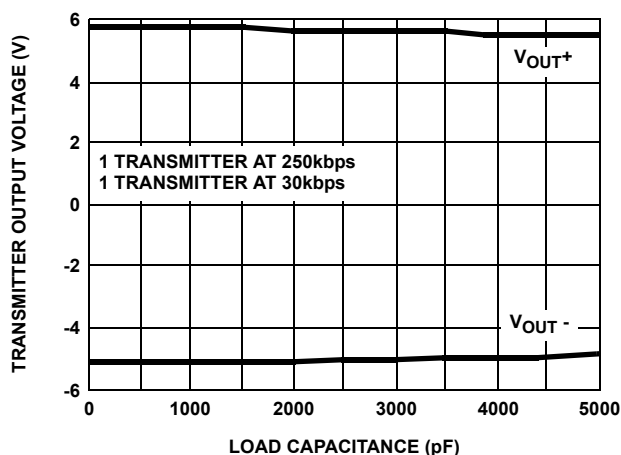

FIGURE 10. TRANSMITTER OUTPUT VOLTAGE vs LOAD CAPACITANCE

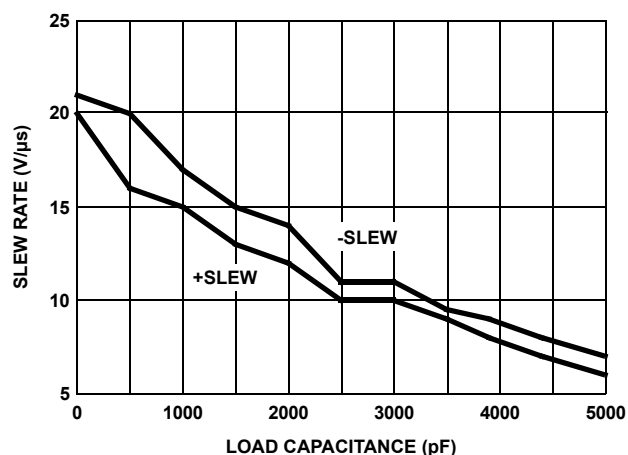

FIGURE 11. SLEW RATE vs LOAD CAPACITANCE

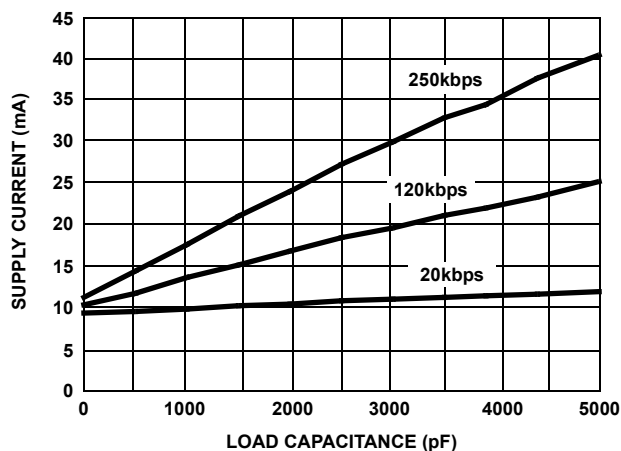

FIGURE 12. SUPPLY CURRENT vs LOAD CAPACITANCE WHEN TRANSMITTING DATA

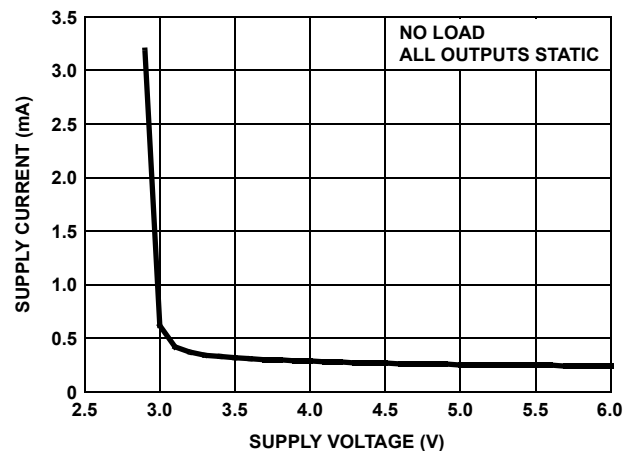

FIGURE 13. SUPPLY CURRENT vs SUPPLY VOLTAGE

Die Characteristics

SUBSTRATE POTENTIAL (POWERED UP):

GND

PROCESS:

Si Gate CMOS

TRANSISTOR COUNT:

338

Small Outline Plastic Packages (SOIC)

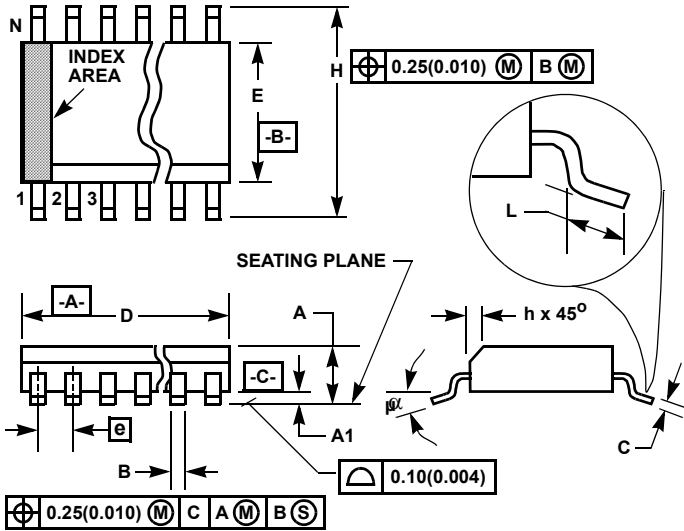

M18.3 (JEDEC MS-013-AB ISSUE C)
18 LEAD WIDE BODY SMALL OUTLINE PLASTIC PACKAGE

SYMBOL	INCHES		MILLIMETERS		NOTES
	MIN	MAX	MIN	MAX	
A	0.0926	0.1043	2.35	2.65	-
A1	0.0040	0.0118	0.10	0.30	-
B	0.013	0.0200	0.33	0.51	9
C	0.0091	0.0125	0.23	0.32	-
D	0.4469	0.4625	11.35	11.75	3
E	0.2914	0.2992	7.40	7.60	4
e	0.050 BSC		1.27 BSC		-
H	0.394	0.419	10.00	10.65	-
h	0.010	0.029	0.25	0.75	5
L	0.016	0.050	0.40	1.27	6
N	18		18		7
α	0°	8°	0°	8°	-

NOTES:

1. Symbols are defined in the "MO Series Symbol List" in Section 2.2 of Publication Number 95.
2. Dimensioning and tolerancing per ANSI Y14.5M-1982.
3. Dimension "D" does not include mold flash, protrusions or gate burrs. Mold flash, protrusion and gate burrs shall not exceed 0.15mm (0.006 inch) per side.
4. Dimension "E" does not include interlead flash or protrusions. Interlead flash and protrusions shall not exceed 0.25mm (0.010 inch) per side.
5. The chamfer on the body is optional. If it is not present, a visual index feature must be located within the crosshatched area.
6. "L" is the length of terminal for soldering to a substrate.
7. "N" is the number of terminal positions.
8. Terminal numbers are shown for reference only.
9. The lead width "B", as measured 0.36mm (0.014 inch) or greater above the seating plane, shall not exceed a maximum value of 0.61mm (0.024 inch)
10. Controlling dimension: MILLIMETER. Converted inch dimensions are not necessarily exact.

Rev. 0 12/93

All Intersil U.S. products are manufactured, assembled and tested utilizing ISO9000 quality systems.
 Intersil Corporation's quality certifications can be viewed at www.intersil.com/design/quality

Intersil products are sold by description only. Intersil Corporation reserves the right to make changes in circuit design, software and/or specifications at any time without notice. Accordingly, the reader is cautioned to verify that data sheets are current before placing orders. Information furnished by Intersil is believed to be accurate and reliable. However, no responsibility is assumed by Intersil or its subsidiaries for its use; nor for any infringements of patents or other rights of third parties which may result from its use. No license is granted by implication or otherwise under any patent or patent rights of Intersil or its subsidiaries.

For information regarding Intersil Corporation and its products, see www.intersil.com