

### FEATURES

- Single chip primary rate transceiver meets CCITT standards G.704, G.706 and G.732
- Supports new CRC4-based framing standards and CAS and CCS signaling standards
- Simple serial interface used for device configuration and control in processor mode
- Hardware mode requires no host processor; intended for stand-alone applications
- Comprehensive, on-chip alarm generation, alarm detection, and error logging logic
- Shares footprint with DS2180A T1 Transceiver
- Comparison to DS2175 T1/CEPT Elastic Store, DS2186 Transmit Line Interface, DS2187 Receive Line Interface, and DS2188 Jitter Attenuator
- 5V supply; low-power CMOS technology

### PIN ASSIGNMENT

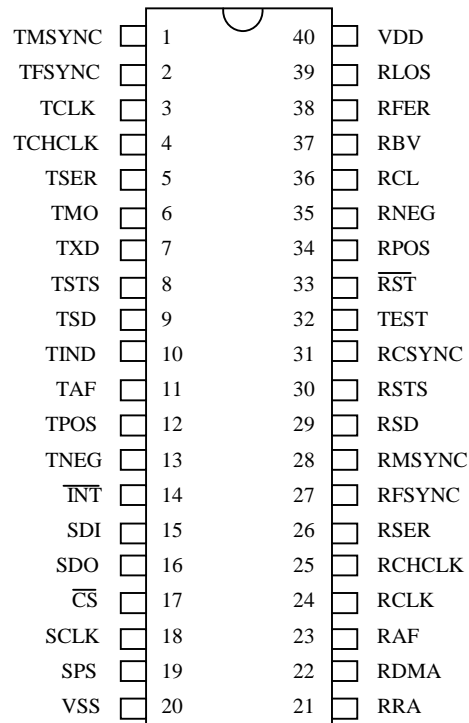

40-Pin DIP (600-mil)

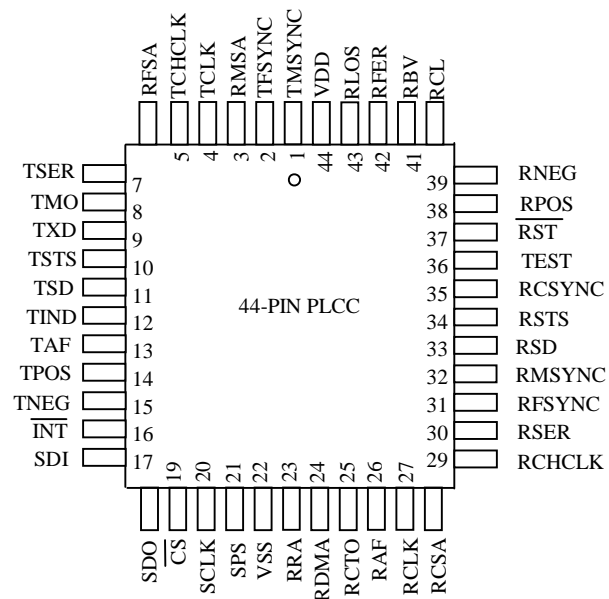

## DESCRIPTION

The DS2181A is designed for use in CEPT networks and supports all logical requirements of CCITT Red Book Recommendations G.704, G.706 and G.732. The transmit side generates framing patterns and CRC4 codes, formats outgoing channel and signaling data, and produces network alarm codes when enabled. The receive side decodes the incoming data and establishes frame, CAS multiframe, and CRC4 multiframe alignments. Once synchronized, the device extracts channel, signaling, and alarm data.

A serial port allows access to 14 on-chip control and status registers in the processor mode. In this mode, a host processor controls features such as error logging, per-channel code manipulation, and alteration of the receive synchronizer algorithm.

The hardware mode is intended for preliminary system prototyping and/or retrofitting into existing systems. This mode requires no host processor and disables special features available in the processor mode.

## DS2180A BLOCK DIAGRAM Figure 1

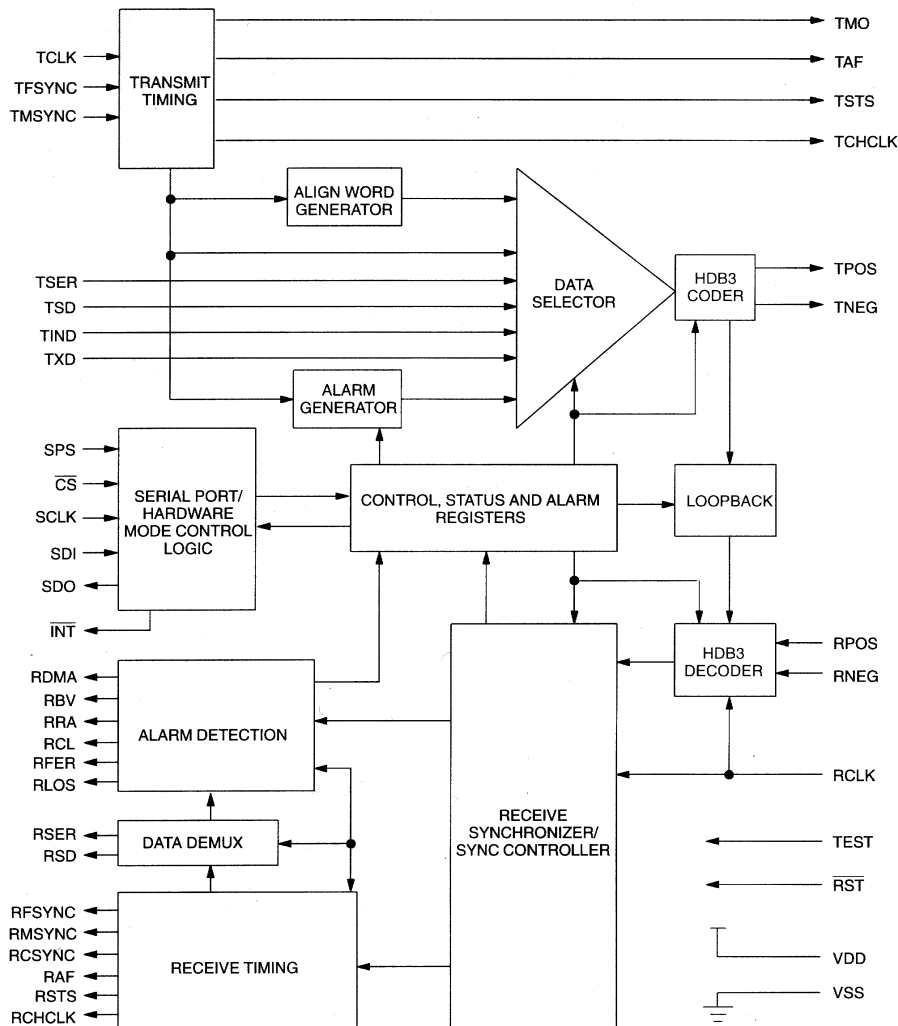

**TRANSMIT PIN DESCRIPTION (40-PIN DIP ONLY) Table 1**

PIN	SYMBOL	TYPE	DESCRIPTION
1	TMSYNC	I	<b>Transmit Multiframe Sync.</b> Low-high transition establishes start of CAS and/or CRC4 multiframe. Can be tied low, allowing internal multiframe counter to run free.
2	TFSYNC	I	<b>Transmit Frame Sync.</b> Low-high transition every frame period establishes frame boundaries. Can be tied low, allowing TMSYNC to establish frame boundaries.
3	TCLK	I	<b>Transmit Clock.</b> 2.048 MHz primary clock.
4	TCHCLK	O	<b>Transmit Channel Clock.</b> 256 kHz clock which identifies timeslot boundaries. Useful for parallel-to-serial conversion of channel data.
5	TSER	I	<b>Transmit Serial Data.</b> NRZ data input, sampled on falling edges of TCLK.
6	TMO	O	<b>Transmit Multiframe Out.</b> Output of multiframe counter; high during frame 0, low otherwise.
7	TXD	I	<b>Transmit Extra Data.</b> Sampled on falling edge of TCLK during bit times 5, 7, and 8 of timeslot 16 in frame 0 when CAS signaling is enabled.
8	TSTS	O	<b>Transmit Signaling Timeslot.</b> High during timeslot 16 of every frame, low otherwise.
9	TSD	I	<b>Transmit Signaling Data.</b> CAS signaling data input; sampled on falling edges of TCLK for insertion into outgoing timeslot 16 when enabled.
10	TIND	I	<b>Transmit International and National Data.</b> Sampled on falling edge of TCLK during bit 1 time of timeslot 0 every frame (international) and/or during bit times 4 through 8 of timeslot 0 during non-align frames (national) when enabled.
11	TAF	O	<b>Transmit Alignment Frame.</b> High during frames containing the frame alignment signal, low otherwise.
12	TPOS	O	<b>Transmit Bipolar Data Outputs.</b> Updated on rising edge of TCLK.
13	TNEG	O	

**SYNCHRONIZER STATUS PIN (44-PIN PLCC ONLY) Table 2A**

PIN	SYMBOL	TYPE	DESCRIPTION
3	RMSA	O	<b>Receive Multiframe Search Active.</b> This pin will transition high when the synchronizer searching for the CAS multiframe alignment word is active.
6	RFSA	O	<b>Receive Frame Search Active.</b> This pin will transition high when the synchronizer searching for the FAS is active.
25	RCTO	O	<b>Receive CRC4 Time Out.</b> This pin will transition high when the RCTO counter reaches its maximum count of 32. The pin will return low when either the DS2181AQ reaches CRC4 multiframe synchronization, or if CRC4 is disabled via CRC.2, or if the device is issued a hardware reset via the $\overline{\text{RST}}$ pin.
28	RCSA	O	<b>Receive CRC4 Search Active.</b> This pin will transition high when the synchronizer searching for the CRC4 multiframe alignment word is active.

**NOTES:**

1. These output status pins are only available on the DS2181AQ.
2. If the TEST pin is tied low and CCR.1=0, then these pins will be tri-stated.

**RECEIVE PIN DESCRIPTION (40-PIN DIP ONLY) Table 2B**

PIN	SYMBOL	TYPE	DESCRIPTION
21	RRA	O	<b>Receive Remote Alarm.</b> Transitions high when alarm detected; returns low when alarm cleared.
22	RMDA	O	<b>Receive Distant Multiframe Alarm.</b> Transitions high when alarm detected; returns low when alarm cleared.
23	RAF	O	<b>Receive Alignment Frame.</b> High during frames containing the frame alignment signal, low otherwise.
24	RCLK	I	<b>Receive Clock.</b> 2.048 MHz primary clock.
25	RCHCLK	O	<b>Receive Channel Clock.</b> 256 kHz clock, identifies timeslot boundaries; useful for serial-to-parallel conversion of channel data.
26	RSER	O	<b>Receive Channel Clock.</b> 256 kHz clock, identifies timeslot boundaries; useful for serial-to-parallel conversion of channel data.
27	RFSYNC	O	<b>Receive Frame Sync.</b> Trailing edge indicates start of frame.
28	RMSYNC	O	<b>Receive Multiframe Sync.</b> Low-high transition indicates start of CAS multiframe; held high during frame 0.
29	RSD	O	<b>Receive Signaling Data.</b> Extracted timeslot 16 data; updated on rising edge of RCLK.
30	RSTS	O	<b>Receive Signaling Timeslot.</b> High during timeslot 16 of every frame, low otherwise.
31	RCSYNC	O	<b>Receive CRC4 Sync.</b> Low-high transition indicates start of CRC4 multiframe; held high during CRC4 frames 0 through 7 and held low during frames 8 through 15.
33	$\overline{\text{RST}}$	I	<b>Reset.</b> Must be asserted during device power-up and when changing to/from the hardware mode.
34	RPOS	I	<b>Receive Bipolar Data.</b> Sampled on falling edges of RCLK. Tie together to receive NRZ data and disable BPV monitor circuitry.
35	RNEG		
36	RCL	O	<b>Receive Carrier Loss.</b> Low-high transition indicates loss of carrier.
37	RBV	O	<b>Receive Bipolar Violation.</b> Pulses high during detected bipolar violations.
38	RFER	O	<b>Receive Frame Error.</b> Pulses high when frame alignment, CAS multiframe alignment or CRC4 words received in error.
39	RLOS	O	<b>Receive Loss of Sync.</b> Indicates synchronizer status; high when frame, CAS and/or CRC4 multiframe search underway, low otherwise.

**PORT PIN DESCRIPTION (40-PIN DIP ONLY) Table 3**

PIN	SYMBOL	TYPE	DESCRIPTION
14	$\overline{\text{INT}}$	O	<b>Receive Alarm Interrupt.</b> Flags host controller during alarm conditions. Active low; open drain output.
15	SDI	I	<b>Serial Data In.</b> Data for on-chip control registers; sampled on rising edge of SCLK.
16	SDO	O	<b>Serial Data Out.</b> Control and status data from on-chip registers. Updated on falling edge of SCLK; tri-stated during port write or when $\overline{\text{CS}}$ is high.
17	$\overline{\text{CS}}$	I	<b>Chip Select.</b> Must be low to write or read the serial port.
18	SCLK	I	<b>Serial Data Clock.</b> Used to write or read the serial port registers.
19	SPS	I	<b>Serial Port Select.</b> Tie to $V_{\text{DD}}$ to select the serial port. Tie to $V_{\text{SS}}$ to select the hardware mode.

**POWER AND TEST PIN DESCRIPTION (40-PIN DIP ONLY) Table 4**

PIN	SYMBOL	TYPE	DESCRIPTION
20	$V_{\text{SS}}$	-	<b>Signal Ground.</b> 0.0 volts.
32	TEST	I	<b>Test Mode.</b> Tie to $V_{\text{SS}}$ to select the old DS2181 sync algorithm and to tri-state the synchronizer status pins on the DS2181AQ. Tie to $V_{\text{DD}}$ to select the new DS2181A sync algorithm and activate the synchronizer status pins on the DS2181AQ.
40	$V_{\text{DD}}$	-	<b>Positive Supply.</b> 5.0 volts.

**REGISTER SUMMARY Table 5**

REGISTER	ADDRESS	T/R <sup>1</sup>	DESCRIPTION/FUNCTION
RIMR	0000	R	<b>Receive Interrupt Mask Register.</b> Allows masking of alarm generated interrupts.
RSR	0001	R <sup>2</sup>	<b>Receive Status Register.</b> Reports all receive alarm conditions.
BVCR	0010	R	<b>Bipolar Violation Count Register.</b> 8-bit presetable counter which records individual bipolar violations.
CECR	0011	R	<b>CRC4 Error Count Register.</b> 8-bit presetable counter which records individual errors.
FECD	0100	R	<b>Frame Error Count Register.</b> 8-bit presetable counter which logs individual errors in the received frame alignment signal.
RCD	0101	R	<b>Receive Control Register.</b> Establishes receive side operating characteristics.
CCD	0110	T/R	<b>Common Control Register.</b> Establishes additional operating characteristics for transmit and receive sides.
TCR	0111	T	<b>Transmit Control Register.</b> Establishes transmit side operation characteristics.
TIR1 TIR2 TIR3 TIR4	1000 1001 1010 1011	T	<b>Transmit Idle Registers.</b> Designates which outgoing timeslots are to be substituted with idle code.
TINR	1100	T	<b>Transmit International and National Register.</b> When enabled via the TCR, contents inserted into the outgoing national and/or international bit positions.
TXR	1101	T	<b>Transmit Extra Register.</b> When enabled via the TCR, contents inserted into the outgoing extra bit positions.

**NOTES:**

1. Transmit or receive side register.
2. RSR is a read only register; all other registers are read/write.
3. Reserved bit locations must be programmed to 0.

**SERIAL PORT INTERFACE**

Pins 14 through 18 of the DS2181A serve as a microprocessor/ microcontroller-compatible serial port. Fourteen on-chip registers allow the user to update operational characteristics and monitor device status via a host controller, minimizing hardware interfaces.

Port read/write timing is unrelated to the chip transmit and receive timing, allowing asynchronous reads and/ or writes by the host. The timing set is identical to that of 8051-type microcontrollers operating in serial port mode 0. For proper operation of the port and the transmit and receive registers, the user should provide TCLK and RCLK as well as SCLK.

## ADDRESS/COMMAND

An address/command byte write must precede any read or write of the port registers. The first bit written (LSB) of the address/command byte specifies read or write. The following nibble identifies register address. The next 2 bits are reserved and must be set to 0 for proper operation. The last bit of the address/command word enables the burst mode when set; the burst mode allows consecutive reading or writing of all register data. Data is written to and read from the port LSB first.

## CHIP SELECT AND CLOCK CONTROL

All data transfers are initiated by driving the  $\overline{CS}$  input low. Data is sampled on the rising edge of SCLK. Data is output on the falling edge of SCLK and held to the next falling edge. All data transfers are terminated and SDO tri-stated when  $\overline{CS}$  returns to high.

## CLOCKS

To access the serial port registers both TCLK and RCLK are required along with the SCLK. The TCLK and RCLK are used to internally access the transmit and receive registers, respectively. The CCR is considered a receive register for this purpose.

## DATA I/O

Following the eight SCLK cycles that input the address/ command byte, data at SDI is strobed into the addressed register on the next eight SCLK cycles (register write) or data is presented at SDO on the next eight SCLK cycles (register read). SDO is tri-stated during writes and may be tied to SDI in applications where the host processor has bi-directional I/O capability.

## BURST MODE

The burst mode allows all on-chip registers to be consecutively read or written by the host processor. This feature minimizes device initialization time on system power-up or reset. Burst mode is initiated when ACB.7 is set and the address nibble is 0000. *All registers must be read or written during the burst mode. If  $\overline{CS}$  transitions high before the burst is complete, data validity is not guaranteed.*

## ACB: ADDRESS COMMAND BYTE Figure 2

(MSB)				(LSB)			
BM	-	-	ADD3	ADD2	ADD1	ADD0	R/W

SYMBOL	POSITION	NAME AND DESCRIPTION
BM	ACB.7	<b>Burst Mode.</b> If set (and ACB.1 through ACB.4=0) burst read or write is enabled.
-	ACB.6	Reserved, must be 0 for proper operation.
-	ACB.5	Reserved, must be 0 for proper operation.
ADD3	ACB.4	MSB of register address.
ADD2	ACB.3	
ADD1	ACB.2	
ADD0	ACB.1	LSB of register address.
R/W	ACB.0	<b>Read/Write Select.</b> 0 = write addressed register. 1 = read addressed register.

## SERIAL PORT READ/WRITE Figure 3

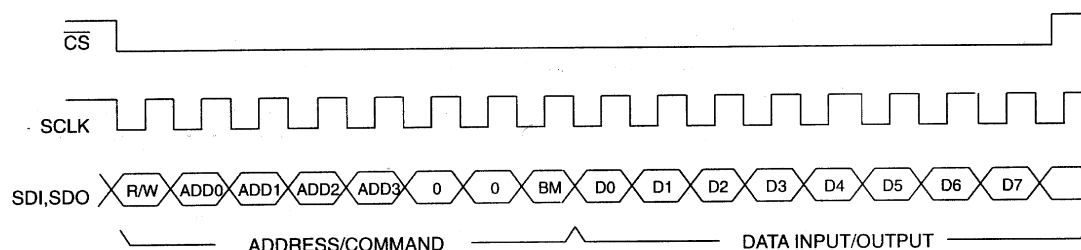

### NOTES:

1. SDI sampled on rising edge of SCLK.
2. SDO updated on falling edge of SCLK.

## TCR: TRANSMIT CONTROL REGISTER Figure 4

(MSB)

(LSB)

TUA1	TSS	TSM	INBS	NBS	XBS	TSA1	ODM
------	-----	-----	------	-----	-----	------	-----

SYMBOL	POSITION	NAME AND DESCRIPTION
TUA1	TCR.7	<b>Transmit Unframed All 1's.</b> 0 = Normal operation. 1 = Replace outgoing data at TPOS and TNEG with unframed all 1's code.
TSS	TCR.6	<b>Transmit Signaling Select<sup>1</sup></b> 0 = Signaling data embedded in the serial bit stream is sampled at TSER during timeslot 16. 1 = Signaling data is channel associated and sampled at TSD as shown in Table 6.
TSM	TCR.5	<b>Transmit Signaling Mode<sup>1</sup></b> 0 = Channel Associated Signaling (CAS). 1 = Common Channel Signaling (CCS).
INBS	TCR.4	<b>International Bit Select</b> 0 = Sample international bit at TIND. 1 = Outgoing international bit = TINR.7.
NBS	TCR.3	<b>National Bit Select</b> 0 = Sample national bits at TIND. 1 = Source outgoing national bits from TINR.4 through TINR.0.
XBS	TCR.2	<b>Extra Bit Select</b> 0 = Sample extra bits at TXD. 1 = Source extra bits from TXR.0 through TXR.1 and TXR.3.
TSA1	TCR.1	<b>Transmit Signaling All 1's</b> 0 = Normal operation. 1 = Force contents of timeslot 16 in all frames to all 1's.
ODM	TCR.0	<b>Output Data Mode</b> 0 = TPOS and TNEG outputs are 100% duty cycle. 1 = TPOS and TNEG outputs are 50% duty cycle.



**NOTE:**

1. When the common channel signaling mode is enabled (TCR.5 = 1), the TSD input is disabled internally; all timeslot 16 data is sampled at TSER.

**CCR: COMMON CONTROL REGISTER Figure 5****(MSB)****(LSB)**

-	TAFP	THDE	RHDE	TCE	RCE	SAS	LLB
---	------	------	------	-----	-----	-----	-----

<b>SYMBOL</b>	<b>POSITION</b>	<b>NAME AND DESCRIPTION</b>
-	CCR.7	Reserved; must be 0 for proper operation.
TAFP	CCR.6	<b>Transmit Align Frame Position<sup>1</sup></b> When clear, the CAS multiframe begins with a frame containing the frame alignment signal. When set, the CAS multiframe begins with a frame not containing the frame alignment signal.
THDE	CCR.5	<b>Transmit HDB3 Enable</b> 0 = Outgoing data at TPOS and TNEG is AMI coded. 1 = Outgoing data at TPOS and TNEG is HDB3 coded.
RHDE	CCR.4	<b>Receive HDB3 Enable</b> 0 = Incoming data at RPOS and RNEG is AMI coded. 1 = Incoming data is RPOS and RNEG is HDB3 coded.
TCE	CCR.3	<b>Transmit CRC4 Enable</b> When set, outgoing international bit positions in frames 0 through 12 and 14 are replaced by CRC4 multiframe alignment and checksum words.
RCE	CCR.2	<b>Receive CRC4 Enable</b> 0 = Disable CRC4 multiframe synchronizer. 1 = Enable CRC4 synchronizer; search for CRC4 multiframe alignment once frame alignment complete.
SAS	CCR.1	<b>Sync Algorithm Select</b> 0 = Use old DS2181 sync algorithm 1 = Use new DS2181A sync algorithm
LLB	CCR.0	<b>Local Loopback</b> 0 = Normal operation. 1 = Internally loop TPOS, TNEG, and TCLK to RPOS, RNEG, and RCLK.

**NOTES:**

1. This bit must be cleared when CRC4 multiframe mode is enabled (CCR.3 = 1); its state does not affect CCS framing (RCR.5 = 1).
2. CCR is considered a receive register and operates from RCLK and SCLK.

**RCR: RECEIVE CONTROL REGISTER** Figure 6**(MSB)****(LSB)**

-	-	RSM	CMSC	CMRC	FRC	SYNCE	RESYNC
---	---	-----	------	------	-----	-------	--------

<b>SYMBOL</b>	<b>POSITION</b>	<b>NAME AND DESCRIPTION</b>
-	RCR.7	Reserved; must be 0 for proper operation.
-	RCR.6	Reserved; must be 0 for proper operation.
RSM	RCR.5	<b>Received Signaling Mode</b> 0 = Channel Associated Signaling (CAS). 1 = Common Channel Signaling (CCS).
CMSC	RCR.4	<b>CAS Multiframe Sync Criteria</b> 0 = Declare sync when fixed sync criteria met. 1 = Declare sync when fixed criteria are met and two additional consecutive valid multiframe alignment signals are detected.
CMRC	RCR.3	<b>CAS Multiframe Resync Criteria</b> 0 = Utilize only fixed resync criteria. 1 = Resync if fixed criteria met and/or if two consecutive timeslot 16 words have values of 0 in the first four MSB positions (0000xxxx).
FRC	RCR.2	<b>Frame Resync Criteria</b> 0 = Utilize only fixed resync criteria. 1 = Resync if fixed criteria met and/or if bit 2 in timeslot 0 of non-align frames is received in error on three consecutive occasions.
SYNCE	RCR.1	<b>Sync Enable</b> If clear, the synchronizer will automatically begin resync if error criteria are met. If high, no auto resync occurs.
RESYNC	RCR.0	<b>Resync</b> When toggled low to high, the receive synchronizer will initiate immediately. The bit must be cleared, then set again for subsequent resyncs.

**CEPT FRAME STRUCTURE**

The CEPT frame is made up of 32 8-bit channels (time-slots) numbered from 0 to 31. The frame alignment signal in bit positions 2 through 8 of timeslot 0 of every other frame is independent of the various multiframe modes described below. Outputs TAF and RAF indicate frames which contain the alignment signal. Timeslot 0 of frames not containing the frame alignment signal is used for alarm and national data. See the separate DS2181A CEPT Transceiver Application Note for more details.

**CAS SIGNALLING**

CEPT networks support Channel Associated Signaling (CAS) or Common Channel Signaling (CCS). These signaling modes are independently selectable for transmit and receive sides.

CAS (selected when TCR.5 = 0 and/or when RCR.5 = 0) is a bit-oriented signaling technique which utilizes a 16-frame multiframe. The multiframe alignment signal (0-hex), extra and alarm bits occupy timeslot 16 of frame 0. Timeslot 16 of the remaining 15 frames is reserved for channel signaling data. Four signaling bits (A, B, C and D) are transmitted once per multiframe as shown in Figure 7. Input TMSYNC establishes the transmitted CAS multiframe position. Signaling data can be sourced from input TSD (TCR.6 = 1) or multiplexed into TSER (TCR.6 = 0).

## CCS SIGNALLING

CCS (selected when  $TCR.5 = 1$  and/or when  $RCR.1 = 1$ ) utilizes all bit positions of timeslot 16 in every frame for message-oriented signaling data transmission. In CCS mode one can use either timeslot 16 or any one of the other 30 data channels for message-oriented signaling. The CCS mode has no multiframe structure and the insertion of CAS multiframe alignment, distant multiframe alarm and/or extra bits into timeslot 16 is disabled. TSER is the source of timeslot 16 data.

## CRC4 CODING

The need for enhanced error monitoring capability and additional protection against emulators of the frame alignment word has led to the development of a cyclic redundancy check (CRC) procedure. When enabled via  $CCR.2$  and/or  $CCR.3$ , CRC4 coding replaces the international bit positions in frames 0 through 12 and 14 with a CRC4 multiframe alignment pattern and associated checksum words. The CRC4 multiframe must begin with a frame containing the frame alignment signal ( $CCR.6 = 0$ ). A rising edge at TMSYNC establishes the CRC4 multiframe alignment (TMSYNC will also establish outgoing CAS multiframe alignment if enabled via  $TCR.5$ ).

Incoming CRC4 multiframe alignment is indicated by RCSYNC. Detected CRC4 checksum errors are reported at output RFER and logged in the CECR.

## RECEIVE SYNCHRONIZER

The fixed characteristics of the receive synchronizer may be modified by use of programmable characteristics resident in the RCR and CCR. Sync criteria must be met before synchronization is declared. Resync criteria establish error occurrences which will cause an auto-resync event when enabled ( $RCR.1 = 0$ ).

The receive synchronizer searches for the frame alignment pattern first. Once identified, the output timing set associated with the framing pattern (all outputs except RCSYNC and RMSYNC) is updated to that new alignment. If enabled, the synchronizer then begins CAS and/or CRC4 multiframe search; outputs RMSYNC and/or RCSYNC are then updated. Output RLOS is held high during the entire resync process, then transitions low after the last output timing update indicating resync is complete. For more details about the receive synchronizer, see the separate DS2181A CEPT Transceiver Application Note.

## FIXED FRAME SYNC CRITERIA

Valid frame sync is assumed when the correct frame alignment signal is present in frame  $N$  and frame  $N + 2$  and not present in frame  $N + 1$  (bit 2 of timeslot 0 of Frame  $N + 1$  is also checked for 1). CAS and/or CRC4 multiframe alignment search is initiated when the frame search is complete if enabled via  $RCR.5$  and/or  $CCR.2$ .

## FIXED CAS MULTIFRAME SYNC CRITERIA

CAS multiframe sync is declared when the multiframe alignment pattern is properly detected and timeslot 16 of the previous frame contains code other than zeros. If no valid pattern can be found in 12 to 14 milliseconds (no time-out period exists if  $CCR.1=1$  or  $TEST=1$ ), frame search is restarted.

## FIXED CRC4 MULTIFRAME SYNC CRITERIA

CRC4 multiframe sync is declared if at least two valid CRC4 multiframe alignment signals are found within 12 to 14 milliseconds (8 ms if  $CCR.1=1$  or  $TEST=1$ ) after frame alignment is completed. If not found within 12 to 14 milliseconds (8 ms if  $CCR.1=1$  or  $TEST=1$ ), frame search is restarted. The search for the multiframe alignment signal is performed in timeslot 0 of frames not containing the frame alignment signal.

## FIXED FRAME RESYNC CRITERIA

When enabled via RCR.1, the device will automatically initiate frame search whenever the frame alignment word is received in error three consecutive times.

## FIXED CAS MULTIFRAME RESYNC CRITERIA

When enabled via RCR.1, the device will automatically initiate frame search whenever two consecutive CAS multiframe alignment words are received in error.

## FIXED CRC4 RESYNC CRITERIA

If CCR.1=1 or if the TEST pin is tied high, then the DS2181A will initiate the resync at the FAS level if 915 or more CRC4 words out of 1000 are received in error.

## CAS SIGNALLING SOURCE

CAS applications sample signaling data at TSER when TCR.6 = 0; an on-chip data multiplexer accepts channel-associated data input at TSD when TCR.6 = 1. The data multiplexer must be disabled (TCR.6 = 0) when the CCS mode is enabled (TCR.5 = 1).

## TSD INPUT TIMING (TCR.6 = 1; TCR.5 = 0) Table 6

FRAME #	TIMESLOT SIGNALING DATA SAMPLED AT TSD
0	17
1	1, 18
2	2, 19
3	3, 20
4	4, 21
5	5, 22
6	6, 23
7	7, 24
8	8, 25
9	9, 26
10	0, 27
11	11, 28
12	12, 29
13	13, 30
14	14, 31
15	15

## NOTE:

1. A, B, C and D data is sampled on falling edges of TCLK during bit times 5, 6, 7 and 8 of timeslots indicated.

## TSD INPUT TIMING Figure 7

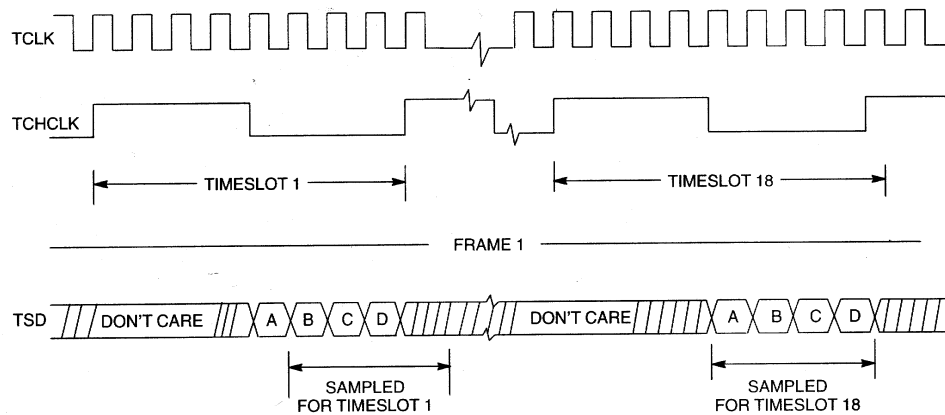

## CAS OUTPUT FORMAT IN TIMESLOT 16 Figure 8

FRAME 0 <sup>1</sup>	FRAME 1			FRAME 15	
0000XYXX	ABCD for Timeslot 1	ABCD for timeslot 17	---	ABCD for Timeslot 15	ABCD for Timeslot 31

### NOTE:

1. Timeslot 16 of frame 0 is reserved for the multiframe alignment word (0000), distant multiframe alarm (Y) and extra bits (X-XX).

## TINR: TRANSMIT INTERNATIONAL AND NATIONAL REGISTER Figure 9

(MSB)			(LSB)				
INB	-	TRA	NB4	NB5	NB6	NB7	NB8

SYMBOL	POSITION	NAME AND DESCRIPTION
INB	TINR.7	<b>International Bit.</b> Inserted into the outgoing data stream when TCR.4 = 1.
-	TINR.6	Reserved; must be 0 for proper operation.
TRA	TINR.5	<b>Transmit Remote Alarm</b> 0 = Normal operation; bit 3 of timeslot 0 in non-alignment frame clear. 1 = Alarm condition; bit 3 of timeslot 0 in non-align frames set.
NB4	TINR.4	<b>Transmit National Bits.</b> Inserted into the outgoing data stream at TPOS and TNEG when TCR.3 = 1.
NB5	TINR.3	
NB6	TINR.2	
NB7	TINR.1	
NB8	TINR.0	

## TRANSMIT INTERNATIONAL AND NATIONAL DATA

Bit 1 of timeslot 0 in all frames is known as the international bit. When TCR.4 = 1, the transmitted international bit is sourced from TINR.7. When TCR.4 = 0, the transmitted international bit is sampled at TIND during the first bit period of each frame. The international bit positions in all outgoing frames except 13 and 15 are replaced by CRC4 code words and the CRC4 multiframe alignment signal when CCR.3 = 1.

Bits 4 through 8 of timeslot 0 in non-align frames are reserved for national use. When TCR.3 = 1, the transmitted national bits are sourced from register locations TINR.4 through TINR.0. If TCR.3 = 0, the national bits are sampled at TIND during bit times 4 through 8 of timeslot 0 in non-align frames.

Reserved bit positions in the TINR must be set to 0 when written; those bits can be 0 or 1 when read.

## TXR: TRANSMIT EXTRA REGISTER Figure 10

(MSB)				(LSB)			
-	-	-	-	XB1	TDMA	XB2	XB3

SYMBOL	POSITION	NAME AND DESCRIPTION
-	TXR.7	Reserved; must be 0 for proper operation.
-	TXR.6	Reserved; must be 0 for proper operation.
-	TXR.5	Reserved; must be 0 for proper operation.
-	TXR.4	Reserved; must be 0 for proper operation.
XB1	TXR.3	<b>Extra Bit 1</b>
TDMA	TXR.2	<b>Transmit Distant Multiframe Alarm</b> 0 = Normal operation; bit 6 of timeslot 16 in frame 0 clear. 1 = Alarm condition; bit 6 of timeslot 16 in frame 0 set.
XB2	TXR.1	<b>Extra Bit 2</b>
XB3	TXR.0	<b>Extra Bit 3</b>

## TRANSMIT EXTRA DATA

In the CAS mode, timeslot 16 of frame 0 contains the multiframe alignment pattern, extra bits and the distant multiframe alarm. When CAS is enabled (TCR.5 = 0), the extra bits are sourced from TXR.0, TXR.1 and TXR.3 (TCR.2 = 1) or the extra bits are sampled externally at TXD during the extra bit time (TCR.2 = 0). The extra bits, alignment pattern and alarm signal are not utilized in the CCS mode (TCR.5 = 1); input TSER overwrites all timeslot 16 bit positions.

Reserved bit positions in the TXR must be set to 0 when written; those bits can be 0 or 1 when read.

## TIR1 - TIR4: TRANSMIT IDLE REGISTERS Figure 11

(MSB)				(LSB)				
TS7	TS6	TS5	TS4	TS3	TS2	TS1	TS0 <sup>1</sup>	TIR1
TS15	TS14	TS13	TS12	TS11	TS10	TS9	TS8	TIR2
TS23	TS22	TS21	TS20	TS19	TS18	TS17	TS16 <sup>1</sup>	TIR3
TS31	TS30	TS29	TS28	TS27	TS26	TS25	TS024	TIR4

SYMBOL	POSITION	NAME AND DESCRIPTION
TS31	TIR4.7	<b>Transmit Idle Registers</b>
TS0	TIR1.0	Each of these bit positions represents a timeslot in the outgoing stream at TPOS and TNEG; when set, the contents of that timeslot are forced to idle code (11010101).

### NOTE:

1. TS0 and TS16 are not affected by the idle register.

## TRANSMIT TIMING

A low-high transition at TMSYNC once per multiframe (every 2 milliseconds) or at a multiple of the multiframe rate establishes outgoing CAS and/or CRC4 multiframe alignment. Output TMO indicates that alignment. A low-high transition at TFSYNC at the frame rate (125 us) or at a multiple of the frame rate establishes the outgoing frame position. Output TAF indicates that alignment. TMSYNC and/or TFSYNC can be tied low by the user, in which case the arbitrary frame and multiframe alignment established by the device will be indicated at TMO and TAF.

Output TAF also indicates frames containing the frame alignment signal. Those frames can be even or odd numbering frames of the outgoing CAS multiframe (CCR.6).

## TRANSMIT MULTIFRAME TIMING Figure 12

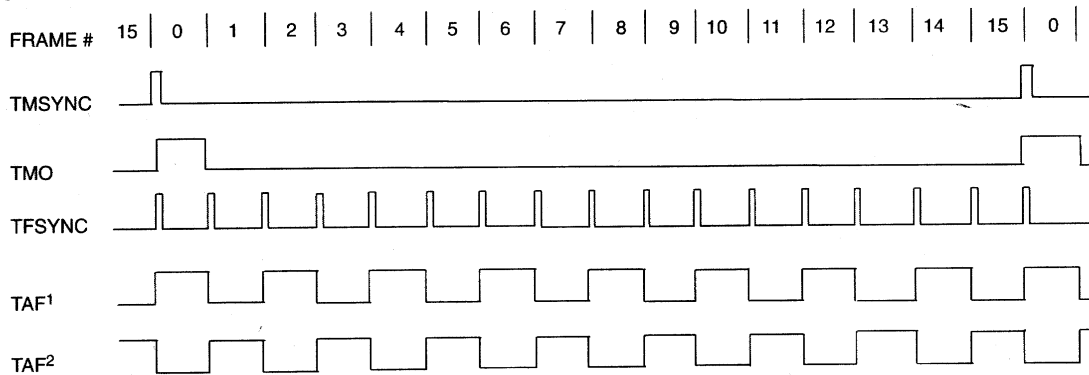

## NOTES:

1. Alignment frames are even frames of the CAS and/or CRC4 multiframes (CCR.6 = 0).
2. Alignment frames are odd frames of the CAS multiframe (CCR.6 = 1).

## TRANSMIT MULTIFRAME BOUNDARY TIMING Figure 13

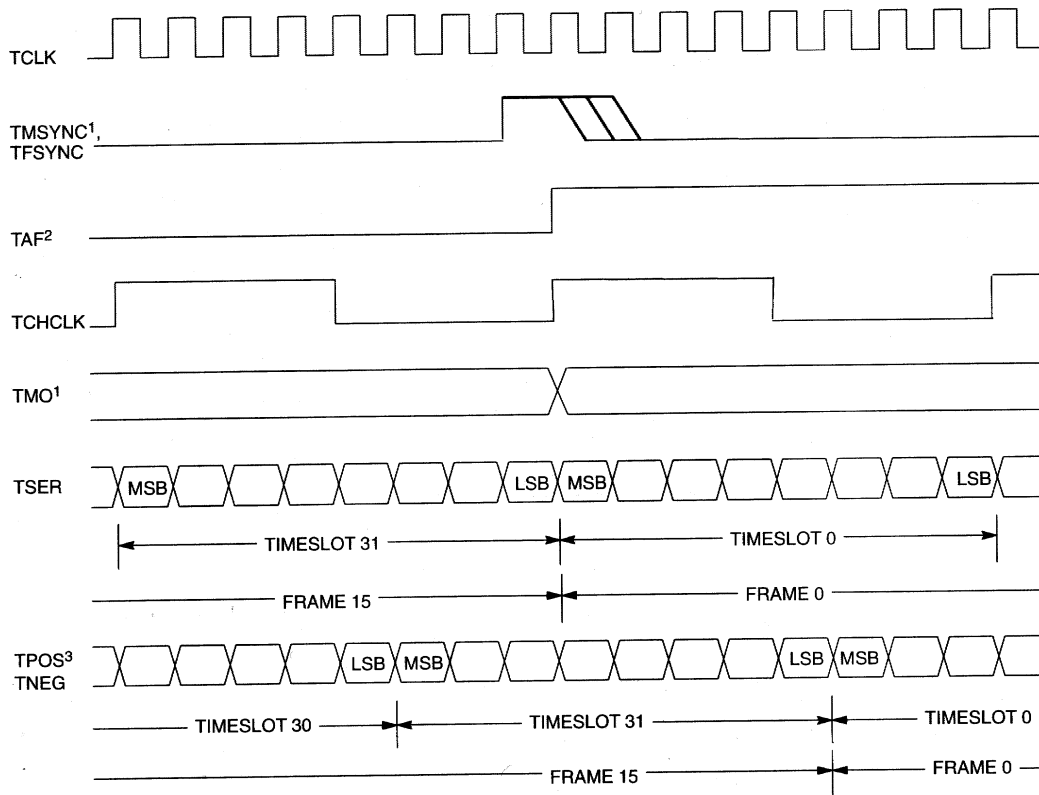

### NOTES:

1. Low-high transitions on TMSYNC and/or TFSYNC must occur one TCLK period early with respect to actual frame and multiframe boundaries. TMO follows the rising edge of TMSYNC or TFSYNC.
2. TAF transitions on true frame boundaries.
3. Delay from TSER to TPOS, TNEG is five TCLK periods.

## TRANSMIT SIGNALING TIMESLOT TIMING Figure 14

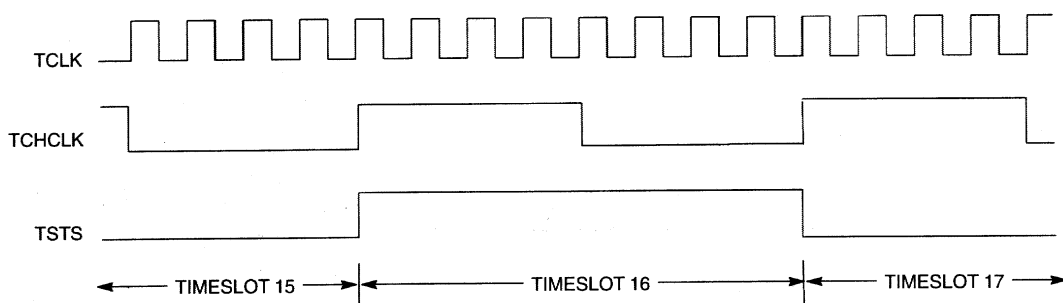

## RECEIVE SIGNALING

Receive signaling data is available at two outputs: RSER and RSD. RSER outputs the signaling data in timeslot 16 at RSER. The signaling data is also extracted from timeslot 16 and presented at RSD during the timeslots shown in Table 7. This channel-associated signaling simplifies CAS system design.



**RECEIVE SIGNALING Table 7**

FRAME #	RSD <sup>1</sup> VALID DURING TIMESLOT #
0	15, <sup>-2</sup>
1	<sup>-2</sup> , 17
2	1, 18
3	2, 19
4	3, 20
5	4, 21
6	5, 22
7	6, 23
8	7, 24
9	8, 25
10	9, 26
11	10, 27
12	11, 28
13	12, 29
14	13, 30
15	14, 31

**NOTES:** (Applicable only to CAS systems)

1. RSD is valid for the least significant nibble in each indicated timeslot. Timeslot A data appears in bit 5, B in bit 6, C in bit 7 and D in bit 8.
2. RSD does not output valid data during timeslots 0 and 16.

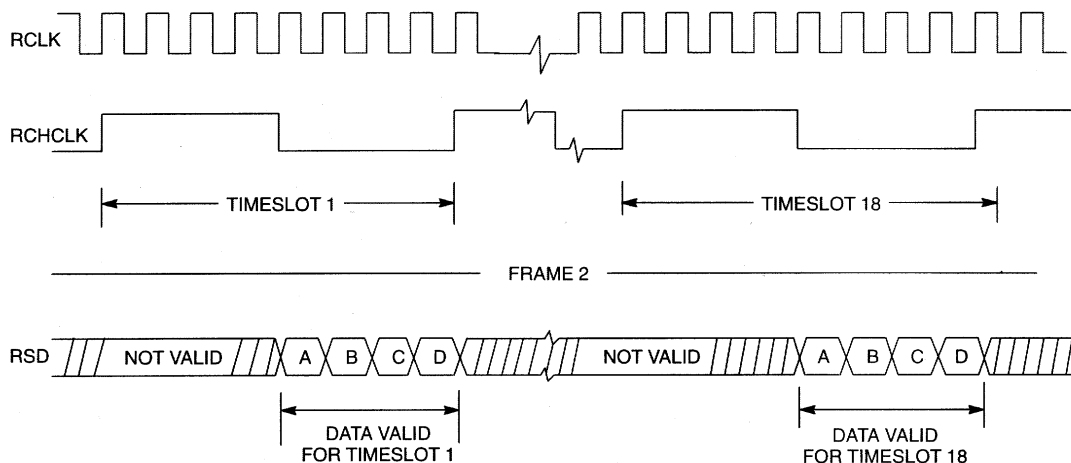
**RECEIVE MULTIFRAME TIMING Figure 15****RECEIVE TIMING**

The receive side output timing set is identical to that found on the transmit side. The user can tie receive outputs directly to the transmit inputs for drop and insert applications. The received data of RPOS, RNEG appear at RSER after six RCLK delays, without any change except for the HDB3-to-NRZ conversion when HDB3 is enabled.

**NOTE:**

1. The CAS multiframe can start with an align or non-align frame. The CRC4 multiframe always starts with an align frame.

**RSD TIMING Figure 16**

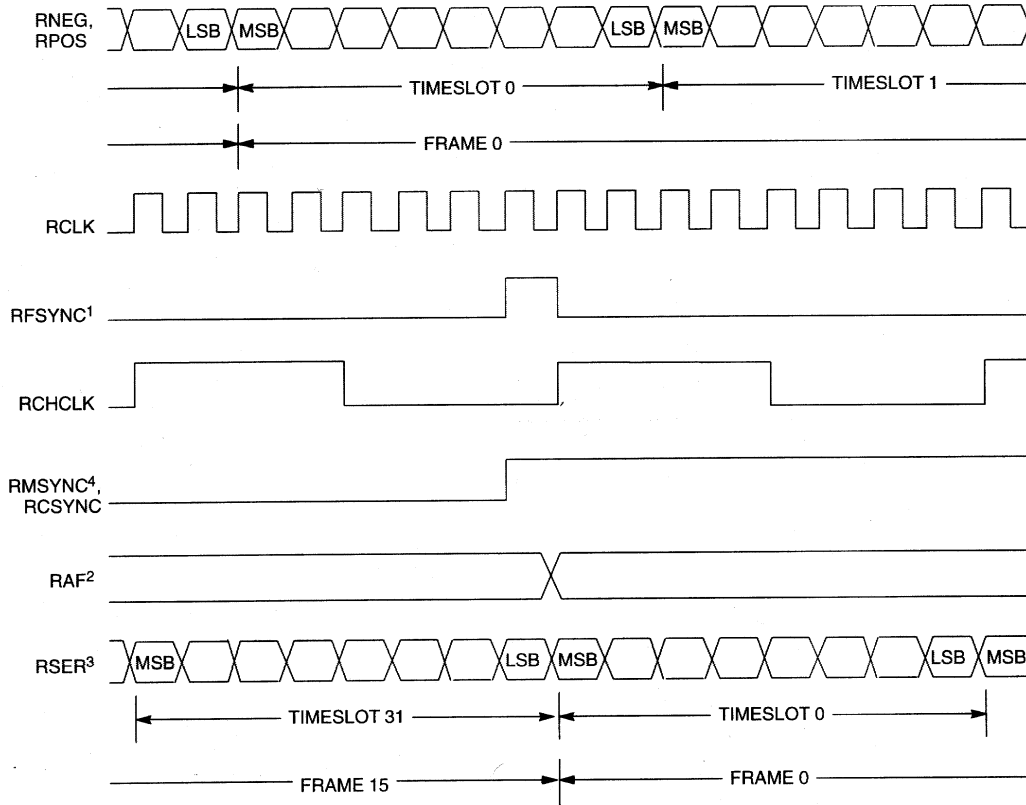

## RECEIVE MULTIFRAME BOUNDARY TIMING Figure 17

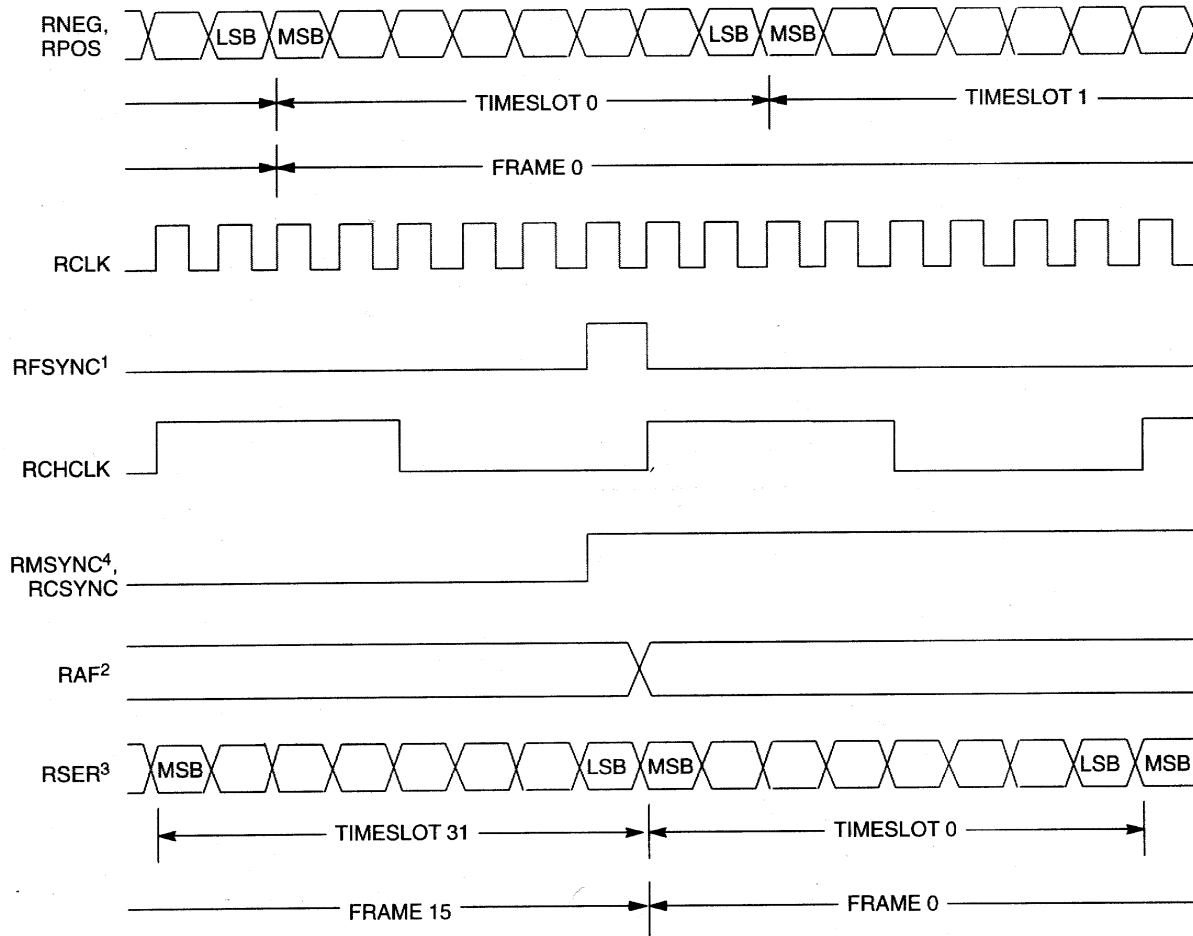

### NOTES:

1. Low-high transitions on RMSYNC and RFSYNC occur one RCLK period early with respect to actual frame and multiframe boundaries.
2. RAF transitions on true frame boundaries.
3. Delay from RPOS, RNEG to RSEr is six RCLK periods.
4. RMSYNC and RASync transition low on the falling edge of RFSYNC.

**RSR: RECEIVE STATUS REGISTER** Figure 18**(MSB)****(LSB)**

RRA	RDMA	RSA1	RUA1	FSERR	MFSERR	RLOS	ECS
-----	------	------	------	-------	--------	------	-----

<b>SYMBOL</b>	<b>POSITION</b>	<b>NAME AND DESCRIPTION</b>
RRA	RSR.7	<b>Receive Remote Alarm.</b> Set when bit 3 of timeslot 0 in non-align frames set for three consecutive non-align frames.
RDMA	RSR.6	<b>Receive Distant Multiframe Alarm.</b> Set when bit 6 of timeslot 16 in frame 0 is set for three consecutive multiframe.
RSA1	RSR.5	<b>Receive Signaling All Ones.</b> Set when the contents of timeslot 16 have been all 1's for two consecutive frames.
RUA1	RSR.4	<b>Receive Unframed All Ones.</b> Set when less than three 0s have been received in the last two consecutive frames.
FSERR	RSR.3	<b>Frame Resync Criteria Met.</b> Set when the frame error criteria are met; also the frame resync is initiated if RCR.1=0.
MFSERR	RSR.2	<b>CAS Multiframe Resync Criteria Met.</b> Set when the CAS multiframe error criteria are met; also, the frame resync is initiated if RCR.1=0.
RLOS	RSR.1	<b>Receive Loss of Sync.</b> Set when resync is in progress.
ECS	RSR.0	<b>Error Counter Saturation.</b> Set when any of the on-chip counters at FECR, CECR or BVCR saturates.

**NOTE:**

1. When in the CCS mode, the RDMA flag bit and the RDMA pin have no significance. It will be set when bit 6 of timeslot 16 in frame 0 is set for three consecutive multiframe in either CAS or CCS mode.

**RIMR: RECEIVE INTERRUPT MASK REGISTER** Figure 19**(MSB)****(LSB)**

RRA	RDMA	RSA1	RUA1	FSERR	MFSERR	RLOS	ECS
-----	------	------	------	-------	--------	------	-----

<b>SYMBOL</b>	<b>POSITION</b>	<b>NAME AND DESCRIPTION</b>
RRA	RIMR.7	<b>Receive Remote Alarm</b> 1 = Interrupt enabled 0 = Interrupt masked
RDMA	RIMR.6	<b>Receive Distant Multiframe Alarm</b> 1 = Interrupt enabled 0 = Interrupt masked
RSA1	RIMR.5	<b>Receive Signaling All 1's</b> 1 = Interrupt enabled 0 = Interrupt masked
RUA1	RIMR.4	<b>Receive Unframed All 1's</b> 1 = Interrupt enabled 0 = Interrupt masked
FSERR	RIMR.3	<b>Frame Resync Criteria Met</b> 1 = Interrupt enabled 0 = Interrupt masked
MFSERR	RIMR.2	<b>CAS Multiframe Resync Criteria Met</b> 1 = Interrupt enabled 0 = Interrupt masked
RLOS	RIMR.1	<b>Receive Loss of Sync</b> 1 = Interrupt enabled 0 = Interrupt masked
ECS	RIMR.0	<b>Error Count Saturation</b> 1 = Interrupt enabled 0 = Interrupt masked

**ALARM REPORTING AND INTERRUPT SERVICING**

Alarm and error conditions are reported at outputs and the RSR. Use of the RSR and error count registers simplifies system error monitoring. The RSR can be read in one of two ways: a burst read does not disturb the RSR contents; a direct read will clear all bits set in the RSR unless the alarm condition which set them is still active. Interrupts are enabled via the RIMR and are generated whenever an alarm or error condition sets an RSR bit. The host controller must service the transceiver in order to clear an interrupt condition. Clearing the appropriate RIMR bit will unconditionally clear an interrupt.

**BVCR: BIPOLAR VIOLATION COUNT REGISTER** Figure 20**(MSB)****(LSB)**

BVD7	BVD6	BVD5	BVD4	BVD3	BVD2	BVD1	BVD0
------	------	------	------	------	------	------	------

<b>SYMBOL</b>	<b>POSITION</b>	<b>NAME AND DESCRIPTION</b>
BVD7	BVCR.7	MSB of bipolar violation count.
BVD0	BVCR.0	LSB of bipolar violation count.

**CECR: CRC4 ERROR COUNT REGISTER** Figure 21**(MSB)****(LSB)**

CRC7	CRC6	CRC5	CRC4	CRC3	CRC2	CRC1	CRC0
------	------	------	------	------	------	------	------

**SYMBOL      POSITION      NAME AND DESCRIPTION**

CRC7	BVCR.7	MSB of CRC4 error count.
CRC0	BVCR.0	LSB of CRC4 error count.

**FECR: FRAME ERROR COUNT REGISTER** Figure 22**(MSB)****(LSB)**

FE7	FE6	FE5	FE4	FE3	FE2	FE1	FE0
-----	-----	-----	-----	-----	-----	-----	-----

**SYMBOL      POSITION      NAME AND DESCRIPTION**

FE7	FECR.7	MSB of frame error count.
FE0	FECR.0	LSB of frame error count.

**ERROR LOGGING**

The BVCR, CECR and FECR contain 8-bit binary up counters which increment on individual bipolar violations, CRC4 code word errors (when CCR.2 = 1), and word errors in the frame alignment signal. Each counter saturates at 255. Once saturated, each following error occurrence will generate an interrupt (RIMR.0 = 1) until the register is reprogrammed to a value other than FF (hex). Presetting the registers allows the user to establish specific error count thresholds; the counter will count up to saturation from the preset value. The BVCR increments at all times (regardless of sync status), except when HDB3 code words are received with CCR.4=1. CECR and FECR increments are disabled whenever resync is in progress (RLOS high).

**ALARM OUTPUTS**

Alarm conditions are also reported real time at alarm outputs. These outputs can be used with off-chip logic to complement the on-chip error reporting capability of the DS2181A. In the hardware mode, they are the only alarm reporting means available.

**RLOS**

The RLOS output indicates the status of the receive synchronizer. When high, frame, CAS multiframe and/or CRC4 multiframe synchronization is in progress. A high-low transition indicates resync is complete. The RLOS bit (RSR.1) is a latched version of the RLOS output.

**RRA**

The remote alarm output transitions high when a remote alarm is detected. A high-low transition indicates the alarm condition has been cleared. The alarm condition is defined as bit 3 of time slot 0 set for three consecutive non-align frames. The alarm state is cleared when bit 3 has been clear for three consecutive non-align frames. The RRA bit (RSR.7) is a latched version of the RRA Output.

**RBV**

RBV pulses high when the accused bit emerges at RSER. RBV will return low when RCLK goes low. Bipolar violations are also logged in the BVCR. The RBV pin provides a pulse for every violation which can be counted externally.

## RDMA

RDMA transitions high when bit 6 of timeslot 16 in frame 0 is set for three consecutive occasions and returns low when the bit is clear for three consecutive occasions. The RDMA bit (RSR.6) is a latched version of the RDMA output.

## RCL

RCL transitions high after 32 consecutive 0s appear at RPOS and RNEG; it goes low at the next 1 occurrence.

## RFER

The RFER output transitions high when received frame alignment, CAS multiframe alignment and/or CRC4 code words are in error. The FECR and CECR log error events reported at this output. FECR logs only the frame alignment word errors. CECR logs CRC4 code word errors.

To complement the on-chip error logging capabilities of the DS2181A, the system designer can use off-chip logic gated by receive side outputs RCHCLK, RAF, RSTS and RCSYNC to demux error states present at RFER. See the separate DS2181A CEPT Transceiver Application Note for more details.

### RFER OUTPUT TIMING FOR ALL ERROR CONDITIONS Figure 23

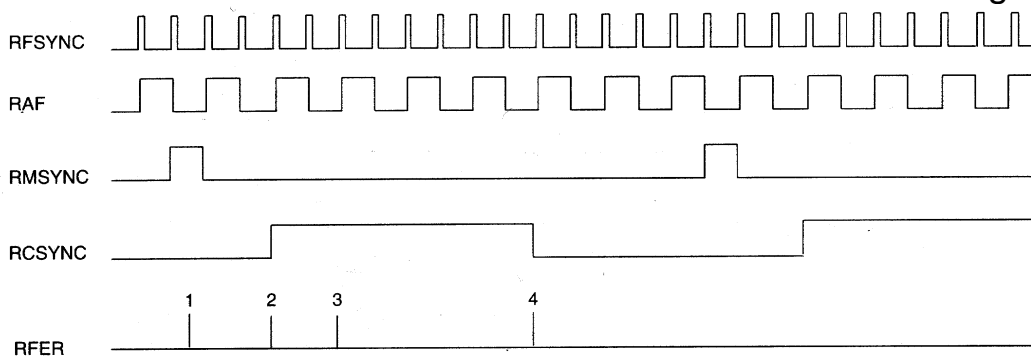

### CAS MULTIFRAME ALIGNMENT ERROR Figure 24

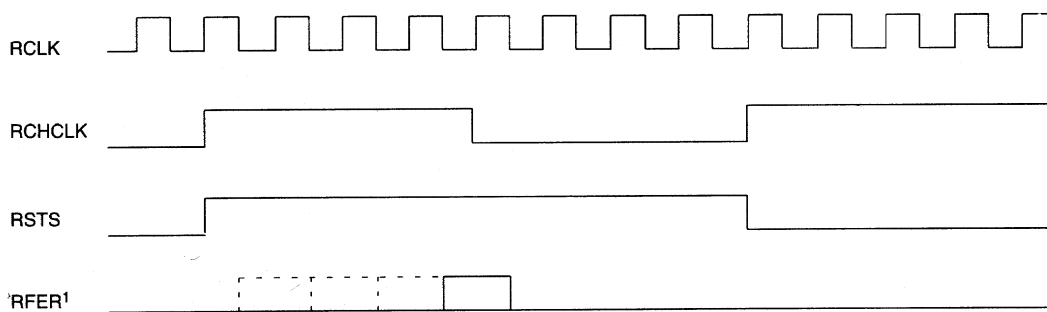

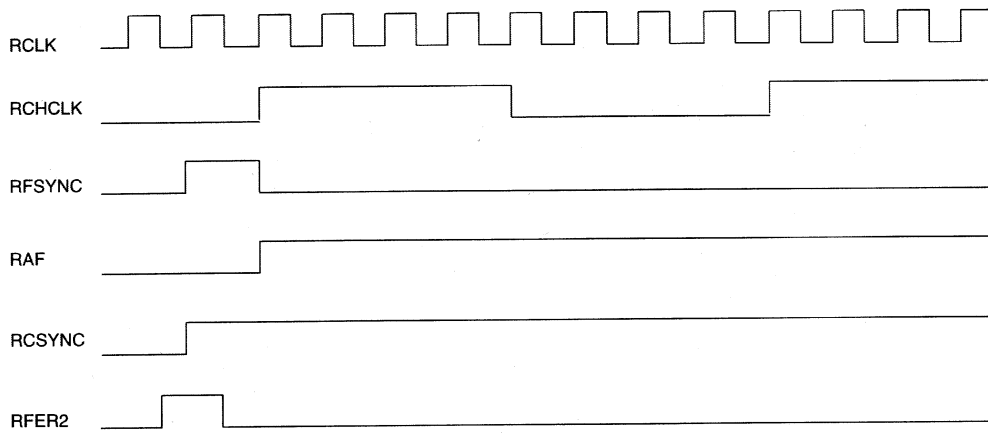
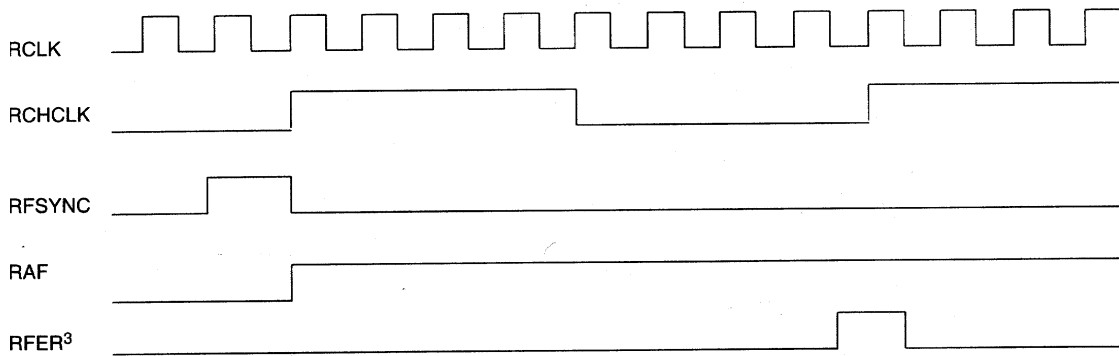
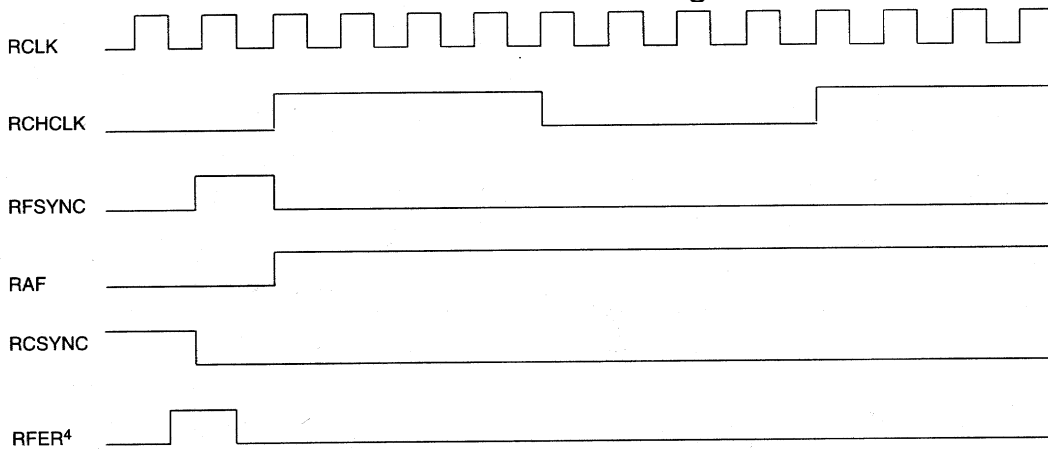
**CRC4 SUB-MULTIFRAME 2 ERRORED Figure 25****FRAME ALIGNMENT WORD ERRORED Figure 26****CRC4 SUB-MULTIFRAME 1 ERRORED Figure 27****NOTES FOR FIGURES 23 THROUGH 27:**

1. CAS multiframe alignment word received in error; RFER will transition high at first error occurrence and remain high as shown.
2. Previous CRC4 sub-multiframe 2 errored.
3. Frame alignment word errored.
4. Previous CRC4 sub-multiframe 1 errored.



## RESET

A high-low transition on  $\overline{\text{RST}}$  clears all internal registers except the three error counters; a resync is initiated until  $\overline{\text{RST}}$  returns high.  $\overline{\text{RST}}$  must be held low on system power-up and when switching to/from the hardware mode. Following reset, the host processor should update all on-chip registers to establish desired operating modes.

## HARDWARE MODE

An on-chip hardware control mode simplifies preliminary system prototyping and serves applications which do not require the features of the serial port. Tying SPS low disables the serial port, clears all internal register locations except those shown below, and redefines pins 14 through 18 as mode control inputs. The mode control inputs establish device operational characteristics as shown in Table 8. The hardware mode simplifies device retrofit into existing applications where control interfaces are designed with discrete logic.

**HARDWARE MODE CONTROL Table 8**

PIN NUMBER	REGISTER LOCATION	NAME AND DESCRIPTION
14 (16)	TINR.5	<b>TRA - Transmit Remote Alarm</b> 0 = Normal operation 1 = Enable alarm
15 (17)	TXR.2	<b>TDMA - Transmit Distant Multiframe Alarm</b> 0 = Normal operation 1 = Enable alarm
16 (18)	CCR.5/CCR.4	<b>Data Format</b> 0 = Input and output data AMI coded 1 = Input and output data HDB3 coded
17 (19)	CCR.3/CCR.2	<b>Transmit and Receive CRC4 Multiframe</b> 0 = Disabled 1 = Enabled
18 (20)	TCR.5/RCR.5	<b>Transmit and Receive CAS Multiframe</b> 0 = Enabled 1 = Disabled

### NOTE:

1. Pin numbers for PLCC package are listed in parenthesis.

**ABSOLUTE MAXIMUM RATINGS\***

Voltage on Any Pin Relative to Ground	-1.0V to +7.0V
Operating Temperature	0° to 70°C
Storage Temperature	-55°C to +125°C
Soldering Temperature	260°C for 10 seconds

\* This is a stress rating only and functional operation of the device at these or any other conditions above those indicated in the operation sections of this specification is not implied. Exposure to absolute maximum rating conditions for extended periods of time may affect reliability.

**RECOMMENDED DC OPERATING CONDITIONS** (0°C to 70°C)

PARAMETER	SYMBOL	MIN	TYP	MAX	UNITS	NOTES
Input Logic 1	$V_{IH}$	2.0		$V_{DD}+.3$	V	
Input Logic 0	$V_{IL}$	-0.3		+0.8	V	
Supply	$V_{DD}$	4.5		5.5	V	

**DC ELECTRICAL CHARACTERISTICS** (0°C to 70°C;  $V_{DD} = 5.0V \pm 10\%$ )

PARAMETER	SYMBOL	MIN	TYP	MAX	UNITS	NOTES
Supply Current	$I_{DD}$		6	10	mA	1,2
Input Leakage	$I_{IL}$	-1.0		+1.0	$\mu A$	3
Output Current @ 2.4V	$I_{OH}$	-1.0			mA	4
Output Current @ .4V	$I_{OL}$	+4.0			mA	5
Output Leakage	$I_{LO}$	-1.0		+1.0	$\mu A$	6

**NOTES:**

1.  $TCLK = RCLK = 2.048$  MHz.
2. Outputs open.
3.  $0V < V_{IN} < V_{DD}$ .
4. All outputs except  $\overline{INT}$ , which is open collector.
5. All outputs.
6. Applies to SDO when tri-stated.

## SERIAL PORT WRITE AC TIMING DIAGRAM Figure 28

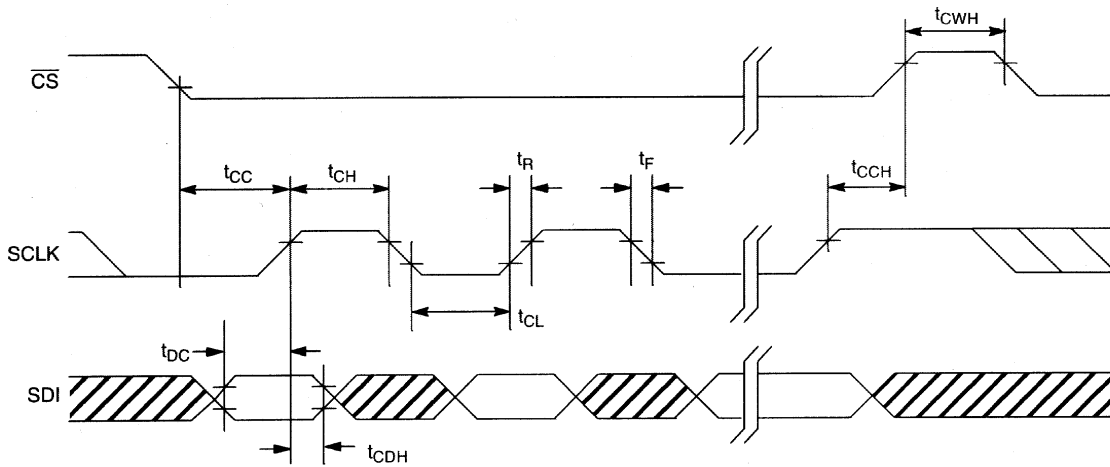

### NOTE:

1. Shaded regions indicate "don't care" states of input data.

## SERIAL PORT READ<sup>1</sup> AC TIMING Figure 29

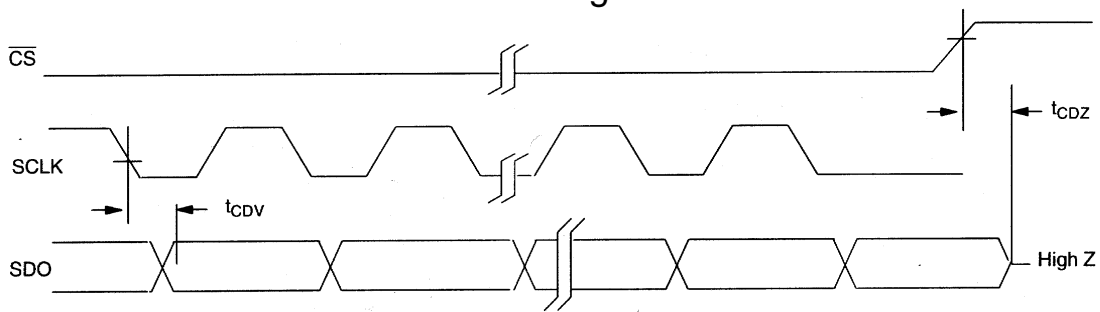

### NOTE:

1. Serial port write must precede a port read to provide address information.

**AC ELECTRICAL CHARACTERISTICS<sup>1,2</sup> SERIAL PORT**(0°C to 70°C;  $V_{DD} = 5.0V \pm 5\%$ )

PARAMETER	SYMBOL	MIN	TYP	MAX	UNITS	NOTES
SDI to SCLK Setup	$t_{DC}$	50			ns	
SCLK to SDI Hold	$t_{CDH}$	50			ns	
SCLK Low Time	$t_{CL}$	244			ns	
SCLK High Time	$t_{CH}$	244			ns	
SCLK Rise and Fall Time	$t_R, t_F$			100	ns	
$\overline{CS}$ to SCLK Setup	$t_{CC}$	50			ns	
SCLK to $\overline{CS}$ Hold	$t_{CCH}$	50			ns	
$\overline{CS}$ Inactive Time	$t_{CWH}$	2.5			ns	
SLK to SDO Valid	$t_{CDV}$			200	ns	
$\overline{CS}$ to SDO High Z	$t_{CDZ}$			75	ns	

**NOTES:**

1. Measured at  $V_{IH}=2.0V$ ;  $V_{IL}=.8V$  and 10 ns maximum rise and fall time.
2. Output load capacitance = 100 pF.

**AC ELECTRICAL CHARACTERISTICS<sup>1,2</sup> – TRANSMIT**(0°C to 70°C;  $V_{DD} = 5.0V \pm 5\%$ )

PARAMETER	SYMBOL	MIN	TYP	MAX	UNITS	NOTES
TCLK Period	$t_p$		488		ns	
TCLK Pulse Width	$t_{WL}, t_{WH}$		244		ns	
TCLK Raise & Fall Time	$t_w, t_R$		20		ns	
TSER, TSD, TIND and TXD Setup to TCLK Falling	$t_{STD}$	50			ns	
TSER, TSD, TIND and TXD Hold to TCLK Falling	$t_{HTD}$	50			ns	
TFSYNC, TMSYNC Setup to TCLK Falling	$t_{STS}$	75			ns	
TFSYNC, TMSYNC Hold to TCLK Falling	$t_{HTS}$	50			ns	
Propagation Delay TCLK to TCHCLK, TSTS, TMO, TAF	$t_{PTS}$			75	ns	

**NOTES:**

1. Measured at  $V_{IH} = 2.0V$ ;  $V_{IL} = .8V$  and 10 ns maximum rise and fall time.
2. Output load capacitance = 100 pF.

**AC ELECTRICAL CHARACTERISTICS<sup>1,2</sup> – RECEIVE**(0°C to 70°C;  $V_{DD} = 5.0V \pm 5\%$ )

PARAMETER	SYMBOL	MIN	TYP	MAX	UNITS	NOTES
Propagation Delay RCLK to RMSYNC, RFSYNC, RSTS, RCHCLK, RAF	$t_{PRS}$			75	ns	
Propagation Delay RCLK to RSER, RSD	$t_{PRD}$			75	ns	
Transition Time All Outputs	$t_{TTR}$			20	ns	
RCLK Period	$t_P$		488		ns	
RCLK Pulse Width	$t_{WL}, t_{WH}$		244		ns	
RCLK Rise and Fall Times	$t_R, t_F$		20		ns	
RPOS, RNEG Setup to RCLK Falling	$t_{SRD}$	50			ns	
RPOS, RNEG Hold to RCLK Falling	$t_{HRD}$	50			ns	
Propagation Delay RCLK to RLOS, RRA, RBA, RFER, RDMA, RCL	$t_{PRA}$			75	ns	
Minimum $\overline{RST}$ Pulse Width	$t_{RST}$	1			$\mu s$	

**NOTES:**

1. Measured at  $V_{IH} = 2.0V$ ;  $V_{IL} = .8V$  and 10 ns maximum rise and fall times.
2. Output load capacitance = 100 pF.

**CAPACITANCE** $(t_A = 25^\circ C)$ 

PARAMETER	SYMBOL	MIN	TYP	MAX	UNITS	NOTES
Input Capacitance	$C_{IN}$			5	pF	
Output Capacitance	$C_{OUT}$			7	pF	

### TRANSMIT AC TIMING DIAGRAM Figure 30

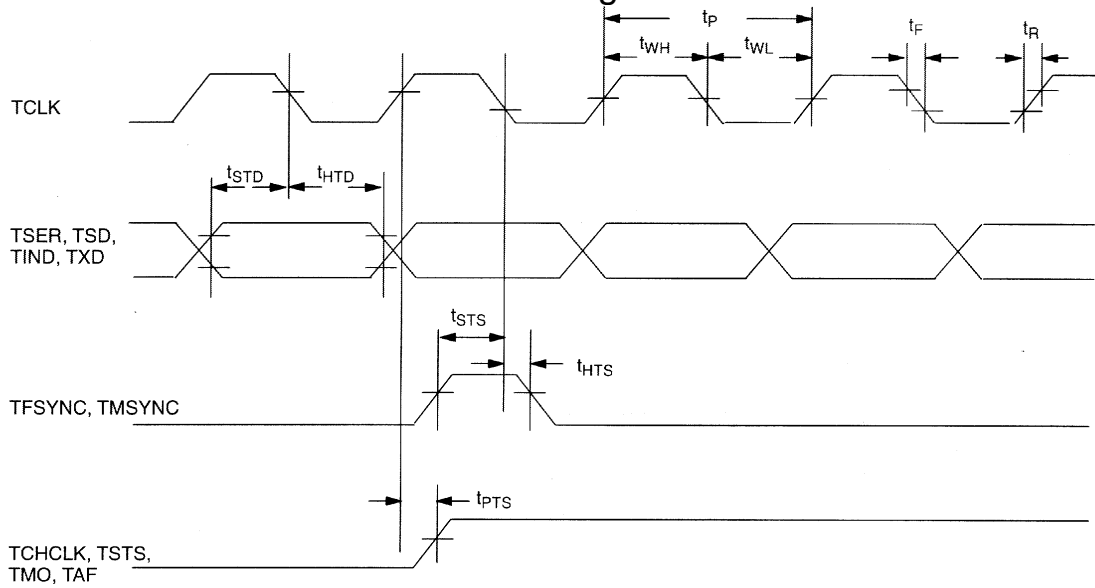

### RECEIVE AC TIMING DIAGRAM Figure 31

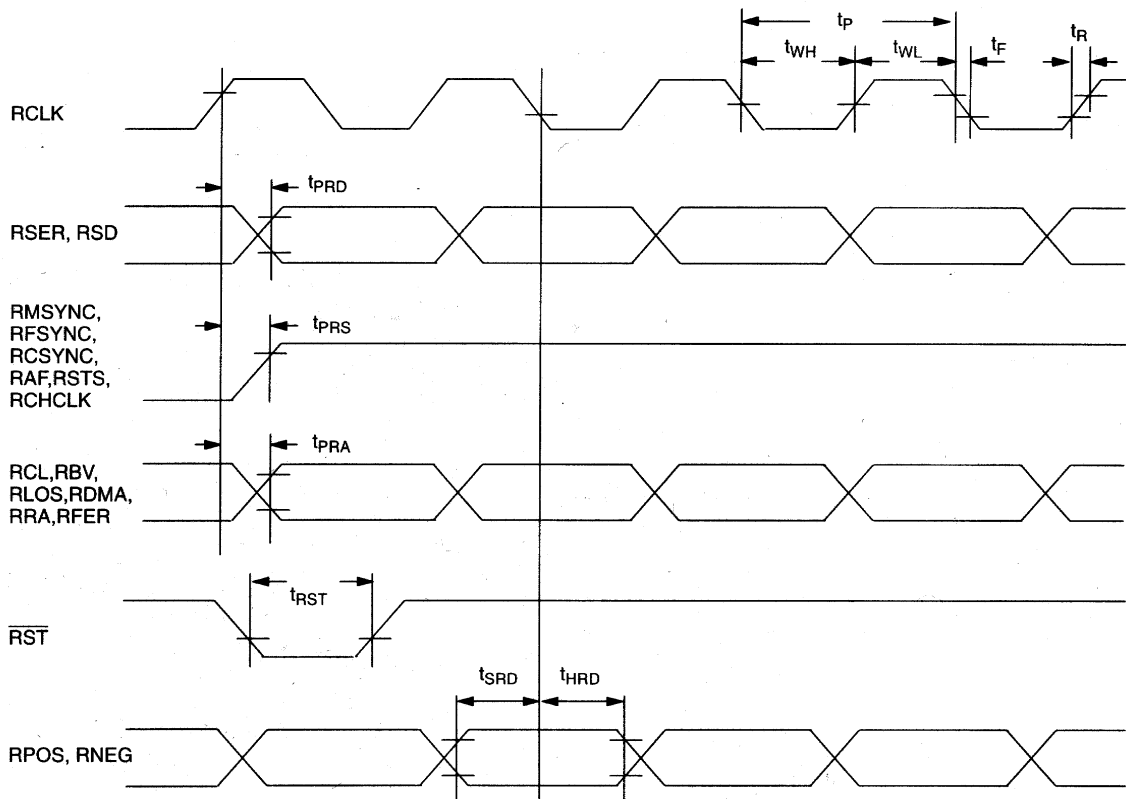

# DS2181A CEPT TRANSCEIVER (600-MIL DIP) 40-PIN

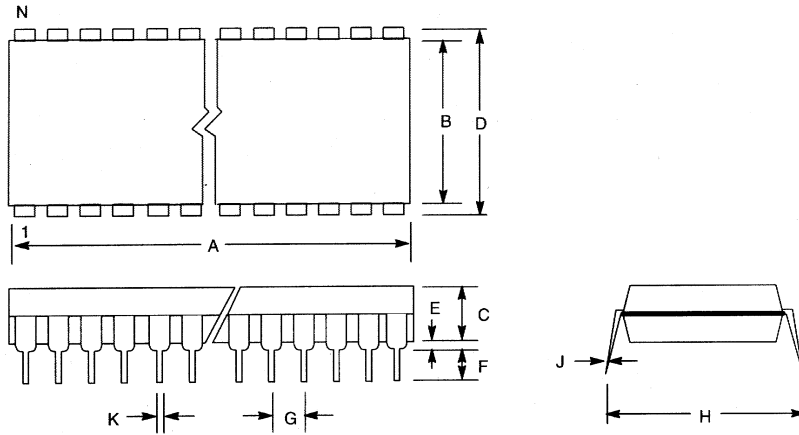

DIM	INCHES	
	MIN	MAX
A	2.050	2.075
B	0.530	0.550
C	0.140	0.160
D	0.600	0.625
E	0.015	0.040
F	0.120	0.145
G	0.090	0.110
H	0.625	0.675
J	0.008	0.012
K	0.015	0.022
N	40	

# DS2181AQ CEPT TRANSCEIVER (PLCC)

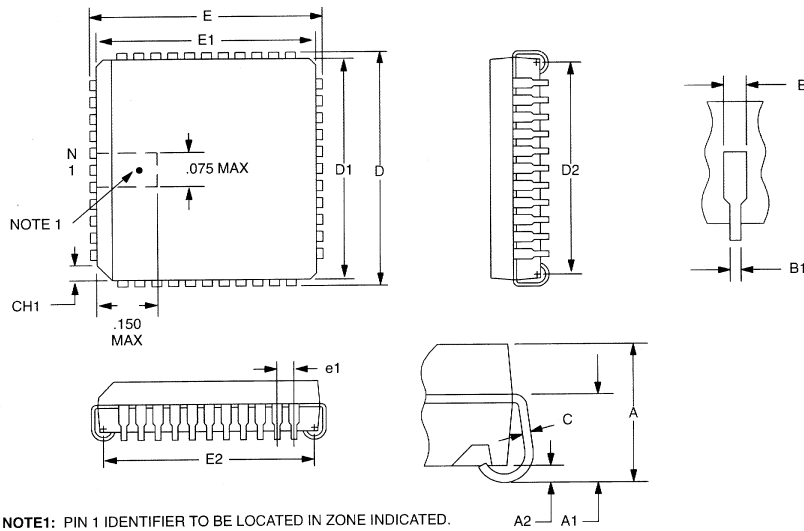

DIM	INCHES	
	MIN	MAX
A	0.165	0.180
A1	0.090	0.120
A2	0.020	-
B	0.026	0.033
B1	0.013	0.021
C	0.009	0.012
CH1	0.042	0.048
D	0.685	0.695
D1	0.650	0.656
D2	0.590	0.630
E	0.685	0.695
E1	0.650	0.656
E2	0.590	0.630
e1	0.050 BSC	
N	44	-