



# Industry-Standard High-Speed CAN Transceivers with $\pm 80V$ Fault Protection

## General Description

The MAX13050/MAX13052/MAX13053/MAX13054 are pin-for-pin compatible, industry-standard, high-speed, control area network (CAN) transceivers with extended  $\pm 80V$  fault protection. These products are ideal automotive and industrial network applications where overvoltage protection is required. These CAN transceivers provide a link between the CAN protocol controller and the physical wires of the bus lines in a CAN. These devices can be used for +12V/+42V battery, automotive, and DeviceNet<sup>®</sup> applications, requiring data rates up to 1Mbps.

The CAN transceivers have an input common-mode range greater than  $\pm 12V$ , exceeding the ISO11898 specification of -2V to +7V, and feature  $\pm 8kV$  ESD protection, making these devices ideal for harsh automotive and industrial environments.

The CAN transceivers provide a dominant timeout function that prevents erroneous CAN controllers from clamping the bus to a dominant level if the TXD input is held low for greater than 1ms. The MAX13050/MAX13052 provide a SPLIT pin used to stabilize the recessive common-mode voltage. The MAX13052 also has a slope-control mode that can be used to program the slew rate of the transmitter for data rates of up to 500kbps. The MAX13053 features a silent mode that disables the transmitter. The MAX13053 also has a reference output that can be used to bias the input of older CAN controllers that have a differential comparator. The MAX13054 has a separate dedicated logic input, VCC2, allowing interfacing with a +3.3V microcontroller.

The MAX13050/MAX13052/MAX13053/MAX13054 are available in an 8-pin SO package and are specified to operate in the -40°C to +85°C and the -40°C to +125°C temperature ranges.

## Applications

+12V and +42V Automotive	Medium- and Heavy-Duty Truck Systems
DeviceNet Nodes	Industrial

## Features

- ◆ Fully Compatible with the ISO11898 Standard
- ◆  $\pm 8kV$  ESD IEC 61000-4-2 Contact Discharge per IBEE Test Facility
- ◆  $\pm 80V$  Fault Protection
- ◆ +3.3V Logic Compatible (MAX13054)
- ◆ High-Speed Operation of Up to 1Mbps
- ◆ Slope-Control Mode (MAX13052)
- ◆ Greater than  $\pm 12V$  Common-Mode Range
- ◆ Low-Current Standby Mode
- ◆ Silent Mode (MAX13053)
- ◆ Thermal Shutdown
- ◆ Short-Circuit Protection
- ◆ Transmit (TXD) Data Dominant Timeout
- ◆ Current Limiting
- ◆ SPLIT Pin (MAX13050/MAX13052)

## Ordering Information

PART	TEMP RANGE	PIN-PACKAGE
MAX13050ESA	-40°C to +85°C	8 SO
MAX13050ASA/AUT*	-40°C to +125°C	8 SO
MAX13052ESA	-40°C to +85°C	8 SO
MAX13052ASA/AUT*	-40°C to +125°C	8 SO
MAX13053ESA	-40°C to +85°C	8 SO
MAX13053ASA/AUT*	-40°C to +125°C	8 SO
MAX13054ESA	-40°C to +85°C	8 SO
MAX13054ASA/AUT*	-40°C to +125°C	8 SO

\*AUT denotes introduction to AECQ100 specifications.

**Pin Configurations, Functional Diagrams, and Typical Operating Circuits appear at end of data sheet.**

DeviceNet is a registered trademark of the Open DeviceNet Vendor Association.

## Selector Guide

PART	SPLIT	SLOPE CONTROL	STANDBY MODE	SILENT MODE	3.3V SUPPLY	REF	PIN-FOR-PIN REPLACEMENT
MAX13050	Yes	—	Yes	—	—	—	TJA1040
MAX13052	Yes	Yes	Yes	—	—	—	PCA82C250/5-1
MAX13053	—	—	—	Yes	—	Yes	TJA1050, AMIS-30660
MAX13054	—	—	Yes	—	Yes	—	TLE6250v33, CF163



**For pricing, delivery, and ordering information, please contact Maxim/Dallas Direct! at 1-888-629-4642, or visit Maxim's website at [www.maxim-ic.com](http://www.maxim-ic.com).**

# Industry-Standard High-Speed CAN Transceivers with $\pm 80V$ Fault Protection

## ABSOLUTE MAXIMUM RATINGS

$V_{CC}, V_{CC2}$ .....	-0.3V to +6V	Operating Temperature Range .....	-40°C to +125°C
RS .....	-0.3V to ( $V_{CC} + 0.3V$ )	Junction Temperature .....	+150°C
TXD, STBY, S, REF, RXD .....	-0.3V to +6V	Storage Temperature Range .....	-65°C to +150°C
CANH, CANL, SPLIT .....	$\pm 80V$	Lead Temperature (soldering, 10s) .....	+300°C
Continuous Power Dissipation ( $T_A = +70^\circ C$ )			
8-Pin SO (derate 5.9mW/°C above +70°C) .....	470mW		

Stresses beyond those listed under "Absolute Maximum Ratings" may cause permanent damage to the device. These are stress ratings only, and functional operation of the device at these or any other conditions beyond those indicated in the operational sections of the specifications is not implied. Exposure to absolute maximum rating conditions for extended periods may affect device reliability.

## DC ELECTRICAL CHARACTERISTICS

( $V_{CC} = +5V \pm 5\%$ ,  $V_{CC2} = +3V$  to +3.6V,  $T_A = T_{MIN}$  to  $T_{MAX}$ , unless otherwise noted. Typical values are at  $V_{CC} = +5V$ ,  $V_{CC2} = +3.3V$ ,  $R_L = 60\Omega$ , and  $T_A = +25^\circ C$ .) (Note 1)

PARAMETER	SYMBOL	CONDITIONS	MIN	TYP	MAX	UNITS
V <sub>CC</sub> Supply Current	I <sub>CC</sub>	Dominant, $R_L = 60\Omega$			72	mA
		Recessive	MAX13050/MAX13052/ MAX13053		12.5	
			MAX13054		10	
V <sub>CC2</sub> Supply Current	I <sub>CC2</sub>	MAX13054, TXD = V <sub>CC2</sub> or floating			15	$\mu A$
Standby Current	I <sub>STANDBY</sub>	MAX13052			25	$\mu A$
		MAX13050/MAX13054			11	
Silent Mode	I <sub>SILENT</sub>	MAX13053			12.5	mA
Thermal-Shutdown Threshold	T <sub>SH</sub>			+165		°C
Thermal-Shutdown Hysteresis				13		°C
<b>INPUT LEVELS (TXD, STBY, S)</b>						
High-Level Input Voltage	V <sub>IH</sub>		2			V
		TXD, STBY (MAX13054)	0.7 x		V <sub>CC2</sub>	
Low-Level Input Voltage	V <sub>IL</sub>			0.8		V
		TXD, STBY (MAX13054)		0.3 x	V <sub>CC2</sub>	
High-Level Input Current	I <sub>IH</sub>	V <sub>TXD</sub> = V <sub>CC</sub> , V <sub>TXD</sub> = V <sub>CC2</sub> (MAX13054)	-5		+5	$\mu A$
		V <sub>STBY</sub> = V <sub>CC</sub> , V <sub>S</sub> = V <sub>CC</sub> (MAX13053)	-5		+5	
Low-Level Input Current	I <sub>IL</sub>	V <sub>TXD</sub> = GND	-300		-100	$\mu A$
		V <sub>STBY</sub> = GND, V <sub>S</sub> = GND (MAX13053)	-10		-1	
Input Capacitance	C <sub>IN</sub>			10		pF
<b>CANH, CANL TRANSMITTER</b>						
Recessive Bus Voltage	V <sub>CANH</sub> , V <sub>CANL</sub>	Normal mode, V <sub>TXD</sub> = V <sub>CC</sub> , no load	2		3	V
		Standby mode, no load	-100		+100	mV
Recessive Output Current	I <sub>CANH</sub> , I <sub>CANL</sub>	V <sub>CANH</sub> , V <sub>CANL</sub> = $\pm 76V$		$\pm 3$		mA
		-32V $\leq$ V <sub>CANH</sub> , V <sub>CANL</sub> $\leq$ +32V	-2.5		+2.5	
CANH Output Voltage	V <sub>CANH</sub>	V <sub>TXD</sub> = 0, dominant	3.0		4.25	V
CANL Output Voltage	V <sub>CANL</sub>	V <sub>TXD</sub> = 0, dominant	0.50		1.75	V
Matching Between CANH and CANL Output Voltage	$\Delta DOM$	V <sub>TXD</sub> = 0, dominant, $T_A = +25^\circ C$ , (V <sub>CANH</sub> + V <sub>CANL</sub> ) - V <sub>CC</sub>	-100		+150	mV

# Industry-Standard High-Speed CAN Transceivers with $\pm 80V$ Fault Protection

## DC ELECTRICAL CHARACTERISTICS (continued)

( $V_{CC} = +5V \pm 5\%$ ,  $V_{CC2} = +3V$  to  $+3.6V$ ,  $T_A = T_{MIN}$  to  $T_{MAX}$ , unless otherwise noted. Typical values are at  $V_{CC} = +5V$ ,  $V_{CC2} = +3.3V$ ,  $R_L = 60\Omega$ , and  $T_A = +25^\circ C$ .) (Note 1)

PARAMETER	SYMBOL	CONDITIONS	MIN	TYP	MAX	UNITS
Differential Output ( $V_{CANH} - V_{CANL}$ )	$V_{DIFF}$	Dominant, $V_{TXD} = 0$ , $45\Omega \leq R_L \leq 60\Omega$	1.5		3.0	V
		Recessive, $V_{TXD} = V_{CC}$ , no load	-50		+50	mV
CANH Short-Circuit Current	$I_{CANHSC}$	$V_{CANH} = 0$ , $V_{TXD} = 0$	-100	-70	-45	mA
CANL Short-Circuit Current	$I_{CANLSC}$	$V_{CANL} = 5V$ , $V_{TXD} = 0$	40	60	90	mA
		$V_{CANL} = 40V$ , $V_{TXD} = 0$ (Note 2)	40	60	90	
		$V_{CANL} = 76V$ , $V_{TXD} = 0$		63		
<b>RXD OUTPUT LEVELS</b>						
RXD High-Output-Voltage Level	$V_{OH}$	$I = -100\mu A$	$0.8 \times V_{CC}$		$V_{CC}$	V
		$I = -100\mu A$ (MAX13054)	$0.8 \times V_{CC2}$		$V_{CC2}$	
RXD Low-Output-Voltage Level	$V_{OL}$	$I = 5mA$			0.4	V
<b>COMMON-MODE STABILIZATION (SPLIT) and REF</b>						
Output Voltage	$V_{SPLIT}$	Normal mode, $-500\mu A \leq I_{SPLIT} \leq 500\mu A$	$0.3 \times V_{CC}$		$0.7 \times V_{CC}$	V
Leakage Current	$I_{LEAK}$	Standby mode, $-40V \leq V_{SPLIT} \leq +40V$			20	$\mu A$
		Standby mode, $-76V \leq V_{SPLIT} \leq +76V$			50	
REF Output Voltage	$V_{REF}$	$-50\mu A \leq I_{REF} \leq +50\mu A$ (MAX13053)	$0.45 \times V_{CC}$		$0.55 \times V_{CC}$	V
<b>DC BUS RECEIVER (<math>V_{TXD} = V_{CC}</math>, CANH and CANL externally driven)</b>						
Differential Input Voltage	$V_{DIFF}$	$-12V \leq V_{CM} \leq +12V$	0.5	0.7	0.9	V
		MAX13050/MAX13052/MAX13054 $-12V \leq V_{CM} \leq +12V$ (standby mode)	0.50		1.15	
Differential Input Hysteresis	$V_{DIFF(HYST)}$	Normal mode, $-12V \leq V_{CM} \leq +12V$		70		mV
Common-Mode Input Resistance	$R_{ICM}$	Normal or standby mode, $V_{CANH} = V_{CANL} = \pm 12V$	15		35	k $\Omega$
Matching Between CANH and CANL Common-Mode Input Resistance	$R_{IC\_MATCH}$	$V_{CANH} = V_{CANL}$	-3		+3	%
Differential Input Resistance	$R_{DIFF}$	Normal or standby mode, $V_{CANH} - V_{CANL} = 1V$	25		75	k $\Omega$
Common-Mode Input Capacitance	$C_{IM}$	$V_{TXD} = V_{CC}$		20		pF
Differential Input Capacitance		$V_{TXD} = V_{CC}$		10		pF
Input Leakage Current	$I_{LI}$	$V_{CC} = 0$ , $V_{CANH} = V_{CANL} = 5V$	-5		+5	$\mu A$
<b>SLOPE CONTROL RS (MAX13052)</b>						
Input Voltage for High Speed	$V_{IL\_RS}$				$0.3 \times V_{CC}$	V

MAX13050/MAX13052/MAX13053/MAX13054

# Industry-Standard High-Speed CAN Transceivers with $\pm 80V$ Fault Protection

## DC ELECTRICAL CHARACTERISTICS (continued)

( $V_{CC} = +5V \pm 5\%$ ,  $V_{CC2} = +3V$  to  $+3.6V$ ,  $T_A = T_{MIN}$  to  $T_{MAX}$ , unless otherwise noted. Typical values are at  $V_{CC} = +5V$ ,  $V_{CC2} = +3.3V$ ,  $R_L = 60\Omega$ , and  $T_A = +25^\circ C$ .) (Note 1)

PARAMETER	SYMBOL	CONDITIONS	MIN	TYP	MAX	UNITS
Input Voltage for Standby	$V_{IH\_RS}$		$0.75 \times V_{CC}$			V
Slope-Control Mode Voltage	$V_{SLOPE}$	$-200\mu A < I_{RS} < 10\mu A$	$0.4 \times V_{CC}$		$0.6 \times V_{CC}$	V
High-Speed Mode Current	$I_{IL\_RS}$	$V_{RS} = 0$	-500			$\mu A$
ESD Protection		IEC 61000-4-2 Contact Discharge Method per IBEE test facility (Note 3)		$\pm 8$		kV

## TIMING CHARACTERISTICS

( $V_{CC} = +5V \pm 5\%$ ,  $V_{CC2} = +3V$  to  $+3.6V$ ,  $R_L = 60\Omega$ ,  $C_L = 100pF$ ,  $T_A = T_{MIN}$  to  $T_{MAX}$ , unless otherwise noted. Typical values are at  $V_{CC} = +5V$ ,  $V_{CC2} = +3.3V$ , and  $T_A = +25^\circ C$ .)

PARAMETER	SYMBOL	CONDITIONS		MIN	TYP	MAX	UNITS
Delay TXD to Bus Active	$t_{ONTXD}$	Figure 1 (Note 4)			66	110	ns
Delay TXD to Bus Inactive	$t_{OFFTXD}$	Figure 1 (Note 4)	MAX13050/MAX13052/ MAX13053		61	95	ns
			MAX13054		70	110	
Delay Bus to Receiver Active	$t_{ONRXD}$	Figure 1 (Note 4)			54	115	ns
Delay Bus to Receiver Inactive	$t_{OFFRXD}$	Figure 1 (Note 4)			46	160	ns
Delay TXD to RXD Active (Dominant Loop Delay)	$t_{ONLOOP}$	Figure 1 (Note 4)			121	255	ns
Delay TXD to RXD Inactive (Recessive Loop Delay)	$t_{OFFLOOP}$	Figure 4 (Note 4)			108	255	ns
Delay TXD to RXD Active (Dominant Loop Delay) Slew-Rate Controlled	$t_{ONLOOP-S}$	MAX13052	$R_{RS} = 24k\Omega$ (500kbps)		280	450	$\mu s$
			$R_{RS} = 100k\Omega$ (125kbps)		0.82	1.6	
			$R_{RS} = 180k\Omega$ (62.5kbps)		1.37	5	
Delay TXD to RXD Inactive (Loop Delay) Slew-Rate Controlled	$t_{OFFLOOP-S}$	MAX13052	$R_{RS} = 24k\Omega$ (500kbps)		386	600	$\mu s$
			$R_{RS} = 100k\Omega$ (125kbps)		0.74	1.6	
			$R_{RS} = 180k\Omega$ (62.5kbps)		0.97	5	
Differential Output Slew Rate	ISRI	MAX13052	$R_{RS} = 24k\Omega$ (500kbps)		10		V/ $\mu s$
			$R_{RS} = 100k\Omega$ (125kbps)		2.7		
			$R_{RS} = 180k\Omega$ (62.5kbps)		1.6		

# Industry-Standard High-Speed CAN Transceivers with $\pm 80V$ Fault Protection

MAX13050/MAX13052/MAX13053/MAX13054

## TIMING CHARACTERISTICS (continued)

( $V_{CC} = +5V \pm 5\%$ ,  $V_{CC2} = +3V$  to  $+3.6V$ ,  $R_L = 60\Omega$ ,  $C_L = 100pF$ ,  $T_A = T_{MIN}$  to  $T_{MAX}$ , unless otherwise noted. Typical values are at  $V_{CC} = +5V$ ,  $V_{CC2} = +3.3V$ , and  $T_A = +25^\circ C$ .)

PARAMETER	SYMBOL	CONDITIONS	MIN	TYP	MAX	UNITS
Dominant Time for Wake-Up with Bus	$t_{WAKE}$	Standby mode, $V_{DIFF} = +3V$ , Figure 2	0.75	1.5	3.00	$\mu s$
Delay STBY to Normal Mode (DOMINANT)	$t_{STBY-NORM}$	$TXD = 0$ (MAX13050, MAX13054) FROM STBY falling to $CANH - CANL = 0.9V$	5		10	$\mu s$
TXD Dominant Timeout	$t_{DOM}$	$V_{TXD} = 0$	0.3	0.6	1.0	ms

**Note 1:** All currents into the device are positive, all currents out of the device are negative. All voltages are referenced to the device ground, unless otherwise noted.

**Note 2:** Guaranteed by design, not production tested.

**Note 3:** MAX13050 tested by IBEE test facility. Please contact factory for report. MAX13052/MAX13053/MAX13054 are pending ESD evaluation.

**Note 4:** For the MAX13052,  $V_{RS} = 0$ .

## Timing Diagrams

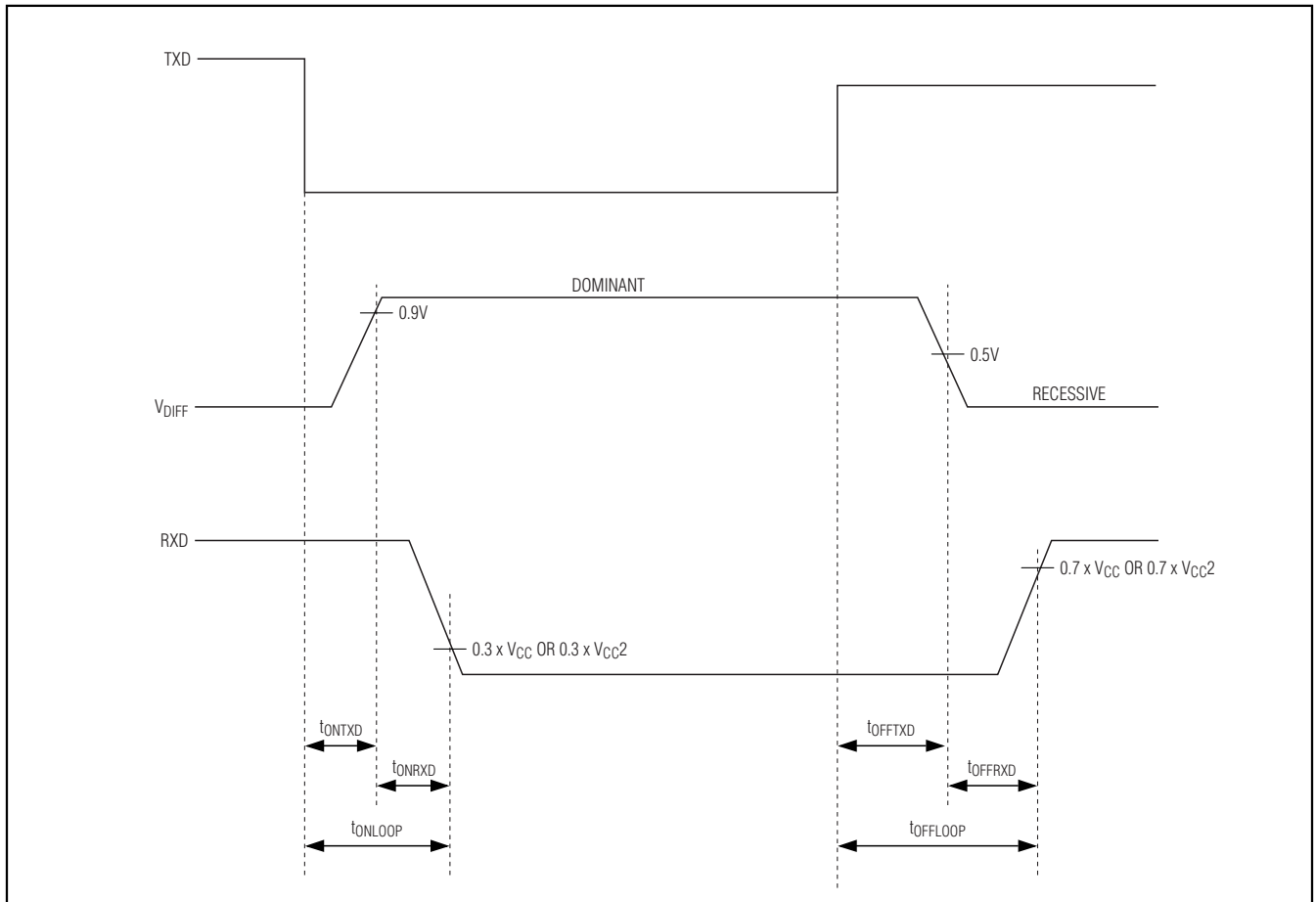

Figure 1. Timing Diagram

# Industry-Standard High-Speed CAN Transceivers with $\pm 80V$ Fault Protection

## Timing Diagrams

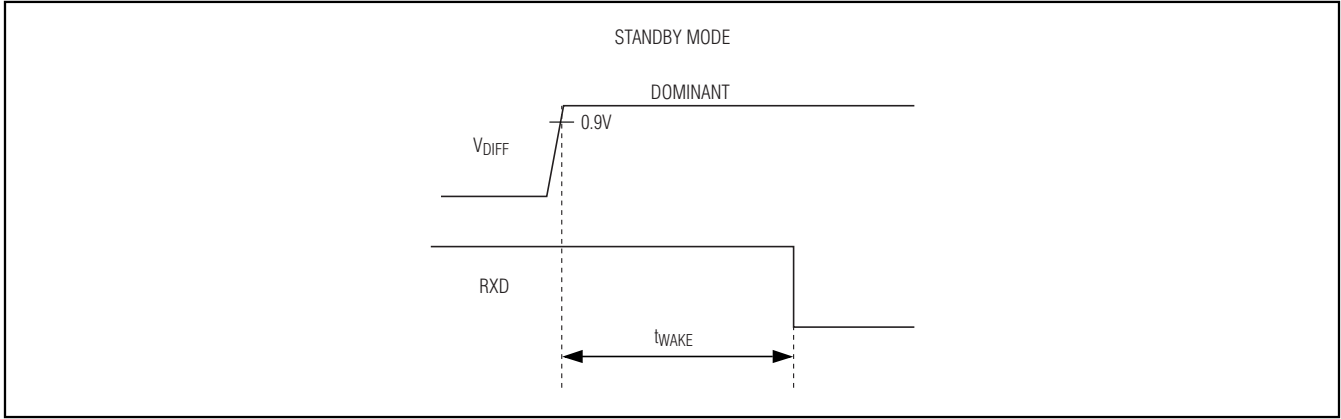
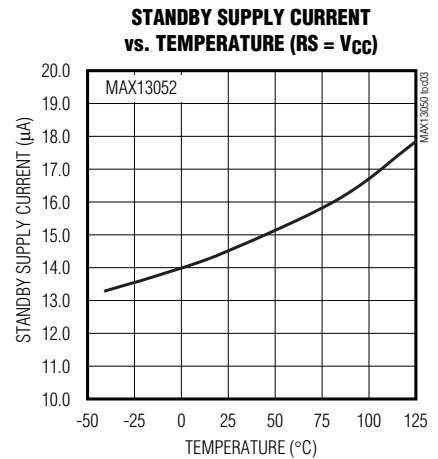
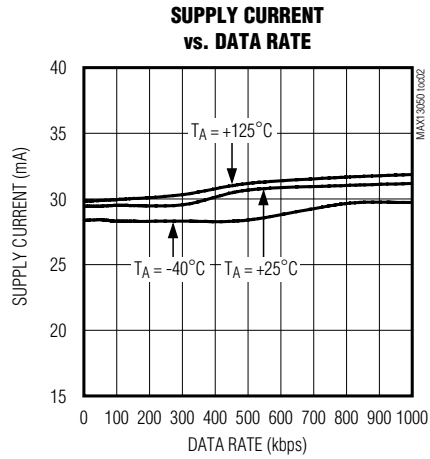
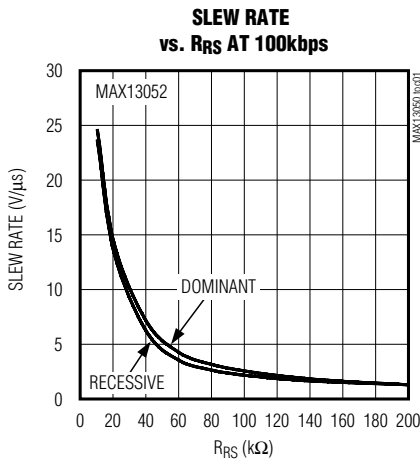

Figure 2. Timing Diagram for Standby and Wake-Up Signal

## Typical Operating Characteristics

( $V_{CC} = +5V$ ,  $R_L = 60\Omega$ ,  $C_L = 100pF$ ,  $V_{CC2} = +3.3V$ , and  $T_A = +25^\circ C$ , unless otherwise noted.)



# Industry-Standard High-Speed CAN Transceivers with $\pm 80V$ Fault Protection

## Typical Operating Characteristics

( $V_{CC} = +5V$ ,  $R_L = 60\Omega$ ,  $C_L = 100pF$ ,  $V_{CC2} = +3.3V$ , and  $T_A = +25^\circ C$ , unless otherwise noted.)

MAX13050/MAX13052/MAX13053/MAX13054

**STANDBY SUPPLY CURRENT vs. TEMPERATURE (STBY =  $V_{CC}$ )**

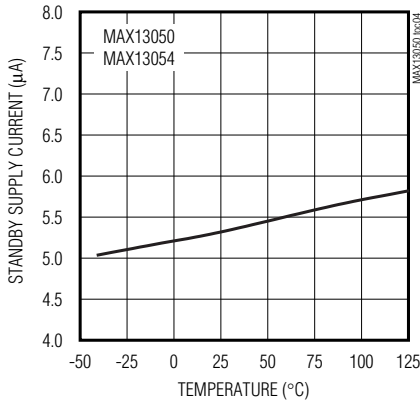

**RECEIVER PROPAGATION DELAY vs. TEMPERATURE**

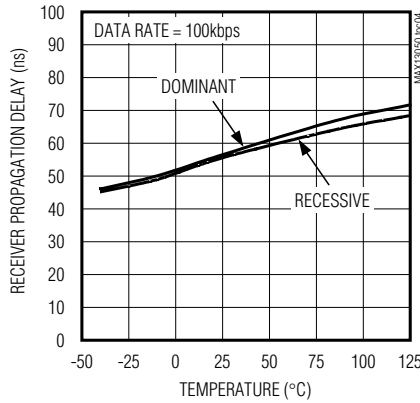

**DRIVER PROPAGATION DELAY vs. TEMPERATURE**

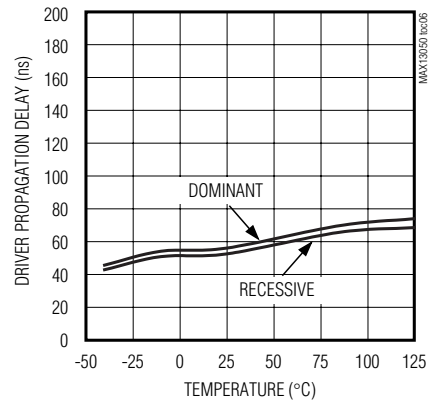

**REF VOLTAGE vs. REG OUTPUT CURRENT**

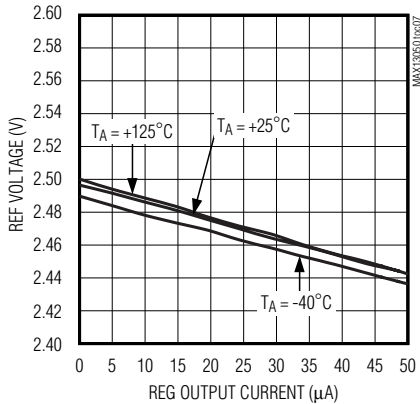

**SPLIT LEAKAGE CURRENT vs. TEMPERATURE**

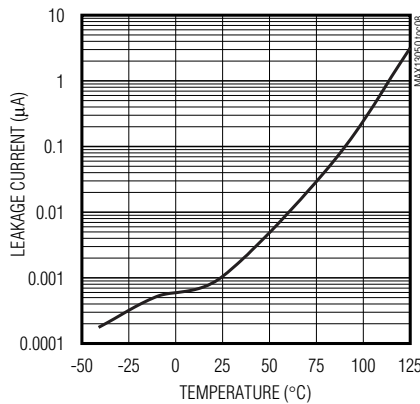

**RECEIVER OUTPUT LOW vs. OUTPUT CURRENT**

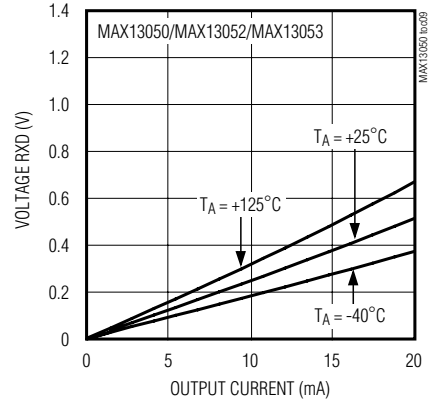

**RECEIVER OUTPUT HIGH vs. OUTPUT CURRENT**

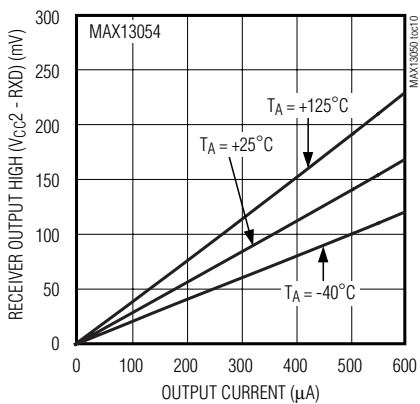

**RECEIVER OUTPUT HIGH vs. OUTPUT CURRENT**

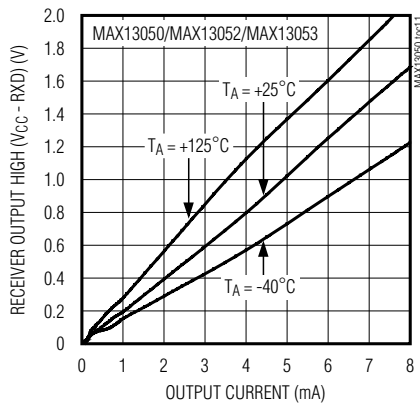

**RECEIVER OUTPUT LOW vs. OUTPUT CURRENT**

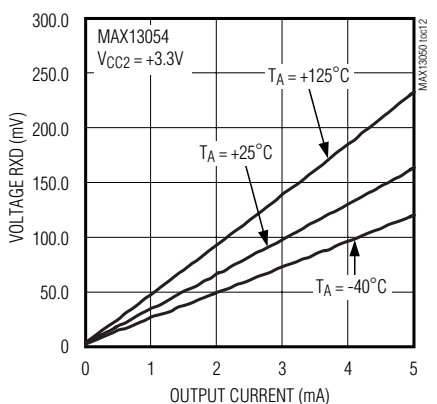

# Industry-Standard High-Speed CAN Transceivers with $\pm 80V$ Fault Protection

## Typical Operating Characteristics (continued)

( $V_{CC} = +5V$ ,  $R_L = 60\Omega$ ,  $C_L = 100pF$ ,  $V_{CC2} = +3.3V$ , and  $T_A = +25^\circ C$ , unless otherwise noted.)

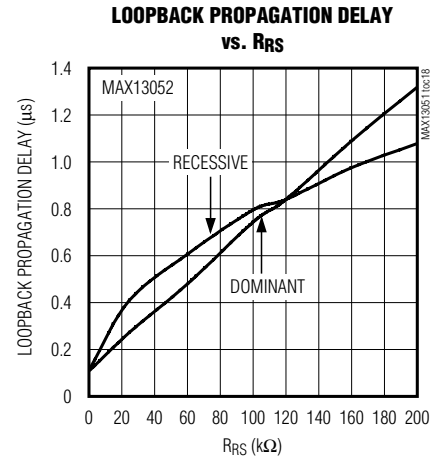
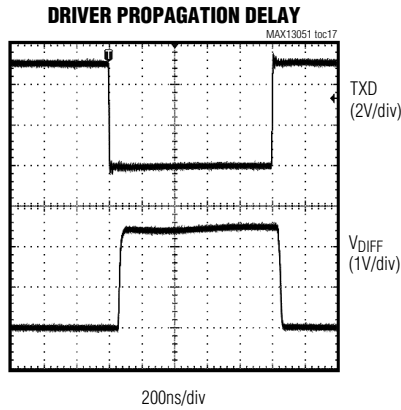
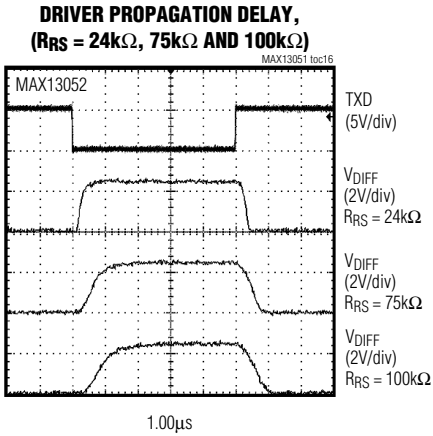
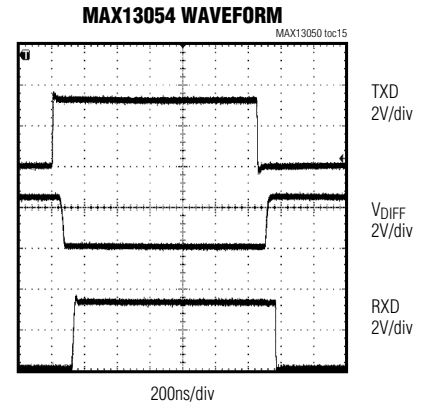
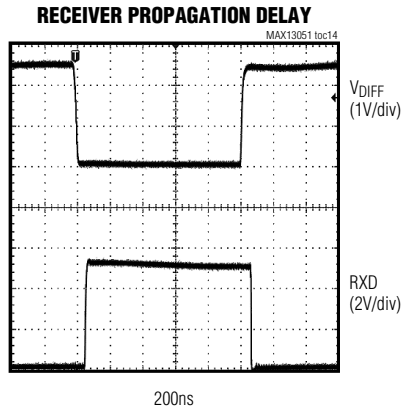
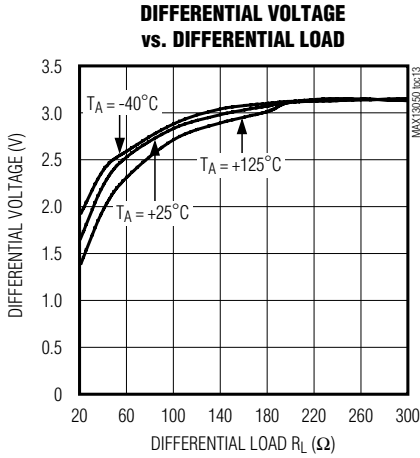



# Industry-Standard High-Speed CAN Transceivers with $\pm 80V$ Fault Protection

## Pin Description

PIN				NAME	FUNCTION
MAX13050	MAX13052	MAX13053	MAX13054		
1	1	1	1	TXD	Transmit Data Input. TXD is a CMOS/TTL-compatible input from a CAN controller with a 25k $\Omega$ pullup to V <sub>CC</sub> . For the MAX13054, TXD is pulled to V <sub>CC2</sub> .
2	2	2	2	GND	Ground
3	3	3	3	V <sub>CC</sub>	Supply Voltage. Bypass V <sub>CC</sub> to GND with a 0.1 $\mu$ F capacitor.
4	4	4	4	RXD	Receive Data Output. RXD is a CMOS/TTL-compatible output from the physical bus lines CANH and CANL. For the MAX13054, RXD output voltage is referenced to the V <sub>CC2</sub> supply voltage.
5	5	—	—	SPLIT	Common-Mode Stabilization Output. Output equaled to 0.5 x V <sub>CC</sub> . SPLIT goes high impedance in standby mode .
6	6	6	6	CANL	CAN Bus-Line Low
7	7	7	7	CANH	CAN Bus-Line High
8	—	—	8	STBY	Standby Input. Drive STBY low for high-speed operation. Drive STBY high to place the device in low-current standby mode.
—	8	—	—	RS	Mode-Select Input. Drive RS low or connect to GND for high-speed operation. Connect a resistor between RS and GND to control output slope. Drive RS high to put into standby mode.
—	—	5	—	REF	Reference Output Voltage. Always on reference output voltage, set to 0.5 x V <sub>CC</sub> .
—	—	8	—	S	Silent-Mode Input. Drive S low to enable TXD and to operate in high-speed mode. Drive S high to disable the transmitter.
—	—	—	5	V <sub>CC2</sub>	Logic-Supply Input. V <sub>CC2</sub> is the logic supply voltage for the input/output between the CAN transceiver and microprocessor. V <sub>CC2</sub> allows fully compatible +3.3V logic on all digital lines. Bypass to GND with a 0.1 $\mu$ F capacitor. Connect V <sub>CC2</sub> to V <sub>CC</sub> for 5V logic compatibility.

### Detailed Description

The MAX13050/MAX13052/MAX13053/MAX13054  $\pm 80V$  fault-protected CAN transceivers are ideal for automotive and industrial network applications where overvoltage protection is required. These devices provide a link between the CAN protocol controller and the physical wires of the bus lines in a control area network (CAN). These devices can be used for +12V and +42V battery automotive and DeviceNet applications, requiring data rates up to 1Mbps.

The MAX13050/MAX13052/MAX13053/MAX13054 dominant timeout prevents the bus from being blocked

by a hung-up microcontroller. If the TXD input is held low for greater than 1ms, the transmitter becomes disabled, driving the bus line to a recessive state. The MAX13054 +3.3V logic input allows the device to communicate with +3.3V logic, while operating from a +5V supply. The MAX13050 and MAX13052 provide a split DC-stabilized voltage. The MAX13053 has a reference output that can be used to bias the input of a CAN controller's differential comparator.

All devices can operate up to 1Mbps (high-speed mode). The MAX13052 slope-control feature allows the user to program the slew rate of the transmitter for data

MAX13050/MAX13052/MAX13053/MAX13054

# Industry-Standard High-Speed CAN Transceivers with $\pm 80V$ Fault Protection

rates of up to 500kbps. This reduces the effects of EMI, thus allowing the use of unshielded-twisted or parallel cable. The MAX13050/MAX13052 and MAX13054 standby mode shuts off the transmitter and switches the receiver to a low-current/low-speed state.

The MAX13050/MAX13052/MAX13053/MAX13054 input common-mode range is greater than  $\pm 12V$ , exceeding the ISO11898 specification of  $-2V$  to  $+7V$ , and feature  $\pm 8kV$  Contact Discharge protection, making these devices ideal for harsh automotive and industrial environments.

## **$\pm 80V$ Fault Protected**

The MAX13050/MAX13052/MAX13053/MAX13054 feature  $\pm 80V$  fault protection. This extended voltage range of CANH, CANL, and SPLIT allows use in high-voltage systems and communication with high-voltage buses.

## **Operating Modes**

### **High-Speed Mode**

The MAX13050/MAX13052/MAX13053/MAX13054 can achieve transmission rates of up to 1Mbps when operating in high-speed mode. Drive STBY low to operate the MAX13050 and MAX13054 in high-speed operation. Connect RS to ground to operate the MAX13052 in high-speed mode.

### **Slope-Control Mode (MAX13052)**

Connect a resistor from RS to ground to select slope-control mode (Table 1). In slope-control mode, CANH and CANL slew rates are controlled by the resistor ( $16k\Omega \leq R_{RS} \leq 200k\Omega$ ) connected between RS and GND. Controlling the rise and fall slopes reduces high-frequency EMI and allows the use of an unshielded-twisted pair or a parallel pair of wires as bus lines. The slew rate can be approximated using the formula below:

$$SR(V/\mu s) = \frac{250}{R_{RS}}$$

where, SR is the desired slew rate and  $R_{RS}$  is in  $k\Omega$ .

### **Standby Mode (MAX13050/MAX13052/MAX13054)**

In standby mode (RS or STBY = high), the transmitter is switched off and the receiver is switched to a low-current/low-speed state. The supply current is reduced during standby mode. The bus line is monitored by a low-differential comparator to detect and recognize a wake-up event on the bus line. Once the comparator detects a dominant bus level greater than  $t_{WAKE}$ , RXD pulls low.

**Table 1. Mode Selection Truth Table  
MAX13052**

CONDITION FORCED AT RS	MODE	RESULTING CURRENT AT RS
$V_{RS} \text{ or } \leq 0.3 \times V_{CC}$	High-Speed	$ I_{RS}  \leq 500\mu A$
$0.4 \times V_{CC} \leq V_{RS} \leq 0.6 \times V_{CC}$	Slope Control	$10\mu A \leq  I_{RS}  \leq 200\mu A$
$V_{RS} \geq 0.75 \times V_{CC}$	Standby	$ I_{RS}  \leq 10\mu A$

Drive STBY high for standby mode operation for the MAX13050 and MAX13054. Apply a logic-high to RS to enter a low-current standby mode for the MAX13052.

### **Silent Mode S (MAX13053)**

Drive S high to place the MAX13053 in silent mode. When operating in silent mode, the transmitter is disabled regardless of the voltage level at TXD. RXD however, still monitors activity on the bus line.

### **Common-Mode Stabilization (SPLIT)**

SPLIT provides a DC common-mode stabilization voltage of  $0.5 \times V_{CC}$  when operating in normal mode. SPLIT stabilizes the recessive voltage to  $0.5 \times V_{CC}$  for conditions when the recessive bus voltage is lowered, caused by an unpowered transceiver in the network with a significant leakage current from the bus lines to ground. Use SPLIT to stabilize the recessive common-mode voltage by connecting SPLIT to the center tap of the split termination, see the *Typical Operating Circuit*. In standby mode or when  $V_{CC} = 0$ , SPLIT becomes high impedance.

### **Reference Output (MAX13053)**

MAX13053 has a reference voltage output (REF) set to  $0.5 \times V_{CC}$ . REF can be utilized to bias the input of a CAN controller's differential comparator, and to provide power to external circuitry.

### **Transmitter**

The transmitter converts a single-ended input (TXD) from the CAN controller to differential outputs for the bus lines (CANH, CANL). The truth table for the transmitter and receiver is given in Table 2.

### **TXD Dominant Timeout**

The CAN transceivers provide a transmitter dominant timeout function that prevents erroneous CAN controllers from clamping the bus to a dominant level by a continuous low TXD signal. When the TXD remains low for the 1ms maximum timeout period, the transmitter becomes disabled, thus driving the bus line to a recessive state

# Industry-Standard High-Speed CAN Transceivers with $\pm 80V$ Fault Protection

MAX13050/MAX13052/MAX13053/MAX13054

**Table 2. Transmitter and Receiver Truth Table (MAX13052)**

TXD	RS	CANH	CANL	BUS STATE	RXD
Low	$V_{RS} \leq 0.75 \times V_{CC}$	High	Low	Dominant	Low
High or Float	$V_{RS} \leq 0.75 \times V_{CC}$	$V_{CC} / 2$	$V_{CC} / 2$	Recessive	High
X	$V_{RS} \geq 0.75 \times V_{CC}$	R <sub>ICM</sub> to GND	R <sub>ICM</sub> to GND	Recessive	High

**Table 3. Transmitter and Receiver Truth Table (MAX13053)**

TXD	RS	CANH	CANL	BUS STATE	RXD
Low	$V_S < 0.8V$	High	Low	Dominant	Low
High or Float	$V_S < 0.8V$	$V_{CC} / 2$	$V_{CC} / 2$	Recessive	High
X	$V_S > 2V$	$V_{CC} / 2$	$V_{CC} / 2$	Recessive	High

**(MAX13050/MAX13054)**

TXD	STBY	CANH	CANL	BUS STATE	RXD
Low	$V_{STBY} \leq 0.8V$ $*V_{STBY} \leq 0.3 \times V_{CC2}$	High	Low	Dominant	Low
High or Float	$V_{STBY} \leq 0.8V$ $*V_{STBY} \leq 0.3 \times V_{CC2}$	$V_{CC} / 2$	$V_{CC} / 2$	Recessive	High
X	$V_{STBY} \geq 2V$ $*V_{STBY} \geq 0.7 \times V_{CC2}$	R <sub>ICM</sub> to GND	R <sub>ICM</sub> to GND	Recessive	High

\*For the MAX13054

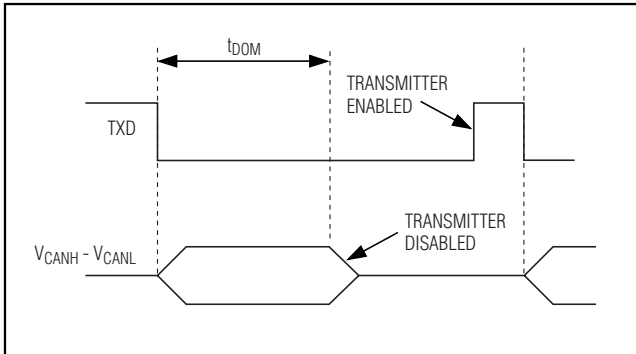

Figure 3. Transmitter Dominant Timeout Timing Diagram

(Figure 3). The transmitter becomes enabled upon detecting a rising edge at TXD.

### Receiver

The receiver reads differential inputs from the bus lines (CANH, CANL) and transfers this data as a single-ended output (RXD) to the CAN controller. It consists of a comparator that senses the difference  $V_{DIFF} = (CANH - CANL)$  with respect to an internal threshold of 0.7V. If this difference is positive (i.e.,  $V_{DIFF} > 0.7$ ), a logic-low is present at RXD. If negative (i.e.,  $V_{DIFF} < 0.7$ ), a logic-high is present.

The CANH and CANL common-mode range is greater than  $\pm 12V$ . RXD is logic-high when CANH and CANL are shorted or terminated and undriven.

### +3.3V Logic Compatibility (MAX13054)

A separate input, V<sub>CC2</sub>, allows the MAX13054 to communicate with +3.3V logic systems while operating from a +5V supply. This provides a reduced input voltage threshold to the TXD and STBY inputs, and provides a logic-high output at RXD compatible with the microcontroller's system voltage. The logic compatibility eliminates longer propagation delay due to level shifting. Connect V<sub>CC2</sub> to V<sub>CC</sub> to operate the MAX13054 with +5V logic systems.

### Driver Output Protection

The current-limiting feature protects the transmitter output stage against a short circuit to a positive and negative battery voltage. Although the power dissipation increases during this fault condition, current-limit protection prevents destruction of the transmitter output stage. Upon removal of a short, the CAN transceiver resumes normal operation.

### Thermal Shutdown

If the junction temperature exceeds +165°C, the driver is switched off. The hysteresis is approximately 13°C,

# Industry-Standard High-Speed CAN Transceivers with $\pm 80V$ Fault Protection

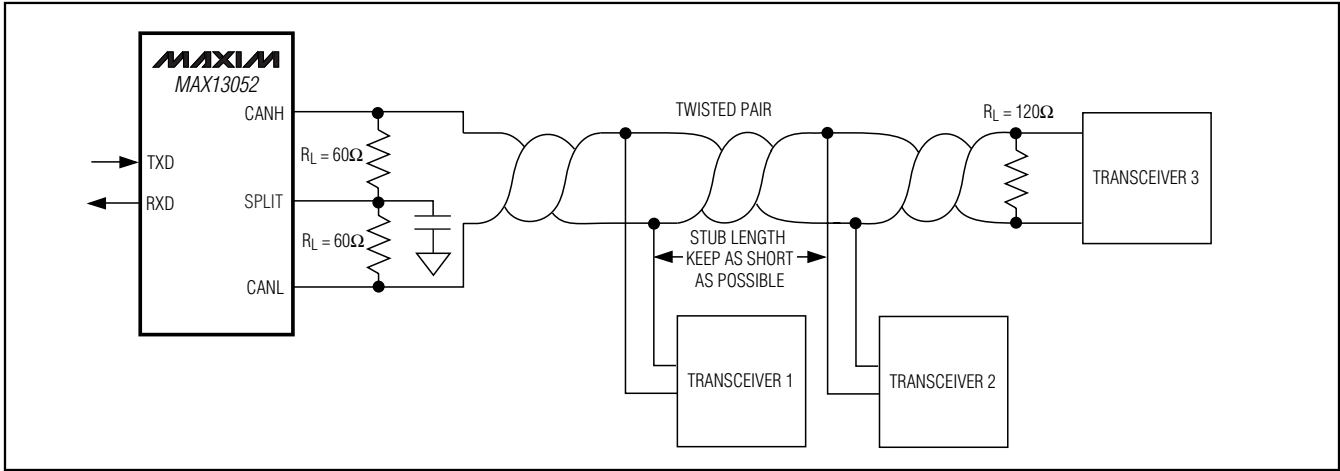

Figure 4. Multiple Receivers Connected to CAN Bus

disabling thermal shutdown once the temperature drops below  $+152^{\circ}\text{C}$ . In thermal shutdown, CANH and CANL go recessive. After a thermal-shutdown event, the IC resumes normal operation when the junction temperature drops below the thermal-shutdown hysteresis, and upon the CAN transceiver detecting a rising edge at TXD.

## Applications Information

### Reduced EMI and Reflections

In slope-control mode, the MAX13052's CANH and CANL outputs are slew-rate limited, minimizing EMI and reducing reflections caused by improperly terminated cables.

In multidrop CAN applications, it is important to maintain a direct point-to-point wiring scheme. A single pair of wires should connect each element of the CAN bus, and the two ends of the bus should be terminated with  $120\Omega$  resistors, see Figure 4. A star configuration should never be used.

Any deviation from the point-to-point wiring scheme creates a stub. The high-speed edge of the CAN data on a stub can create reflections back down the bus. These reflections can cause data errors by eroding the noise margin of the system.

Although stubs are unavoidable in a multidrop system, care should be taken to keep these stubs as small as possible, especially in high-speed mode. In slope-control mode, the requirements are not as rigorous, but stub length should still be minimized.

### Layout Consideration

CANH and CANL are differential signals and steps should be taken to insure equivalent parasitic capaci-

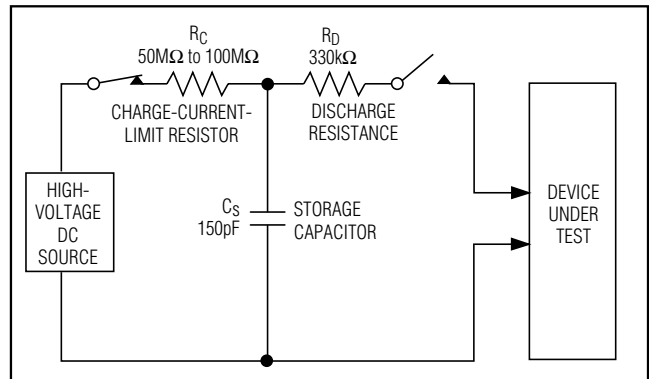

Figure 5. IEC 61000-4-2 Contact Discharge ESD Test Model

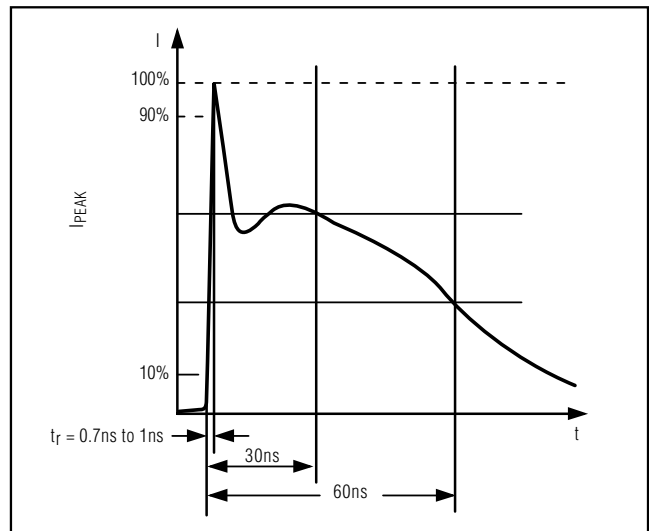

Figure 6. IEC 61000-4-2 ESD Test Model Current Waveform

# Industry-Standard High-Speed CAN Transceivers with $\pm 80V$ Fault Protection

tance. Place the resistor at RS as close as possible to the MAX13052 to minimize any possible noise coupling at the input.

## **Power Supply and Bypassing**

The MAX13050/MAX13052/MAX13053/MAX13054 require no special layout considerations beyond common practices. Bypass  $V_{CC}$  and  $V_{CC2}$  to GND with a 0.1 $\mu$ F ceramic capacitor mounted close to the IC with short lead lengths and wide trace widths.

## **ESD Protection**

ESD-protection structures are incorporated on CANH and CANL to protect against ESD encountered during handling and assembly. CANH and CANL inputs have extra protection to protect against static electricity found in normal operation. Maxim's engineers have developed state-of-the-art structures to protect these pins against  $\pm 8kV$  ESD Contact Discharge without damage. After an ESD event, the MAX13050/MAX13052/MAX13053/

MAX13054 continue working without latchup. ESD protection can be tested in several ways. The CANH and CANL inputs are characterized for protection to  $\pm 8kV$  using the IEC 61000-4-2 Contact Discharge Method per IBEE Test facility.

## **ESD Test Conditions**

ESD performance depends on a number of conditions. Contact Maxim for a reliability report that documents test setup, methodology, and results.

## **Human Body Model**

Figure 5 shows the IEC 61000-4-2 Contact Discharge Model, and Figure 6 shows the current waveform it generates when discharged into a low impedance. This model consists of a 100pF capacitor charged to the ESD voltage of interest, which is then discharged into the device through a 1.5k $\Omega$  resistor.

MAX13050/MAX13052/MAX13053/MAX13054

# Industry-Standard High-Speed CAN Transceivers with $\pm 80V$ Fault Protection

## Functional Diagrams

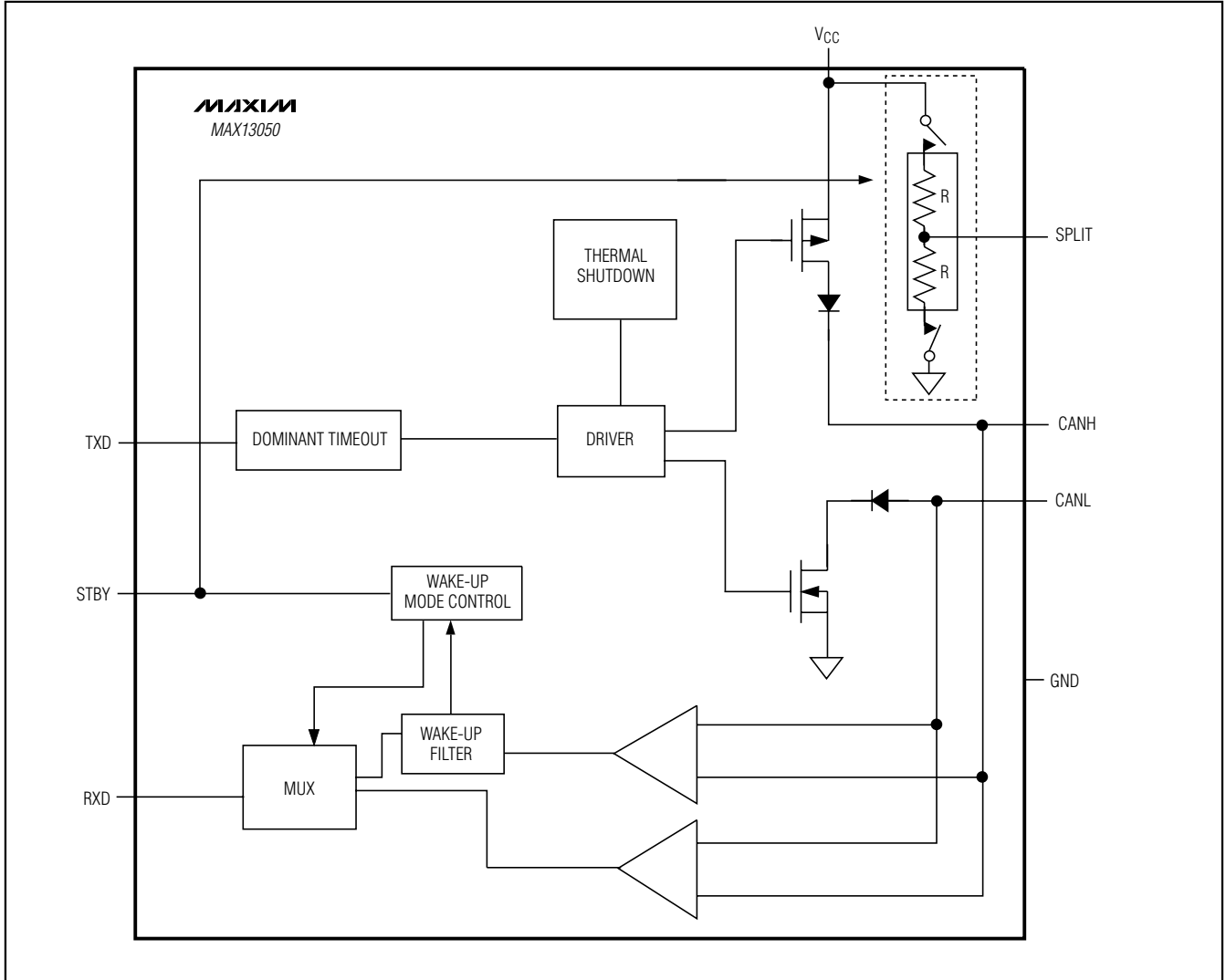

# Industry-Standard High-Speed CAN Transceivers with $\pm 80V$ Fault Protection

## Functional Diagrams (continued)

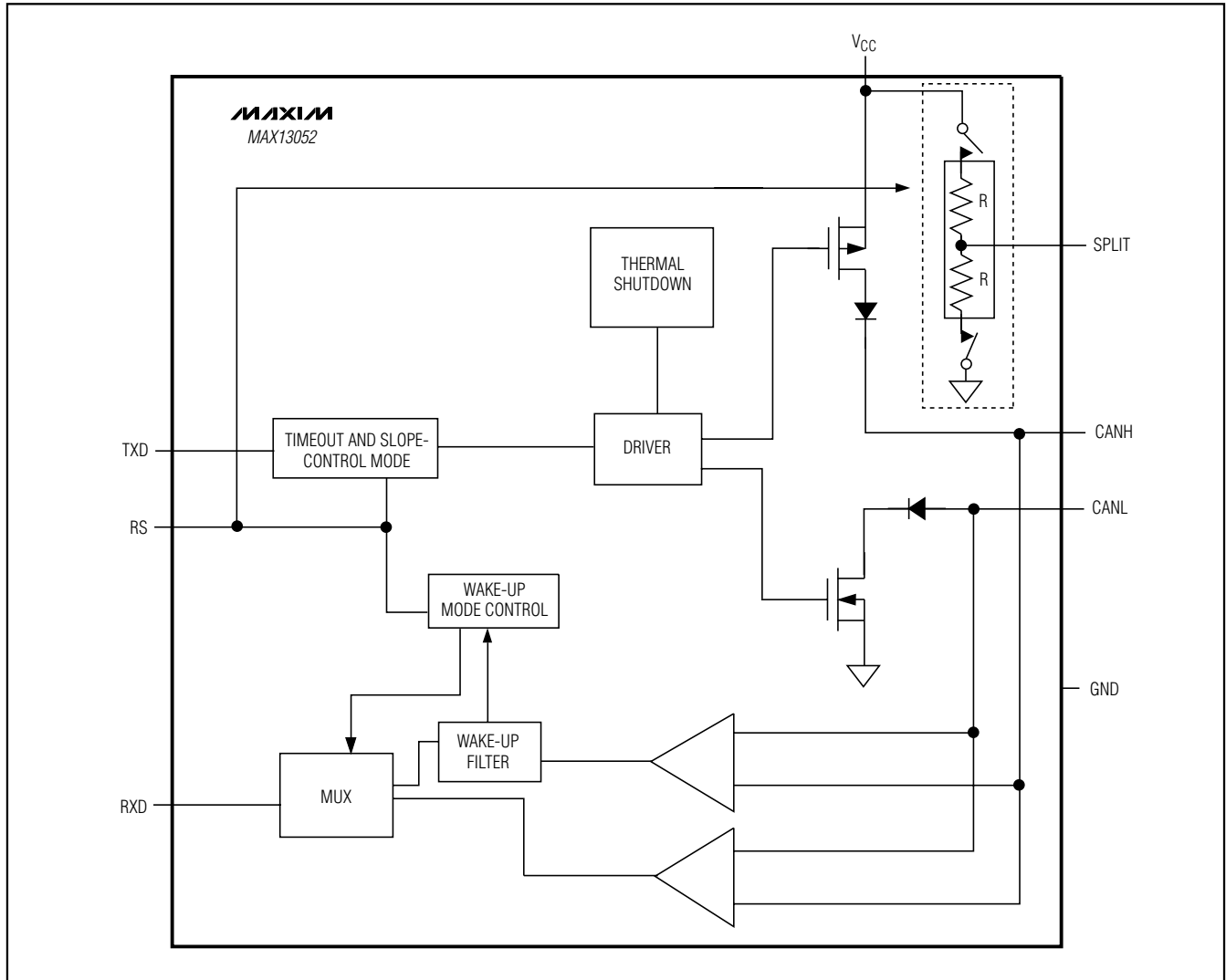

MAX13050/MAX13052/MAX13053/MAX13054

# Industry-Standard High-Speed CAN Transceivers with $\pm 80V$ Fault Protection

## Functional Diagrams (continued)

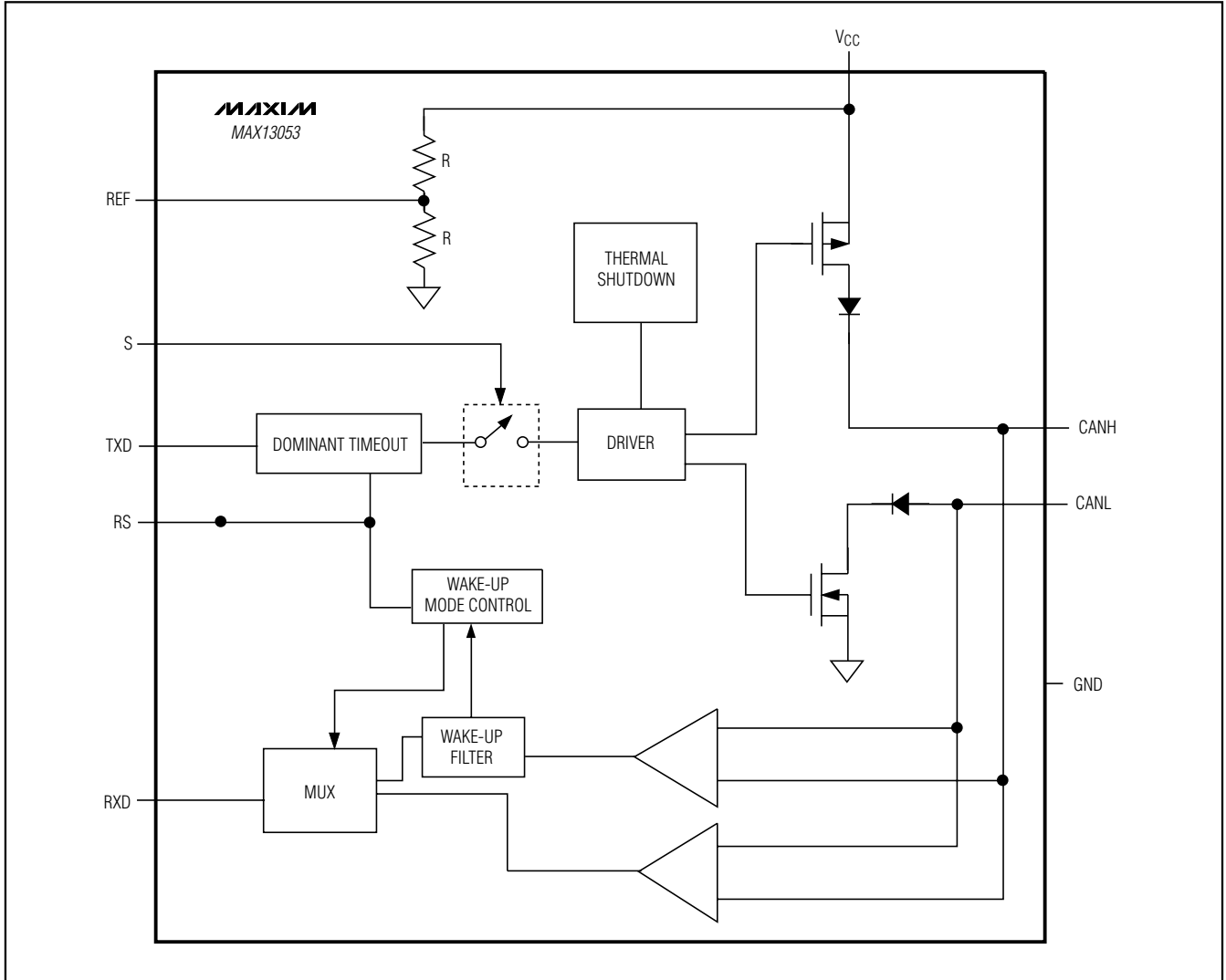



# Industry-Standard High-Speed CAN Transceivers with $\pm 80V$ Fault Protection

## Functional Diagrams (continued)

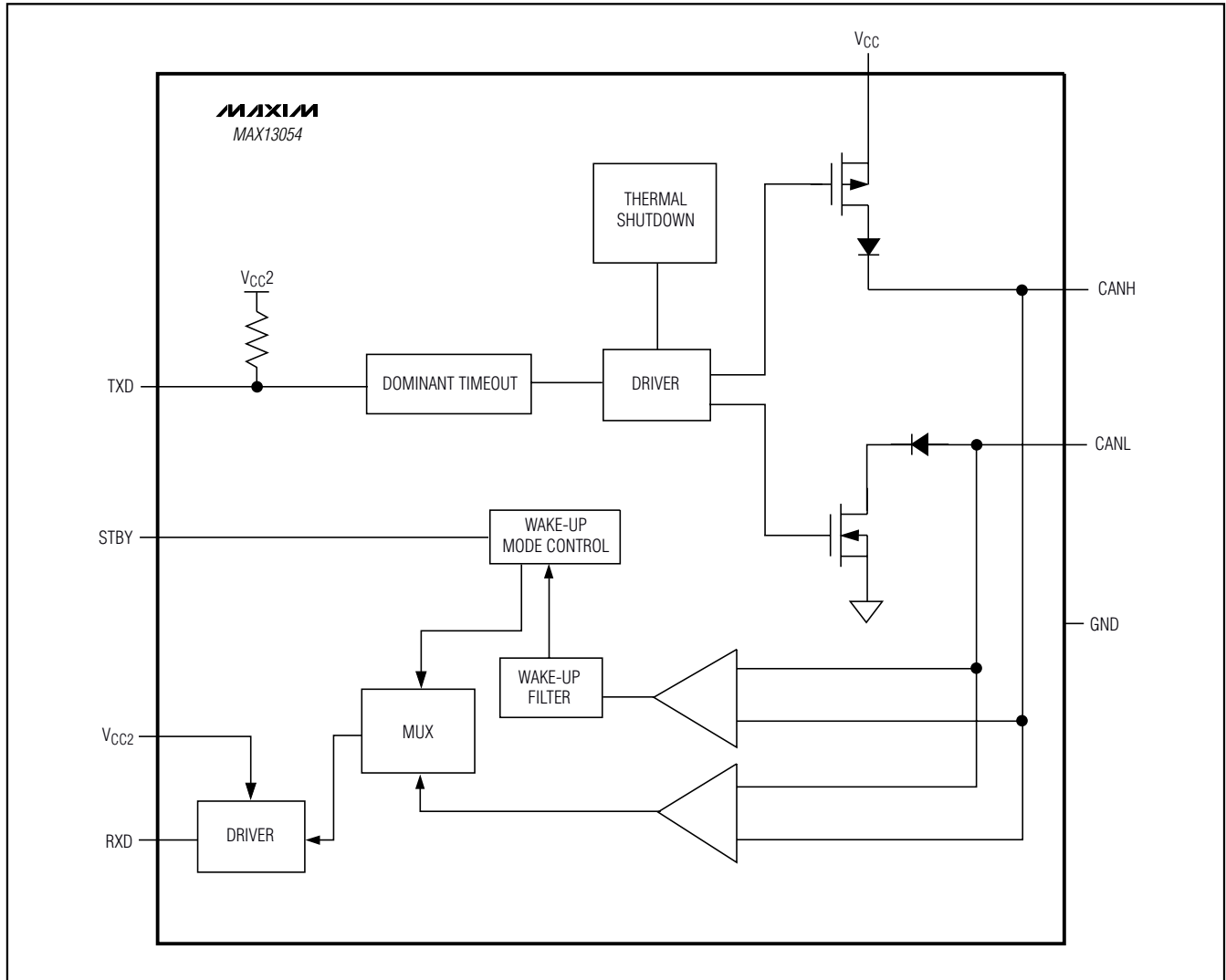

MAX13050/MAX13052/MAX13053/MAX13054

# Industry-Standard High-Speed CAN Transceivers with $\pm 80V$ Fault Protection

## Typical Operating Circuits

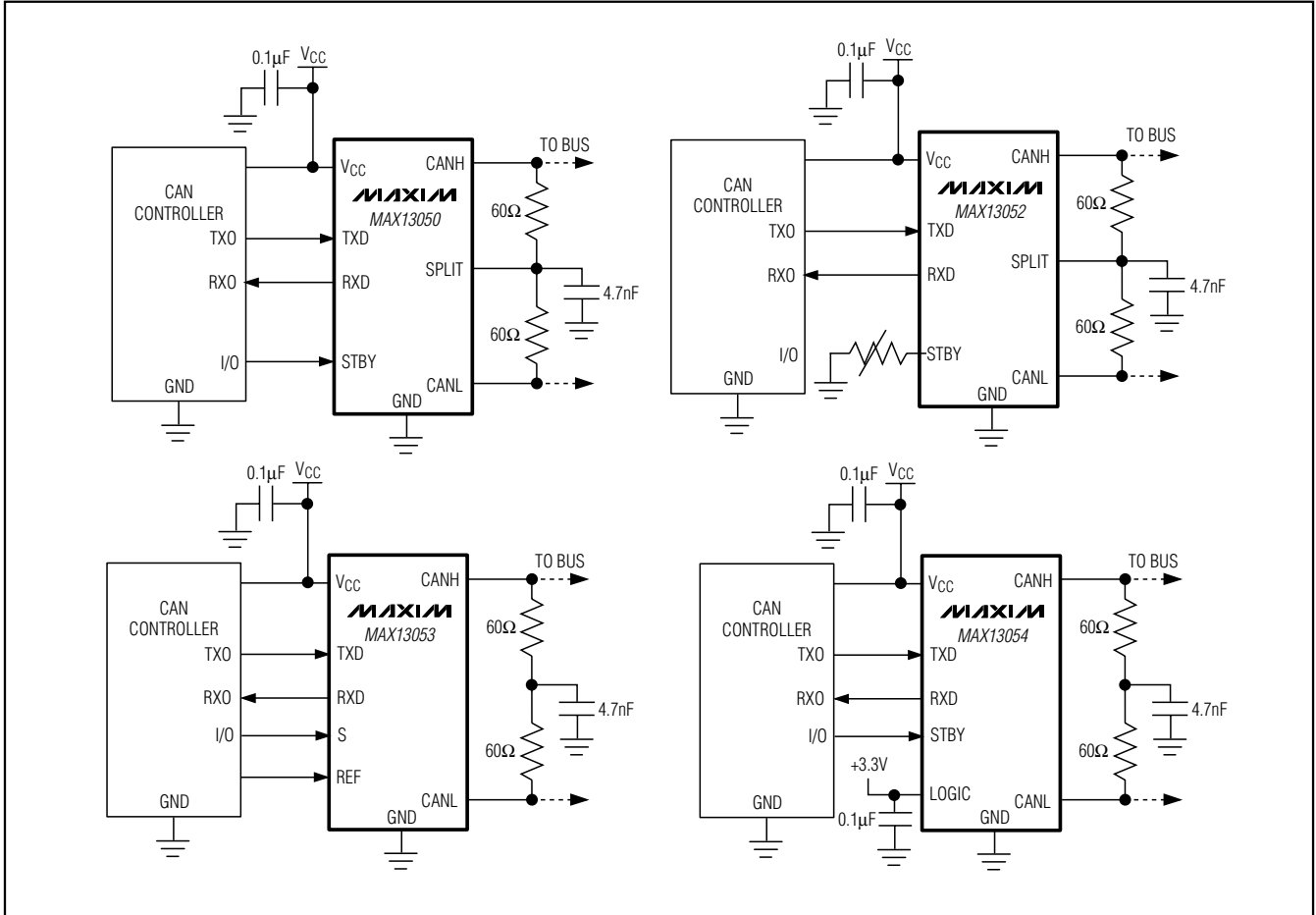

# Industry-Standard High-Speed CAN Transceivers with $\pm 80V$ Fault Protection

## Pin Configurations

MAX13050/MAX13052/MAX13053/MAX13054

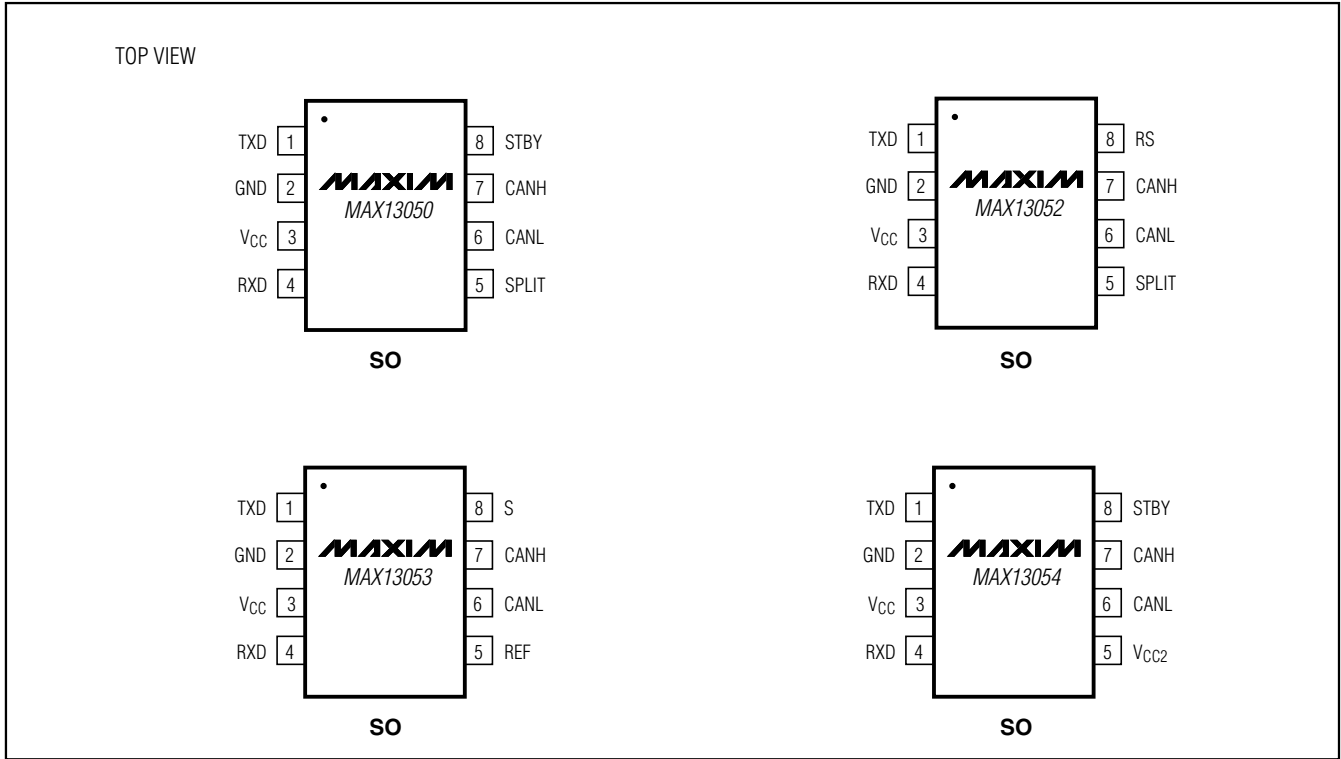

## Chip Information

TRANSISTOR COUNT: 1400

PROCESS: BiCMOS

# Industry-Standard High-Speed CAN Transceivers with $\pm 80V$ Fault Protection

## Package Information

(The package drawing(s) in this data sheet may not reflect the most current specifications. For the latest package outline information, go to [www.maxim-ic.com/packages](http://www.maxim-ic.com/packages).)

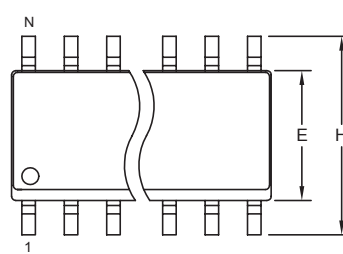

TOP VIEW

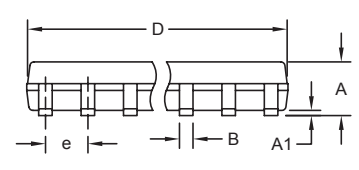

FRONT VIEW

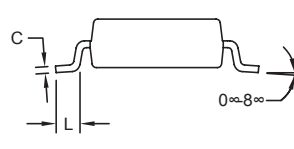

SIDE VIEW

**NOTES:**

1. D&E DO NOT INCLUDE MOLD FLASH.
2. MOLD FLASH OR PROTRUSIONS NOT TO EXCEED 0.15mm (.006").
3. LEADS TO BE COPLANAR WITHIN 0.10mm (.004").
4. CONTROLLING DIMENSION: MILLIMETERS.
5. MEETS JEDEC MS012.
6. N = NUMBER OF PINS.

DIM	INCHES		MILLIMETERS	
	MIN	MAX	MIN	MAX
A	0.053	0.069	1.35	1.75
A1	0.004	0.010	0.10	0.25
B	0.014	0.019	0.35	0.49
C	0.007	0.010	0.19	0.25
e	0.050 BSC		1.27 BSC	
E	0.150	0.157	3.80	4.00
H	0.228	0.244	5.80	6.20
L	0.016	0.050	0.40	1.27

VARIATIONS:

DIM	INCHES		MILLIMETERS		N	MS012
	MIN	MAX	MIN	MAX		
D	0.189	0.197	4.80	5.00	8	AA
D	0.337	0.344	8.55	8.75	14	AB
D	0.386	0.394	9.80	10.00	16	AC

**DALLAS SEMICONDUCTOR** **MAXIM**

PROPRIETARY INFORMATION

TITLE:

PACKAGE OUTLINE, .150" SOIC

APPROVAL	DOCUMENT CONTROL NO.	REV.
	21-0041	B 1/1

SOICN EPS

Maxim cannot assume responsibility for use of any circuitry other than circuitry entirely embodied in a Maxim product. No circuit patent licenses are implied. Maxim reserves the right to change the circuitry and specifications without notice at any time.

20 **Maxim Integrated Products, 120 San Gabriel Drive, Sunnyvale, CA 94086 408-737-7600**

© 2005 Maxim Integrated Products Printed USA **MAXIM** is a registered trademark of Maxim Integrated Products, Inc.