

AS1154 Dual LVDS Driver

1 General Description

The AS1154 is a dual Flow-Through LVDS (Low-Voltage Differential Signaling) Line Driver which accepts and converts LVTTTL/LVCMOS input levels into LVDS output signals. The device is perfect for low-power low-noise applications requiring high signaling rates and reduced EMI emissions.

The device is guaranteed to transmit data at speeds up to 800Mbps (400MHz) over controlled impedance media of approximately 100Ω. Supported transmission media are PCB traces, backplanes, and cables.

Outputs conform to the *ANSI TIA/EIA-644 LVDS* standards. Flow-through pinout simplifies PC board layout and reduces crosstalk by separating the LVTTTL/LVCMOS inputs and LVDS outputs.

The AS1154 operates from a single +3.3V supply and is specified for operation from -40°C to +85°C.

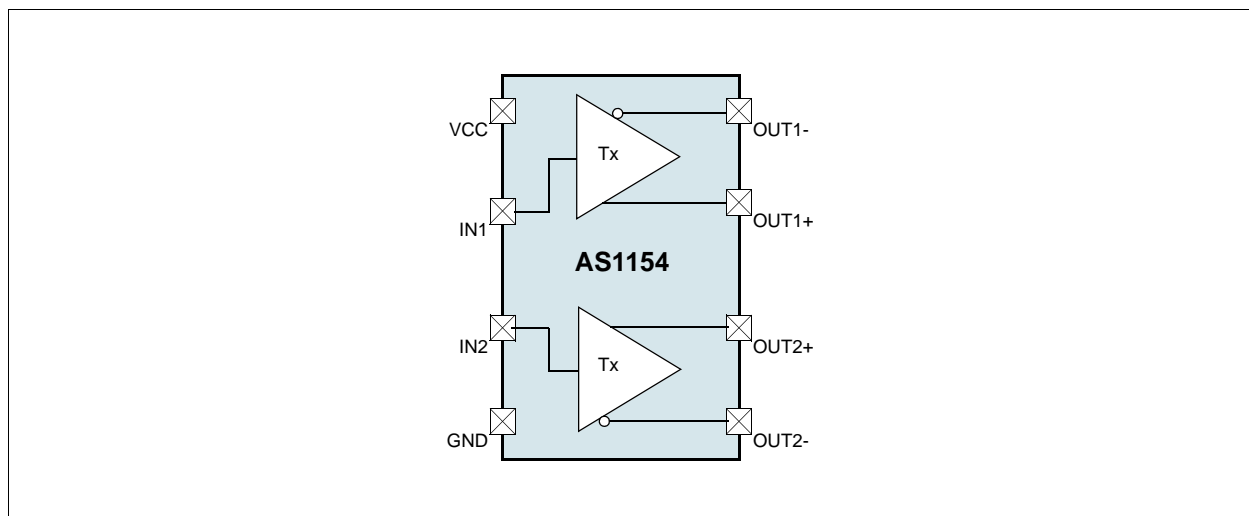
2 Key Features

- Flow-Through Pinout
- Guaranteed 800Mbps Data Rate
- 250ps Pulse Skew (Max)
- Conforms to *ANSI TIA/EIA-644 LVDS* Standards
- Single +3.3V Supply
- Operating Temperature Range: -40°C to +85°C
- 8-Pin SOIC Package

3 Applications

Digital Copiers, Laser Printers, Cellular Phone Base Stations, Add/Drop Muxes, Digital Cross-Connects, DSLAMs, Network Switches/Routers, Backplane Interconnect, Clock Distribution Computers, Intelligent Instruments, Controllers, Critical Microprocessors and Microcontrollers, Power Monitoring, and Portable/Battery-Powered Equipment.

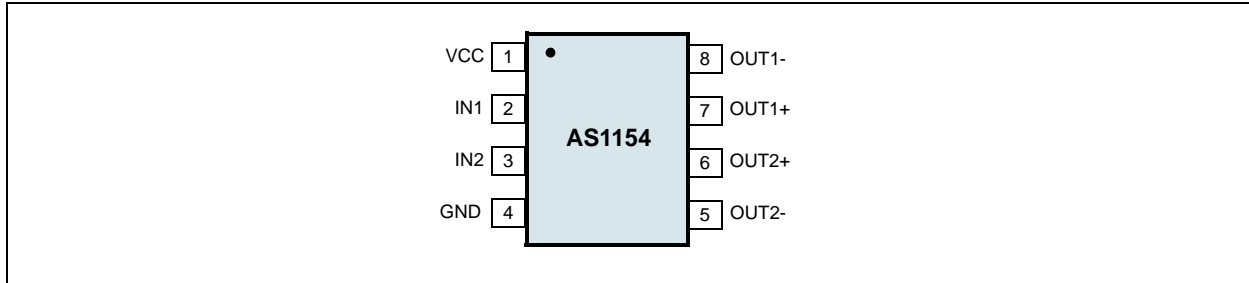
Figure 1. AS1154 - Block Diagram



4 Pinout

Pin Assignments

Figure 2. Pin Assignments (Top View)



Pin Descriptions

Table 1. Pin Descriptions

Pin Number	Pin Name	Description
1	VCC	Power Supply Input. Bypass Vcc to GND with 0.1 μ F and 0.001 μ F ceramic capacitors.
2	IN1	LVTTL/LVCMOS Driver Input
3	IN2	LVTTL/LVCMOS Driver Input
4	GND	Ground
5	OUT2-	Inverting LVDS Driver Output
6	OUT2+	Noninverting LVDS Driver Output
7	OUT1+	Noninverting LVDS Driver Output
8	OUT1-	Inverting LVDS Driver Output

5 Absolute Maximum Ratings

Stresses beyond those listed in Table 2 may cause permanent damage to the device. These are stress ratings only, and functional operation of the device at these or any other conditions beyond those indicated in the operational sections of the specifications is not implied. Exposure to absolute maximum rating conditions for extended periods may affect device reliability.

Table 2. Absolute Maximum Ratings

Parameter	Min	Max	Units	Comments
Electrical Parameters				
VCC to GND	-0.3	5.0	V	
INx to GND	-0.3	V _{CC} + 0.3	V	
OUTx+, OUTx- to GND	-0.3	5.0	V	
Short Circuit Duration (OUTx+, OUTx-)	Continuous			
Electrostatic Discharge				
Electrostatic Discharge HBM	+/- 4		kV	Norm: MIL 883 E method 3015, INx, OUTx+, OUTx-
Continous Power Dissipation (T_A = +70°C)				
Continous Power Dissipation		755	mW	P _{T1} for 8-pin SOIC Package
Continous Power Dissipation Derating Factor		9.4	mW / °C	P _{DERATE} ²
Temperature Ranges and Storage Conditions				
Junction Temperature		+150	°C	
Storage Temperature Range	-55	+125	°C	
Package Body Temperature		+260	°C	The reflow peak soldering temperature (body temperature) specified is in accordance with <i>IPC/ JEDEC J-STD-020*Moisture/Reflow Sensitivity Classification for Non-Hermetic Solid State Surface Mount Devices*</i> . The lead finish for Pb-free leaded packages is matte tin (100% Sn).
Humidity non-condensing	5	85	%	
Moisture Sensitive Level	1			Represents a max. floor life time of unlimited

1. Depending on actual PCB layout and PCB used.
2. P_{DERATE} derating factor changes the total continuous power dissipation (P_T) if the ambient temperature is not 70°C. Therefore for e.g. T_A=85°C calculate P_T at 85°C = P_T - P_{DERATE} x (85°C - 70°C)

6 Electrical Characteristics

DC Electrical Characteristics

$V_{CC} = +3.0V$ to $+3.6V$, $T_A = -40^{\circ}C$ to $+85^{\circ}C$, $R_L = 100\Omega \pm 1\%$, (Typical values are at $V_{CC} = +3.3V$, $T_A = +25^{\circ}C$) unless otherwise specified,¹

Table 3. DC Electrical Characteristics

Parameter	Symbol	Conditions	Min	Typ	Max	Unit
Operating Temperature Range	T_A		-40		+85	$^{\circ}C$
LVDS Output (OUT_{x+}, OUT_{x-})						
Differential Output Voltage	V_{OD}	Figure 21 on page 12	250	355	450	mV
Change in Magnitude of V_{OD} Between Complementary Output States	ΔV_{OD}	Figure 21 on page 12		1	35	mV
Offset Voltage	V_{OS}	Figure 21 on page 12	1.125	1.25	1.375	V
Change in Magnitude of V_{OS} Between Complementary Output States	ΔV_{OS}	Figure 21 on page 12		4	25	mV
Output High Voltage	V_{OH}				1.6	V
Output Low Voltage	V_{OL}		0.90			V
Differential Output Short-Circuit Current ²	I_{OSD}	$V_{OD} = 0V$			-9	mA
Output Short-Circuit Current	I_{OS}	OUT _{x+} = 0V at IN _x = V _{CC} or OUT _{x-} = 0V at IN _x = 0V		-3.7	-9	mA
Power-Off Output Current	I_{OFF}	$V_{CC} = 0V$ or open, OUT _{x+} = 0V or 3.6V OUT _{x-} = 0V or 3.6V, $R_L = \infty$	-20		20	μA
Inputs (IN_x)						
High-Level Input Voltage	V_{IH}		2.0		V_{CC}	V
Low-Level Input Voltage	V_{IL}		GND		0.8	V
Input Current	I_{IN}	IN _x = 0V or V _{CC}	-20		20	μA
Supply Current						
No-Load Supply Current	I_{CC}	$R_L = \infty$, IN _x = V _{CC} or 0V for all channels		2	3.5	mA
Loaded Supply Current	I_{CCL}	$R_L = 100\Omega$, IN _x = V _{CC} or 0V for all channels		5.5	7.5	mA
		$R_L = 100\Omega$, IN _x = V _{CC} or 0V for all channels		8.5	12	mA

Notes:

1. Currents into the device are positive, and current out of the device is negative. All voltages are referenced to ground except V_{OD} .
2. Guaranteed by correlation data.
3. All limits are guaranteed. The parameters with min and max values are guaranteed with production tests or SQC (Statistical Quality Control) methods.

Switching Characteristics

$V_{CC} = +3.0V$ to $+3.6V$, $R_L = 100\Omega \pm 1\%$, $C_L = 2.5pF$ (differential), $T_A = -40^\circ C$ to $+85^\circ C$, (Typical values are at $V_{CC} = +3.3V$, $T_A = +25^\circ C$) unless otherwise specified, 1, 2, 3, 10

Table 4. Switching Characteristics

Parameter	Symbol	Conditions	Min	Typ	Max	Unit
Differential Propagation Delay, High-to-Low	tPHLD	Figure 20 on page 11 and Figure 21 on page 12	1.1	1.268	1.5	ns
Differential Propagation Delay, Low-to-High	tPLHD	Figure 20 on page 11 and Figure 21 on page 12	1.1	1.267	1.5	ns
Differential Pulse Skew ⁴	tSKD1	Figure 20 on page 11 and Figure 21 on page 12		90	200	ps
Differential Channel-to-Channel Skew ⁵	tSKD2	Figure 20 on page 11 and Figure 21 on page 12		110	250	ps
Differential Part-to-Part Skew ⁶	tSKD3	Figure 20 on page 11 and Figure 21 on page 12			750	ps
Differential Part-to-Part Skew ⁷	tSKD4	Figure 20 on page 11 and Figure 21 on page 12			900	ps
Rise Time	tTLH	Figure 20 on page 11 and Figure 21 on page 12	200	356	800	ps
Fall Time	tTHL	Figure 20 on page 11 and Figure 21 on page 12	200	352	800	ps
Maximum Operating Frequency ^{8, 9}	fMAX		400			MHz

Notes:

- Parameters are guaranteed by design and characterization.
- C_L includes probe and jig capacitance.
- Signal generator conditions for dynamic tests: $V_{OL} = 0$, $V_{OH} = 2.4V$, $f = 100MHz$, 50% duty cycle, $R_O = 50\Omega$, $t_R \leq 1ns$, $t_F \leq 1ns$ (0 to 100%).
- tSKD1 is the magnitude difference of differential propagation delay. $tSKD1 = |tPHLD - tPLHD|$.
- tSKD2 is the magnitude difference of tPHLD or tPLHD of one channel to the tPHLD or tPLHD of another channel on the same device.
- tSKD3 is the magnitude difference of any differential propagation delays between devices at the same V_{CC} and within $5^\circ C$ of each other.
- tSKD4 is the magnitude difference of any differential propagation delays between devices operating over the rated supply and temperature ranges.
- fMAX signal generator conditions: $V_{OL} = 0$, $V_{OH} = 2.4V$, 50% duty cycle, $R_O = 50\Omega$, $t_R \leq 1ns$, $t_F \leq 1ns$ (0 to 100%).
- Transmitter output criteria: duty cycle = 45 to 55%, $V_{OD} \geq 250mV$.
- For optimum performance matched circuits should be used.

7 Typical Operating Characteristics

$V_{CC} = +3.3V$, $C_{LOAD} = 2.5pF$ (differential), $Freq = 20MHz$, $T_{amb} = +25^{\circ}C$, unless otherwise specified;

Figure 3. Transition Time vs. V_{CC}

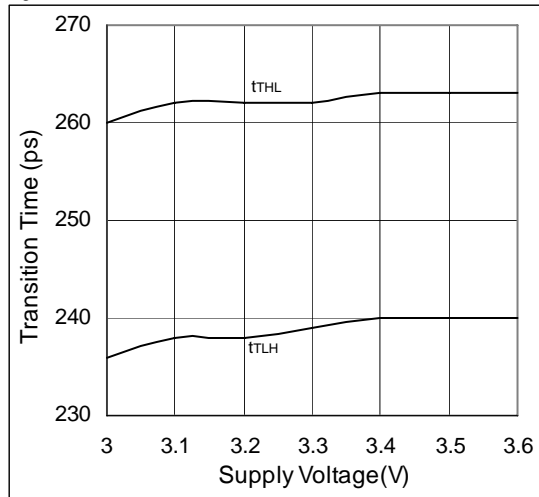


Figure 4. Transition Time vs. Temperature

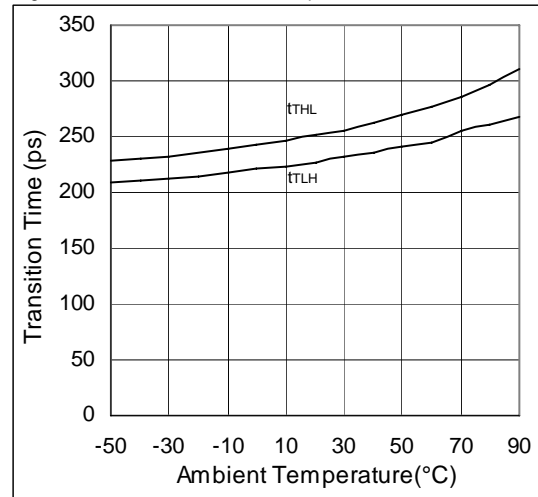


Figure 5. Differential Pulse Skew vs. V_{CC}

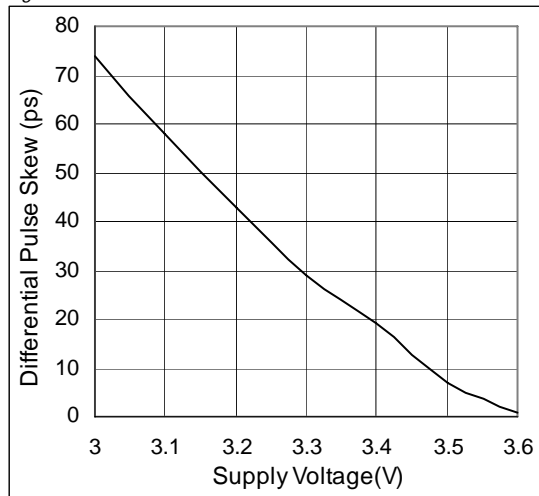


Figure 6. Pulse Skew vs. Temperature

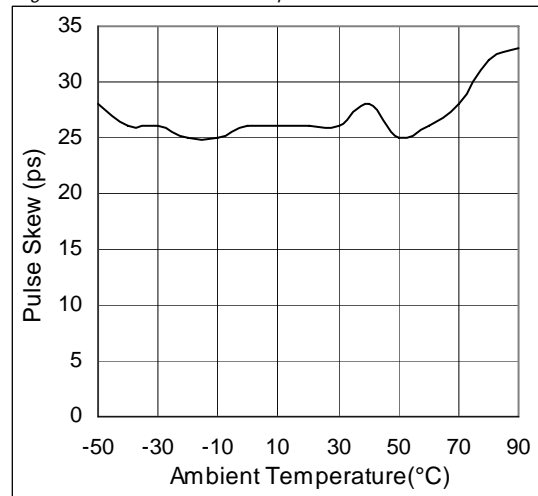


Figure 7. Differential Propagation Delay vs. V_{CC} ;

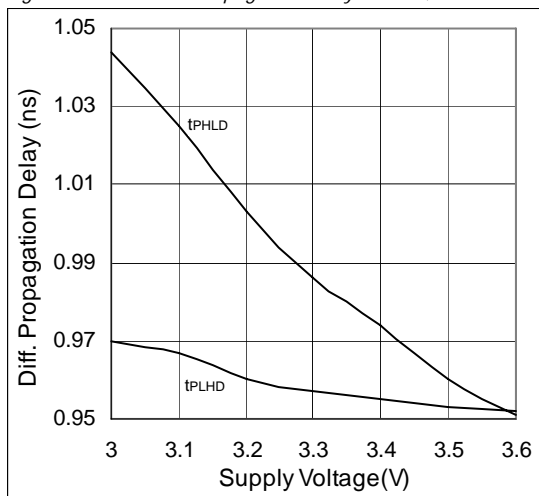


Figure 8. Differential Propagation Delay vs. Temp.

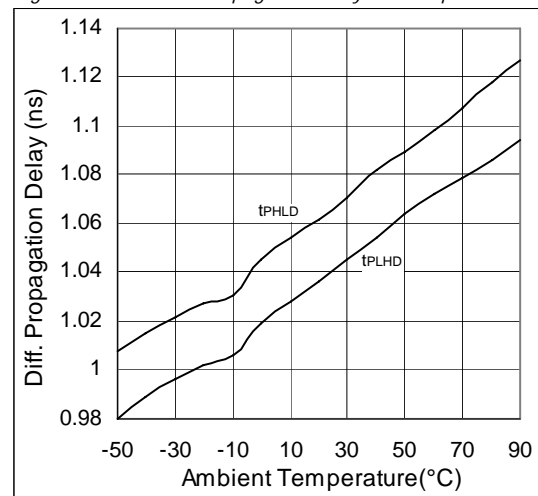


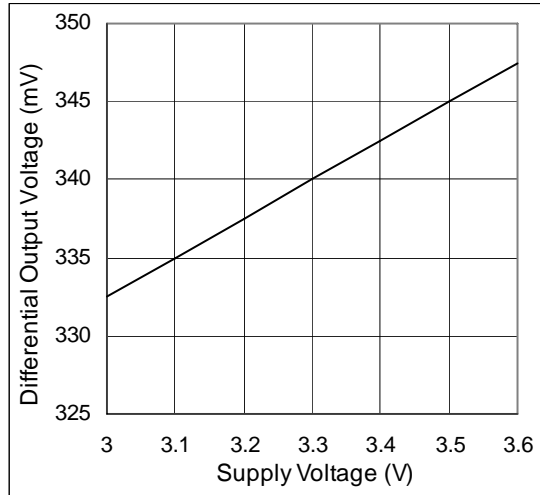
Figure 9. Differential Output Voltage vs. V_{CC} 

Figure 10. Differential Output Voltage vs. Frequency

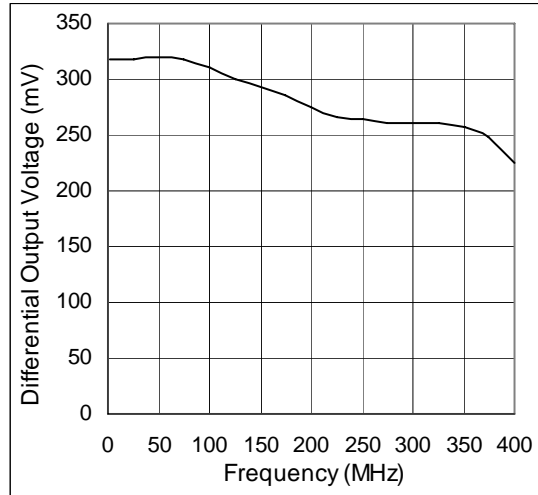
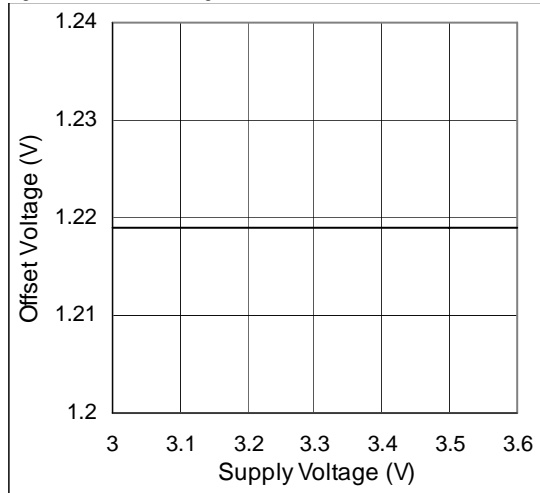
Figure 11. Offset Voltage vs. V_{CC} 

Figure 12. Offset Voltage vs. Frequency

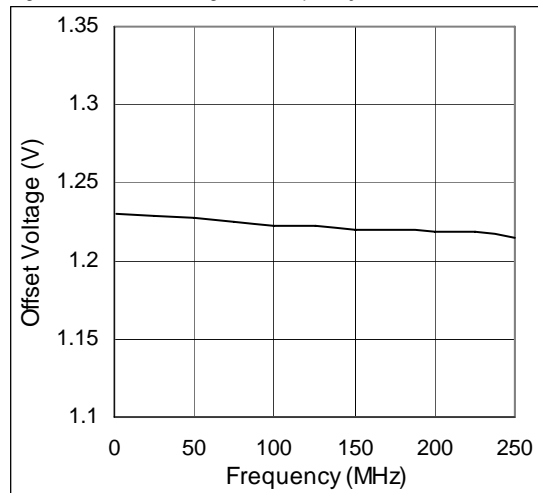
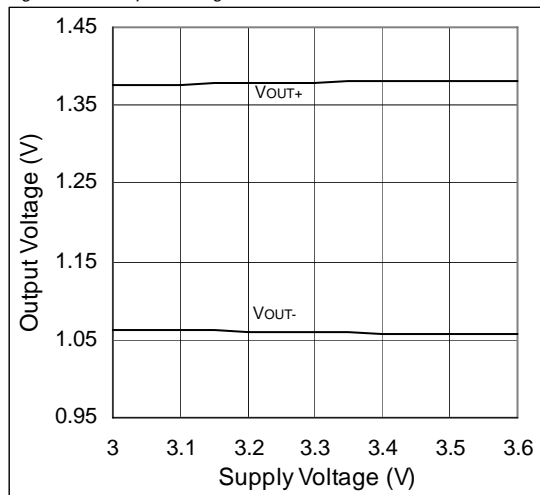
Figure 13. Output Voltage vs. V_{CC} ;

Figure 14. Output Voltage vs. Load Resistance;

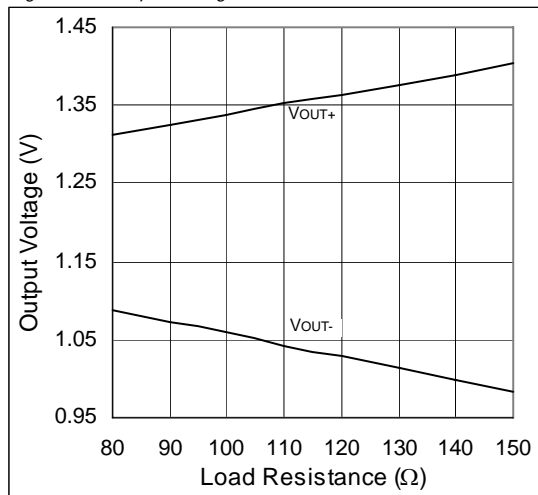
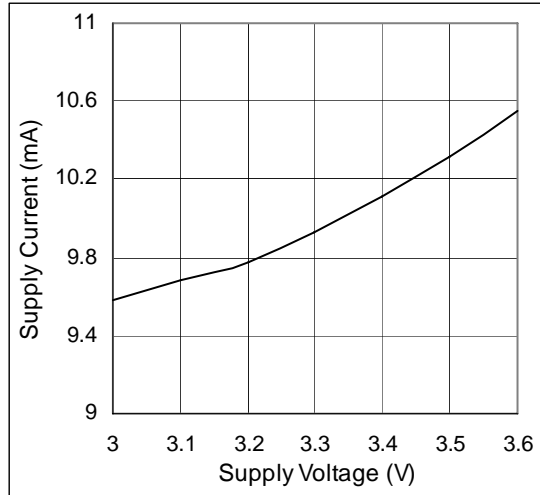
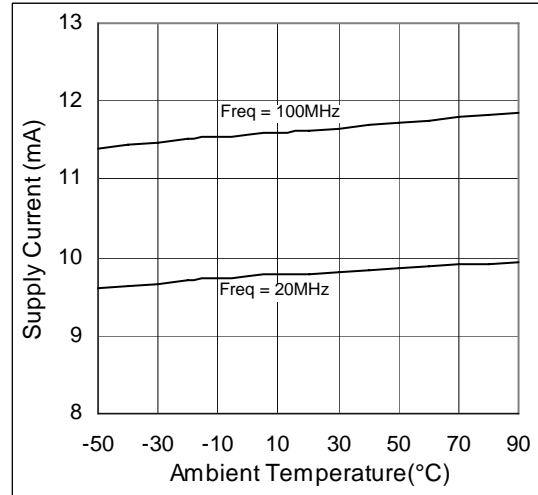
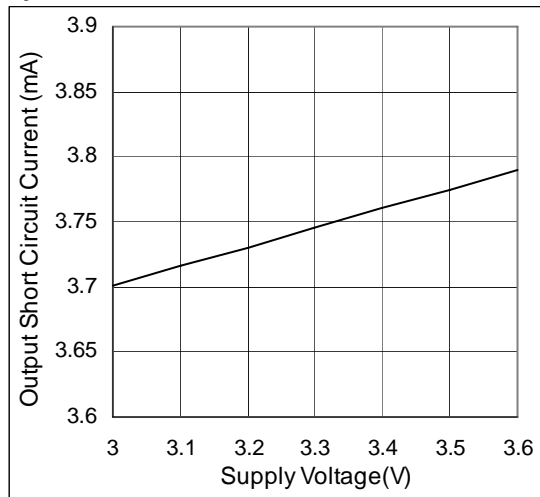
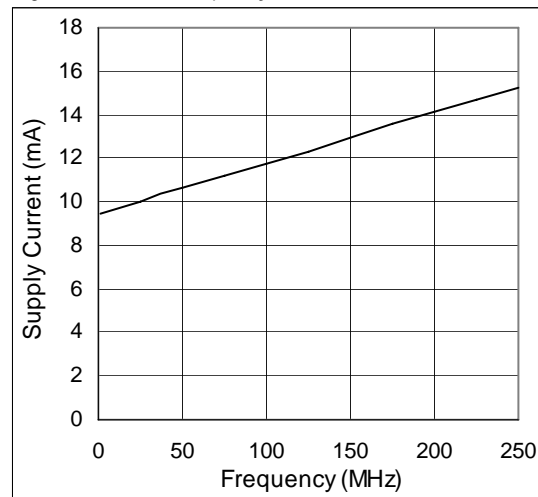


Figure 15. I_{CC} vs. V_{CC} Figure 16. I_{CC} vs. Temperature;Figure 17. Short Circuit Current vs. V_{CC} Figure 18. I_{CC} vs. Frequency

8 Detailed Description

LVDS Interface

The LVDS interface standard is a signaling method intended for point-to-point communication over a controlled-impedance medium as defined by the *ANSI/TIA/EIA-644* and *IEEE 1596.3* standards. The LVDS standard uses a lower voltage swing than other common communication standards, achieving higher data rates with reduced power consumption while reducing EMI emissions and system susceptibility to noise.

The AS1154 is an 800Mbps dual differential LVDS driver that is designed for high-speed, point-to-point, low-power applications. This device accepts LVTTTL/LVCMOS input levels and translates them to LVDS output signals.

The AS1154 generates a 2.5mA to 4.5mA output current using a current-steering configuration. This current steering approach induces less ground bounce and no shoot-through current, enhancing noise margin and system speed performance. The driver outputs are short-circuit current limited, and enter a high-impedance state when the device is not powered or is disabled.

The current-steering architecture of the AS1154 requires a resistive load to terminate the signal and complete the transmission loop. Because the device switches current and not voltage, the actual output voltage swing is determined by the value of the termination resistor at the input of an LVDS receiver (AS1157, AS1158). Logic states are determined by the direction of current flow through the termination resistor.

With a typical 3.7mA output current, the AS1154 produces an output voltage of 370mV when driving a 100Ω load.

Termination

Because the AS1154 is a current-steering device, no output voltage will be generated without a termination resistor. The termination resistors should match the differential impedance of the transmission line. Output voltage levels depend upon the value of the termination resistor.

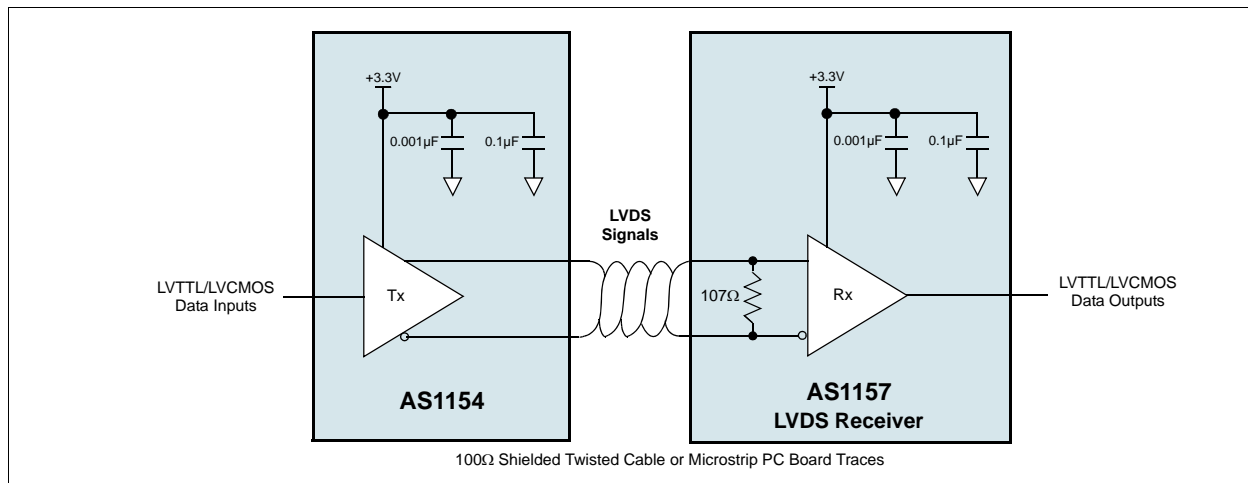
The AS1154 is optimized for point-to-point interface with 100Ω termination resistors at the receiver inputs. Termination resistance values may range between 90 and 132Ω, depending on the characteristic impedance of the transmission medium.

9 Applications

Table 5. Function Table

Input	Output	
	OUT _{x+}	OUT _{x-}
L	L	H
H	H	L
0.8V < V _{INx} < 2.0V	Undetermined	Undetermined

Figure 19. Typical Application Circuit



Power-Supply Bypassing

To bypass V_{CC}, use high-frequency surface-mount ceramic 0.1µF and 0.001µF capacitors in parallel as close to the device as possible, with the smaller valued capacitor closest to pin V_{CC}.

Differential Traces

Input trace characteristics can adversely affect the performance of the AS1154.

- Use controlled-impedance PC board traces to match the cable characteristic impedance. The termination resistor is also matched to this characteristic impedance.
- Eliminate reflections and ensure that noise couples as common mode by running the differential traces near each other.
- Reduce skew by using matched trace lengths. Tight skew control is required to minimize emissions and proper data recovery of the devices.
- Route each channel's differential signals very close to each other for optimal cancellation of their respective external magnetic fields. Use a constant distance between the differential traces to avoid irregularities in differential impedance.
- Avoid 90° turns (use two 45° turns).
- Minimize the number of vias to further prevent impedance irregularities.

Cables and Connectors

Supported transmission media include printed circuit board traces, backplanes, and cables.

- Use cables and connectors with matched differential impedance (typically 100Ω) to minimize impedance mismatches.
- Balanced cables such as twisted pair offer superior signal quality and tend to generate less EMI due to magnetic field canceling effects. Balanced cables pick up noise as common mode, which is rejected by the LVDS receiver.
- Avoid the use of unbalanced cables such as ribbon cable or simple coaxial cable.

Board Layout

The device should be placed as close to the interface connector as possible to minimize LVDS trace length.

- Keep the LVDS and any other digital signals separated from each other to reduce crosstalk.
- Use a four-layer PC board that provides separate power, ground, LVDS signals, and input signals.
- Isolate the input LVDS signals from each other and the output LVCMOS/LVTTL signals from each other to prevent coupling.
- Separate the input LVDS signals from the output signals planes with the power and ground planes for best results.

Figure 20. Driver Propagation Delay and Transition Time Waveforms

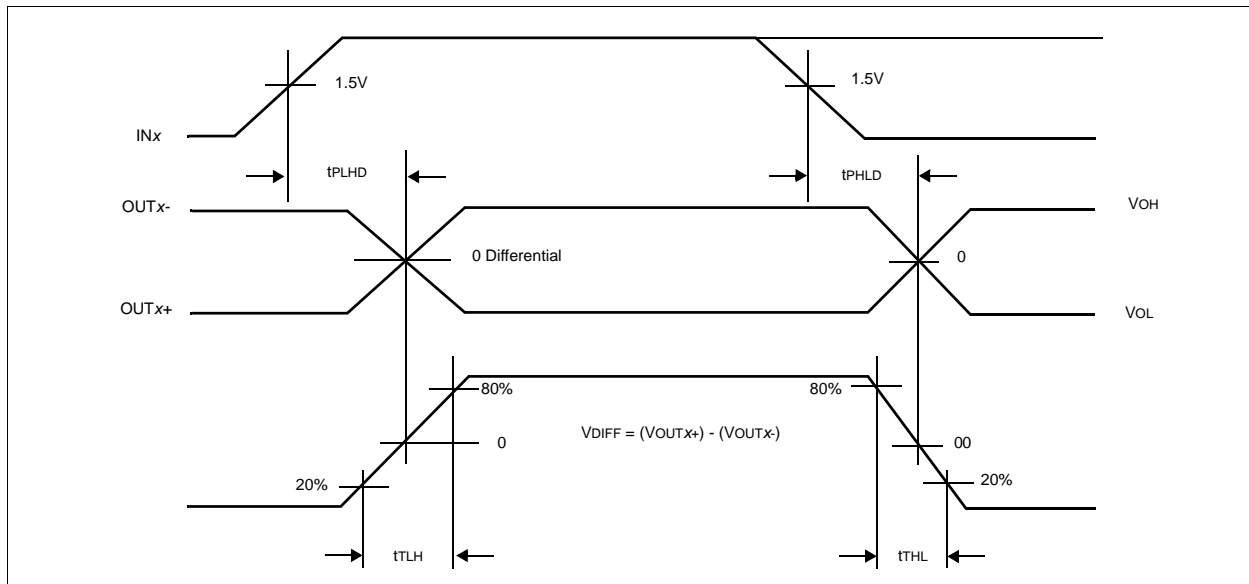


Figure 21. Driver Propagation Delay and Transition Time Test Circuit

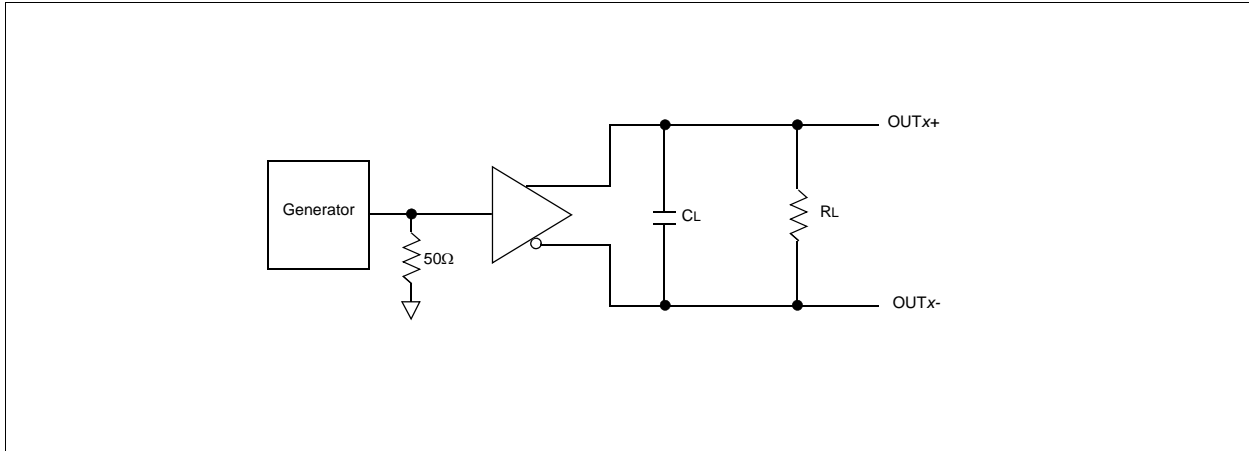
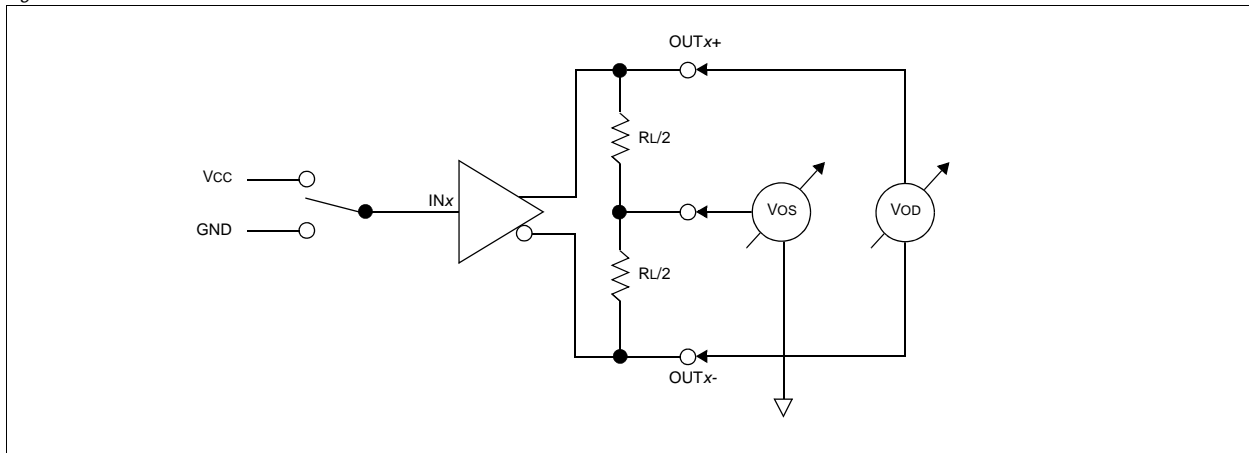


Figure 22. Driver V_{od} and V_{os} Test Circuit



10 Package Drawings and Markings

Figure 23. 8-pin SOIC Marking

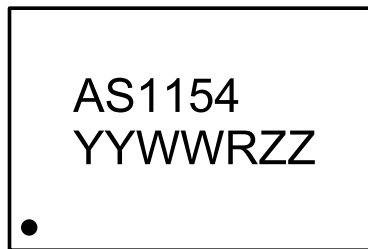
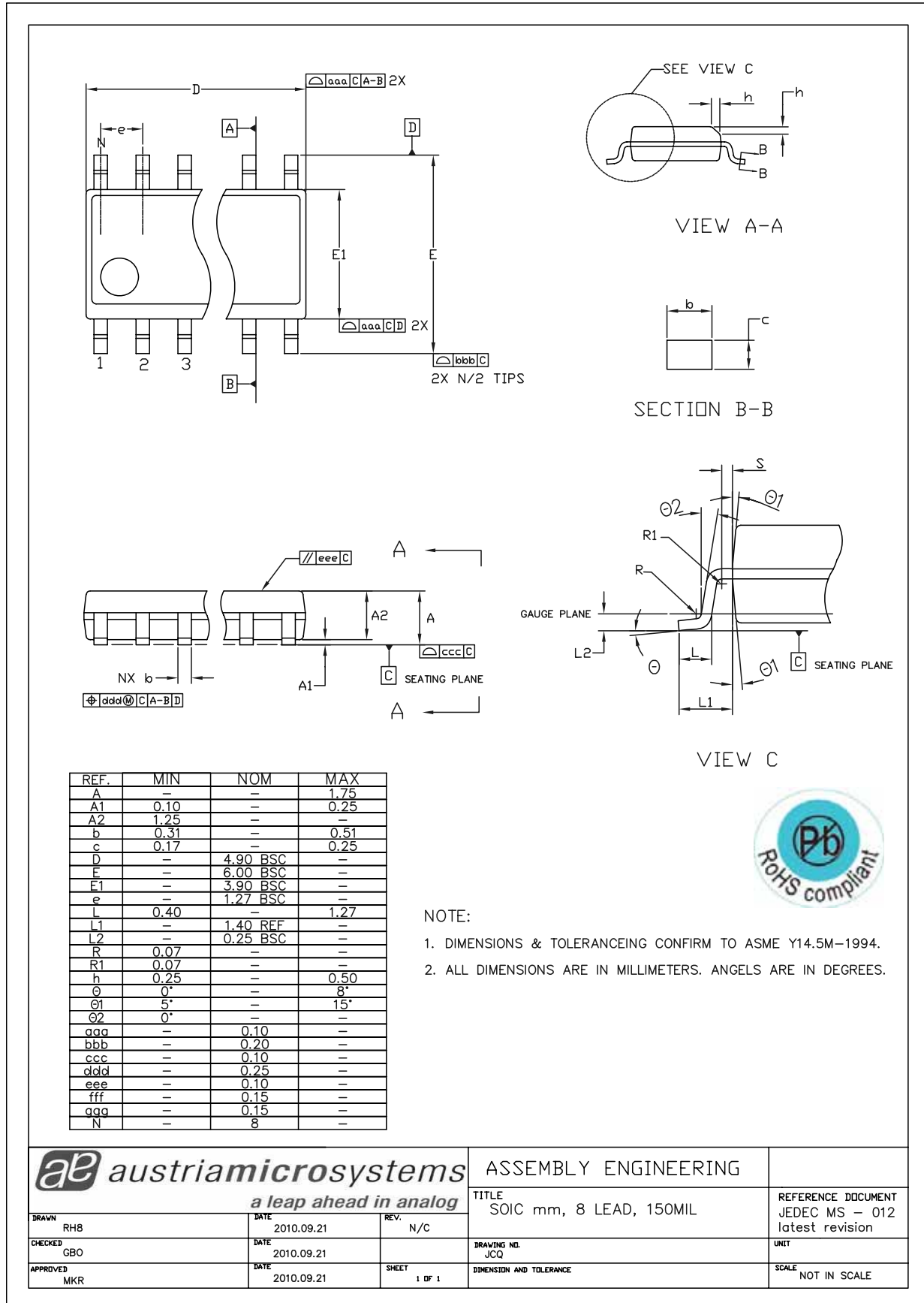


Table 6. Packaging Code AYWWRZZ

YY	WW	R	ZZ
last two digits of the current year	manufacturing week	plant identifier	free choice / traceability code

Figure 24. 8-pin SOIC Package



11 Ordering Information

The devices are available as the standard products shown in Table 7.

Table 7. Ordering Information

Ordering Code	Marking	Description	Delivery Form	Package
AS1154-BSOU	AS1154	Dual LVDS Driver	Tubes	8-pin SOIC
AS1154-BSOT	AS1154	Dual LVDS Driver	Tape and Reel	8-pin SOIC

Note: All products are RoHS compliant.

Buy our products or get free samples online at ICdirect: <http://www.austriamicrosystems.com/ICdirect>

Technical Support is found at <http://www.austriamicrosystems.com/Technical-Support>

For further information and requests, please contact us <mailto:sales@austriamicrosystems.com>
or find your local distributor at <http://www.austriamicrosystems.com/distributo>

Copyrights

Copyright © 1997-2010, austriamicrosystems AG, Tobelbaderstrasse 30, 8141 Unterpremstaetten, Austria-Europe. Trademarks Registered ®. All rights reserved. The material herein may not be reproduced, adapted, merged, translated, stored, or used without the prior written consent of the copyright owner.

All products and companies mentioned are trademarks or registered trademarks of their respective companies.

Disclaimer

Devices sold by austriamicrosystems AG are covered by the warranty and patent indemnification provisions appearing in its Term of Sale. austriamicrosystems AG makes no warranty, express, statutory, implied, or by description regarding the information set forth herein or regarding the freedom of the described devices from patent infringement. austriamicrosystems AG reserves the right to change specifications and prices at any time and without notice. Therefore, prior to designing this product into a system, it is necessary to check with austriamicrosystems AG for current information. This product is intended for use in normal commercial applications. Applications requiring extended temperature range, unusual environmental requirements, or high reliability applications, such as military, medical life-support or life-sustaining equipment are specifically not recommended without additional processing by austriamicrosystems AG for each application. For shipments of less than 100 parts the manufacturing flow might show deviations from the standard production flow, such as test flow or test location.

The information furnished here by austriamicrosystems AG is believed to be correct and accurate. However, austriamicrosystems AG shall not be liable to recipient or any third party for any damages, including but not limited to personal injury, property damage, loss of profits, loss of use, interruption of business or indirect, special, incidental or consequential damages, of any kind, in connection with or arising out of the furnishing, performance or use of the technical data herein. No obligation or liability to recipient or any third party shall arise or flow out of austriamicrosystems AG rendering of technical or other services.



Contact Information

Headquarters

austriamicrosystems AG
Tobelbaderstrasse 30
A-8141 Unterpremstaetten, Austria

Tel: +43 (0) 3136 500 0
Fax: +43 (0) 3136 525 01

For Sales Offices, Distributors and Representatives, please visit:

<http://www.austriamicrosystems.com/contact>