

DS9637A

Dual Differential Line Receiver

General Description

The DS9637A is a Schottky dual differential line receiver which has been specifically designed to satisfy the requirements of EIA Standards RS-422 and RS-423. In addition, the DS9637A satisfies the requirements of MIL-STD 188-114 and is compatible with the International Standard CCITT recommendations. The DS9637A is suitable for use as a line receiver in digital data systems, using either single ended or differential, unipolar or bipolar transmission. It requires a single 5V power supply and has Schottky TTL compatible outputs. The DS9637A has an operational input common mode range of $\pm 7V$ either differentially or to ground.

Features

- Dual channel
- Single 5V supply
- Satisfies EIA standards RS-422 and RS423
- Built-in ± 35 mV hysteresis
- High input common mode voltage range
- High input impedance
- TTL compatible outputs
- Schottky technology
- Extended temperature range

Connection Diagram

8-Lead DIP and SO-8 Package

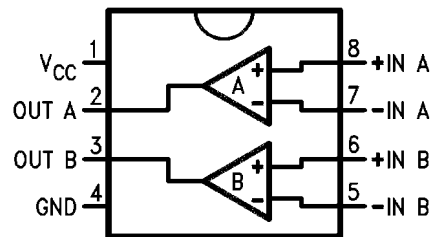

962101

Top View

Order Number DS9637ACM or DS9637ACN
 See NS Package Number M08A or N08E
 For Complete Military Product Specifications,
 refer to the appropriate SMD or MDS.
 Order Number DS9637AMJ/883
 See NS Package Number J08A

Absolute Maximum Ratings (Note 2)

If Military/Aerospace specified devices are required, please contact the National Semiconductor Sales Office/ Distributors for availability and specifications.

Storage Temperature Range	
Ceramic DIP	-65°C to +175°C
Molded DIP	-65°C to +150°C
Lead Temperature	
Ceramic DIP (Soldering, 30 seconds)	300°C
Molded DIP and SO Package (Soldering, 10 seconds)	265°C
Maximum Power Dissipation (Note 1) at 25°C	
Cavity Package	1300 mW
Molded Package	930 mW
SO Package	810 mW
V _{CC} Lead Potential to Ground	-0.5V to 7.0V
Input Potential to Ground	±15V

Differential Input Voltage	±15V
Output Potential to Ground	-0.5V to +5.5V
Output Sink Current	50 mA
ESD Susceptibility, HBM	≥2 kV

Recommended Operating Conditions

	DS9637AM	Min	Max	Units
Supply Voltage (V _{CC})		4.5	5.5	V
Operating Temperature (T _A)		-55	+125	°C
	DS9637AC	Min	Max	Units
Supply Voltage (V _{CC})		4.75	5.25	V
Operating Temperature (T _A)		0	+70	°C

Note 1: Derate cavity package 8.7 mW/°C above 25°C; derate molded DIP package 7.5 mW/°C above 25°C; derate SO package 6.5 mW/°C above 25°C.

Electrical Characteristics (Notes 3, 4)

Over recommended operating temperature and supply voltage ranges, unless otherwise specified

Symbol	Parameter	Conditions	Min	Typ	Max	Units
V _{TH}	Differential Input Threshold Voltage (Note 6)	-7.0V ≤ V _{CM} ≤ +7.0V	-0.2		+0.2	V
V _{TH(R)}	Differential Input Threshold Voltage (Note 7)	-7.0V ≤ V _{CM} ≤ +7.0V	-0.4		+0.4	V
I _I	Input Current (Note 8)	V _I = 10V, 0V ≤ V _{CC} ≤ +5.5V		1.1	3.25	mA
		V _I = -10V, 0V ≤ V _{CC} ≤ +5.5V		-1.6	-3.25	
V _{OL}	Output Voltage LOW	I _{OL} = 20 mA, V _{CC} = Min		0.35	0.5	V
V _{OH}	Output Voltage HIGH	I _{OH} = -1.0 mA, V _{CC} = Min	2.5	3.5		V
I _{OS}	Output Short Circuit Current (Note 5)	V _O = 0V, V _{CC} = Max	-40	-75	-100	mA
I _{CC}	Supply Current	V _{CC} = Max, V _{I+} = 0.5V, V _{I-} = GND		35	50	mA
V _{HYST}	Input Hysteresis	V _{CM} = ±7.0V (See Curves)		70		mV

Note 2: "Absolute Maximum Ratings" are those values beyond which the safety of the device cannot be guaranteed. They are not meant to imply that the devices should be operated at these limits. The tables of "Electrical Characteristics" provide conditions for actual device operation.

Note 3: Unless otherwise specified Min/Max limits apply across the -55°C to +125°C temperature range for DS9637AM and across the 0°C to +70°C range for the DS9637ASC. All typicals are given for V_{CC} = 5V and T_A = 25°C.

Note 4: All currents into the device pins are positive; all currents out of the device pins are negative. All voltages are referenced to ground unless otherwise specified.

Note 5: Only one output at a time should be shorted.

Note 6: V_{DIFF} (Differential Input Voltage) = (V_{I+}) - (V_{I-}). V_{CM} (Common Mode Input Voltage) = V_{I+} or V_{I-}.

Note 7: 500Ω ±1% in series with inputs.

Note 8: The input not under test is tied to ground.

Switching Characteristics

V_{CC} = 5.0V, T_A = 25°C

Symbol	Parameter	Conditions	Min	Typ	Max	Units
t _{PLH}	Propagation Delay Time Low to High	See AC Test Circuit		15	25	ns
t _{PHL}	Propagation Delay Time High to Low	See AC Test Circuit		13	25	ns

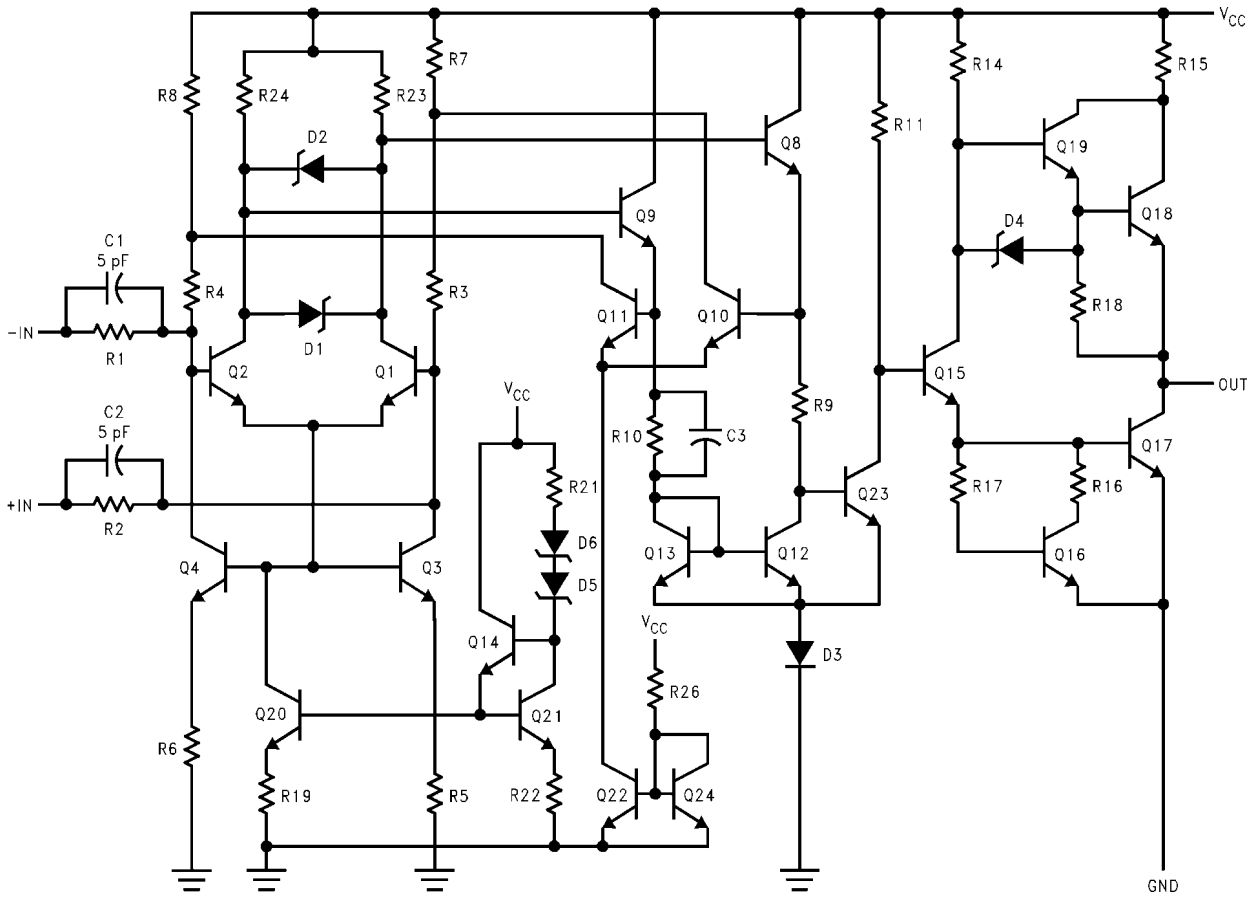

962102

FIGURE 1. Equivalent Circuit

Typical Input/Output Transfer Characteristics

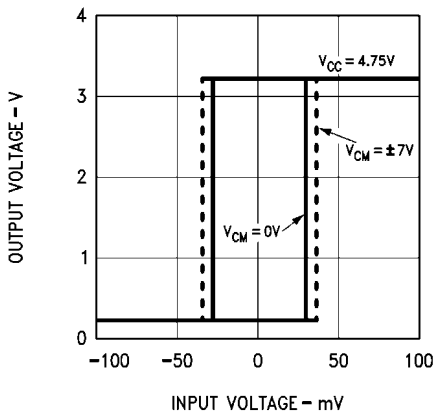

962103

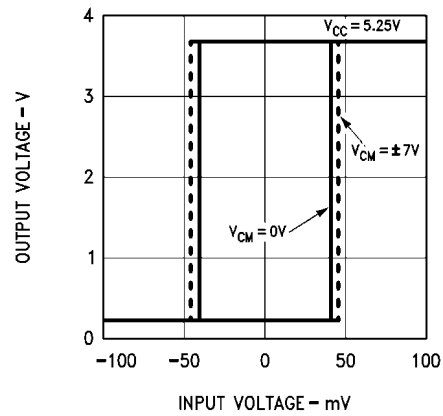

962104

AC Test Circuit and Waveforms

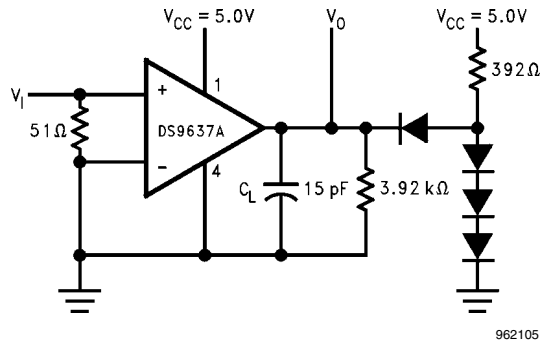

Notes:

C_L includes jig and probe capacitance.
 All diodes are FD700 or equivalent.

FIGURE 2.

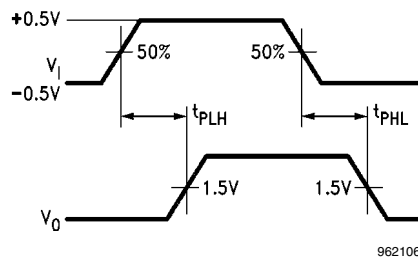

V_I
 Amplitude: 1.0V
 Offset: 0.5V
 Pulse Width: 100 ns
 PRR: 5.0 MHz
 $t_r = t_f \leq 5.0$ ns

FIGURE 3.

Typical Applications

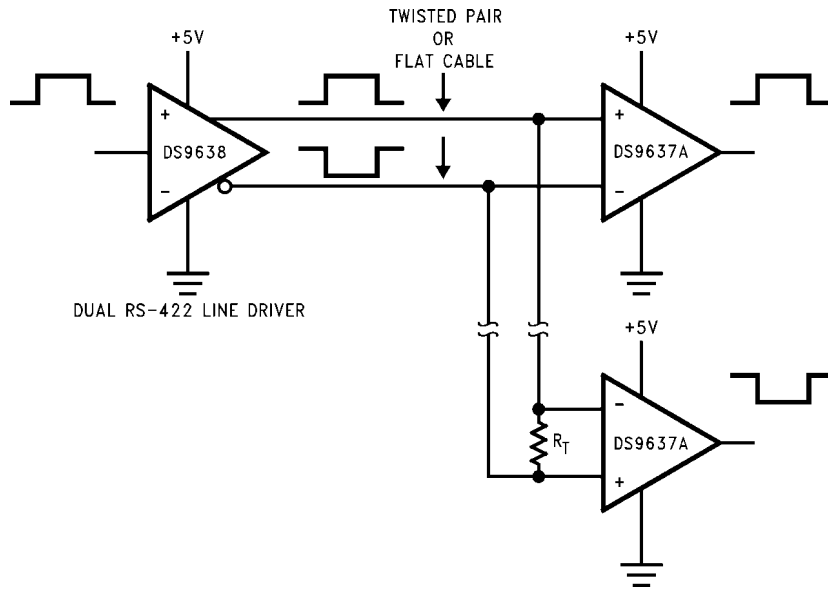

962107

Notes:

$R_T \geq 50\Omega$ for RS-422 operation.

R_T combined with input impedance of receivers must be greater than 90Ω .

FIGURE 4. RS-422 System Application (FIPS 1020) Differential Simplex Bus Transmission

Physical Dimensions inches (millimeters) unless otherwise noted

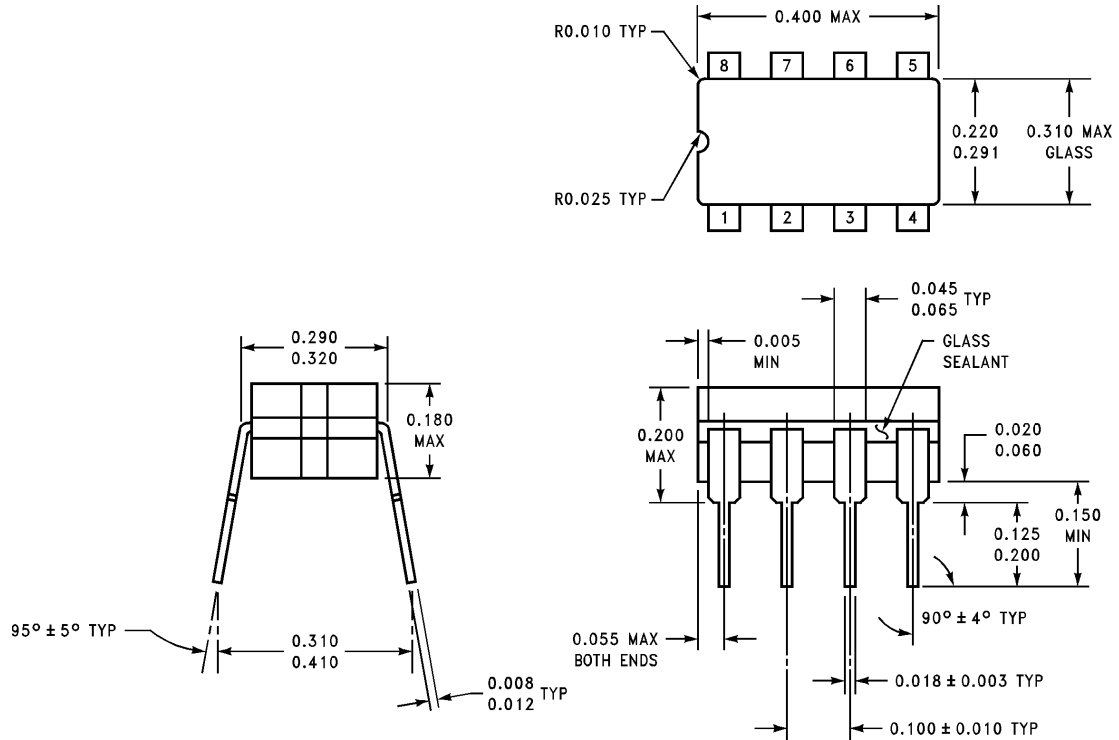

Ceramic Dual-In-Line Package (J)
Order Number DS9637AMJ/883
NS Package Number J08A

J08A (REV K)

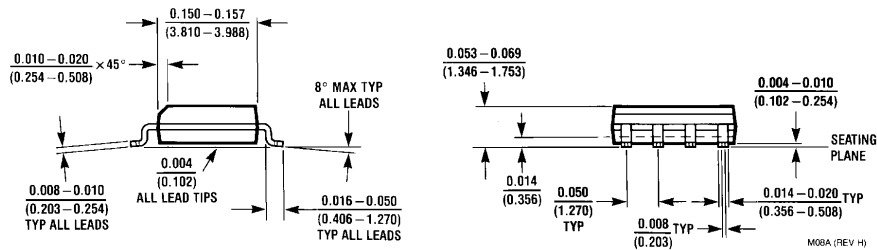
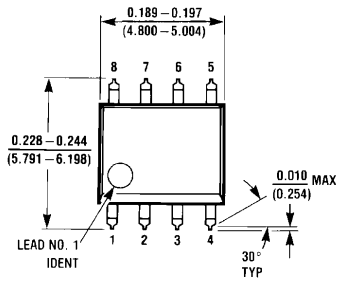

Molded Surface Mount Package (M)
Order Number DS9637ACM
NS Package Number M08A

M08A (REV H)

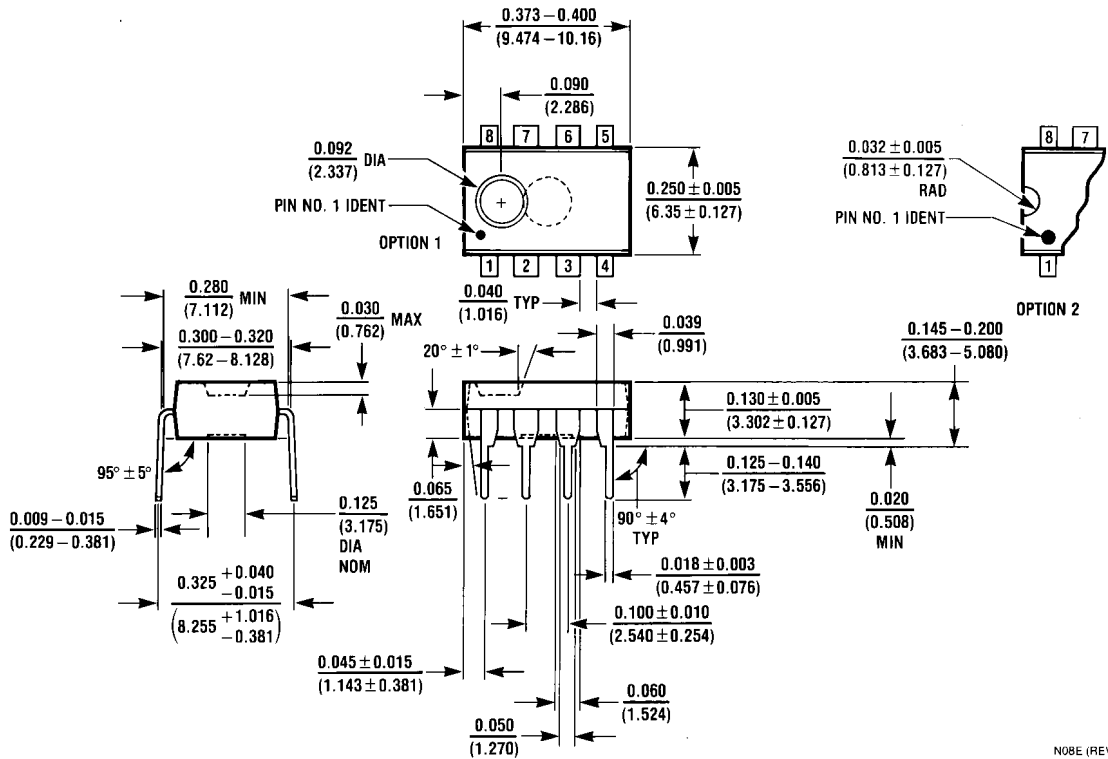

Molded Dual-In-Line Package (N)
 Order Number DS9637ACN
 NS Package Number N08E

N08E (REV F)

Notes

For more National Semiconductor product information and proven design tools, visit the following Web sites at:

Products		Design Support	
Amplifiers	www.national.com/amplifiers	WEBENCH	www.national.com/webench
Audio	www.national.com/audio	Analog University	www.national.com/AU
Clock Conditioners	www.national.com/timing	App Notes	www.national.com/appnotes
Data Converters	www.national.com/adc	Distributors	www.national.com/contacts
Displays	www.national.com/displays	Green Compliance	www.national.com/quality/green
Ethernet	www.national.com/ethernet	Packaging	www.national.com/packaging
Interface	www.national.com/interface	Quality and Reliability	www.national.com/quality
LVDS	www.national.com/lvds	Reference Designs	www.national.com/refdesigns
Power Management	www.national.com/power	Feedback	www.national.com/feedback
Switching Regulators	www.national.com/switchers		
LDOs	www.national.com/ldo		
LED Lighting	www.national.com/led		
PowerWise	www.national.com/powerwise		
Serial Digital Interface (SDI)	www.national.com/sdi		
Temperature Sensors	www.national.com/tempsensors		
Wireless (PLL/VCO)	www.national.com/wireless		

THE CONTENTS OF THIS DOCUMENT ARE PROVIDED IN CONNECTION WITH NATIONAL SEMICONDUCTOR CORPORATION ("NATIONAL") PRODUCTS. NATIONAL MAKES NO REPRESENTATIONS OR WARRANTIES WITH RESPECT TO THE ACCURACY OR COMPLETENESS OF THE CONTENTS OF THIS PUBLICATION AND RESERVES THE RIGHT TO MAKE CHANGES TO SPECIFICATIONS AND PRODUCT DESCRIPTIONS AT ANY TIME WITHOUT NOTICE. NO LICENSE, WHETHER EXPRESS, IMPLIED, ARISING BY ESTOPPEL OR OTHERWISE, TO ANY INTELLECTUAL PROPERTY RIGHTS IS GRANTED BY THIS DOCUMENT.

TESTING AND OTHER QUALITY CONTROLS ARE USED TO THE EXTENT NATIONAL DEEMS NECESSARY TO SUPPORT NATIONAL'S PRODUCT WARRANTY. EXCEPT WHERE MANDATED BY GOVERNMENT REQUIREMENTS, TESTING OF ALL PARAMETERS OF EACH PRODUCT IS NOT NECESSARILY PERFORMED. NATIONAL ASSUMES NO LIABILITY FOR APPLICATIONS ASSISTANCE OR BUYER PRODUCT DESIGN. BUYERS ARE RESPONSIBLE FOR THEIR PRODUCTS AND APPLICATIONS USING NATIONAL COMPONENTS. PRIOR TO USING OR DISTRIBUTING ANY PRODUCTS THAT INCLUDE NATIONAL COMPONENTS, BUYERS SHOULD PROVIDE ADEQUATE DESIGN, TESTING AND OPERATING SAFEGUARDS.

EXCEPT AS PROVIDED IN NATIONAL'S TERMS AND CONDITIONS OF SALE FOR SUCH PRODUCTS, NATIONAL ASSUMES NO LIABILITY WHATSOEVER, AND NATIONAL DISCLAIMS ANY EXPRESS OR IMPLIED WARRANTY RELATING TO THE SALE AND/OR USE OF NATIONAL PRODUCTS INCLUDING LIABILITY OR WARRANTIES RELATING TO FITNESS FOR A PARTICULAR PURPOSE, MERCHANTABILITY, OR INFRINGEMENT OF ANY PATENT, COPYRIGHT OR OTHER INTELLECTUAL PROPERTY RIGHT.

LIFE SUPPORT POLICY

NATIONAL'S PRODUCTS ARE NOT AUTHORIZED FOR USE AS CRITICAL COMPONENTS IN LIFE SUPPORT DEVICES OR SYSTEMS WITHOUT THE EXPRESS PRIOR WRITTEN APPROVAL OF THE CHIEF EXECUTIVE OFFICER AND GENERAL COUNSEL OF NATIONAL SEMICONDUCTOR CORPORATION. As used herein:

Life support devices or systems are devices which (a) are intended for surgical implant into the body, or (b) support or sustain life and whose failure to perform when properly used in accordance with instructions for use provided in the labeling can be reasonably expected to result in a significant injury to the user. A critical component is any component in a life support device or system whose failure to perform can be reasonably expected to cause the failure of the life support device or system or to affect its safety or effectiveness.

National Semiconductor and the National Semiconductor logo are registered trademarks of National Semiconductor Corporation. All other brand or product names may be trademarks or registered trademarks of their respective holders.

Copyright© 2007 National Semiconductor Corporation

For the most current product information visit us at www.national.com



National Semiconductor Americas Customer Support Center
 Email: new.feedback@nsc.com
 Tel: 1-800-272-9959

National Semiconductor Europe Customer Support Center
 Fax: +49 (0) 180-530-85-86
 Email: europe.support@nsc.com
 Deutsch Tel: +49 (0) 69 9508 6208
 English Tel: +49 (0) 870 24 0 2171
 Français Tel: +33 (0) 1 41 91 8790

National Semiconductor Asia Pacific Customer Support Center
 Email: ap.support@nsc.com

National Semiconductor Japan Customer Support Center
 Fax: 81-3-5639-7507
 Email: jpn.feedback@nsc.com
 Tel: 81-3-5639-7560