

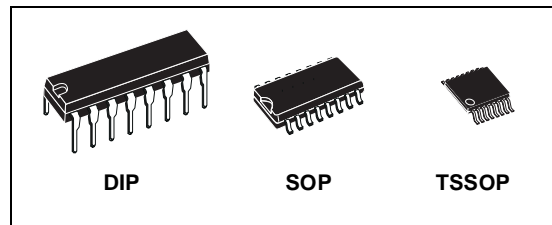

# M74HC294

## PROGRAMMABLE DIVIDER/TIMER

- HIGH SPEED :  
 $f_{MAX} = 75 \text{ MHz (TYP.) at } V_{CC} = 6V$
- LOW POWER DISSIPATION:  
 $I_{CC} = 4\mu\text{A (MAX.) at } T_A = 25^\circ\text{C}$
- HIGH NOISE IMMUNITY:  
 $V_{NIH} = V_{NIL} = 28\% V_{CC} \text{ (MIN.)}$
- SYMMETRICAL OUTPUT IMPEDANCE:  
 $|I_{OH}| = I_{OL} = 4\text{mA (MIN)}$
- BALANCED PROPAGATION DELAYS:  
 $t_{PLH} \cong t_{PHL}$
- WIDE OPERATING VOLTAGE RANGE:  
 $V_{CC} \text{ (OPR)} = 2V \text{ to } 6V$
- PIN AND FUNCTION COMPATIBLE WITH  
 74 SERIES 294



### ORDER CODES

PACKAGE	TUBE	T & R
DIP	M74HC294B1R	
SOP	M74HC294M1R	M74HC294RM13TR
TSSOP		M74HC294TTR

### DESCRIPTION

The M74HC294 is an high speed CMOS PROGRAMMABLE DIVIDER/TIMER fabricated with silicon gate C<sup>2</sup>MOS technology. This device is a programmable frequency divider and has two clock inputs, either one may be used for clock gating. (see the function table). The M74HC294 can divide from 2<sup>2</sup> to 2<sup>15</sup>. This device feature an active-low clear input to initialize

the state of all flip flops. To facilitate incoming inspection, test points (TP) are provided. All inputs are equipped with protection circuits against static discharge and transient excess voltage. This device has Q output with "Totem Pole" configuration and test point TP with "Open Drain" output configuration.

### PIN CONNECTION AND IEC LOGIC SYMBOLS

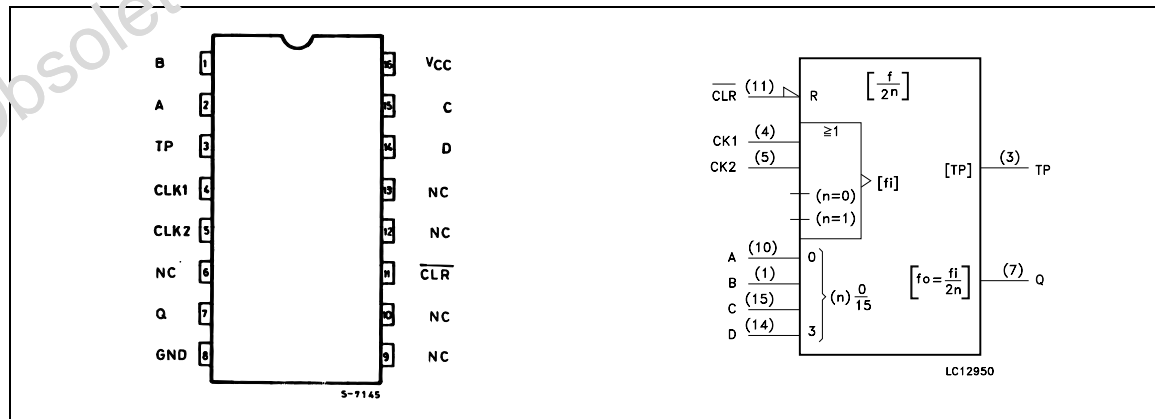

## M74HC294

### INPUT AND OUTPUT EQUIVALENT CIRCUIT (TOTEM POLE OUTPUT)

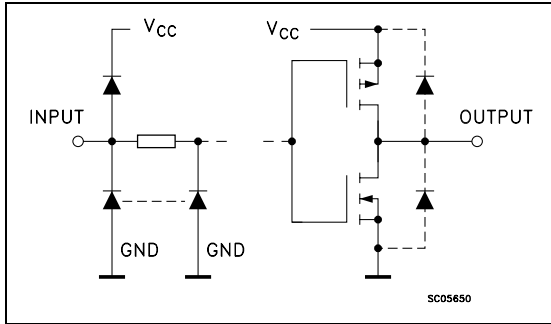

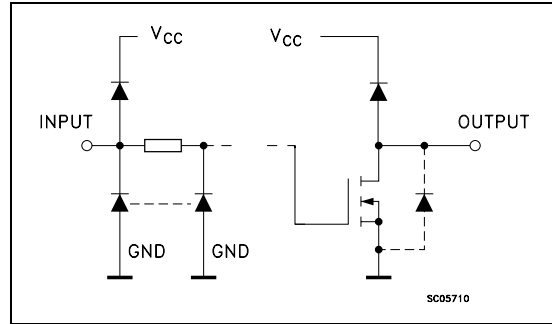

### INPUT AND OUTPUT EQUIVALENT CIRCUIT (OPEN DRAIN OUTPUT)



### PIN DESCRIPTION

PIN No	SYMBOL	NAME AND FUNCTION
4, 5	CLK1, CLK2	Input Clock
1, 2, 14, 15	A to E	Program Inputs
3	TP	Test Point Outputs
11	CLR	Clear (Active LOW)
7	Q	Output
8	GND	Ground (0V)
16	Vcc	Positive Supply Voltage

### TRUTH TABLE

CLR	CLK1	CLK2	Q OUTPUT MODE
L	X	X	CLEARED TO L
H		L	UP COUNT
H	L		
H	H	X	NO CHANGE
H	X	H	

LOGIC DIAGRAM

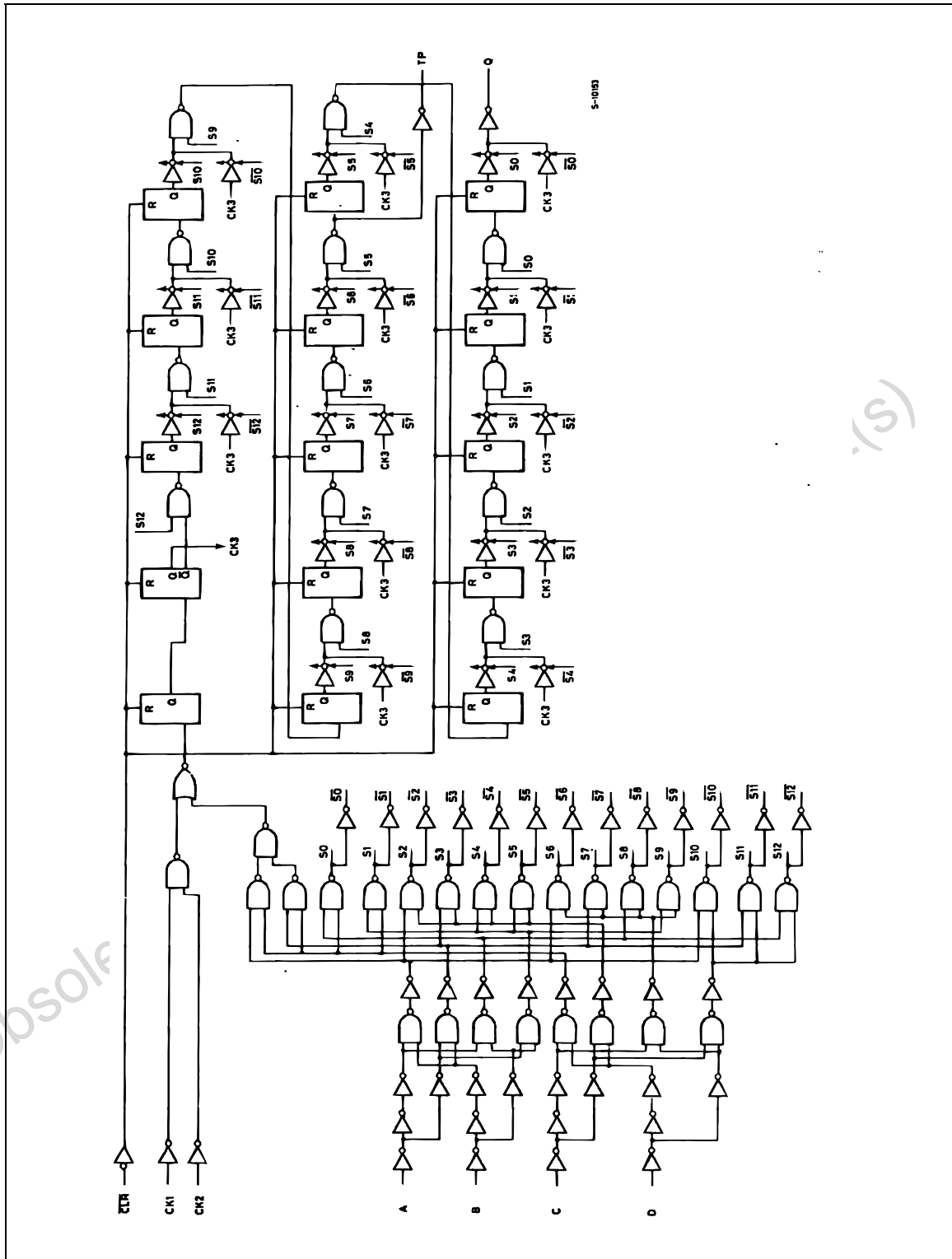

This logic diagram has not be used to estimate propagation delays



FUNCTIONAL TABLE

PROGRAMMING INPUTS				FREQUENCY DIVISION			
				Q		TP	
D	C	B	A	BINARY	DECIMAL	BINARY	DECIMAL
L	L	L	L	Inhibit	Inhibit	Inhibit	Inhibit
L	L	L	H	Inhibit	Inhibit	Inhibit	Inhibit
L	L	H	L	2 <sup>2</sup>	4	2 <sup>9</sup>	512
L	L	H	H	2 <sup>3</sup>	8	2 <sup>9</sup>	512
L	H	L	L	2 <sup>4</sup>	16	2 <sup>9</sup>	512
L	H	L	H	2 <sup>5</sup>	32	2 <sup>9</sup>	512
L	H	H	L	2 <sup>6</sup>	64	2 <sup>9</sup>	512
L	H	H	H	2 <sup>7</sup>	128	Disabled Low	
H	L	L	L	2 <sup>8</sup>	256	2 <sup>2</sup>	4
H	L	L	H	2 <sup>9</sup>	512	2 <sup>3</sup>	8
H	L	H	L	2 <sup>10</sup>	1.024	2 <sup>4</sup>	16
H	L	H	H	2 <sup>11</sup>	2.048	2 <sup>5</sup>	32
H	H	L	L	2 <sup>12</sup>	4.096	2 <sup>6</sup>	64
H	H	L	H	2 <sup>13</sup>	8.192	2 <sup>7</sup>	128
H	H	H	L	2 <sup>14</sup>	16.384	2 <sup>8</sup>	256
H	H	H	H	2 <sup>15</sup>	32.768	2 <sup>9</sup>	512

ABSOLUTE MAXIMUM RATINGS

Symbol	Parameter	Value	Unit
V <sub>CC</sub>	Supply Voltage	-0.5 to +7	V
V <sub>I</sub>	DC Input Voltage	-0.5 to V <sub>CC</sub> + 0.5	V
V <sub>O</sub>	DC Output Voltage	-0.5 to V <sub>CC</sub> + 0.5	V
I <sub>IK</sub>	DC Input Diode Current	± 20	mA
I <sub>OK</sub>	DC Output Diode Current	± 20	mA
I <sub>O</sub>	DC Output Current	± 25	mA
I <sub>CC</sub> or I <sub>GND</sub>	DC V <sub>CC</sub> or Ground Current	± 50	mA
P <sub>D</sub>	Power Dissipation	500(*)	mW
T <sub>stg</sub>	Storage Temperature	-65 to +150	°C
T <sub>L</sub>	Lead Temperature (10 sec)	300	°C

Absolute Maximum Ratings are those values beyond which damage to the device may occur. Functional operation under these conditions is not implied

(\*) 500mW at 65 °C; derate to 300mW by 10mW/°C from 65°C to 85°C

## RECOMMENDED OPERATING CONDITIONS

Symbol	Parameter	Value	Unit	
$V_{CC}$	Supply Voltage	2 to 6	V	
$V_I$	Input Voltage	0 to $V_{CC}$	V	
$V_O$	Output Voltage	0 to $V_{CC}$	V	
$T_{op}$	Operating Temperature	-55 to 125	°C	
$t_r, t_f$	Input Rise and Fall Time	$V_{CC} = 2.0V$	0 to 1000	ns
		$V_{CC} = 4.5V$	0 to 500	ns
		$V_{CC} = 6.0V$	0 to 400	ns

## DC SPECIFICATIONS

Symbol	Parameter	Test Condition		Value						Unit		
				$V_{CC}$ (V)	$T_A = 25^\circ C$			$-40$ to $85^\circ C$			$-55$ to $125^\circ C$	
					Min.	Typ.	Max.	Min.	Max.		Min.	Max.
$V_{IH}$	High Level Input Voltage	2.0		1.5			1.5		1.5	V		
		4.5		3.15			3.15		3.15			
		6.0		4.2			4.2		4.2			
$V_{IL}$	Low Level Input Voltage	2.0				0.5		0.5		V		
		4.5				1.35		1.35				
		6.0				1.8		1.8				
$V_{OH}$	High Level Output Voltage (Q)	2.0	$I_O = -20 \mu A$	1.9	2.0		1.9		1.9	V		
		4.5	$I_O = -20 \mu A$	4.4	4.5		4.4		4.4			
		6.0	$I_O = -20 \mu A$	5.9	6.0		5.9		5.9			
		4.5	$I_O = -4.0 mA$	4.18	4.31		4.13		4.10			
		6.0	$I_O = -5.2 mA$	5.68	5.8		5.63		5.60			
$V_{OL}$	Low Level Output Voltage (Q)	2.0	$I_O = 20 \mu A$		0.0	0.1		0.1		V		
		4.5	$I_O = 20 \mu A$		0.0	0.1		0.1				
		6.0	$I_O = 20 \mu A$		0.0	0.1		0.1				
		4.5	$I_O = 4.0 mA$		0.17	0.26		0.33			0.40	
		6.0	$I_O = 5.2 mA$		0.18	0.26		0.33			0.40	
$V_{OL}$	Low Level Output Voltage (TP)	2.0	$I_O = 20 \mu A$		0.0	0.1		0.1		V		
		4.5	$I_O = 20 \mu A$		0.0	0.1		0.1				
		6.0	$I_O = 20 \mu A$		0.0	0.1		0.1				
		4.5	$I_O = 1.0 mA$		0.17	0.26		0.33			0.40	
		6.0	$I_O = 1.3 mA$		0.18	0.26		0.33			0.40	
$I_I$	Input Leakage Current	6.0	$V_I = V_{CC}$ or GND			$\pm 0.1$		$\pm 1$		$\mu A$		
$I_{CC}$	Quiescent Supply Current	6.0	$V_I = V_{CC}$ or GND			4		40		80	$\mu A$	

## M74HC294

### AC ELECTRICAL CHARACTERISTICS ( $C_L = 50 \text{ pF}$ , Input $t_r = t_f = 6 \text{ ns}$ )

Symbol	Parameter	Test Condition		Value						Unit	
		$V_{CC}$ (V)		$T_A = 25^\circ\text{C}$			$-40 \text{ to } 85^\circ\text{C}$		$-55 \text{ to } 125^\circ\text{C}$		
				Min.	Typ.	Max.	Min.	Max.	Min.		Max.
$t_{TLH}$ $t_{THL}$	Output Transition Time (Q)	2.0			30	75		95		110	ns
		4.5			8	15		19		22	
		6.0			7	13		16		19	
$t_{TLH}$ $t_{THL}$	Output Transition Time (TP)	2.0			116	225		280		340	ns
		4.5			29	45		56		68	
		6.0			25	38		48		57	
$t_{PLH}$ $t_{PHL}$	Propagation Delay Time (CLK - Q)	2.0			145	330		415			ns
		4.5			43	66		83		15	
		6.0			37	56		71		84	
$t_{PHL}$	Propagation Delay Time (CLR - Q)	2.0			110	260		325		390	ns
		4.5			34	52		65		78	
		6.0			29	44		55		66	
$f_{MAX}$	Maximum Clock Frequency	2.0			6.0	20		5		4	MHz
		4.5			32	64		26		21	
		6.0			38	75		31		25	
$t_{W(L)}$ $t_{W(H)}$	Minimum Pulse Width (CLK)	2.0			40	75		95		110	ns
		4.5			8	15		19		22	
		6.0			7	13		16		20	
$t_{W(L)}$	Minimum Pulse Width (CLR)	2.0			40	100		125		150	ns
		4.5			10	20		25		30	
		6.0			9	17		21		26	
$t_{REM}$	Minimum Removal Time	2.0				0		0		0	ns
		4.5				0		0		0	
		6.0				0		0		0	

### CAPACITIVE CHARACTERISTICS

Symbol	Parameter	Test Condition		Value						Unit	
		$V_{CC}$ (V)		$T_A = 25^\circ\text{C}$			$-40 \text{ to } 85^\circ\text{C}$		$-55 \text{ to } 125^\circ\text{C}$		
				Min.	Typ.	Max.	Min.	Max.	Min.		Max.
$C_{IN}$	Input Capacitance	5.0			5	10		10		10	pF
$C_{PD}$	Power Dissipation Capacitance (note 1)	5.0			23						pF

1)  $C_{PD}$  is defined as the value of the IC's internal equivalent capacitance which is calculated from the operating current consumption without load. (Refer to Test Circuit). Average operating current can be obtained by the following equation.  $I_{CC(opr)} = C_{PD} \times V_{CC} \times f_{IN} + I_{CC}$

## TEST CIRCUIT

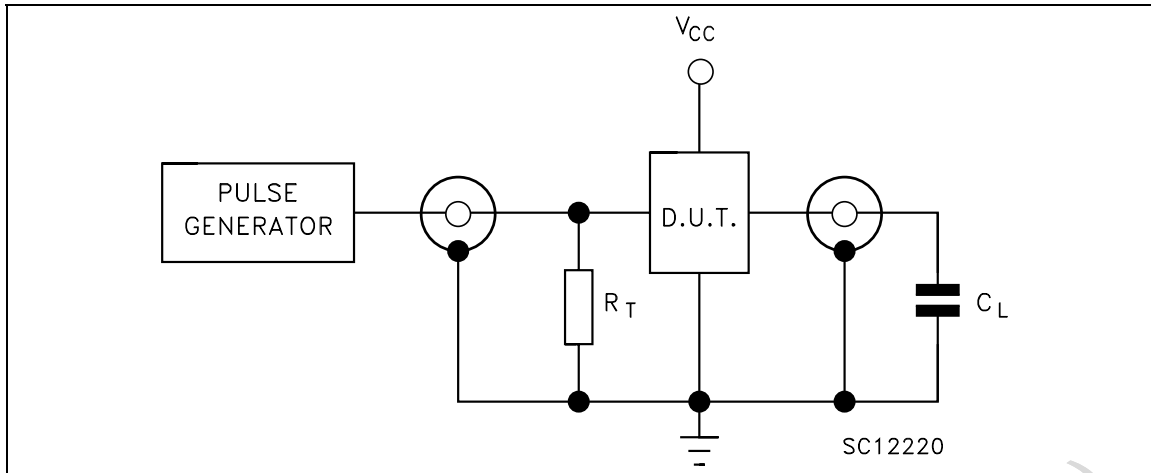

$C_L$  = 50pF or equivalent (includes jig and probe capacitance)  
 $R_T$  =  $Z_{OUT}$  of pulse generator (typically 50 $\Omega$ )

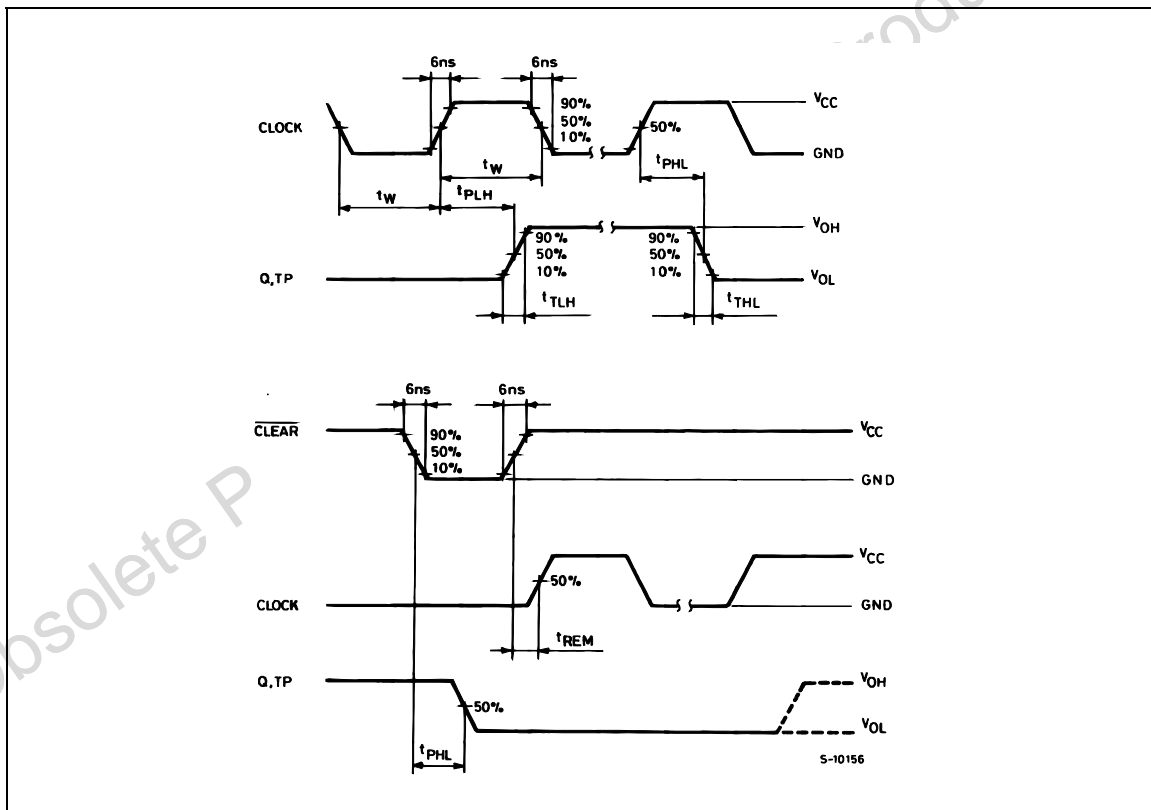
SWITCHING CHARACTERISTICS TEST WAVEFORM : ( $f=1\text{MHz}$ ; 50% duty cycle)

**Plastic DIP-16 (0.25) MECHANICAL DATA**

DIM.	mm.			inch		
	MIN.	TYP	MAX.	MIN.	TYP.	MAX.
a1	0.51			0.020		
B	0.77		1.65	0.030		0.065
b		0.5			0.020	
b1		0.25			0.010	
D			20			0.787
E		8.5			0.335	
e		2.54			0.100	
e3		17.78			0.700	
F			7.1			0.280
I			5.1			0.201
L		3.3			0.130	
Z			1.27			0.050

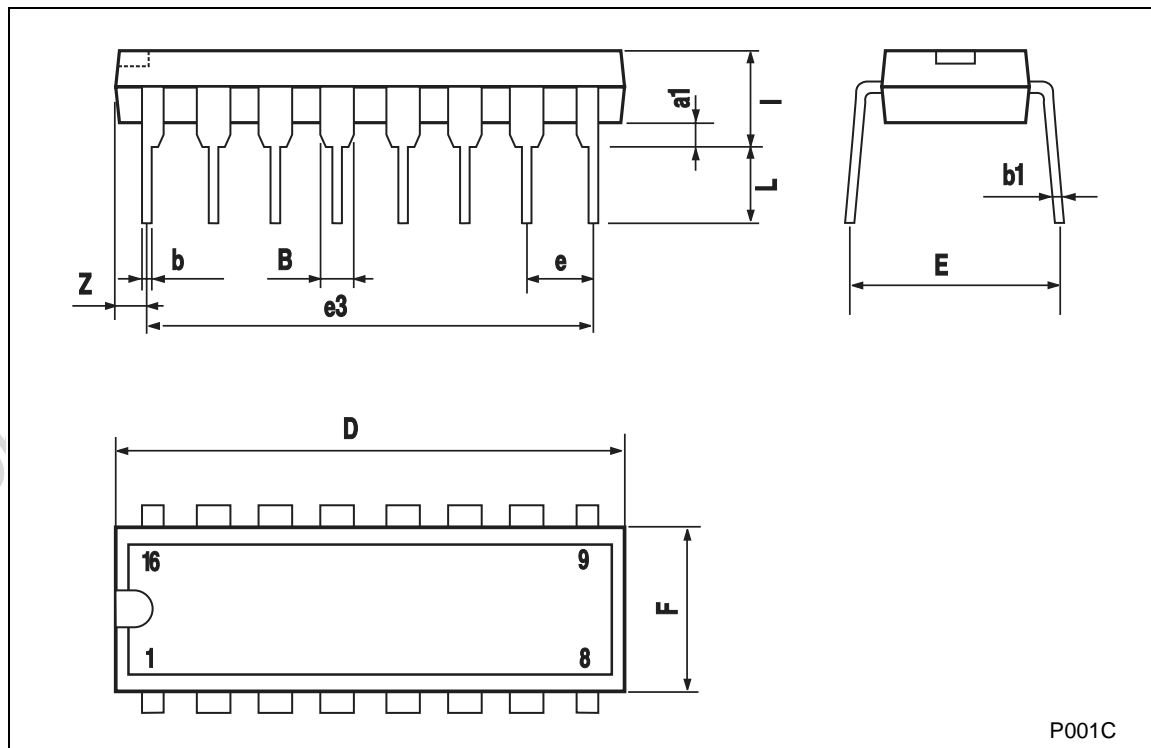



## SO-16 MECHANICAL DATA

DIM.	mm.			inch		
	MIN.	TYP	MAX.	MIN.	TYP.	MAX.
A			1.75			0.068
a1	0.1		0.2	0.003		0.007
a2			1.65			0.064
b	0.35		0.46	0.013		0.018
b1	0.19		0.25	0.007		0.010
C		0.5			0.019	
c1	45° (typ.)					
D	9.8		10	0.385		0.393
E	5.8		6.2	0.228		0.244
e		1.27			0.050	
e3		8.89			0.350	
F	3.8		4.0	0.149		0.157
G	4.6		5.3	0.181		0.208
L	0.5		1.27	0.019		0.050
M			0.62			0.024
S	8° (max.)					

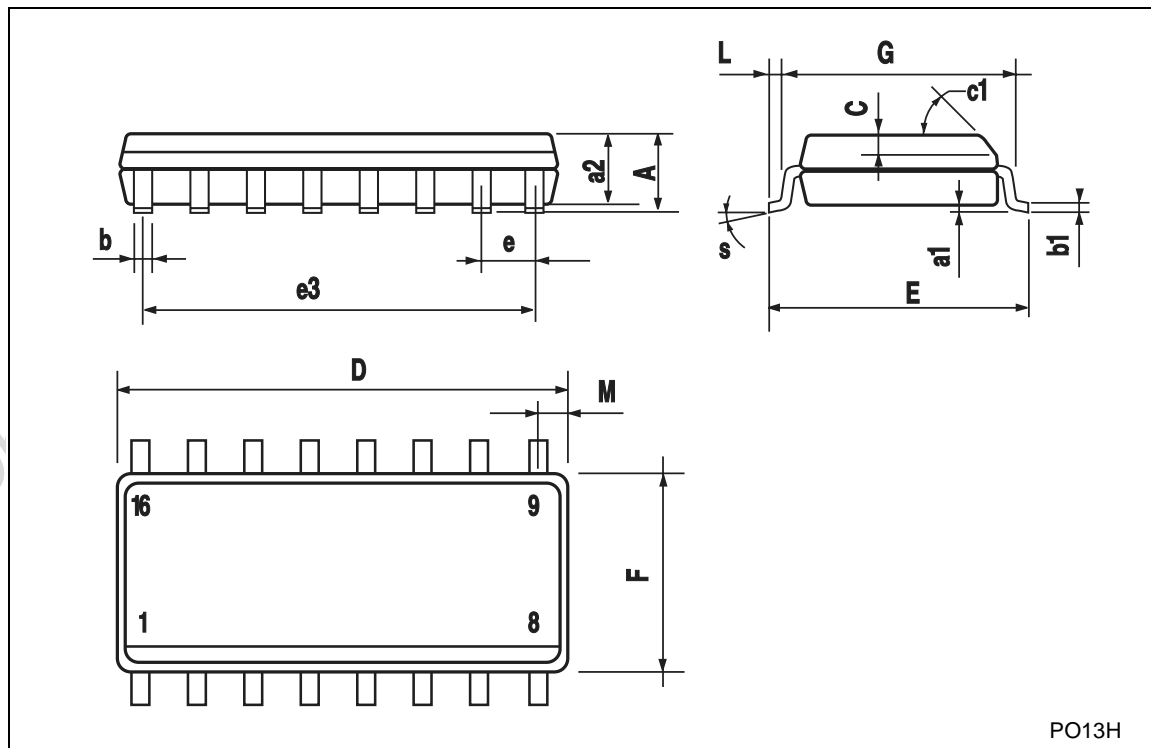

PO13H

## TSSOP16 MECHANICAL DATA

DIM.	mm.			inch		
	MIN.	TYP	MAX.	MIN.	TYP.	MAX.
A			1.2			0.047
A1	0.05		0.15	0.002	0.004	0.006
A2	0.8	1	1.05	0.031	0.039	0.041
b	0.19		0.30	0.007		0.012
c	0.09		0.20	0.004		0.0089
D	4.9	5	5.1	0.193	0.197	0.201
E	6.2	6.4	6.6	0.244	0.252	0.260
E1	4.3	4.4	4.48	0.169	0.173	0.176
e		0.65 BSC			0.0256 BSC	
K	0°		8°	0°		8°
L	0.45	0.60	0.75	0.018	0.024	0.030

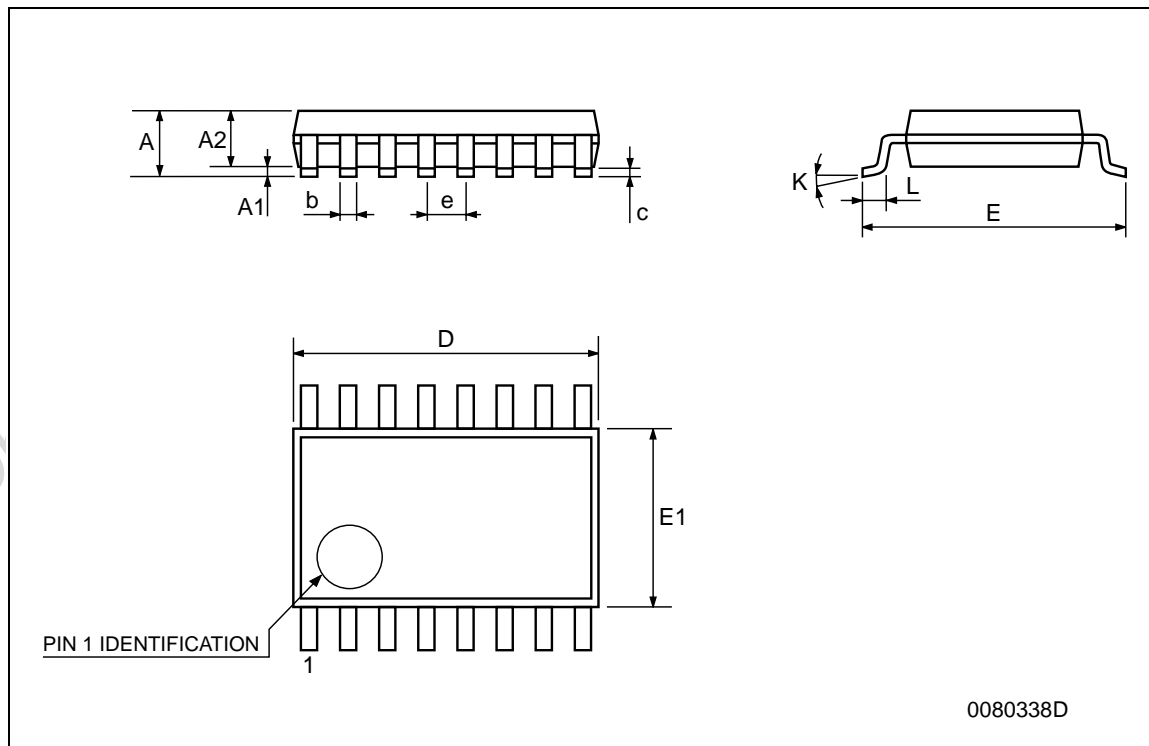

Obsolete Product(s) - Obsolete Product(s)

Information furnished is believed to be accurate and reliable. However, STMicroelectronics assumes no responsibility for the consequences of use of such information nor for any infringement of patents or other rights of third parties which may result from its use. No license is granted by implication or otherwise under any patent or patent rights of STMicroelectronics. Specifications mentioned in this publication are subject to change without notice. This publication supersedes and replaces all information previously supplied. STMicroelectronics products are not authorized for use as critical components in life support devices or systems without express written approval of STMicroelectronics.

© The ST logo is a registered trademark of STMicroelectronics

© 2001 STMicroelectronics - Printed in Italy - All Rights Reserved  
STMicroelectronics GROUP OF COMPANIES

Australia - Brazil - China - Finland - France - Germany - Hong Kong - India - Italy - Japan - Malaysia - Malta - Morocco  
Singapore - Spain - Sweden - Switzerland - United Kingdom

© <http://www.st.com>

