

# DS89C21

## Differential CMOS Line Driver and Receiver Pair

### General Description

The DS89C21 is a differential CMOS line driver and receiver pair, designed to meet the requirements of TIA/EIA-422-A (RS-422) electrical characteristics interface standard. The DS89C21 provides one driver and one receiver in a minimum footprint. The device is offered in an 8-pin SOIC package.

The CMOS design minimizes the supply current to 6 mA, making the device ideal for use in battery powered or power conscious applications.

The driver features a fast transition time specified at 2.2 ns, and a maximum differential skew of 2 ns making the driver ideal for use in high speed applications operating above 10 MHz.

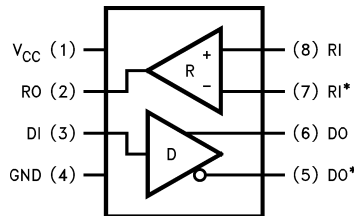
The receiver can detect signals as low as 200 mV, and also incorporates hysteresis for noise rejection. Skew is specified at 4 ns maximum.

The DS89C21 is compatible with TTL and CMOS levels (DI and RO).

### Features

- Meets TIA/EIA-422-A (RS-422) and CCITT V.11 recommendation
- LOW POWER design— 15 mW typical
- Guaranteed AC parameters:
  - Maximum driver skew 2.0 ns
  - Maximum receiver skew 4.0 ns
- Extended temperature range: -40°C to +85°C
- Available in SOIC packaging
- Operates over 20 Mbps
- Receiver OPEN input failsafe feature

### Connection Diagram



01175301

Order Number DS89C21TM  
See NS Package Number M08A

### Truth Tables

#### Driver

Input	Outputs	
DI	DO	DO*
H	H	L
L	L	H

#### Receiver

Inputs	Output
RI-RI*	RO
$V_{DIFF} \geq +200 \text{ mV}$	H
$V_{DIFF} \leq -200 \text{ mV}$	L
OPEN†	H

†Non-terminated

**Absolute Maximum Ratings** (Note 1)

If Military/Aerospace specified devices are required, please contact the National Semiconductor Sales Office/Distributors for availability and specifications.

Supply Voltage ( $V_{CC}$ )	7V
Driver Input Voltage (DI)	-1.5V to $V_{CC} + 1.5V$
Driver Output Voltage (DO, DO <sup>*</sup> )	-0.5V to +7V
Receiver Input Voltage— $V_{CM}$ (RI, RI <sup>*</sup> )	±14V
Differential Receiver Input Voltage— $V_{DIFF}$ (RI, RI <sup>*</sup> )	±14V
Receiver Output Voltage (RO)	-0.5V to $V_{CC} + 0.5V$
Receiver Output Current (RO)	±25 mA
Storage Temperature Range	

( $T_{STG}$ )	-65°C to +150°C
Lead Temperature ( $T_L$ ) (Soldering 4 sec.)	+260°C
Maximum Junction Temperature	150°C
Maximum Package Power Dissipation @+25°C	
M Package	714 mW
Derate M Package	5.7 mW/°C above +25°C

**Recommended Operating Conditions**

	Min	Max	Units
Supply Voltage ( $V_{CC}$ )	4.50	5.50	V
Operating Temperature ( $T_A$ )	-40	+85	°C
Input Rise or Fall Time (DI)		500	ns

**Electrical Characteristics** (Notes 2, 3)

Over recommended supply voltage and operating temperature ranges, unless otherwise specified.

Symbol	Parameter	Conditions	Pin	Min	Typ	Max	Units
<b>DRIVER CHARACTERISTICS</b>							
$V_{IH}$	Input Voltage HIGH		DI	2.0		$V_{CC}$	V
$V_{IL}$	Input Voltage LOW			GND		0.8	V
$I_{IH}, I_{IL}$	Input Current	$V_{IN} = V_{CC}, GND, 2.0V, 0.8V$			0.05	±10	μA
$V_{CL}$	Input Clamp Voltage	$I_{IN} = -18 mA$				-1.5	V
$V_{OD1}$	Unloaded Output Voltage	No Load	DO,		4.2	6.0	V
$V_{OD2}$	Differential Output Voltage	$R_L = 100\Omega$	DO*	2.0	3.0		V
$\Delta V_{OD2}$	Change in Magnitude of $V_{OD2}$ for Complementary Output States				5.0	400	mV
$V_{OD3}$	Differential Output Voltage	$R_L = 150\Omega$		2.1	3.1		V
$V_{OD4}$	Differential Output Voltage	$R_L = 3.9 k\Omega$			4.0	6.0	V
$V_{OC}$	Common Mode Voltage	$R_L = 100\Omega$			2.0	3.0	V
$\Delta V_{OC}$	Change in Magnitude of $V_{OC}$ for Complementary Output States				2.0	400	mV
$I_{OSD}$	Output Short Circuit Current	$V_{OUT} = 0V$		-30	-115	-150	mA
$I_{OFF}$	Output Leakage Current	$V_{CC} = 0V$			0.03	+100	μA
					-0.08	-100	μA
<b>RECEIVER CHARACTERISTICS</b>							
$V_{TL}, V_{TH}$	Differential Thresholds	$V_{IN} = +7V, 0V, -7V$	RI,	-200	±25	+200	mV
$V_{HYS}$	Hysteresis	$V_{CM} = 0V$	RI*	20	50		mV
$R_{IN}$	Input Impedance	$V_{IN} = -7V, +7V, Other = 0V$		5.0	9.5		kΩ
$I_{IN}$	Input Current	Other Input = 0V, $V_{CC} = 5.5V$ and $V_{CC} = 0V$			+1.0	+1.5	mA
					0	+0.22	mA
					-0.04	mA	
				0	-0.41	mA	
					-1.25	-2.5	mA

## Electrical Characteristics (Notes 2, 3) (Continued)

Over recommended supply voltage and operating temperature ranges, unless otherwise specified.

Symbol	Parameter	Conditions	Pin	Min	Typ	Max	Units	
<b>RECEIVER CHARACTERISTICS</b>								
$V_{OH}$	Output HIGH Voltage	$I_{OH} = -6 \text{ mA}$	RO	$V_{DIFF} = +1\text{V}$	3.8	4.9		V
				$V_{DIFF} = \text{OPEN}$	3.8	4.9		V
$V_{OL}$	Output LOW Voltage	$I_{OL} = +6 \text{ mA}, V_{DIFF} = -1\text{V}$			0.08	0.3	V	
$I_{OSR}$	Output Short Circuit Current	$V_{OUT} = 0\text{V}$		-25	-85	-150	mA	
<b>DRIVER AND RECEIVER CHARACTERISTICS</b>								
$I_{CC}$	Supply Current	No Load	$V_{CC}$	$DI = V_{CC} \text{ or GND}$		3.0	6	mA
				$DI = 2.4\text{V or }0.5\text{V}$		3.8	12	mA

## Switching Characteristics (Note 3)

Over recommended supply voltage and operating temperature ranges, unless otherwise specified.

Symbol	Parameter	Conditions	Min	Typ	Max	Units				
<b>DIFFERENTIAL DRIVER CHARACTERISTICS</b>										
$t_{PLHD}$	Propagation Delay LOW to HIGH	$R_L = 100\Omega$ $C_L = 50 \text{ pF}$	(Figures 2, 3)		2	4.9	10	ns		
$t_{PHLD}$	Propagation Delay HIGH to LOW				2	4.5	10	ns		
$t_{SKD}$	Skew, $ t_{PLHD} - t_{PHLD} $					0.4	2.0	ns		
$t_{TLH}$	Transition Time LOW to HIGH	(Figures 2, 4)			2.2	9	ns			
$t_{THL}$	Transition Time HIGH to LOW				2.1	9	ns			
<b>RECEIVER CHARACTERISTICS</b>										
$t_{PLH}$	Propagation Delay LOW to HIGH	$C_L = 50 \text{ pF}$ $V_{DIFF} = 2.5\text{V}$ $V_{CM} = 0\text{V}$	(Figures 5, 6)		6	18	30	ns		
$t_{PHL}$	Propagation Delay HIGH to LOW				6	17.5	30	ns		
$t_{SK}$	Skew, $ t_{PLH} - t_{PHL} $					0.5	4.0	ns		
$t_r$	Rise Time				(Figure 7)			2.5	9	ns
$t_f$	Fall Time							2.1	9	ns

**Note 1:** "Absolute Maximum Ratings" are those values beyond which the safety of the device cannot be guaranteed. They are not meant to imply that the devices should be operated at these limits. The tables of "Electrical Characteristics" specify conditions for device operation.

**Note 2:** Current into device pins is defined as positive. Current out of device pins is defined as negative. All voltages are referenced to ground unless otherwise specified.

**Note 3:** All typicals are given for  $V_{CC} = 5.0\text{V}$  and  $T_A = 25^\circ\text{C}$ .

**Note 4:**  $f = 1 \text{ MHz}$ ,  $t_r$  and  $t_f \leq 6 \text{ ns}$ .

**Note 5:** ESD Rating: HBM (1.5 k $\Omega$ , 100 pF) all pins  $\geq 2000\text{V}$ .

EIAJ (0 $\Omega$ , 200 pF)  $\geq 250\text{V}$

## Parameter Measurement Information

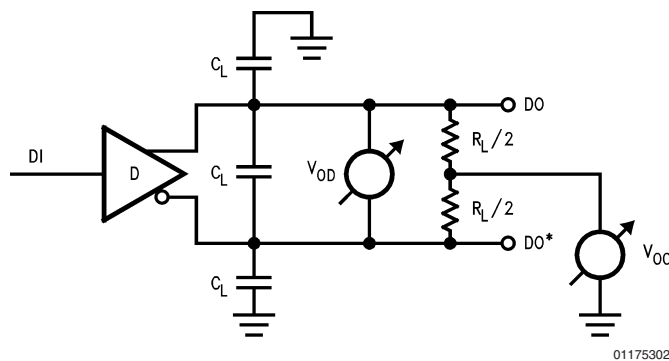
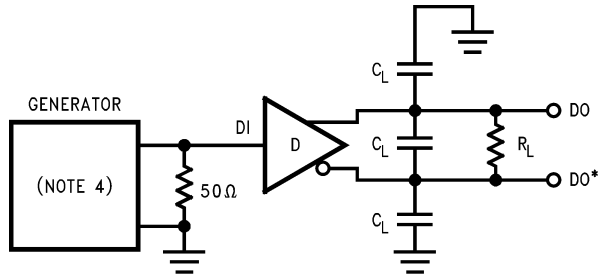


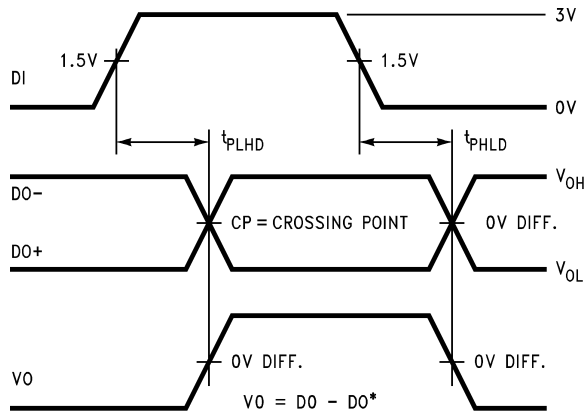
FIGURE 1.  $V_{OD}$  and  $V_{OC}$  Test Circuit

Parameter Measurement Information (Continued)



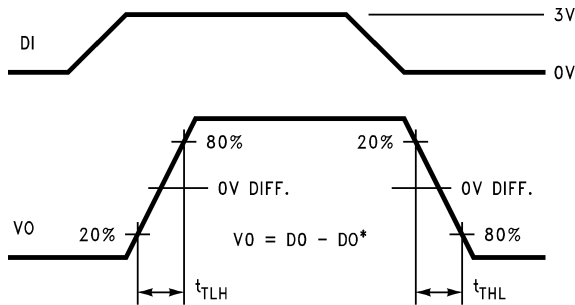
01175303

FIGURE 2. Driver Propagation Delay Test Circuit



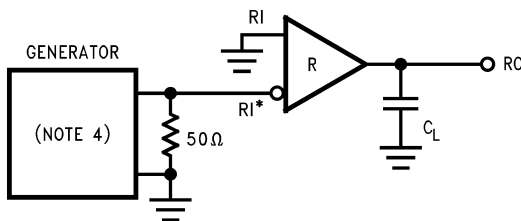
01175304

FIGURE 3. Driver Differential Propagation Delay Timing



01175305

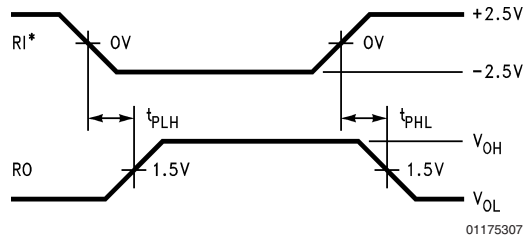
FIGURE 4. Driver Differential Transition Timing



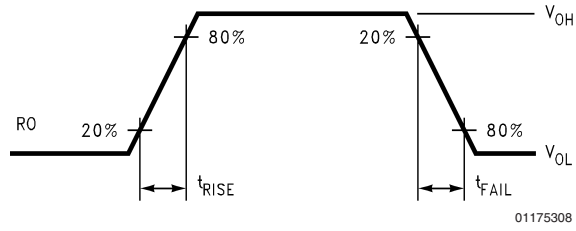
01175306

FIGURE 5. Receiver Propagation Delay Test Circuit

**Parameter Measurement Information** (Continued)

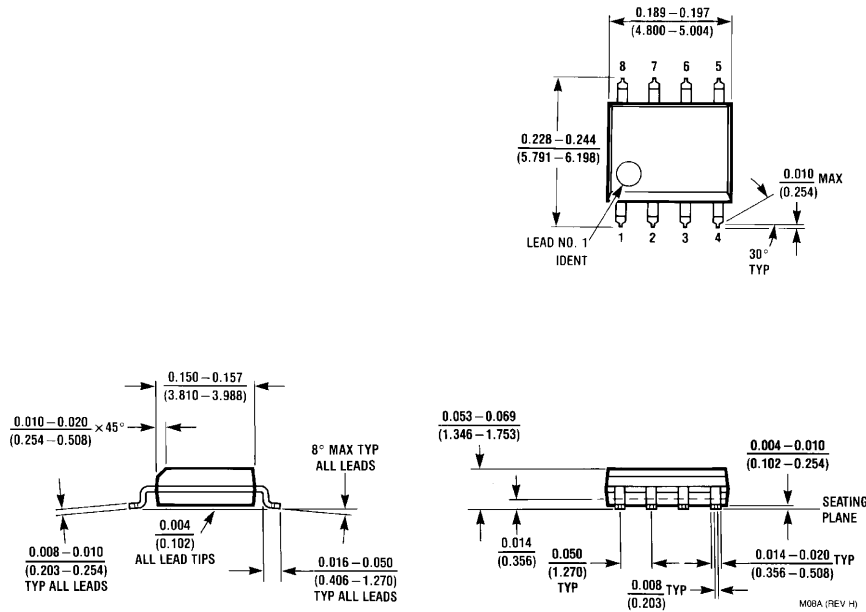


**FIGURE 6. Receiver Propagation Delay Timing**



**FIGURE 7. Receiver Rise and Fall Times**

**Physical Dimensions** inches (millimeters) unless otherwise noted



Order Number DS89C21TM  
NS Package Number M08A

National does not assume any responsibility for use of any circuitry described, no circuit patent licenses are implied and National reserves the right at any time without notice to change said circuitry and specifications.

For the most current product information visit us at [www.national.com](http://www.national.com).


**LIFE SUPPORT POLICY**

NATIONAL'S PRODUCTS ARE NOT AUTHORIZED FOR USE AS CRITICAL COMPONENTS IN LIFE SUPPORT DEVICES OR SYSTEMS WITHOUT THE EXPRESS WRITTEN APPROVAL OF THE PRESIDENT AND GENERAL COUNSEL OF NATIONAL SEMICONDUCTOR CORPORATION. As used herein:

1. Life support devices or systems are devices or systems which, (a) are intended for surgical implant into the body, or (b) support or sustain life, and whose failure to perform when properly used in accordance with instructions for use provided in the labeling, can be reasonably expected to result in a significant injury to the user.
2. A critical component is any component of a life support device or system whose failure to perform can be reasonably expected to cause the failure of the life support device or system, or to affect its safety or effectiveness.

**BANNED SUBSTANCE COMPLIANCE**

National Semiconductor certifies that the products and packing materials meet the provisions of the Customer Products Stewardship Specification (CSP-9-111C2) and the Banned Substances and Materials of Interest Specification (CSP-9-111S2) and contain no "Banned Substances" as defined in CSP-9-111S2.

 **National Semiconductor**  
Americas Customer  
Support Center  
Email: [new.feedback@nsc.com](mailto:new.feedback@nsc.com)  
Tel: 1-800-272-9959

**National Semiconductor**  
Europe Customer Support Center  
Fax: +49 (0) 180-530 85 86  
Email: [europa.support@nsc.com](mailto:europa.support@nsc.com)  
Deutsch Tel: +49 (0) 69 9508 6208  
English Tel: +44 (0) 870 24 0 2171  
Français Tel: +33 (0) 1 41 91 8790

**National Semiconductor**  
Asia Pacific Customer  
Support Center  
Email: [ap.support@nsc.com](mailto:ap.support@nsc.com)

**National Semiconductor**  
Japan Customer Support Center  
Fax: 81-3-5639-7507  
Email: [jpn.feedback@nsc.com](mailto:jpn.feedback@nsc.com)  
Tel: 81-3-5639-7560

[www.national.com](http://www.national.com)