

## DS34C86T

### Quad CMOS Differential Line Receiver

#### General Description

The DS34C86T is a quad differential line receiver designed to meet the RS-422, RS-423, and Federal Standards 1020 and 1030 for balanced and unbalanced digital data transmission, while retaining the low power characteristics of CMOS.

The DS34C86T has an input sensitivity of 200 mV over the common mode input voltage range of  $\pm 7V$ . Hysteresis is provided to improve noise margin and discourage output instability for slowly changing input waveforms.

The DS34C86T features internal pull-up and pull-down resistors which prevent output oscillation on unused channels.

Separate enable pins allow independent control of receiver pairs. The TRI-STATE<sup>®</sup> outputs have 6 mA source and sink capability. The DS34C86T is pin compatible with the DS3486.

#### Features

- CMOS design for low power
- $\pm 0.2V$  sensitivity over the input common mode voltage range
- Typical propagation delays: 19 ns
- Typical input hysteresis: 60 mV
- Inputs won't load line when  $V_{CC} = 0V$
- Meets the requirements of EIA standard RS-422
- TRI-STATE outputs for system bus compatibility
- Available in surface mount
- Open input Failsafe feature, output high for open input

#### Logic Diagram

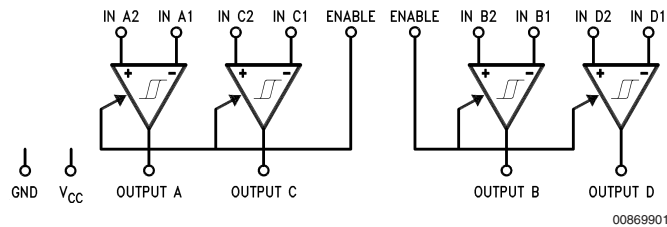

#### Connection Diagram

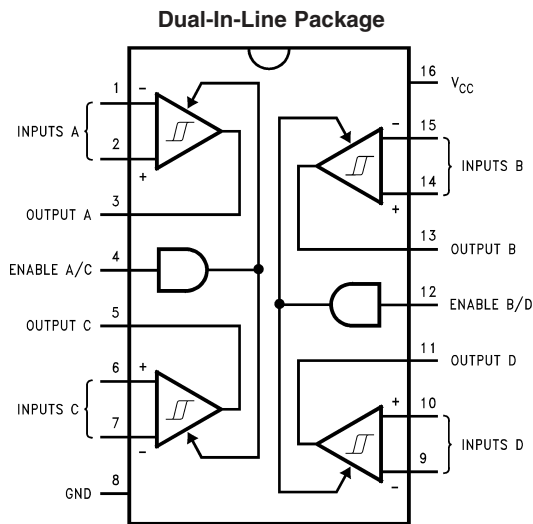

Top View

Order Number DS34C86TM, and DS34C86TN  
See NS Package Number M16A and N16E

#### Truth Table

Enable	Input	Output
L	X	Z
H	$V_{ID} \geq V_{TH} (\text{Max})$	H
H	$V_{ID} \leq V_{TH} (\text{Min})$	L
H	Open*	H

\*Open, not terminated  
Z = TRI-STATE

TRI-STATE<sup>®</sup> is a registered trademark of National Semiconductor Corporation.

**Absolute Maximum Ratings** (Notes 1,

2)

If Military/Aerospace specified devices are required, please contact the National Semiconductor Sales Office/Distributors for availability and specifications.

Supply Voltage ( $V_{CC}$ )	7V
Input Common Mode Range ( $V_{CM}$ )	$\pm 14V$
Differential Input Voltage ( $V_{DIFF}$ )	$\pm 14V$
Enable Input Voltage ( $V_{IN}$ )	7V
Storage Temperature Range ( $T_{STG}$ )	$-65^{\circ}C$ to $+150^{\circ}C$
Lead Temperature (Soldering 4 sec)	$260^{\circ}C$

Maximum Power Dissipation at  $25^{\circ}C$  (Note 5)

Plastic "N" Package	1645 mW
SOIC Package	1190 mW
Current Per Output	$\pm 25$ mA

This device does not meet 2000V ESD rating. (Note 4)

**Operating Conditions**

	Min	Max	Unit
Supply Voltage ( $V_{CC}$ )	4.50	5.50	V
Operating Temperature Range ( $T_A$ )	$-40$	$+85$	$^{\circ}C$
Enable Input Rise or Fall Times		500	ns

**DC Electrical Characteristics** (Note 3)

$V_{CC} = 5V \pm 10\%$  (unless otherwise specified)

Symbol	Parameter	Conditions	Min	Typ	Max	Units
$V_{TH}$	Minimum Differential Input Voltage	$V_{OUT} = V_{OH}$ or $V_{OL}$ $-7V < V_{CM} < +7V$	-200	35	+200	mV
$R_{IN}$	Input Resistance	$V_{IN} = -7V, +7V$ (Other Input = GND)	5.0	6.8	10	k $\Omega$
$I_{IN}$	Input Current (Under Test)	$V_{IN} = +10V$ , Other Input = GND $V_{IN} = -10V$ , Other Input = GND		+1.1 -2.0	+1.5 -2.5	mA
$V_{OH}$	Minimum High Level Output Voltage	$V_{CC} = \text{Min.}$ , $V_{(DIFF)} = +1V$ $I_{OUT} = -6.0$ mA	3.8	4.2		V
$V_{OL}$	Maximum Low Level Output Voltage	$V_{CC} = \text{Max.}$ , $V_{(DIFF)} = -1V$ $I_{OUT} = 6.0$ mA		0.2	0.3	V
$V_{IH}$	Minimum Enable High Input Level Voltage		2.0			V
$V_{IL}$	Maximum Enable Low Input Level Voltage				0.8	V
$I_{OZ}$	Maximum TRI-STATE Output Leakage Current	$V_{OUT} = V_{CC}$ or GND, TRI-STATE Control = $V_{IL}$		$\pm 0.5$	$\pm 5.0$	$\mu A$
$I_I$	Maximum Enable Input Current	$V_{IN} = V_{CC}$ or GND			$\pm 1.0$	$\mu A$
$I_{CC}$	Quiescent Power Supply Current	$V_{CC} = \text{Max.}$ , $V_{(DIFF)} = +1V$		16	23	mA
$V_{HYST}$	Input Hysteresis	$V_{CM} = 0V$		60		mV

**AC Electrical Characteristics** (Note 3)

$V_{CC} = 5V \pm 10\%$  (unless otherwise specified) (Figures 1, 2, 3)

Symbol	Parameter	Conditions	Min	Typ	Max	Units
$t_{PLH}$ , $t_{PHL}$	Propagation Delay Input to Output	$C_L = 50$ pF $V_{DIFF} = 2.5V$ $V_{CM} = 0V$		19	30	ns
$t_{RISE}$ , $t_{FALL}$	Output Rise and Fall Times	$C_L = 50$ pF $V_{DIFF} = 2.5V$ $V_{CM} = 0V$		4	9	ns
$t_{PLZ}$ , $t_{PHZ}$	Propagation Delay ENABLE to Output	$C_L = 50$ pF $R_L = 1000\Omega$		13	18	ns

## AC Electrical Characteristics (Note 3) (Continued)

$V_{CC} = 5V \pm 10\%$  (unless otherwise specified) (Figures 1, 2, 3)

Symbol	Parameter	Conditions	Min	Typ	Max	Units
		$V_{DIFF} = 2.5V$				
$t_{PZL}$ $t_{PZH}$	Propagation Delay ENABLE to Output	$C_L = 50 \text{ pF}$ $R_L = 1000\Omega$ $V_{DIFF} = 2.5V$		13	21	ns

**Note 1:** Absolute Maximum Ratings are those values beyond which the safety of the device cannot be guaranteed. They are not meant to imply that the device should be operated at these limits. The table of "Electrical Characteristics" provides conditions for actual device operation.

**Note 2:** Unless otherwise specified, all voltages are referenced to ground.

**Note 3:** Unless otherwise specified, Min/Max limits apply across the operating temperature range.

All typicals are given for  $V_{CC} = 5V$  and  $T_A = 25^\circ\text{C}$ .

**Note 4:** ESD Rating; HBM (1.5k $\Omega$ , 100 pF)

Inputs  $\geq 2000V$

All other pins  $\geq 1000V$

EIAJ (0 $\Omega$ , 200 pF)  $\geq 350V$

**Note 5:** Ratings apply to ambient temperature at  $25^\circ\text{C}$ . Above this temperature derate N Package 13.16 mW/ $^\circ\text{C}$ , and M Package 9.52 mW/ $^\circ\text{C}$ .

## Comparison Table of Switching Characteristics into "LS-Type" Load (Note 6)

$V_{CC} = 5V$ ,  $T_A = 25^\circ\text{C}$  (Figures 4, 5)

Symbol	Parameter	DS34C86		DS3486		Units
		Typ	Max	Typ	Max	
$t_{PHL(D)}$	Propagation Delay Time Output High to Low	17		19		ns
$t_{PLH(D)}$	Propagation Delay Time Output Low to High	19		19		ns
$t_{PLZ}$	Output Low to TRI-STATE	13		23		ns
$t_{PHZ}$	Output High to TRI-STATE	12		25		ns
$t_{PZH}$	Output TRI-STATE to High	13		18		ns
$t_{PZL}$	Output TRI-STATE to Low	13		20		ns

**Note 6:** This Table is provided for comparison purposes only. The values in this table for the DS34C86 reflect the performance of the device but are not tested or guaranteed.

## Test and Switching Waveforms

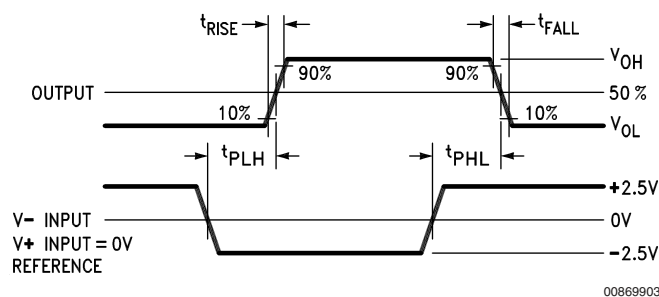
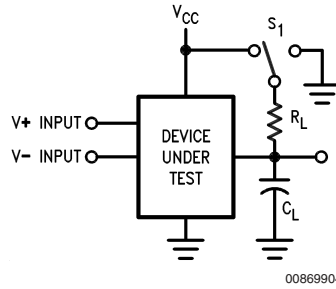

FIGURE 1. Propagation Delays

Test and Switching Waveforms (Continued)



00869904

$C_L$  Includes load and test jig capacitance.  
 $S1 = V_{CC}$  for  $t_{PZL}$ , and  $t_{PLZ}$  measurements.  
 $S1 = GND$  for  $t_{PZH}$ , and  $t_{PHZ}$  measurements.

FIGURE 2. Test Circuit for TRI-STATE Output Tests

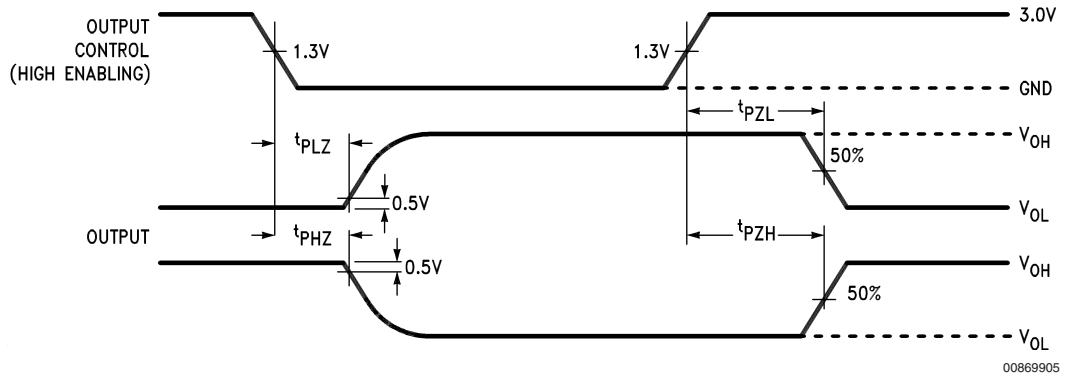

00869905

FIGURE 3. TRI-STATE Output Enable and Disable Waveforms

# AC Test Circuits and Switching Time Waveforms

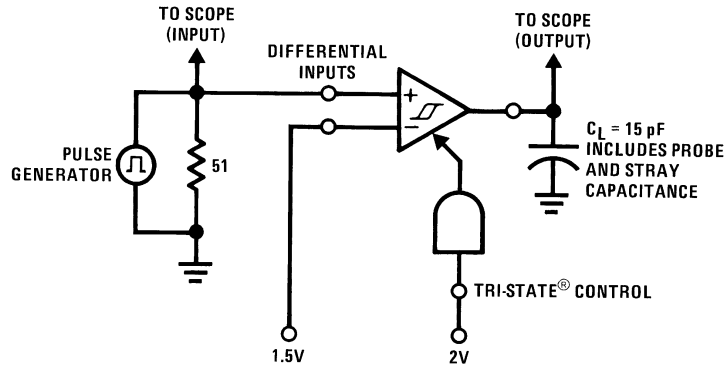

00869906

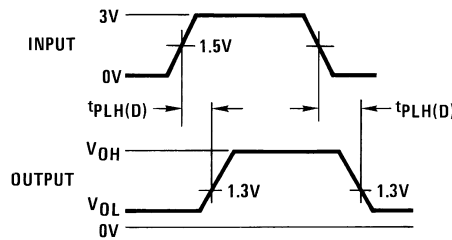

00869907

Input Pulse Characteristics:  
 $t_{TLH} = t_{THL} = 6 \text{ ns}$  (10% to 90%)  
 PRR = 1 MHz, 50% duty cycle

FIGURE 4. Propagation Delay Differential Input to Output for “LS-Type” Load

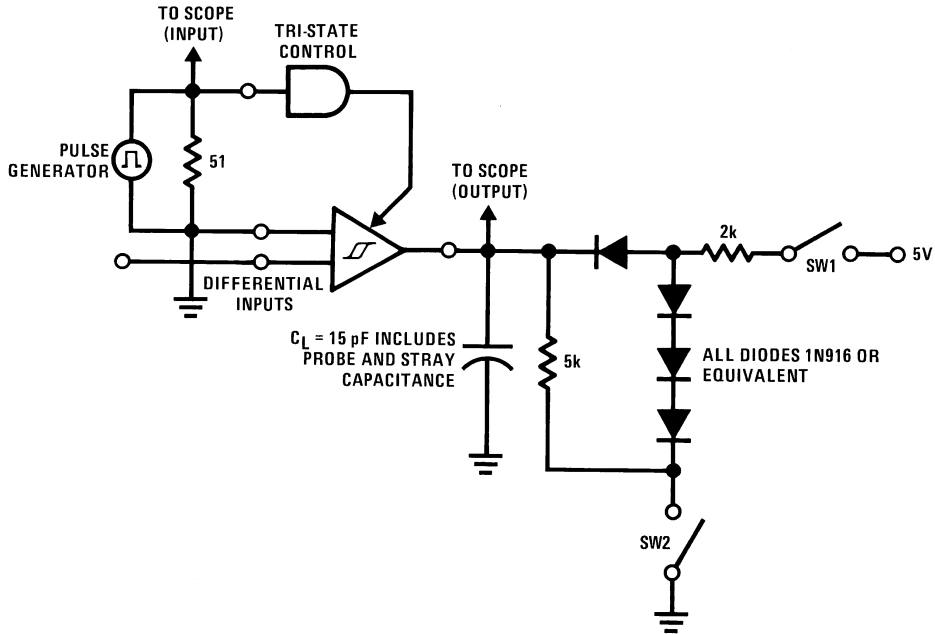

00869908

1.5V for  $t_{PHZ}$  and  $t_{PLZ}$   
 -1.5V for  $t_{PZH}$  and  $t_{PLH}$   
 Input Pulse Characteristics:  
 $t_{TLH} = t_{THL} = 6 \text{ ns}$  (10% to 90%)  
 PRR = 1 MHz, 50% duty cycle

## AC Test Circuits and Switching Time Waveforms (Continued)

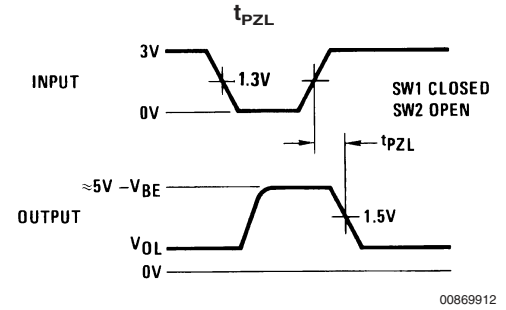
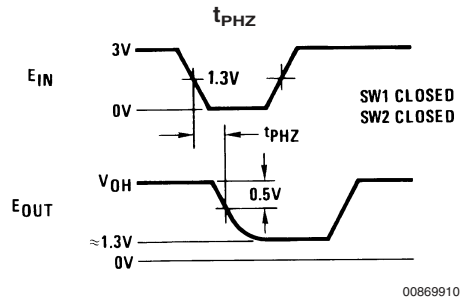
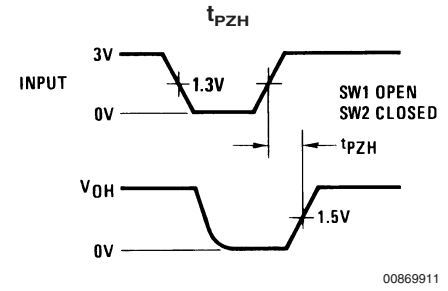
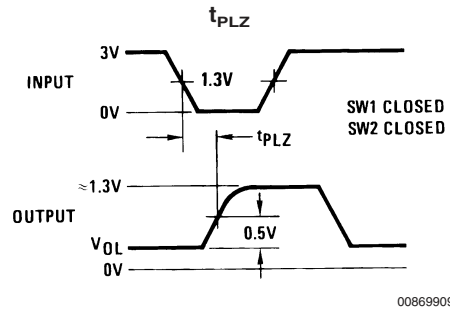
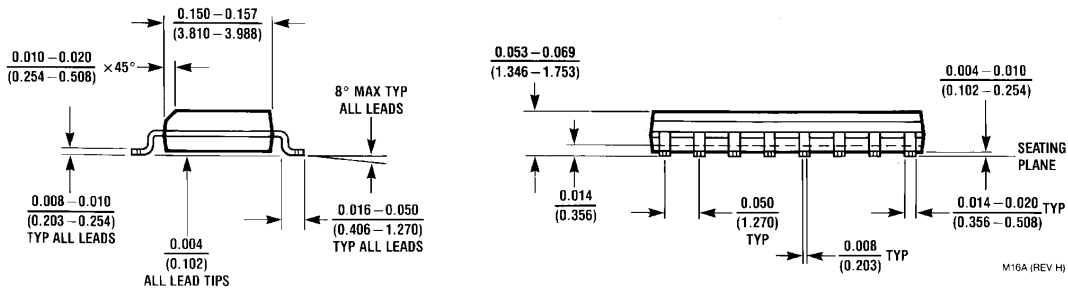
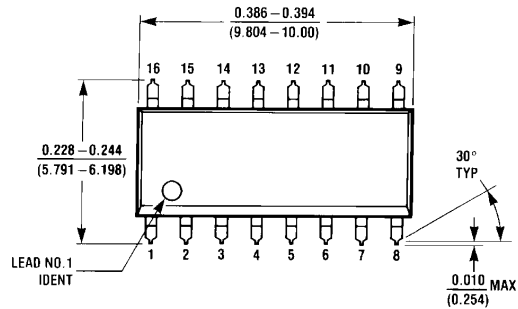
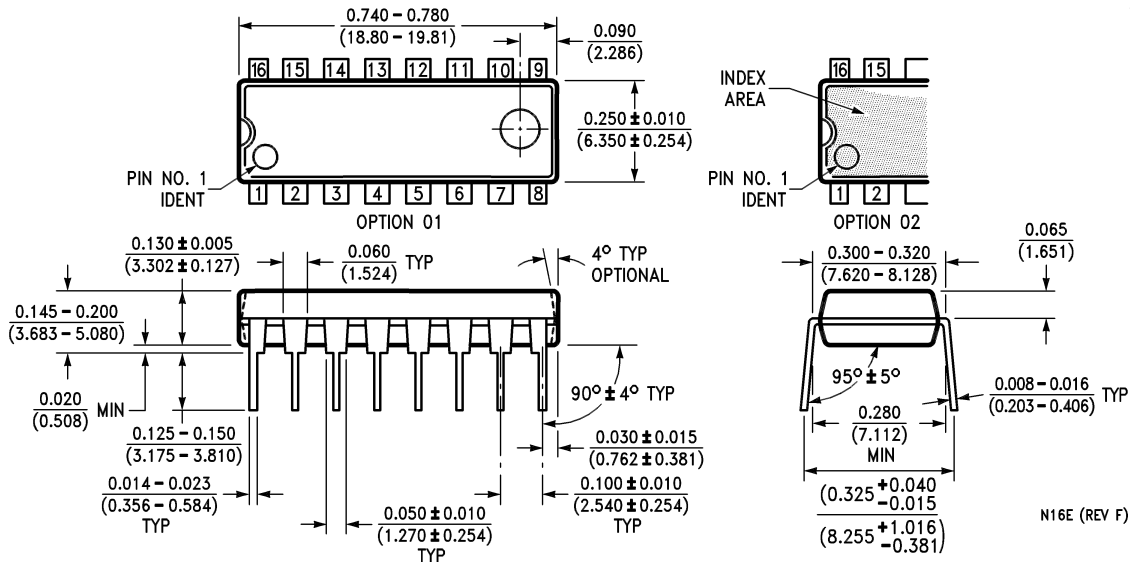

FIGURE 5. Propagation Delay TRI-STATE Control Unit to Output for "LS-Type" Load

**Physical Dimensions** inches (millimeters) unless otherwise noted



**16-Lead Molded Small Outline Package (M)**  
**Order Number DS34C86TM**  
**NS Package Number M16A**



**16-Lead Dual-In-Line Package (N)**  
**Order Number DS34C86TN**  
**NS Package Number N16E**

## Notes

### LIFE SUPPORT POLICY

NATIONAL'S PRODUCTS ARE NOT AUTHORIZED FOR USE AS CRITICAL COMPONENTS IN LIFE SUPPORT DEVICES OR SYSTEMS WITHOUT THE EXPRESS WRITTEN APPROVAL OF THE PRESIDENT AND GENERAL COUNSEL OF NATIONAL SEMICONDUCTOR CORPORATION. As used herein:

1. Life support devices or systems are devices or systems which, (a) are intended for surgical implant into the body, or (b) support or sustain life, and whose failure to perform when properly used in accordance with instructions for use provided in the labeling, can be reasonably expected to result in a significant injury to the user.
2. A critical component is any component of a life support device or system whose failure to perform can be reasonably expected to cause the failure of the life support device or system, or to affect its safety or effectiveness.

### BANNED SUBSTANCE COMPLIANCE

National Semiconductor certifies that the products and packing materials meet the provisions of the Customer Products Stewardship Specification (CSP-9-111C2) and the Banned Substances and Materials of Interest Specification (CSP-9-111S2) and contain no "Banned Substances" as defined in CSP-9-111S2.



**National Semiconductor**  
Americas Customer  
Support Center  
Email: [new.feedback@nsc.com](mailto:new.feedback@nsc.com)  
Tel: 1-800-272-9959

[www.national.com](http://www.national.com)

**National Semiconductor**  
Europe Customer Support Center  
Fax: +49 (0) 180-530 85 86  
Email: [europa.support@nsc.com](mailto:europa.support@nsc.com)  
Deutsch Tel: +49 (0) 69 9508 6208  
English Tel: +44 (0) 870 24 0 2171  
Français Tel: +33 (0) 1 41 91 8790

**National Semiconductor**  
Asia Pacific Customer  
Support Center  
Email: [ap.support@nsc.com](mailto:ap.support@nsc.com)

**National Semiconductor**  
Japan Customer Support Center  
Fax: 81-3-5639-7507  
Email: [jpn.feedback@nsc.com](mailto:jpn.feedback@nsc.com)  
Tel: 81-3-5639-7560