

DS14C88

Quad CMOS Line Driver

General Description

The DS14C88, pin-for-pin compatible to the DS1488/MC1488, is a quad line drivers designed to interface data terminal equipment (DTE) with data circuit-terminating equipment (DCE). This device translates standard TTL/CMOS logic levels to levels conforming to EIA-232-D and CCITT V.28 standards.

The device is fabricated in low threshold CMOS metal gate technology. The device provides very low power consumption compared to its bipolar equivalents: 500 μ A (DS14C88) versus 25 mA (DS1488).

The DS14C88 simplifies designs by eliminating the need for external slew rate control capacitors. Slew rate control in accordance with EIA-232D is provided on-chip, eliminating the output capacitors.

Features

- Meets EIA-232D and CCITT V.28 standards
- LOW power consumption
- Wide power supply range: $\pm 5V$ to $\pm 12V$
- Available in SOIC package

Connection Diagram

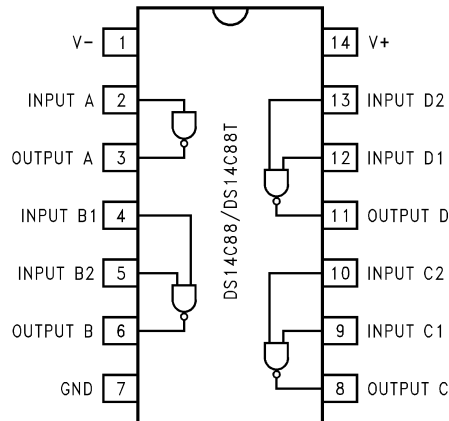

01110501

Order Number DS14C88N, or DS14C88M
See NS Package Number N14A or M14A

Absolute Maximum Ratings (Note 1)

If Military/Aerospace specified devices are required, please contact the National Semiconductor Sales Office/ Distributors for availability and specifications.

Supply Voltage	
V ⁺ Pin	+13V
V ⁻ Pin	-13V
Driver Input Voltage	(V ⁺) +0.3V to GND -0.3V
Driver Output Voltage	I(V ⁺) - V _O ≤ 30V I(V ⁻) - V _O ≤ 30V
Continuous Power Dissipation @+25°C (Note 2)	
N Package	1513 mW
M Package	1063 mW
Junction Temperature	+150°C

Lead Temperature	
(Soldering 4 seconds)	+260°C
Storage Temperature	
Range	-65°C to +150°C

This Product does not meet 2000V ESD rating. (Note 9)

Recommended Operating Conditions

	Min	Max	Units
V ⁺ Supply (GND = 0V)	+4.5	+12.6	V
V ⁻ Supply (GND = 0V)	-4.5	-12.6	V
Operating Free Air Temp. (T _A)			
DS14C88	0	+75	°C

Electrical Characteristics

Over Recommended Operating Conditions, unless otherwise specified

Symbol	Parameter	Conditions	Min	Typ	Max	Units	
I _{IL}	Maximum Low Input Current	V _{IN} = GND			+10	µA	
I _{IH}	Maximum High Input Current	V _{IN} = V ⁺	-10			µA	
V _{IL}	Low Level Input Voltage	V ⁺ ≥ +7V, V ⁻ ≤ -7V	GND		0.8	V	
		V ⁺ < +7V, V ⁻ > -7V	GND		0.6	V	
V _{IH}	High Level Input Voltage		2.0		V ⁺	V	
V _{OL}	Low Level Output Level	V _{IN} = V _{IH} R _L = 3 kΩ or 7 kΩ	V ⁺ = 4.5V, V ⁻ = -4.5V		-4.0	-3.0	V
			V ⁺ = 9V, V ⁻ = 9V		-8.0	-6.5	V
			V ⁺ = 12V, V ⁻ = -12V		-10.5	-9.0	V
V _{OH}	High Level Output Level	V _{IN} = V _{IL} R _L = 3 kΩ or 7 kΩ	V ⁺ = 4.5V, V ⁻ = -4.5V	3.0	4.0		V
			V ⁺ = 9V, V ⁻ = -9V	6.5	8.0		V
			V ⁺ = 12V, V ⁻ = -12V	9.0	10.5		V
I _{OS+}	High Level Output Short Circuit Current (Note 3)	V _{IN} = 0.8V, V _O = GND	V ⁺ = +12V, V ⁻ = -12V	-45			mA
I _{OS-}	Low Level Output Short Circuit Current (Note 3)	V _{IN} = 2.0V, V _O = GND			+45		mA
R _{OUT}	Output Resistance	V ⁺ = V ⁻ = GND = 0V -2V ≤ V _O ≤ +2V (Note 4) (Figure 1)	300				Ω
I _{CC+}	Positive Supply Current	V _{IN} = V _{ILmax} R _L = OPEN	V ⁺ = 4.5V, V ⁻ = -4.5V		10		µA
			V ⁺ = 9V, V ⁻ = -9V		30		µA
			V ⁺ = 12V, V ⁻ = -12V		60		µA
		V _{IN} = V _{IHmin} R _L = OPEN	V ⁺ = 4.5V, V ⁻ = -4.5V		50		µA
			V ⁺ = 9V, V ⁻ = -9V		300		µA
			V ⁺ = 12V, V ⁻ = -12V		500		µA
I _{CC-}	Negative Supply Current	V _{IN} = V _{ILmax} R _L = OPEN	V ⁺ = 4.5V, V ⁻ = -4.5V		-10		µA
			V ⁺ = 9V, V ⁻ = -9V		-10		µA
			V ⁺ = 12V, V ⁻ = -12V		-10		µA
		V _{IN} = V _{IHmin} R _L = OPEN	V ⁺ = 4.5V, V ⁻ = -4.5V		-30		µA
			V ⁺ = 9V, V ⁻ = -9V		-30		µA
			V ⁺ = 12V, V ⁻ = -12V		-60		µA

Switching Characteristics (Notes 5, 6)

Over Recommended Operating Conditions, unless otherwise specified (Figures 2, 3)

Symbol	Parameter	Conditions	Min	Typ	Max	Units
t_{PLH}	Propagation Delay Low to High	$V^+ = +4.5V, V^- = -4.5V$		1.5	6.0	μs
		$V^+ = +9.0V, V^- = -9.0V$		1.2	5.0	μs
		$V^+ = +12V, V^- = -12V$		1.2	4.0	μs
t_{PHL}	Propagation Delay High to Low	$V^+ = +4.5V, V^- = -4.5V$		1.5	6.0	μs
		$V^+ = +9.0V, V^- = -9.0V$		1.35	5.0	μs
		$V^+ = +12V, V^- = -12V$		1.3	4.0	μs
t_r	Rise Time (Note 7)		0.2	1.0		μs
t_f	Fall Time (Note 7)		0.2	1.0		μs
tsk	Typical Propagation Delay Skew	$V^+ = +4.5V, V^- = -4.5V$		250		ns
		$V^+ = +9.0V, V^- = -9.0V$		200		ns
		$V^+ = +12V, V^- = -12V$		150		ns
S_R	Output Slew Rate (Note 7)	$R_L = 3\text{ k}\Omega$ to $7\text{ k}\Omega$			30	$V/\mu s$
		$C_L = 15\text{ pF}$ to 2500 pF				

Note 1: "Absolute Maximum Ratings" are those values beyond which the safety of the device cannot be guaranteed. They are not meant to imply that the devices should be operated at these limits. The tables of "Electrical Characteristics" specify conditions for device operation.

Note 2: Derate N Package 12.1 mW/°C, and M Package 8.5 mW/°C above +25°C.

Note 3: I_{OS+} and I_{OS-} values are for one output at a time. If more than one output is shorted simultaneously, the device dissipation may be exceeded.

Note 4: Power supply (V^+ , V^-) and GND pins are connected to ground for the Output Resistance Test (R_O).

Note 5: AC input test waveforms for test purposes: $t_r = t_f \leq 20\text{ ns}$, $V_{IH} = 2V$, $V_{IL} = 0.8V$ ($0.6V$ at $V^+ = 4.5V$, $V^- = -4.5V$)

Note 6: Input rise and fall times must not exceed $5\text{ }\mu s$.

Note 7: The output slew rate, rise time, and fall time are measured from the $+3.0V$ to the $-3.0V$ level on the output waveform.

Note 8: C_L include jig and probe capacitances.

Note 9: ESD Rating (HBM, $1.5\text{ k}\Omega$, 100 pF) $\geq 1.0\text{ kV}$.

Parameter Measure Information

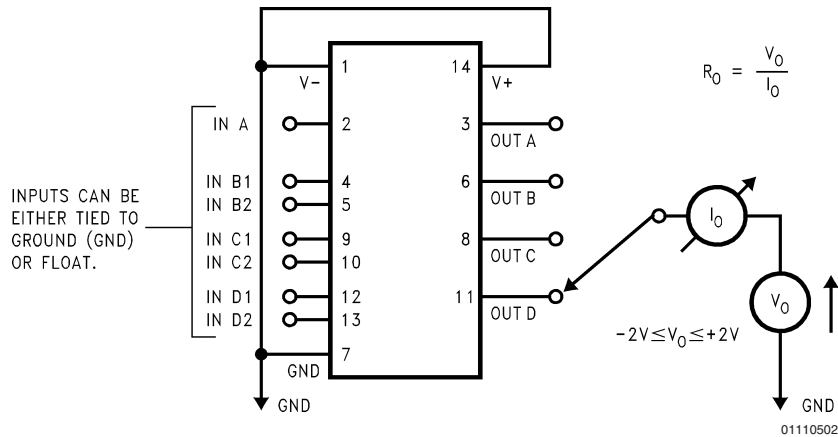

FIGURE 1. Output Resistance Test Circuit (Power-Off)

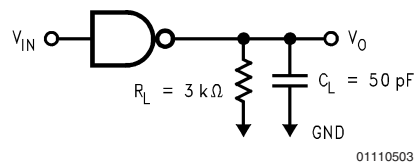

FIGURE 2. Driver Load Circuit (Note 8)

Parameter Measure Information (Continued)

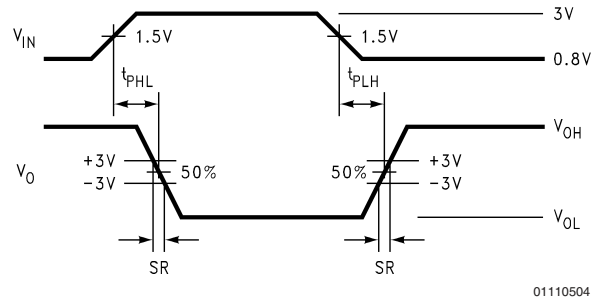

FIGURE 3. Driver Switching Waveform

Typical Application Information

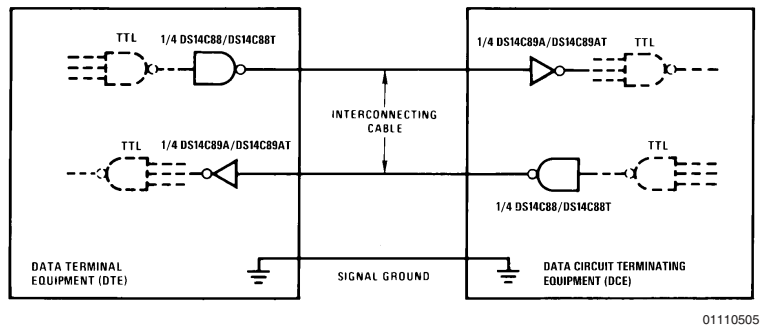
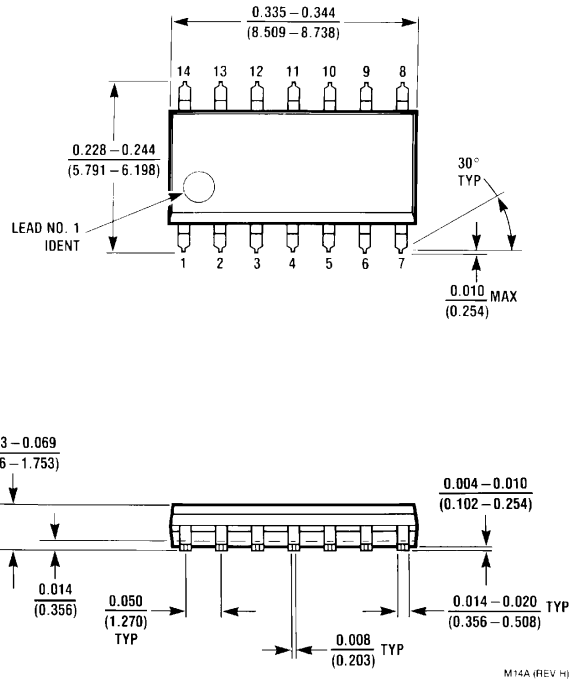

FIGURE 4. EIA-232D Data Transmission

Physical Dimensions inches (millimeters)

unless otherwise noted



Order Number DS14C88M or DS14C88TM
NS Package Number M14A

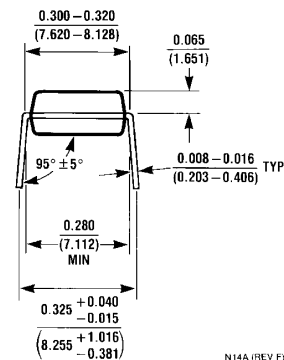
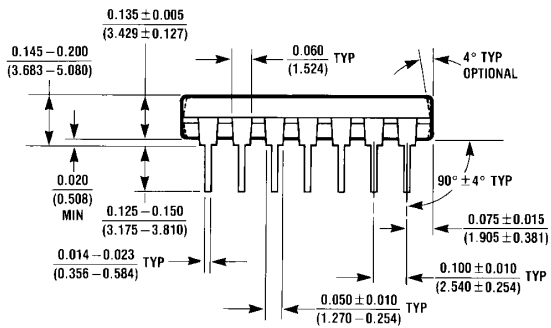
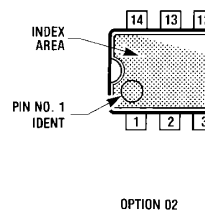
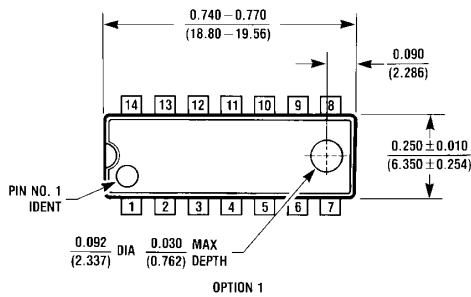

Order Number DS14C88N or DS14C88TN
NS Package Number N14A

Notes

LIFE SUPPORT POLICY

NATIONAL'S PRODUCTS ARE NOT AUTHORIZED FOR USE AS CRITICAL COMPONENTS IN LIFE SUPPORT DEVICES OR SYSTEMS WITHOUT THE EXPRESS WRITTEN APPROVAL OF THE PRESIDENT AND GENERAL COUNSEL OF NATIONAL SEMICONDUCTOR CORPORATION. As used herein:

1. Life support devices or systems are devices or systems which, (a) are intended for surgical implant into the body, or (b) support or sustain life, and whose failure to perform when properly used in accordance with instructions for use provided in the labeling, can be reasonably expected to result in a significant injury to the user.
2. A critical component is any component of a life support device or system whose failure to perform can be reasonably expected to cause the failure of the life support device or system, or to affect its safety or effectiveness.

BANNED SUBSTANCE COMPLIANCE

National Semiconductor certifies that the products and packing materials meet the provisions of the Customer Products Stewardship Specification (CSP-9-111C2) and the Banned Substances and Materials of Interest Specification (CSP-9-111S2) and contain no "Banned Substances" as defined in CSP-9-111S2.



National Semiconductor
Americas Customer
Support Center
Email: new.feedback@nsc.com
Tel: 1-800-272-9959

www.national.com

National Semiconductor
Europe Customer Support Center
Fax: +49 (0) 180-530 85 86
Email: europe.support@nsc.com
Deutsch Tel: +49 (0) 69 9508 6208
English Tel: +44 (0) 870 24 0 2171
Français Tel: +33 (0) 1 41 91 8790

National Semiconductor
Asia Pacific Customer
Support Center
Email: ap.support@nsc.com

National Semiconductor
Japan Customer Support Center
Fax: 81-3-5639-7507
Email: jpn.feedback@nsc.com
Tel: 81-3-5639-7560