

## 2-Bit Level Shifting Buffer/Transceiver with Configurable Dual Supply Voltage

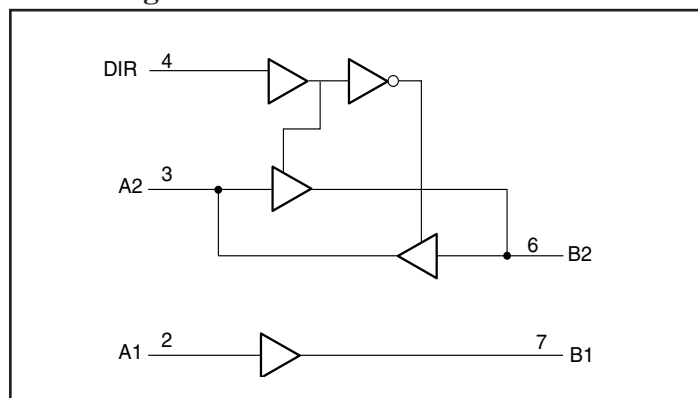
### Features

- Operation Voltage:  $1.65V \leq V_{DDA} \leq 3.6V$   
 $2.3V \leq V_{DDB} \leq 5.5V$   
 $V_{DDA} \leq V_{DDB}$
- High Speed:  $t_{pd} = 5ns$  typical into  $30pF @ 3V V_{DD}$
- Power down high-impedance inputs and outputs
- High output drive:  $\pm 12mA$  at  $3V V_{DDA}/V_{DDB}$   
 $\pm 24mA$  at  $5V V_{DDB}$
- Industrial operation at  $-40^{\circ}C$  to  $+85^{\circ}C$
- Packaging (Pb-free & Green available):
  - 8-pin MSOP (U)
  - 12-pin TDFN (ZE)

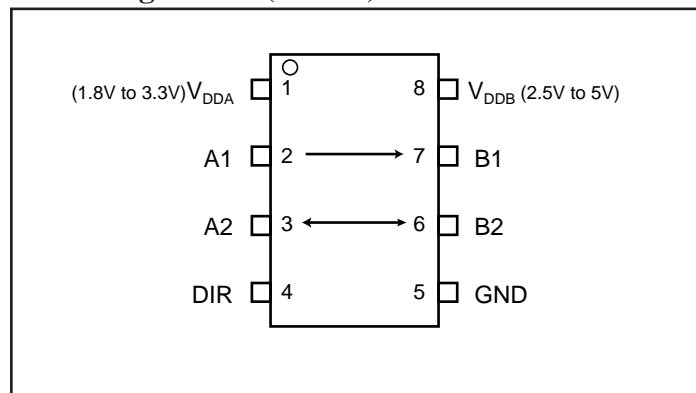
### Description

Pericom Semiconductor's PI74STX2G4245, a 2-bit noninverting buffer/transceiver, contains two separate supply rails: A port ( $V_{DDA}$ ), set to operate from 1.8V to 3.3V; B port ( $V_{DDB}$ ), set to operate from 2.5V to 5V. The A1 to B1 translation is configured as an unidirectional buffer; the translation between A2 and B2 is bidirectional and its direction is controlled by the DIR pin. The DIR pin is supplied by  $V_{DDB}$ .

### Block Diagram



### Pin Configuration (MSOP)



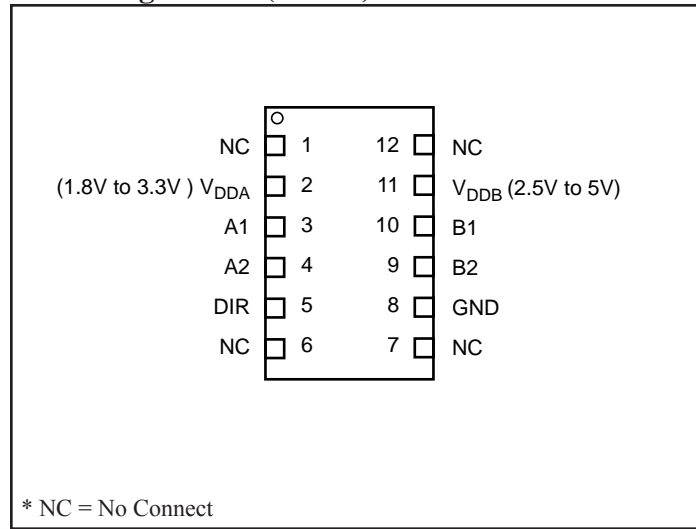
### Function Table

Input		Output
DIR	DATA	
L	B2	A2
H	A2	B2
X	A1	B1

### Pin Description

Pin Name	Description
DIR	Direction Control
A1	Data Input
B1	Data Output
A2, B2	Data Input/Output
$V_{DDA}, V_{DDB}$	Power Supply

### Pin Configuration (TDFN)



### Maximum Ratings

(Absolute maximum ratings over operating free-air temperature range from  $V_{DDB}$  at 2.5V &  $V_{DDA}$  at 1.2V, unless otherwise noted)

Supply voltage range: $V_{DDA}$ .....	-0.5V to +6V	DC Input Diode Current, $I_{IK}$ ( $V_O < 0$ ) .....	-50mA
$V_{DDB}$ .....	-0.5V to +6V	DC Output Diode Current, $I_{OK}$ ( $V_O < 0$ ) .....	-50mA
Input Voltage Range, $V_I$ :		DC Output Current, ( $I_{OUT}$ ) .....	$\pm 50$ mA
Input A1 <sup>(1)</sup> .....	-0.5V to +6V	DC $V_{CC}$ or GND Current ( $I_{CC}/I_{GND}$ ).....	$\pm 100$ mA
I/O A2 <sup>(1,2)</sup> .....	-0.5V to $V_{DDA}+0.5V$	Storage temperature range, $T_{STG}$ .....	-65°C to 150°C
I/O B2 <sup>(1,2)</sup> .....	-0.5V to $V_{DDB}+0.5V$	Junction Lead Temperature ( $I_{OS}$ ) .....	260°C
Output Voltage Range, $V_O$		Power Dissipation: MSOP.....	200mW
Output B1 <sup>(1,2)</sup> ...	-0.5V to $V_{DDB} +0.5V$		

#### Notes:

Stresses greater than those listed under MAXIMUM RATINGS may cause permanent damage to the device. This is a stress rating only and functional operation of the device at these or any other conditions above those indicated in the operational sections of this specification is not implied. Exposure to absolute maximum rating conditions for extended periods may affect reliability.

1. The input negative voltage and output voltage ratings may be exceeded if the input and output current ratings are observed.
2. This value is limited to 6V.

### Recommended Operating Conditions for A Port ( $V_{DDA}$ )<sup>(1)</sup>

Parameter	Description	Test Conditions	Min.	Max.	Units
$V_{DDA}$	Supply Voltage		1.65	3.6	V
$V_{IH}$	High-level input voltage	$V_{DDA} = 1.65V$ to 1.95V	$0.7 \times V_{DDA}$		
		$V_{DDA} = 2.3V$ to 3.6V	$0.7 \times V_{DDA}$		
$V_{IL}$	Low-level input voltage	$V_{DDA} = 1.65$ to 1.95V		$0.3 \times V_{DDA}$	
		$V_{DDA} = 2.3V$ to 3.6V		$0.3 \times V_{DDA}$	
$V_{IA}$	Input Voltage		0	$V_{DDA}$	
$V_{OA}$	Output Voltage		0	$V_{DDA}$	
$I_{OH}$	High-level Output Current	$V_{DDA} = 1.65$ V to 1.95V		-4	mA
		$V_{DDA} = 2.3V$ to 2.7V		-8	
		$V_{DDA} = 3V$ to 3.6V		-12	
$I_{OL}$	Low-level Output Current	$V_{DDA} = 1.65V$ to 1.95V		4	
		$V_{DDA} = 2.3V$ to 2.7V		8	
		$V_{DDA} = 3V$ to 3.6V		12	
$\Delta t/\Delta V$	Input transition rise or fall rate	$V_{DDA} = 1.65V$ to 1.95V		20	ns/V
		$V_{DDA} = 2.3V$ to 3.6V		10	
$T_A$	Operation free-air temperature		-40	85	°C

#### Notes:

1. To ensure proper device operation, all unused inputs must be held at  $V_{DDA}$  or GND.

**Recommended Operating Conditions for B Port (  $V_{DDB}$  )<sup>(1)</sup>**

Parameters	Description	Test Conditions	Min.	Max.	Units
$V_{DDB}$	Supply Voltage		2.3	5.5	V
$V_{IH}$	High-level input voltage	Data Inputs	$V_{DDB} = 2.3V$ to $5.5V$	$0.7 \times V_{DDB}$	
		DIR pin			
$V_{IL}$	Low-level input voltage	Data Inputs	$V_{DDB} = 2.3V$ to $5.5V$	$0.3 \times V_{DDB}$	
		DIR pin			
$V_{IB}$	Input Voltage		0	$V_{DDB}$	
$V_{OB}$	Output Voltage		0	$V_{DDB}$	
$I_{OH}$	High-level Output Current	$V_{DDB} = 2.3 V$ to $2.7V$		-8	mA
		$V_{DDB} = 3V$ to $3.6V$		-12	
		$V_{DDB} = 4.5V$ to $5.5V$		-24	
$I_{OL}$	Low-level Output Current	$V_{DDB} = 2.3V$ to $2.7V$		8	
		$V_{DDB} = 3V$ to $3.6V$		12	
		$V_{DDB} = 4.5V$ to $5.5V$		24	
$\Delta t/\Delta V$	Input transition rise or fall rate	$V_{DDB} = 2.3V$ to $5.5V$		10	m/V
$T_A$	Operation free-air temperature		-40	85	°C

**Notes:**

- To ensure proper device operation, all unused inputs must be held at  $V_{DDB}$  or GND.

**Electrical Characteristics** (Over recommended operating free-air temperature range)

Parameters		Test Conditions	V <sub>DDA</sub> <sup>(1)</sup>	V <sub>DDB</sub> <sup>(1)</sup>	Min.	Typ. <sup>(2)</sup>	Max.	Units	
V <sub>OHA</sub> (B to A)		I <sub>OH</sub> = -100uA	1.65V to 3.6V	2.3V ≤ V <sub>DDB</sub> ≤ 5.5V and V <sub>DDB</sub> ≥ V <sub>DDA</sub>	V <sub>DDB</sub> -0.1			V	
		I <sub>OH</sub> = -4mA	1.65V		1.3				
		I <sub>OH</sub> = -8mA	2.3V		1.8				
		I <sub>OH</sub> = -12mA	3.0V		2.4				
V <sub>OLA</sub> (B to A)		I <sub>OH</sub> = 100uA	1.65V to 3.6V						0.1
		I <sub>OH</sub> = 4mA	1.65V						0.24
		I <sub>OH</sub> = 8mA	2.3V						0.3
		I <sub>OH</sub> = 12mA	3.0V						0.4
V <sub>OHB</sub> (A to B)		I <sub>OH</sub> = -100uA	1.65V ≤ V <sub>DDA</sub> ≤ 3.6V and V <sub>DDB</sub> ≥ V <sub>DDA</sub>	2.3V to 5.5V	V <sub>DDB</sub> -0.1				
		I <sub>OH</sub> = -8mA		2.3V	1.8				
		I <sub>OH</sub> = -12mA		3.0V	2.4				
		I <sub>OH</sub> = -24mA		4.5V	3.8				
V <sub>OLB</sub> (A to B)		I <sub>OH</sub> = 100uA			2.3V to 5.5V			0.1	
		I <sub>OH</sub> = 8mA			2.3V			0.3	
		I <sub>OH</sub> = 12mA			3.0V			0.4	
		I <sub>OH</sub> = 24mA			4.5V			0.55	
I <sub>I</sub> <sup>(3)</sup>	V <sub>I</sub> = V <sub>DDA</sub> /V <sub>DDB</sub> or GND	1.65V to 3.6V and V <sub>DDB</sub> ≥ V <sub>DDA</sub>	2.3V to 5.5V and V <sub>DDB</sub> ≥ V <sub>DDA</sub>				±5		
I <sub>OFF</sub>	V <sub>I</sub> or V <sub>O</sub> = V <sub>DDB</sub> or GND	0V	0 to 5.5V				±10		
	V <sub>I</sub> or V <sub>O</sub> = V <sub>DDA</sub> or GND	0 to 3.6V	0V				±10		
I <sub>CCA</sub>	V <sub>I</sub> = V <sub>DDA</sub> or GND, I <sub>O</sub> = 0	1.65V to 3.6V and V <sub>DDB</sub> ≥ V <sub>DDA</sub>	2.3 to 5.5V and V <sub>DDB</sub> ≥ V <sub>DDA</sub>				10		
I <sub>CCB</sub>	V <sub>I</sub> = V <sub>DDB</sub> or GND, I <sub>O</sub> = 0							10	
C <sub>I</sub>	A1, DIR	V <sub>I</sub> = V <sub>DDA</sub> or GND	1.8V	3.3V		4.5			
C <sub>O</sub>	B1	V <sub>O</sub> = V <sub>DDB</sub> or GND	1.8V	3.3V		4.5			
C <sub>IO</sub>	A2, B2	V <sub>I</sub> or V <sub>O</sub> = V <sub>DDA</sub> /V <sub>DDB</sub> or GND	1.8V	3.3V		6.0			

**Notes:**

- When 1.65 ≤ V<sub>DDA</sub> ≤ 1.95V, V<sub>DDB</sub> can not be greater than 3.6V
- All Typical values are at T<sub>A</sub> = 25°C
- For I/O ports, the parameter I<sub>I</sub> includes the output leakage current.

**Switching Characteristics for  $V_{DDA} = 1.8V \pm 0.15V$**

(Over recommended operating free-air temperature range, see figure 1)

Parameter	From (Input)	To (Output)	$V_{DDB} = 2.5V \pm 0.2V$		$V_{DDB} = 3.3V \pm 0.3V$		Units
			Min.	Max.	Min.	Max.	
$t_{PHL}$	A	B	1.0	8	1.0	8	ns
$t_{PLH}$			1.0	8	1.0	8	
$t_{PHL}$	B	A	1.0	7	1.0	7	
$t_{PLH}$			1.0	7	1.0	7	
$t_{SK(O)}$				1.5		1	

**Switching Characteristics for  $V_{DDA} = 2.5V \pm 0.2V$**

(Over recommended operating free-air temperature range, see figure 1)

Parameter	From (Input)	To (Output)	$V_{DDB} = 2.5V \pm 0.2V$		$V_{DDB} = 3.3V \pm 0.3V$		$V_{DDB} = 5V \pm 0.5V$		Units
			Min.	Max.	Min.	Max.	Min.	Max.	
$t_{PHL}$	A	B	1.0	7	1.0	6.5	1.0	6	ns
$t_{PLH}$			1.0	7	1.0	6.5	1.0	6	
$t_{PHL}$	B	A	1.0	6	1.0	6	1.0	5	
$t_{PLH}$			1.0	6	1.0	6	1.0	5	
$t_{SK(O)}$				1.5		1		1	

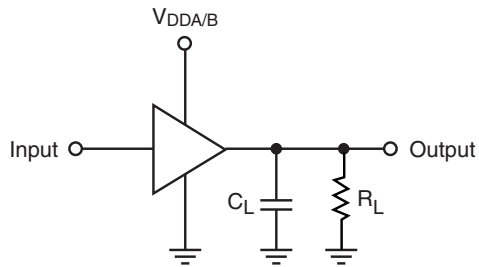
**Switching Characteristics for  $V_{DDA} = 3.3V \pm 0.3V$**

(Over recommended operating free-air temperature range, see figure 1)

Parameter	From (Input)	To (Output)	$V_{DDB} = 3.3V \pm 0.3V$		$V_{DDB} = 5V \pm 0.5V$		Units
			Min.	Max.	Min.	Max.	
$t_{PHL}$	A	B	1.0	5	1.0	5	ns
$t_{PLH}$			1.0	5	1.0	5	
$t_{PHL}$	B	A	1.0	5	1.0	5	
$t_{PLH}$			1.0	5	1.0	5	
$t_{SK(O)}$				1		1	

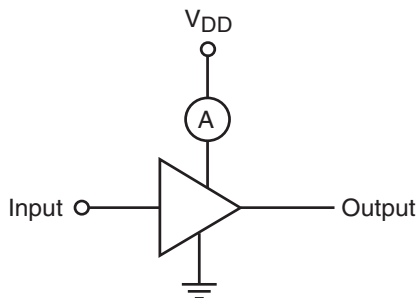
### AC Loading and Waveforms

V <sub>DDA/B</sub>	C <sub>L</sub>	R <sub>L</sub>
1.8 ± 0.15V	15pF	1KΩ
2.5V ± 0.2V	15pF	500Ω
3.0V to 3.6V	30pF	500Ω
5V ± 0.5V	50pF	500Ω



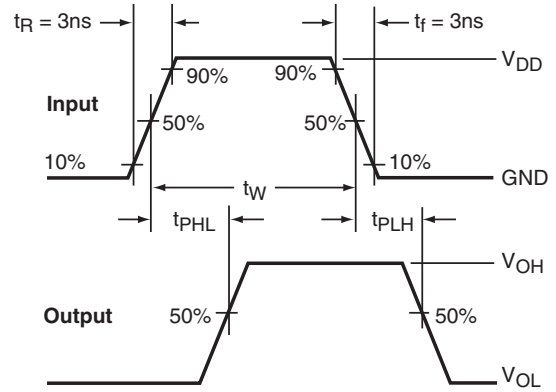
C<sub>L</sub> includes load and stray capacitance  
Input PRR = 1.0 MHz; t<sub>W</sub> = 500ns

**Figure 1. AC Test Circuit**



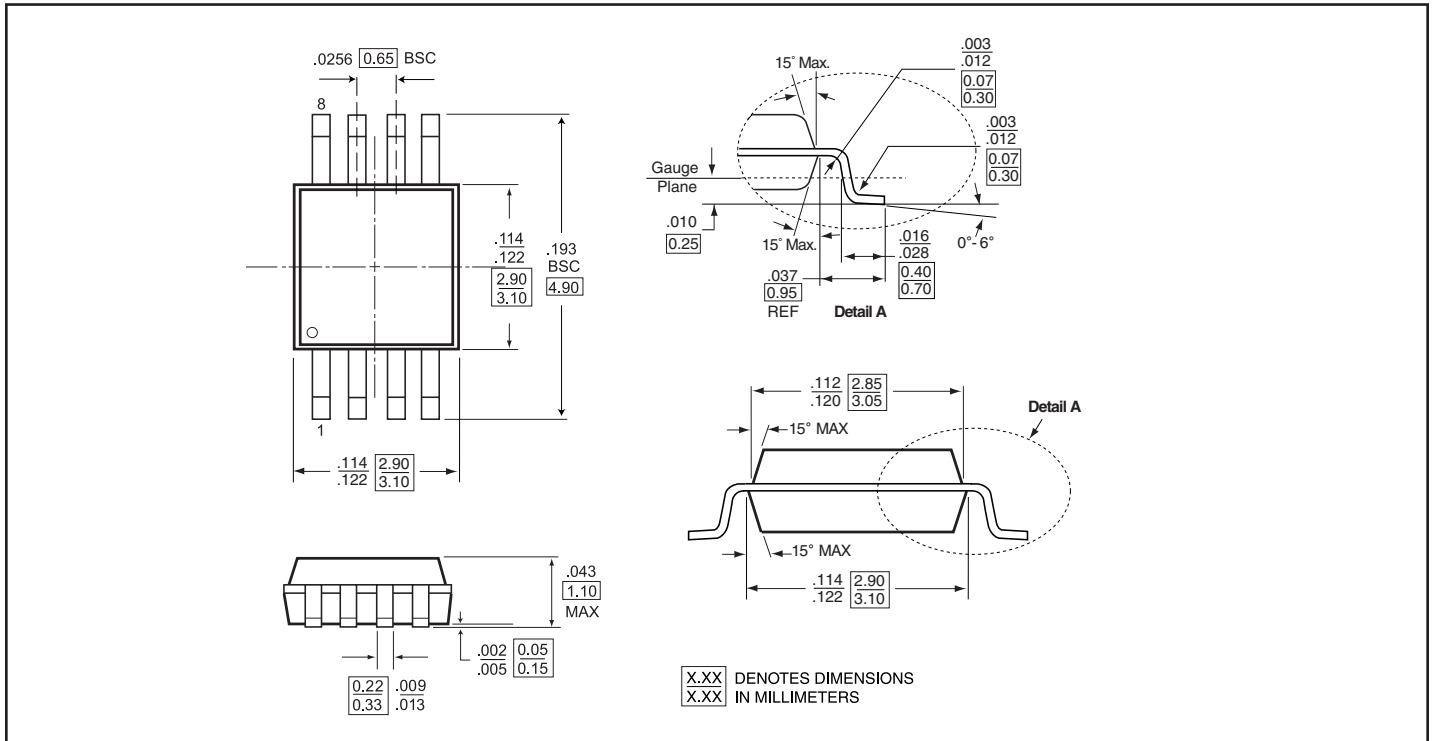
Input = AC Waveform; t<sub>r</sub> = t<sub>f</sub> = 1.8ns;  
PRR = 10 MHz; Duty Cycle = 50%

**Figure 2. ICCD Test Circuit**

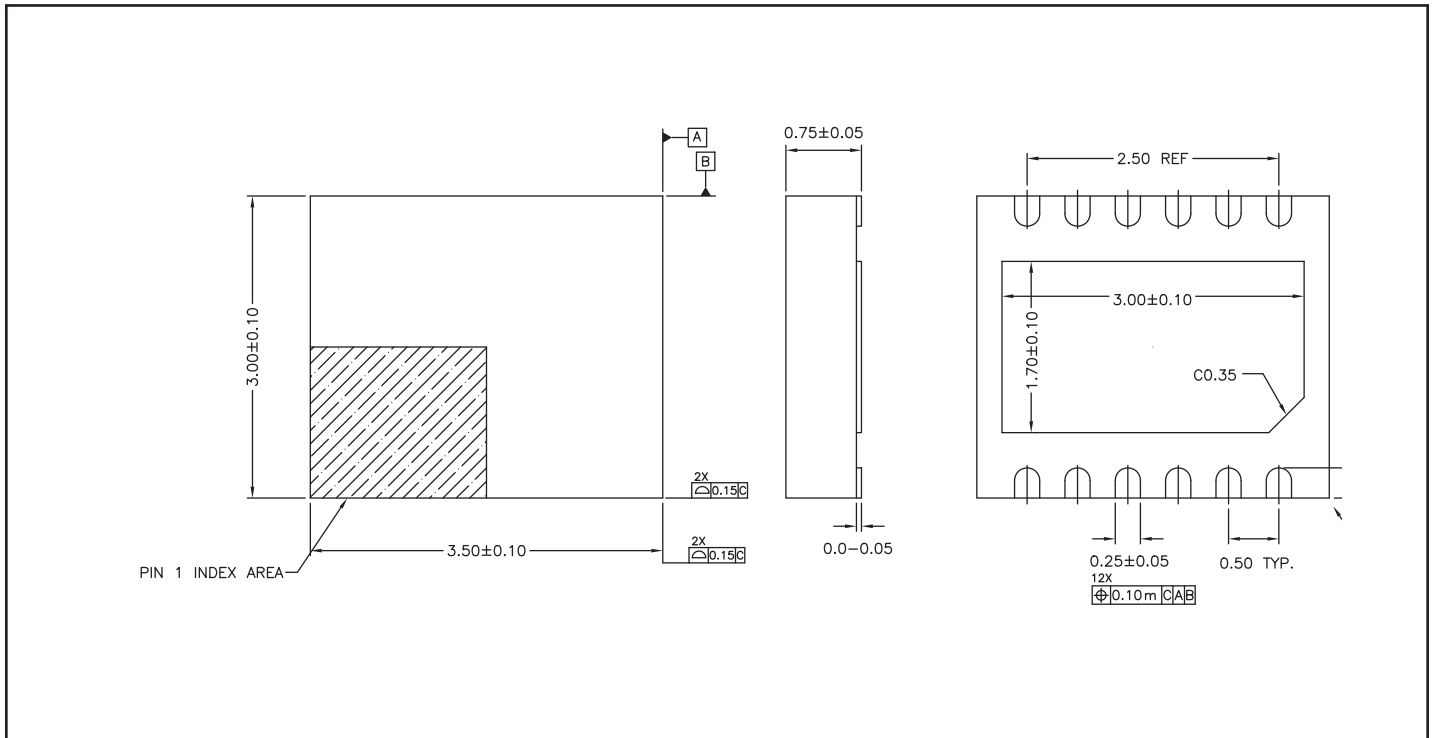


**Figure 3. AC Waveforms**

**Packaging Mechanical: 8-Pin MSOP (U)**



**Packaging Mechanical: 12-pin TDFN (ZE)**



### Ordering Information

Ordering Code	Package Code	Package Type	Package Top Marking
PI74STX2G4245UEX	U	Pb-free & Green, 8-pin MSOP	STX2G4245E
PI74STX2G4245ZEEX	ZE	Pb-free & Green, 12-pin TDFN	$\bar{D}E$

**Notes:**

- Thermal characteristics can be found on the company web site at [www.pericom.com/packaging/](http://www.pericom.com/packaging/)
- E = Pb-free & Green
- X suffix = Tape/Reel