

DP83840A 10/100 Mb/s Ethernet Physical Layer

General Description

The DP83840A is a Physical Layer device for Ethernet 10BASE-T and 100BASE-X using category 5 Unshielded, Type 1 Shielded and Fiber Optic cables.

This VLSI device is designed for easy implementation of 10/100 Mb/s Ethernet LANs. It interfaces to the PMD sub-layer through National Semiconductor's DP83223 Twisted Pair Transceiver, and to the MAC layer through a Media Independent Interface (MII), ensuring interoperability between products from different vendors.

The DP83840A is designed with National Semiconductor's BiCMOS process. Its system architecture is based on the integration of several of National Semiconductor's industry proven core technologies:

- 10BASE-T ENDEC/Transceiver module to provide the 10 Mb/s IEEE 802.3 functions
- Clock Recovery/Generator Modules from National Semiconductor's leading FDDI product
- FDDI Stream Cipher (Cyclone)
- 100BASE-X physical coding sub-layer (PCS) and control logic that integrate the core modules into a dual speed Ethernet physical layer controller

Features

- IEEE 802.3 10BASE-T compatible--ENDEC and UTP/STP transceivers and filters built-in
- IEEE 802.3u 100BASE-X compatible--support for 2 pair Category 5 UTP (100m), Type 1 STP and Fiber Optic Transceivers--Connects directly to the DP83223 Twisted Pair Transceiver
- ANSI X3T12 TP-PMD compatible
- IEEE 802.3u Auto-Negotiation for automatic speed selection
- IEEE 802.3u compatible Media Independent Interface (MII) with Serial Management Interface
- Integrated high performance 100 Mb/s clock recovery circuitry requiring no external filters
- Full Duplex support for 10 and 100 Mb/s
- MII Serial 10 Mb/s output mode
- Fully configurable node and repeater modes--allows operation in either application
- Programmable loopback modes for easy system diagnostics
- Flexible LED support
- IEEE 1149.1 Standard Test Access Port and Boundary-Scan compatible
- Small footprint 100-pin PQFP package
- Individualized scrambler seed for multi-PHY applications

System Diagram

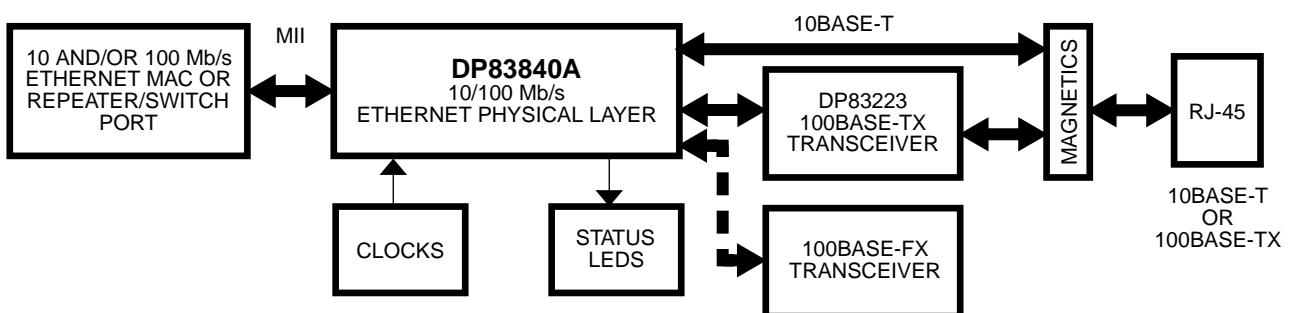

Block Diagram

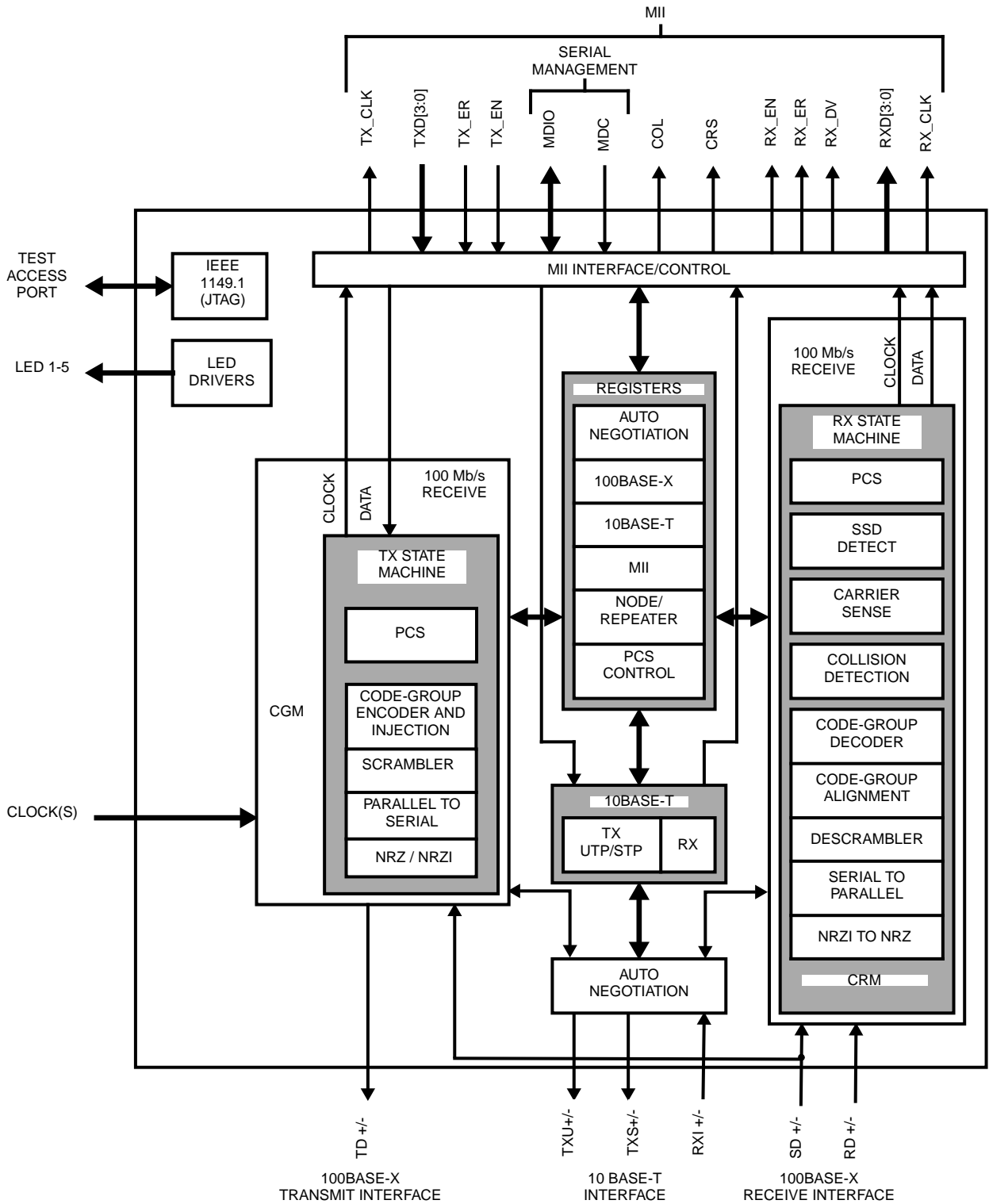

Table of Contents

GENERAL DESCRIPTION

FEATURES

SYSTEM DIAGRAM

BLOCK DIAGRAM

REVISION HISTORY

TABLE OF CONTENTS

1.0 PIN CONNECTION DIAGRAM

2.0 PIN DESCRIPTION

- 2.1 MII Interface
- 2.2 100 Mb/s Serial PMD Interface
- 2.3 10 Mb/s Interface
- 2.4 Clock Interface
- 2.5 Device Configuration Interface
- 2.6 LED Interface
- 2.7 IEEE 1149.1 Interface
- 2.8 PHY Address Interface
- 2.9 Miscellaneous
- 2.10 Power and Ground Pins
- 2.11 Special Connect Pins
- 2.12

3.0 FUNCTIONAL DESCRIPTION

- 3.1 PCS Control
- 3.2 MII Serial Management Register Access
- 3.3 100BASE-X Transmitter
- 3.4 100BASE-X Receiver
- 3.5 Clock Generation Module
- 3.6 100 Mb/s Clock Recovery Module
- 3.7 10BASE-T Transceiver Module
- 3.8 IEEE 1149.1 Controller
- 3.9 IEEE 802.3u Auto-Negotiation
- 3.10 Reset Operation
- 3.11 Loopback Operation
- 3.12 Alternative 100BASE-X Operation
- 3.13 Low Power Mode

4.0 Registers

- 4.1 Key to Defaults
- 4.2 Basic Mode Control Register
- 4.3 Basic Mode Status Register
- 4.4 PHY Identifier Register #1
- 4.5 PHY Identifier Register #2
- 4.6 Auto-Negotiation Advertisement Register
- 4.7 Auto-Negotiation Link Partner Ability Register
- 4.8 Auto-Negotiation Expansion Register
- 4.9 Disconnect Counter Register
- 4.10 False Carrier Sense Counter Register

- 4.11 Receive Error Counter Register
- 4.12 Silicon Revision Register
- 4.13 PCS Sub-Layer Configuration Register
- 4.14 Loopback, Bypass, and Receive Error Mask Register
- 4.15 PHY Address Register
- 4.16 10BASE-T Status Register
- 4.17 10BASE-T Configuration Register

5.0 DP83840A APPLICATION

- 5.1 Typical Board Level Application
- 5.2 Layout Recommendations
- 5.3 Plane Partitioning
- 5.4 Power and Ground Filtering

6.0 Hardware User Information

- 6.1 Jabber/Timeout
- 6.2 Link Timer
- 6.3 Link LED, Link Status Bit
- 6.4 PHYAD[3] and Speed_100
- 6.5 Collision De-Assertion Time
- 6.6 Synchronization of Idle
- 6.7 100 Mb/s Differential Output Voltage
- 6.8 10Base-T Transmit Differential Output Impedance
- 6.9 Low Power Mode
- 6.10 Software Reset
- 6.11 Receive Error Counter
- 6.12 Auto-Negotiation Test Compliancy

7.0 Software User information

- 7.1 100Mb/s Full Duplex Log-On
- 7.2 Auto-Negotiation to Link Sending 100Mb/s Scrambled Idles
- 7.3 840A Auto-Negotiating to Legacy Devices
- 7.4 HBE Disable in 10Mb/s Repeater Mode
- 7.5 CRS Glitching in 10Mb/s Repeater Mode

8.0 ELECTRICAL SPECIFICATIONS

- 8.1 Ratings and Operating Conditions
- 8.2 DC Specifications
- 8.3 Clock Timing
- 8.4 MII Serial Management AC Timing
- 8.5 100 Mb/s AC Timing
- 8.6 10 Mb/s AC Timing
- 8.7 Fast Link Pulse Timing
- 8.8 Clock Recovery Module Timing
- 8.9 Reset Timing
- 8.10 Loopback Timing
- 8.11 PHY Isolation Timing

9.0 Package Dimensions

2.0 Pin Description

The DP83840A pins are classified into the following interface categories (each interface is described in the sections that follow):

MII INTERFACE

100 Mb/s SERIAL PMD INTERFACE

10 Mb/s INTERFACE

CLOCK INTERFACE

DEVICE CONFIGURATION INTERFACE

LED INTERFACE

IEEE 1149.1 INTERFACE

PHY ADDRESS INTERFACE

MISCELLANEOUS PINS

POWER AND GROUND PINS

SPECIAL CONNECT PINS

2.1 MII INTERFACE

Signal Name	Type	Pin #	Description
TX_CLK	O, Z	82	TRANSMIT CLOCK: Transmit clock output from the DP83840A: 25 MHz nibble transmit clock derived from Clock Generator Module's (CGM) PLL in 100BASE-TX mode 2.5 MHz transmit clock in 10BASE-T nibble mode 10 MHz transmit clock in 10BASE-T serial mode
TXD[3] TXD[2] TXD[1] TXD[0]	I, J	75 76 77 78	TRANSMIT DATA: Transmit data MII input pins that accept nibble data during normal nibble-wide MII operation at either 2.5 MHz (10BASE-T mode) or 25MHz (100BASE-X mode) In 10 Mb/s serial mode, the TXD[0] pin is used as the serial data input pin. TXD[3:1] are ignored.
TX_EN	I, J	74	TRANSMIT ENABLE: Active high input indicates the presence of valid nibble data on TXD[3:0] for both 100 Mb/s or 10 Mb/s nibble mode. In 10 Mb/s serial mode, active high indicates the presence of valid 10 Mb/s data on TXD[0].
TX_ER (TXD[4])	I, J	73	TRANSMIT ERROR: In 100 Mb/s mode, when this signal is high and TX_EN is active the HALT symbol is substituted for the actual data nibble. In 10 Mb/s mode, this input is ignored. In encoder bypass mode (BP_4B5B or BP_ALIGN), TX_ER becomes the TXD [4] pin, the new MSB for the transmit 5-bit data word.
MDC	I, J	72	MANAGEMENT DATA CLOCK: Synchronous clock to the MDIO management data input/output serial interface which may be asynchronous to transmit and receive clocks. The maximum clock rate is 2.5 MHz. There is no minimum clock rate.
MDIO	I/O, Z, J	67	MANAGEMENT DATA I/O: Bi-directional management instruction/data signal that may be sourced by the station management entity or the PHY. This pin requires a 1.5k Ω pullup resistor.

I = TTL/CMOS input

O = TTL/CMOS output

Z = TRI-STATE output

J = IEEE 1149.1 pin

2.0 Pin Description (Continued)

2.1 MII INTERFACE

CRS (PHYAD[2])	I/O, Z, J	66	<p>CARRIER SENSE: This pin is asserted high to indicate the presence of carrier due to receive or transmit activities in 10BASE-T or 100BASE-X Half Duplex modes.</p> <p>In Repeater or Full Duplex mode a logic 1 indicates presence of carrier due only to receive activity.</p> <p>This is also the PHY address sensing (PHYAD[2]) pin for multiple PHY applications--see Section 2.8 for further detail.</p>
COL	O, Z, J	65	<p>COLLISION DETECT: Asserted high to indicate detection of collision conditions in 10 Mb/s and 100 Mb/s Half Duplex modes.</p> <p>During 10BASE-T Half Duplex mode with Heartbeat asserted (bit 4, register 1Ch), this pin is also asserted for a duration of approximately 1μs at the end of transmission to indicate CD heartbeat.</p> <p>In Full Duplex mode, for 10 Mb/s or 100 Mb/s operation, this signal is always logic 0. There is no heartbeat function during 10 Mb/s full duplex operation.</p>
RX_CLK	O, Z	62	<p>RECEIVE CLOCK: Provides the recovered receive clock for different modes of operation:</p> <ul style="list-style-type: none"> • 25 MHz nibble clock in 100 Mb/s mode • 2.5 MHz nibble clock in 10 Mb/s nibble mode • 10 MHz receive clock in 10 Mb/s serial mode
RX_ER (RXD[4]) (PHYAD[4])	O, Z, J	63	<p>RECEIVE ERROR: Asserted high to indicate that an invalid symbol has been detected within a received packet in 100 Mb/s mode.</p> <p>In decoder bypass mode (BP_4B5B or BP_ALIGN modes), RX_ER becomes RXD[4], the new MSB for the receive 5-bit data word.</p> <p>This is also the PHY address sensing (PHYAD) pin for multiple PHY applications--see Section 2.8 for more details.</p>
RX_DV	O, Z, J	64	<p>RECEIVE DATA VALID: Asserted high to indicate that valid data is present on RXD[3:0].</p> <p>This pin is not meaningful during either transparent or phaser mode. Refer to section 3.12 for further detail.</p>
RXD[3] RXD[2] RXD[1] RXD[0]	O, Z, J	55 56 57 58	<p>RECEIVE DATA: Nibble wide receive data (synchronous to RX_CLK, 25 MHz for 100BASE-X mode, 2.5 MHz for 10BASE-T nibble mode). Data is driven on the falling edge of RX_CLK.</p> <p>In 10 Mb/s serial mode, the RXD[0] pin is used as the data output pin which is also clocked out on the falling edge of RX_CLK. During 10 Mb/s serial mode RXD[3:1] become don't care.</p>
RX_EN	I, J	43	<p>RECEIVE ENABLE: Active high enable for receive signals RXD[3:0], RX_CLK, RX_DV and RX_ER. A low on this input tri-states these output pins. For normal operation in a node application this pin should be pulled high.</p>

2.2 100 Mb/s SERIAL PMD INTERFACE

Signal Name	Type	Pin #	Description
SPEED_10	O, J	54	<p>SPEED 10 Mb/s: Indicates 10 Mb/s operation when high. Indicates 100 Mb/s operation when low. This pin can be used to drive peripheral circuitry such as an LED indicator or control circuits for common magnetics.</p>
SPEED_100 (PHYAD[3])	I/O, J	89	<p>SPEED 100 Mb/s: Indicates 100 Mb/s operation when high. Indicates 10 Mb/s operation when low. This pin can be used to drive peripheral circuitry such as an LED indicator or control circuits for common magnetics.</p> <p>This is also the PHY address sensing (PHYAD[3]) pin for multiple PHY applications--see Section 2.8 for more details.</p>

I = TTL/CMOS input O = TTL/CMOS output Z = TRI-STATE output J = IEEE 1149.1 pin

2.0 Pin Description (Continued)

2.2 100 Mb/s SERIAL PMD INTERFACE

ENCSEL (PHYAD[1])	I/O, J	53	<p>ENCODE SELECT: Used to select binary or MLT-3 coding scheme in the PMD transceiver (at the DP83223, logic high selects binary coding scheme and logic low selects MLT-3 coding scheme).</p> <p>This is also the PHY address sensing (PHYAD[1]) pin for multiple PHY applications-see Section 2.8 for more details.</p>
LBEN (PHYAD[0])	I/O, J	49	<p>LOOPBACK ENABLE: For 100BASE-TX operation, this pin should be connected to the Loopback Enable pin of a DP83223 100 Mb/s Transceiver:</p> <p>1 = local 100BASE-TX transceiver Loopback enabled 0 = local 100BASE-TX transceiver Loopback disabled (normal operation)</p> <p>This is also the PHY address sensing (PHYAD[0]) pin for multiple PHY applications-see Section 2.8 for more details.</p> <p>This pin has no effect during 10 Mb/s operation.</p>
TD- TD+	O (ECL)	16 17	<p>TRANSMIT DATA: Differential ECL 125 Mb/s serialized transmit data outputs to the PMD transceiver (such as the DP83223).</p>
SD- SD+	I (ECL)	7 8	<p>SIGNAL DETECT: Differential ECL signal detect inputs. Indicates that the PMD transceiver has detected a receive signal from the twisted pair or fiber media.</p>
RD- RD+	I (ECL)	6 5	<p>RECEIVE DATA: Differential ECL 125 Mb/s receive data inputs from the PMD transceiver (such as the DP83223).</p>

2.3 10 Mb/s INTERFACE

Signal Name	Type	Pin #	Description
REQ	I	29	<p>EQUALIZATION RESISTOR: A resistor connected between this pin and GND or V_{CC} adjusts the equalization step amplitude on the 10BASE-T Manchester encoded transmit data (TXU+/- or TXS+/-). Typically no resistor is required for operation with cable lengths less than 100m. Great care must be taken to ensure system timing integrity when using cable lengths greater than 100m. Refer to the IEEE 802.3u standard, Clause 29 for more details on system topology issues.</p> <p>This value must be determined empirically. Refer to section 3.7.8 for further detail.</p>
RTX	I	28	<p>EXTENDED CABLE RESISTOR: A resistor connected between this pin and GND or V_{CC} adjusts the amplitude of the differential transmit outputs (TXU+/- or TXS+/-). Typically no resistor is required for operation with cable lengths less than 100m. Great care must be taken to ensure system timing integrity when using cable lengths greater than 100m. Refer to the IEEE 802.3u standard, Clause 29 for more details on system topology issues.</p> <p>This value must be determined empirically. Refer to section 3.7.8 for further detail.</p>
TXU- TXU+	O	25 26	<p>UNSHIELDED TWISTED PAIR OUTPUT: This differential output pair sources the 10BASE-T transmit data and link pulses for UTP cable.</p>
TXS- TXS+	O	23 24	<p>SHIELDED TWISTED PAIR OUTPUT: This differential output pair sources the 10BASE-T transmit data and link pulses for STP cable.</p>
RXI- RXI+	I	20 21	<p>TWISTED PAIR RECEIVE INPUT: These are the differential 10BASE-T receive data inputs for either STP or UTP.</p>

I = TTL/CMOS input O = TTL/CMOS output Z = TRI-STATE output J = IEEE 1149.1 pin

2.0 Pin Description (Continued)

2.4 CLOCK INTERFACE

Signal Name	Type	Pin #	Description
REFIN	I	86	REFERENCE INPUT: 25 MHz TTL reference clock input. This clock can be supplied from an external oscillator module or from the CLK25M output (pin 81).
CLK25M	O, Z	81	25 MHz CLOCK OUTPUT: Derived from the 50 MHz OSCIN input. When not in use, this clock output may be shut off through software by setting bit 7 of the PCS Configuration Register at address 17h. This output remains unaffected by hardware and software reset.
OSCIN	I	2	OSCILLATOR INPUT: 50 MHz 50 ppm external TTL oscillator input. If not used, pull down to GND (4.7 k Ω pull down resistor suggested).
X2	O	34	CRYSTAL OSCILLATOR OUTPUT: External 20 MHz 0.005% crystal connection. Used for 10BASE-T timing. When using an external 20 MHz oscillator connected to X1 or with no reference to X1, leave this pin unconnected.
X1	I	33	CRYSTAL OSCILLATOR INPUT: External 20 MHz 0.005% crystal connection. Used for 10BASE-T timing and Auto-Negotiation. If not used, this pin should be pulled up to V _{CC} (4.7 k Ω pull up resistor suggested). When pulled high, the DP83840A detects this condition, enables the internal 2.5 divider, and switches the 10 Mb/s and Auto-Negotiation circuitry to the internally derived 20 MHz clock.

I = TTL/CMOS input O = TTL/CMOS output Z = TRI-STATE output J = IEEE 1149.1 pin

2.0 Pin Description (Continued)

2.5 DEVICE CONFIGURATION INTERFACE

Signal Name	Type	Pin #	Description																																																						
AN0	I	95	<p>AN0: This is a quad state input pin (i.e., 1, M, 0, Clock) that works in conjunction with the AN1 pin to control the forced or advertised operating mode of the DP83840A according to the following table. The value on this pin is set by connecting the input pin to GND (0), V_{CC} (1), a continuous 25 MHz clock (C), or leaving it unconnected (M.) The unconnected state, M, refers to the mid-level ($V_{CC}/2$) set by internal resistors. This value is latched into the DP83840A at power-up/reset. See section 3.9 for more details.</p> <table border="1"> <thead> <tr> <th>AN1</th> <th>AN0</th> <th>Forced Mode</th> </tr> </thead> <tbody> <tr> <td>0</td> <td>M</td> <td>10BASE-T, Half-Duplex without Auto-Negotiation</td> </tr> <tr> <td>1</td> <td>M</td> <td>10BASE-T, Full Duplex without Auto-Negotiation</td> </tr> <tr> <td>M</td> <td>0</td> <td>100BASE-TX, Half-Duplex without Auto-Negotiation</td> </tr> <tr> <td>M</td> <td>1</td> <td>100BASE-TX, Full Duplex without Auto-Negotiation</td> </tr> <tr> <td>C</td> <td>M</td> <td>100BASE-TX, Full Duplex without Auto-Negotiation ANAR, register address 04h default modified</td> </tr> <tr> <td>M</td> <td>C</td> <td>100BASE-TX, Full Duplex without Auto-Negotiation ANAR, register address 04h default modified</td> </tr> <tr> <td>C</td> <td>C</td> <td>100BASE-TX, Half Duplex without Auto-Negotiation ANAR, register address 04h default modified</td> </tr> </tbody> </table> <table border="1"> <thead> <tr> <th>AN1</th> <th>AN0</th> <th>Advertised Mode</th> </tr> </thead> <tbody> <tr> <td>M</td> <td>M</td> <td>All capable (i.e. Full Duplex for 10BASE-T and 100BASE-TX) advertised via Auto-Negotiation</td> </tr> <tr> <td>0</td> <td>0</td> <td>10BASE-T, Half-Duplex advertised via Auto-Negotiation</td> </tr> <tr> <td>0</td> <td>1</td> <td>10BASE-T, Full Duplex advertised via Auto-Negotiation</td> </tr> <tr> <td>1</td> <td>0</td> <td>100BASE-TX, Half-Duplex advertised via Auto-Negotiation</td> </tr> <tr> <td>1</td> <td>1</td> <td>100BASE-TX, Full Duplex advertised via Auto-Negotiation</td> </tr> <tr> <td>C</td> <td>1</td> <td>100BASE-TX Full Duplex and 10BASE-T Full Duplex advertised via Auto-Negotiation</td> </tr> <tr> <td>C</td> <td>0</td> <td>100BASE-TX Half Duplex and 10BASE-T Half Duplex advertised via Auto-Negotiation</td> </tr> <tr> <td>1</td> <td>C</td> <td>100BASE-TX Half Duplex and 100BASE-TX Full Duplex advertised via Auto-Negotiation</td> </tr> <tr> <td>0</td> <td>C</td> <td>10BASE-T Half Duplex and 10BASE-T Full Duplex advertised via Auto-Negotiation</td> </tr> </tbody> </table>	AN1	AN0	Forced Mode	0	M	10BASE-T, Half-Duplex without Auto-Negotiation	1	M	10BASE-T, Full Duplex without Auto-Negotiation	M	0	100BASE-TX, Half-Duplex without Auto-Negotiation	M	1	100BASE-TX, Full Duplex without Auto-Negotiation	C	M	100BASE-TX, Full Duplex without Auto-Negotiation ANAR, register address 04h default modified	M	C	100BASE-TX, Full Duplex without Auto-Negotiation ANAR, register address 04h default modified	C	C	100BASE-TX, Half Duplex without Auto-Negotiation ANAR, register address 04h default modified	AN1	AN0	Advertised Mode	M	M	All capable (i.e. Full Duplex for 10BASE-T and 100BASE-TX) advertised via Auto-Negotiation	0	0	10BASE-T, Half-Duplex advertised via Auto-Negotiation	0	1	10BASE-T, Full Duplex advertised via Auto-Negotiation	1	0	100BASE-TX, Half-Duplex advertised via Auto-Negotiation	1	1	100BASE-TX, Full Duplex advertised via Auto-Negotiation	C	1	100BASE-TX Full Duplex and 10BASE-T Full Duplex advertised via Auto-Negotiation	C	0	100BASE-TX Half Duplex and 10BASE-T Half Duplex advertised via Auto-Negotiation	1	C	100BASE-TX Half Duplex and 100BASE-TX Full Duplex advertised via Auto-Negotiation	0	C	10BASE-T Half Duplex and 10BASE-T Full Duplex advertised via Auto-Negotiation
AN1	AN0	Forced Mode																																																							
0	M	10BASE-T, Half-Duplex without Auto-Negotiation																																																							
1	M	10BASE-T, Full Duplex without Auto-Negotiation																																																							
M	0	100BASE-TX, Half-Duplex without Auto-Negotiation																																																							
M	1	100BASE-TX, Full Duplex without Auto-Negotiation																																																							
C	M	100BASE-TX, Full Duplex without Auto-Negotiation ANAR, register address 04h default modified																																																							
M	C	100BASE-TX, Full Duplex without Auto-Negotiation ANAR, register address 04h default modified																																																							
C	C	100BASE-TX, Half Duplex without Auto-Negotiation ANAR, register address 04h default modified																																																							
AN1	AN0	Advertised Mode																																																							
M	M	All capable (i.e. Full Duplex for 10BASE-T and 100BASE-TX) advertised via Auto-Negotiation																																																							
0	0	10BASE-T, Half-Duplex advertised via Auto-Negotiation																																																							
0	1	10BASE-T, Full Duplex advertised via Auto-Negotiation																																																							
1	0	100BASE-TX, Half-Duplex advertised via Auto-Negotiation																																																							
1	1	100BASE-TX, Full Duplex advertised via Auto-Negotiation																																																							
C	1	100BASE-TX Full Duplex and 10BASE-T Full Duplex advertised via Auto-Negotiation																																																							
C	0	100BASE-TX Half Duplex and 10BASE-T Half Duplex advertised via Auto-Negotiation																																																							
1	C	100BASE-TX Half Duplex and 100BASE-TX Full Duplex advertised via Auto-Negotiation																																																							
0	C	10BASE-T Half Duplex and 10BASE-T Full Duplex advertised via Auto-Negotiation																																																							
AN1	I	46	<p>AN1: This is a quad-state input pin (i.e., 1, M, 0, Clock) that works in conjunction with the AN0 pin to control the forced or advertised operating mode of the DP83840A according to the table given in the AN0 pin description above. The value on this pin is set by connecting the input pin to GND (0), V_{CC} (1), a continuous 25 MHz clock (C), or leaving it unconnected (M.) This value is latched into the DP83840A at power-up/reset. See Section 3.9 for more details.</p>																																																						
REPEATER	I, J	47	<p>REPEATER/NODE MODE: Selects REPEATER mode when set high and NODE mode when set low. In REPEATER mode (or NODE mode with Full Duplex configured), the Carrier Sense (CRS) output from the DP83840A is asserted due to receive activity only. In NODE mode, and not configured for Full Duplex operation, CRS is asserted due to either receive and transmit activity.</p> <p>The Carrier Integrity Monitor (CIM) function is automatically disabled when this pin is set low (node mode) and enabled when this pin is set high (Repeater mode) in order to facilitate 802.3u /D5.3 CIM requirements.</p> <p>At power-up/reset, the value on this pin (set by a pull-up or pull-down resistor, typically 4.7 kΩ) is latched to bit 12 of the PCS Configuration Register, address 17h.</p>																																																						

I = TTL/CMOS input O = TTL/CMOS output Z = TRI-STATE output J = IEEE 1149.1 pin

2.0 Pin Description (Continued)

2.5 DEVICE CONFIGURATION INTERFACE

10BTSER	I, J	98	<p>SERIAL/NIBBLE SELECT:</p> <p>10 Mb/s Serial Operation:</p> <p>When set high, this input selects serial data transfer mode. Transmit and receive data is exchanged serially at a 10 MHz clock rate on the least significant bits of the nibble-wide MII data buses, pins TXD[0] and RXD[0] respectively. This mode is intended for use with the DP83840A connected to a device (MAC or Repeater) using a 10 Mb/s serial interface. Serial operation is not supported in 100 Mb/s mode, therefore this input is ignored during 100 Mb/s operation</p> <p>10 and 100 Mb/s Nibble Operation:</p> <p>When set low, this input selects the MII compliant nibble data transfer mode. Transmit and receive data is exchanged in nibbles on the TXD[3:0] and RXD[3:0] pins respectively.</p> <p>At power-up/reset, the value on this pin (set by a pull-up or pull-down resistor, typically 4.7 kΩ) is latched into bit 9 of the 10BASE-T Status Register at address 1Bh.</p>
BPALIGN	I, J	99	<p>BYPASS ALIGNMENT: Allows 100 Mb/s transmit and receive data streams to bypass all of the transmit and receive operations when set high. Refer to Figures 4 and 5. Note that the PCS signaling (CRS, RX_DV, RX_ER, and COL) is not meaningful during this mode. Additionally TXD[4]/TX_ER is always active.</p> <p>At power-up/reset, the value on this pin (set by a pull-up or pull-down resistor, typically 4.7 kΩ) is latched into bit 12 of the Loopback, Bypass and Receiver Error Mask Register at address 18h.</p>
BP4B5B	I, J	100	<p>BYPASS 4B5B ENCODER/DECODER: Allows 100 Mb/s transmit and receive data streams to bypass the 4B to 5B encoder and 5B to 4B decoder circuits when set high. All PCS signaling (CRS, RX_DV, RX_ER, and COL) remain active and unaffected by this bypass mode. Additionally, TXD[4]/TX_ER is gated by TX_EN. Refer to figures 4 and 5.</p> <p>At power-up/reset, the value on this pin (set by a pull-up or pull-down resistor, typically 4.7 kΩ) is latched into bit 14 of the Loopback, Bypass and Receiver Error Mask Register at address 18h.</p>
BPSCR	I, J	1	<p>BYPASS SCRAMBLER/DESCRAMBLER: Allows 100 Mb/s transmit and receive data streams to bypass the scrambler and descrambler circuits when set high to facilitate 100BASE-FX operation. All PCS signaling (CRS, RX_DV, RX_ER, and COL) remain active and unaffected by this bypass mode. Refer to figures 4 and 5.</p> <p>At power-up/reset, the value on this pin (set by a pull-up or pull-down resistor, typically 4.7 kΩ) is latched into bit 13 of the Loopback, Bypass and Receiver Error Mask Register at address 18h.</p>

I = TTL/CMOS input O = TTL/CMOS output Z = TRI-STATE output J = IEEE 1149.1 pin

2.0 Pin Description (Continued)

2.6 LED INTERFACE

These outputs can be used to drive LEDs directly, or can be used to provide status information to a network management device. Refer to Figure 12 for the LED connection diagram. Refer to section 2.2 for a description of how to generate LED indication of 100 Mb/s mode. **Note that these outputs are standard CMOS voltage drivers and not open-drain.**

Signal Name	Type	Pin #	Description
$\overline{\text{LED1}}$	O, J	42	<p>TRANSMIT LED: Indicates the presence of transmit activity (TXE asserted) for 10 Mb/s and 100 Mb/s operation. Active low.</p> <p>If bit 2 ($\overline{\text{LED1_MODE}}$) of the PCS Configuration Register (address 17h) is set high, then the $\overline{\text{LED1}}$ pin function is changed to indicate the status of the Disconnect Function as defined by the state of bit 5 (CON_STATUS) in the PHY address register (address 19h).</p> <p>The DP83840A incorporates a “monostable” function on the $\overline{\text{LED1}}$ output. This ensures that even minimum size packets generate adequate LED ON time (approximately 50ms) for visibility.</p>
$\overline{\text{LED2}}$	O, J	41	<p>RECEIVE LED: Indicates the presence of any receive activity (CRS active) for 10 Mb/s and 100 Mb/s operation. Active low.</p> <p>The DP83840A incorporates a “monostable” function on the $\overline{\text{LED2}}$ output. This ensures that even minimum size packets generate adequate LED ON time (approximately 50ms) for visibility.</p>
$\overline{\text{LED3}}$	O, J	38	<p>LINK LED: Indicates Good Link status for 10 Mb/s and 100 Mb/s operation. Active low.</p> <p>100 Mb/s Link is established as a result of the assertion of the Signal Detect input to the DP83840A. $\overline{\text{LED3}}$ will assert after SD has remained asserted for a minimum of 500μs. $\overline{\text{LED3}}$ will deassert immediately following the deassertion of Signal Detect.</p> <p>10 Mb/s Link is established as a result of the reception of at least seven consecutive normal Link Pulses or the reception of a valid 10BASE-T packet which will cause the assertion of $\overline{\text{LED3}}$. LED3 will deassert in accordance with the Link Loss Timer as specified in 802.3.</p>
$\overline{\text{LED4}}$	O, J	37	<p>POLARITY/FULL DUPLEX LED: Indicates Good Polarity status for 10 Mb/s operation. Can be configured to Indicate Full Duplex mode status for 10 Mb/s or 100 Mb/s operation. Active low.</p> <p>The DP83840A automatically compensates for polarity inversion. Polarity inversion is indicated by the assertion of $\overline{\text{LED4}}$.</p> <p>If bit 1 ($\overline{\text{LED4_MODE}}$) in the PCS Configuration Register (address 17h) is set high, the $\overline{\text{LED4}}$ pin function is changed to indicate Full Duplex mode status for 10 Mb/s and 100 Mb/s operation.</p>
$\overline{\text{LED5}}$	O, J	36	<p>COLLISION LED: Indicates the presence of collision activity for 10 Mb/s and 100 Mb/s Half Duplex operation. This LED has no meaning for 10 Mb/s or 100 Mb/s Full Duplex operation and will remain deasserted. Active low.</p>

I = TTL/CMOS input O = TTL/CMOS output Z = TRI-STATE output J = IEEE 1149.1 pin

2.0 Pin Description (Continued)

2.7 IEEE 1149.1 INTERFACE

The IEEE 1149.1 Standard Test Access Port and Boundary Scan (sometimes referred to as JTAG) interface signals allow system level boundary scan to be performed. These pins may be left floating when JTAG testing is not required.

Signal Name	Type	Pin #	Description
TDO	O, Z	50	TEST DATA OUTPUT: Serial instruction/test output data for the IEEE 1149.1 scan chain. If Boundary-Scan is not implemented this pin may be left unconnected (NC).
TDI	I	91	TEST DATA INPUT: Serial instruction/test input data for the IEEE 1149.1 scan chain.
$\overline{\text{TRST}}$	I	92	TEST RESET: An asynchronous low going pulse will reset and initialize the IEEE 1149.1 test circuitry. If Boundary-Scan is not implemented, this pin may be left unconnected (NC) since it has an internal pull-up resistor (10 k Ω).
TCLK	I	93	TEST CLOCK: Test clock for the IEEE 1149.1 circuitry. If Boundary-Scan is not implemented this pin may be left unconnected (NC).
TMS	I	94	TEST MODE SELECT: Control input to the IEEE 1149.1 test circuitry. If Boundary-Scan is not implemented, this pin may be left unconnected (NC) since it has an internal pull-up resistor (10 k Ω).

I = TTL/CMOS input O = TTL/CMOS output Z = TRI-STATE output J = IEEE 1149.1 pin

2.0 Pin Description (Continued)

2.8 PHY ADDRESS INTERFACE

The DP83840A PHYAD[4:0] inputs provide up to 32 unique PHY address options. **An address selection of all zeros (00000) will result in a PHY isolation condition.** See the Isolate bit description in the BMCR, address 00h, Section 4.2 for further detail.

Signal Name	Type	Pin #	Description
PHYAD[0] (LBEN)	I/O, J	49	<p>PHY ADDRESS [0]: PHY address sensing pin (bit 0) for multiple PHY applications. PHY address sensing is achieved by strapping a pull-up/pull-down resistor (typically 4.7 kΩ) to this pin as required.</p> <p>The pull-up/pull-down status of this pin is latched into the PHYAD address register (address 19h) during power up/reset.</p> <p>This pin is also the Loopback Enable output pin (LBEN) for the 100 Mb/s Serial PMD Interface. See Section 2.2 for further detail.</p>
PHYAD[1] (ENCSEL)	I/O, J	53	<p>PHY ADDRESS [1]: PHY address sensing pin (bit 1) for multiple PHY applications. PHY address sensing is achieved by strapping a pull-up/pull-down resistor (typically 4.7 kΩ) to this pin as required.</p> <p>The pull-up/pull-down status of this pin is latched into the PHYAD address register (address 19h) during power up/reset.</p> <p>This pin is also the Encode Select output pin (ENCSEL) for the 100 Mb/s Serial PMD Interface. See Section 2.2 for further detail.</p>
PHYAD[2] (CRS)	I/O, Z, J	66	<p>PHY ADDRESS [2]: PHY address sensing pin (bit 2) for multiple PHY applications. PHY address sensing is achieved by strapping a pull-up/pull-down resistor (typically 4.7 kΩ) to this pin as required.</p> <p>The pull-up/pull-down status of this pin is latched into the PHYAD address register (address 19h) during power up/reset.</p> <p>This pin is also the Carrier Sense output pin (CRS) for the MII Interface. See Section 2.1 for further detail.</p>
PHYAD[3] (SPEED_100)	I/O, J	89	<p>PHY ADDRESS [3]: PHY address sensing pin (bit 3) for multiple PHY applications. PHY address sensing is achieved by strapping a pull-up/pull-down resistor (typically 4.7 kΩ) to this pin as required.</p> <p>The pull-up/pull-down status of this pin is latched into the PHYAD address register (address 19h) during power up/reset.</p> <p>This pin is also the Speed 100 Mb/s output pin (SPEED_100) for optional control of peripheral circuitry. See Section 2.2 for further detail.</p>
PHYAD[4] (RX_ER)	I/O, Z, J	63	<p>PHY ADDRESS [4]: PHY address sensing pin (bit 4) for multiple PHY applications. PHY address sensing is achieved by strapping a pull-up/pull-down resistor (typically 4.7 kΩ) to this pin as required.</p> <p>The pull-up/pull-down status of this pin is latched into the PHYAD address register (address 19h) during power up/reset.</p> <p>This pin is also the Receive Error output pin (RX_ER) for the MII Interface. See Section 2.1 for further detail.</p>

2.9 MISCELLANEOUS

Signal Name	Type	Pin #	Description
RESET	I, J	44	RESET: Active high input that initializes or reinitializes the DP83840A. See section 3.10 for further detail.
LOWPWR	I, J	3	LOW POWER MODE SELECT: Active high input that enables the low power mode (100 Mb/s operation only). See section 3.13 for further detail.

I = TTL/CMOS input O = TTL/CMOS output Z = TRI-STATE output J = IEEE 1149.1 pin

2.10 POWER AND GROUND PINS

The power (V_{CC}) and ground (GND) pins of the DP83840A are grouped in pairs into four categories--TTL/CMOS Input pairs, TTL/CMOS Output and I/O pairs, 10 Mb/s pairs and 100 Mb/s pairs. This grouping allows for optimizing the layout and filtering of the power and ground supplies to this device. Refer to section 5.0 for further detail relating to power supply filtering.

Signal Name	Pin #	Description
GROUP A - TTL/CMOS INPUT SUPPLY PAIRS		
IOVCC1, IOGND1	96, 97	TTL Input/Output Supply #1
IOVCC2, IOGND2	39, 40	TTL Input/Output Supply #2
IOVCC3, IOGND3	51, 52	TTL Input/Output Supply #3
PCSVCC, PCSGND	70, 71	Physical Coding Sublayer Supply
GROUP B- TTL/CMOS OUTPUT AND I/O SUPPLY PAIRS		
IOVCC4, IOGND4	59, 60	TTL Input/Output Supply #4
RCLKGND	61	Receive Clock Ground, No paired V_{CC}
IOVCC5, IOGND5	68, 69	TTL Input/Output Supply #5
IOVCC6, IOGND6	79, 80	TTL Input/Output Supply #6
REFVCC, REFGND	84, 85	25 MHz Clock Supply
GROUP C- 10 Mb/s SUPPLY PAIRS		
RXVCC, RXGND	18, 19	Receive Section Supply
TDVCC, TDGND	22, 27	Transmit Section Supply
PLLCC, PLLGND	31, 30	Phase Locked Loop Supply
OVCC, OGN	32, 35	Internal Oscillator Supply
GROUP D- 100 Mb/s SUPPLY PAIRS		
ANAVCC, ANAGND	9, 10	Analog Section Supply
CRMVCC, CRMGND	12, 11	Clock Recovery Module Supply
ECLVCC	15	ECL Outputs Supply
CGMVCC, CGMGND	87, 88	Clock Generator Module Supply

2.11 SPECIAL CONNECT PINS

Signal Name	Type	Pin #	Description
NC		13 14 83	NO CONNECT: These pins are reserved for future use. Leave them unconnected (floating).
RES_0		4	RESERVED_0: These pins are reserved for future use. This pin must be connected to ground. For future upgradability, connect this pin to GND via a 0Ω resistor.
RES_0	J	45 48 90	RESERVED_0: These pins are reserved for future use. These pins must be connected to ground. For future upgradability, connect these pins to GND via 0Ω resistors.

I = TTL/CMOS input O = TTL/CMOS output Z = TRI-STATE output J = IEEE 1149.1 pin

3.0 Functional Description

The DP83840A 10/100 Mb/s Ethernet Physical Layer integrates a 100BASE-X Physical Coding Sub-layer (PCS) and a complete 10BASE-T module in a single chip. It provides a standard Media Independent Interface (MII) to communicate between the Physical Signaling and the Medium Access Control (MAC) layers for both 100BASE-X and 10BASE-T operations. It interfaces to a 100 Mb/s Physical Medium Dependent (PMD) transceiver, such as the DP83223.

The 100BASE-X section of the device consists of the following functional blocks:

- Transmitter
- Receiver
- Clock Generation Module (CGM)
- Clock Recovery Module (CRM)

The 10BASE-T section of the device consists primarily of the 10 Mb/s transceiver module with filters and an ENDEC module.

The 100BASE-X and 10BASE-T sections share the following functional blocks:

- PCS Control
- MII Registers
- IEEE 1149.1 Controller
- IEEE 802.3u Auto-Negotiation

A description of each of these functional blocks follows.

3.1 PCS CONTROL

The IEEE 802.3u 100BASE-X Standard defines the Physical Coding Sublayer (PCS) as the transmit, receive and carrier sense functions. These functions within the DP83840A are controlled via external pins and internal registers via the MII serial management interface.

3.1.1 100BASE-X Bypass Options

The DP83840A incorporates a highly flexible transmit and receive channel architecture. Each of the major 100BASE-X transmit and receive functional blocks of the DP83840A may be selectively bypassed to provide increased flexibility for various applications.

3.1.1.1 Bypass 4B5B and 5B4B

The 100BASE-X 4B5B code-group encoder in the transmit channel and the 100BASE-X 5B4B code-group decoder in the receive channel may be bypassed by setting the BP_4B5B bit in the LBREMR (bit 14, register address 18h). The default value for this bit is set by the BP4B5B pin 100 at power-up/reset. This mode of operation is referred to as the "Transparent" mode as further defined in section 3.12.

3.1.1.2 Bypass Scrambler and Descrambler

The 100BASE-T scrambler in the transmit channel and the 100BASE-T descrambler in the receive channel may be bypassed by setting the BP_SCR bit in the LBREMR (bit 13, register address 18h). The default value for this bit is set by the BPSCR signal (pin 1) at power-up/reset. This bypass option has been included to facilitate 100BASE-FX operation where data scrambling is not required.

3.1.1.3 Bypass NRZI Encoder and Decoder

The 100BASE-X NRZI encoder in the transmit channel and the 100BASE-X NRZI decoder in the receive channel may be bypassed by setting the NRZI_EN bit in the PCR (bit 15, register address 17h). The default for this bit is a 1, which enables the NRZI encoder and decoder. This bypass option has been included for test purposes only and should not be selected during normal 100BASE-X operation.

3.1.1.4 Bypass Align

The 100BASE-X transmit channel operations (4B5B code-group encoder, scrambler and NRZ to NRZI) and the 100BASE-X receive channel operations (NRZI to NRZ, descrambler and 4B5B code-group decoding) may all be bypassed by setting the BP_ALIGN bit in the LBREMR (bit 12, register address 18h). The default value for this bit is set by the BP_ALIGN signal (pin 99) at power-up/reset.

The bypass align function is intended for those repeater applications where none of the transmit and receive channel operations are required. This mode of operation is referred to as the "Phaser" mode as further defined in section 3.12

3.1.2 Repeater Mode

The DP83840A Carrier Sense (CRS) operation depends on the value of the REPEATER bit in the PCR (bit 12, register address 17h). When set high, the CRS output (pin 66) is asserted for receive activity only. When set low, the CRS output is asserted for either receive or transmit activity. The default value for this bit is set by the REPEATER pin 47 at power-up/reset.

When the Repeater mode of operation is selected during 10 Mb/s operation, all functional parameters other than CRS remain unaffected. CRS will respond only to receive activity during 10 Mb/s repeater mode.

When the repeater mode of operation is selected during 100 Mb/s operation, there are three parameters that are directly effected. First, as with 10 Mb/s Repeater operation, CRS will only respond to receive activity.

Second, in compliance with D5 of the 802.3 standard, the Carrier Integrity Monitor (CIM) function is automatically enabled for detection and reporting of bad start of stream delimiters (whereas in node mode the CIM is disabled).

Finally, the deassertion of CRS during the reception of a long Jabber event is effected by the selection of the repeater mode. If the repeater mode is selected, CRS will remain asserted even if a long Jabber event (>722us) occurs. This facilitates proper handling of a jabber event by the Repeater Controller device. This Jabber related CRS function can be over-riden. Refer to section 4.15 (bit 11 of register 19h) for further detail.

3.1.3 MII Control

The DP83840A provides three basic MII modes of operation:

3.1.3.1 100 Mb/s Operation

For 100 Mb/s operation, the MII operates in nibble mode with a clock rate of 25 MHz. This clock rate is independent of bypass conditions.

In normal (non-bypassed) operation the MII data at RXD[3:0] and TXD[3:0] is nibble wide. In bypass mode (BP_4B5B or BP_ALIGN set) the MII data takes the form of

3.0 Functional Description (Continued)

5-bit code-groups. The lower significant 4 bits appear on TXD[3:0] and RXD[3:0] as normal, and the most significant bits (TXD[4] and RXD[4]) appear on the TX_ER and RX_ER pins respectively.

3.1.3.2 10 Mb/s Nibble Mode Operation

For 10 Mb/s nibble mode operation, the MII clock rate is 2.5 MHz. The 100BASE-X bypass functions do not apply to 10 Mb/s operation.

3.1.3.3 10 Mb/s Serial Mode Operation

For applications based on serial repeater controllers for 10 Mb/s operation, the DP83840A accepts NRZ serial data on the TXD[0] input and provides NRZ serial data output on RXD[0] with a clock rate of 10 MHz. The unused MII inputs and outputs (TXD[3:1] and RXD[3:1]) are ignored during serial mode. The PCS control signals, CRS, COL, TX_ER, RX_ER, and RX_DV, continue to function normally.

This mode is selected by setting the 10BT_SER bit in the 10BTSR (bit 9, register address 1Bh). The default value for this bit is set by the 10BTSER pin 98 at power-up/reset.

3.2 MII SERIAL MANAGEMENT REGISTER ACCESS

The MII specification defines a set of thirty-two 16-bit status and control registers that are accessible through the serial management data interface pins MDC and MDIO. The DP83840A implements all the required MII registers as well as several optional registers. These registers are fully described in Section 4. A description of the serial management access protocol follows.

3.2.1 Serial Management Access Protocol

The serial control interface consists of two pins, Management Data Clock (MDC) and Management Data Input/Output (MDIO). MDC has a maximum clock rate of 2.5 MHz and no minimum rate. The MDIO line is bi-directional and may be shared by up to 32 devices. The MDIO frame format is shown in Table I.

The MDIO pin requires a pull-up resistor (1.5KΩ) which, during IDLE and Turnaround, will pull MDIO high. Prior to initiating any transaction, the station management entity sends a sequence of 32 contiguous logic ones on MDIO to provide the DP83840A with a sequence that can be used to establish synchronization. This preamble may be generated either by driving MDIO high for 32 consecutive MDC clock cycles, or by simply allowing the MDIO pull-up resistor to pull the MDIO PHY pin high during which time 32 MDC clock cycles are provided.

The DP83840A waits until it has received this preamble sequence before responding to any other transaction. Once the DP83840A serial management port has initialized no further preamble sequencing is required until after a Reset/Power-on has occurred.

The Start code is indicated by a <01> pattern. This assures the MDIO line transitions from the default idle line state.

Turnaround is an idle bit time inserted between the Register Address field and the Data field. To avoid contention, no device actively drives the MDIO signal during the first bit of Turnaround during a read transaction. The addressed DP83840A drives the MDIO with a zero for

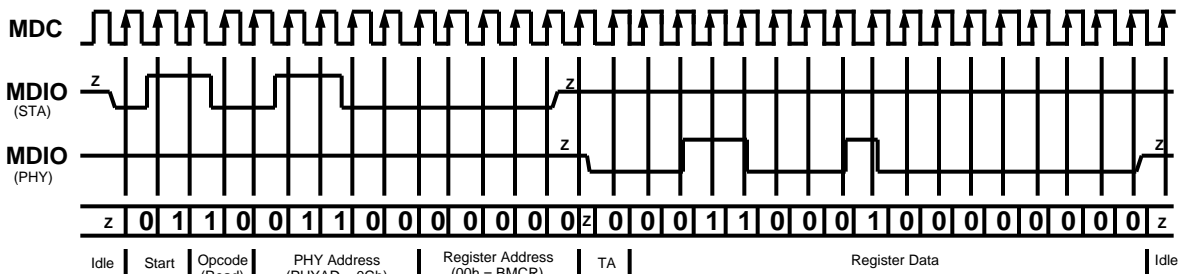

FIGURE 2. Typical MDC/MDIO Read Operation

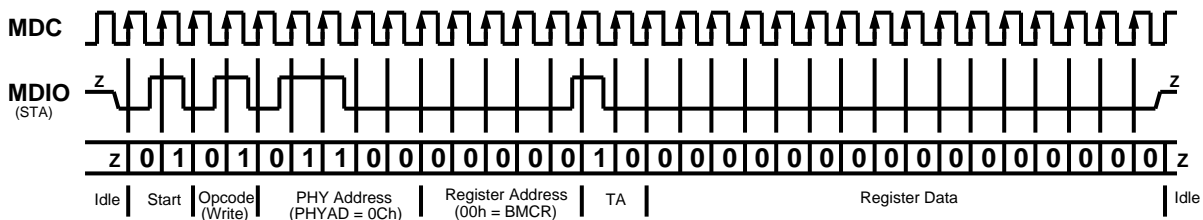

FIGURE 3. Typical MDC/MDIO Write Operation

Table I.

MII Management Serial Protocol	<idle><start><op code><device addr> <reg addr><turnaround><data><idle>
Read Operation	<idle><01><10><AAAAA> <RRRRR><Z0><xxxx xxxx xxxx xxxx><idle>
Write Operation	<idle><01><01><AAAAA> <RRRRR><10><xxxx xxxx xxxx xxxx><idle>

3.0 Functional Description (Continued)

the second bit of Turnaround and follows this with the required data. Figure 2 shows the timing relationship between MDC and the MDIO as driven/received by the Station Management Entity (STA) and the DP83840A (PHY) for a typical register read access.

For write transactions, the station management entity writes data to an addressed DP83840A eliminating the requirement for MDIO Turnaround. The Turnaround time is filled by the management entity inserting <10> for these two bits. Figure 3 shows the timing relationship for a typical MII register write access.

3.2.1.1 Preamble Suppression

The DP83840A supports a Preamble Suppression mode as indicated by a one in bit 6 of the Basic Mode Status Register (BMSR, address 01h.) If the station management entity (i.e. MAC or other management controller) determines that all PHYs in the system support Preamble Suppression by returning a one in this bit, then the station management entity need not generate preamble for each management transaction.

The DP83840A requires a single initialization sequence of 32 bits of preamble following power-up/hardware reset. This requirement is generally met by the mandatory pull-up resistor on MDIO or the management access made to determine whether Preamble Suppression is supported.

While the DP83840A will respond to management accesses without preamble, *a minimum of one idle bit between management transactions is required* as specified in IEEE 802.3u.

3.2.2 PHY Address Sensing

The DP83840A can be set to respond to any of the possible 32 PHY addresses. Each DP83840A connected to a common serial MII must have a unique address. It should be noted that while an address selection of all zeros <00000> will result in PHY Isolate mode, this will not effect serial management access.

The DP83840A provides five PHY address pins, the state of which are latched into the PHY Address Register (PAR) at system power-up/reset. These pins are described in Section 2.8. For further detail relating to the latch-in timing requirements of the PHY Address pins, as well as the other hardware configuration pins, refer to section 3.10.

3.2.3 MII Management

The MII may be used to connect PHY devices to MAC or repeater devices in 10/100 Mb/s systems.

The management interface of the MII allows the configuration and control of multiple PHY devices, the gathering of status and error information, and the determination of the type and abilities of the attached PHY(s).

3.2.4 MII Isolate Mode

A 100BASE-X PHY connected to the mechanical MII interface specified in IEEE 802.3u is required to have a default value of one in bit 10 of the Basic Mode Control Register (BMCR, address 00h.) The DP83840A will set this bit to one if the PHY Address is set to 00000 upon power-up/hardware reset. Otherwise, the DP83840A will set this bit to zero upon power-up/hardware reset.

With bit 10 in the BMCR set to one the DP83840A does not respond to packet data present at TXD[3:0], TX_EN, and TX_ER inputs and presents a high impedance on the TX_CLK, RX_CLK, RX_DV, RX_ER, RXD[3:0], COL, and CRS outputs. The CLK_25M output remains active and the DP83840A will continue to respond to all management transactions.

While in Isolate mode, the TD +/-, TXU +/-, and TXS +/- outputs will not transmit packet data. However, the DP83840A will default to 100 Mb/s mode and source 100BASE-X Idles during the Isolate condition. Data present on the RD +/- and RXI +/- inputs is ignored and the link will be forced to disable.

3.3 100BASE-X TRANSMITTER

The 100BASE-X transmitter consists of functional blocks which convert synchronous 4-bit nibble data, as provided by the MII, to a scrambled 125 Mb/s serial data stream. This data stream may be routed either to a twisted pair PMD such as the DP83223 TWISTER for 100BASE-TX signaling, or to an optical PMD for 100BASE-FX applications. The block diagram in Figure 4 provides an overview of each functional block within the 100BASE-X transmit section.

The Transmitter section consists of the following functional blocks:

- code-group Encoder and Injection block (bypass option)
- Scrambler block (bypass option)
- NRZ to NRZI encoder block (bypass option)

The bypass option for each of the functional blocks within the 100BASE-X transmitter provides flexibility for applications such as 100 Mb/s repeaters where data conversion is not always required.

3.3.1 100 Mb/s Transmit State Machine

The DP83840A implements the 100BASE-X transmit state machine diagram as given in the IEEE 802.3u Standard, Clause 24.

3.3.2 Code-group Encoding and Injection

The code-group encoder converts 4 bit (4B) nibble data generated by the MAC into 5 bit (5B) code-groups for transmission. This conversion is required to allow control data to be combined with packet data code-groups. Refer to Table II for 4B to 5B code-group mapping details.

The code-group encoder substitutes the first 8 bits of the MAC preamble with a J/K code-group pair (11000 10001). The code-group encoder continues to replace subsequent 4B data with corresponding 5B code-groups. At the end of the transmit packet, upon the deassertion of Transmit Enable signal from the MAC or Repeater, the code-group encoder injects the T/R code-group pair (01101 00111) indicating end of frame.

After the T/R code-group pair, the code-group encoder continuously injects IDLEs into the transmit data stream until the next transmit packet is detected (reassertion of Transmit Enable).

3.3.3 Scrambler

The scrambler is required to control the radiated emissions at the media connector and on the twisted pair cable (for

3.0 Functional Description (Continued)

100BASE-TX applications). By scrambling the data, the total energy launched onto the cable is randomly distributed over a wide frequency range. Without the scrambler, energy levels at the PMD and on the cable would peak beyond FCC limitations at frequencies related to repeating 5B sequences (i.e., continuous transmission of IDLEs).

The scrambler is configured as a closed loop linear feedback shift register (LFSR) with an 11-bit polynomial. The output of the closed loop LFSR is combined with the NRZ 5B data from the code-group encoder via an X-OR logic function. The result is a scrambled data stream with sufficient randomization to decrease radiated emissions at certain frequencies by as much as 20 dB. The DP83840A uses the PHYID as determined by the PHYAD [4:0] pins to set a unique seed value for the scrambler so that the total energy produced by a multi-PHY application (i.e. repeater) distributes the energy across the spectrum and reduces overall EMI.

3.3.4 NRZ to NRZI Encoder

After the transmit data stream has been scrambled and serialized, the data must be NRZI encoded in order to comply with the TP-PMD standard for 100BASE-TX transmission over Category-5 un-shielded twisted pair cable. Normal operation for both twisted pair and fiber applications requires that this encoder remain engaged. This encoder should only be bypassed for system testing and or debug.

3.3.5 TX_ER

Assertion of the TX_ER input while the TX_EN input is also asserted will cause the DP83840A to substitute HALT code-groups for the 5B data present at TXD[3:0]. However, the SSD (/J/K/) and ESD (/T/R/) will not be substituted with Halt code-groups. As a result, the assertion of TX_ER while TX_EN is asserted will result in a frame properly encapsulated with the /J/K/ and /T/R/ delimiters which contains HALT code-groups in place of the data code-groups.

3.4 100BASE-X RECEIVER

The 100BASE-X receiver consists of several functional blocks which are required to recover and condition the 125 Mb/s receive data stream as specified by the IEEE 802.3u Standard. The 125 Mb/s receive data stream may originate from a twisted pair transceiver such as the DP83223 TWISTER in a 100BASE-TX application. Alternatively, the receive data stream may be generated by an optical receiver as in a 100BASE-FX application. The block diagram in Figure 5 provides an overview of each functional block within the 100BASE-X receive section.

The Receiver block consists of the following functional blocks:

- Clock Recovery block
- NRZI to NRZ decoder block (bypass option)
- Descrambler block (bypass option)
- code-group Alignment block (bypass option)
- 5B/4B code-group Decoder block (bypass option)
- Collision Detect block
- Carrier Sense block
- 100 Mb/s Receive State Machine

- Far End Fault Indication block
- Link Integrity Monitor block
- Carrier Integrity Monitor Block

The bypass option for each of the functional blocks within the 100BASE-X receiver provides flexibility for applications such as 100 Mb/s repeaters where data conversion is not always required.

3.4.1 Clock Recovery

The Clock Recovery Module (CRM) accepts 125 Mb/s scrambled or unscrambled NRZI data from an external twisted pair or fiber PMD receiver. The CRM locks onto the 125 Mb/s data stream and extracts a 125 MHz reference clock. The extracted and synchronized clock and data are used as required by the synchronous receive operations as generally depicted in Figure 5.

The CRM is implemented using an advanced digital Phase Locked Loop (PLL) architecture that replaces sensitive analog circuits. Using digital PLL circuitry allows the DP83840A to be manufactured and specified to tighter tolerances.

3.4.2 NRZI to NRZ

In a typical application the NRZI to NRZ decoder is required in order to present NRZ formatted data to the descrambler (or to the code-group alignment block if the descrambler is bypassed).

The receive data stream, as recovered by the PMD receiver, is in NRZI format, therefore the data must be decoded to NRZ before further processing.

3.4.3 Descrambler

A 5-bit parallel (code-group wide) descrambler is used to de-scramble the receive NRZ data. To reverse the data scrambling process, the descrambler has to generate an identical data scrambling sequence (N) in order to recover the original unscrambled data (UD) from the scrambled data (SD) as represented in the equations:

$$SD = (UD \oplus N)$$

$$UD = (SD \oplus N)$$

Synchronization of the descrambler to the original scrambling sequence (N) is achieved based on the knowledge that the incoming scrambled data stream consists of scrambled IDLE data. After the descrambler has recognized 16 consecutive IDLE code-groups, where an IDLE code-group in 5B NRZ is equal to five consecutive ones (11111), it will synchronize to the receive data stream and generate unscrambled data in the form of unaligned 5B code-groups.

In order to maintain synchronization, the descrambler must continuously monitor the validity of the unscrambled data that it generates. To ensure this, a line state monitor and a hold timer are used to constantly monitor the synchronization status. Upon synchronization of the descrambler the hold timer starts a 722 μ s countdown. Upon detection of sufficient IDLE code-groups within the 722 μ s period, the hold timer will reset and begin a new countdown. This monitoring operation will continue indefinitely given a properly operating network connection with good signal integrity. If the line state monitor does not recognize sufficient unscrambled IDLE code-groups within the 722 μ s period, the entire descrambler will be forced out

3.0 Functional Description (Continued)

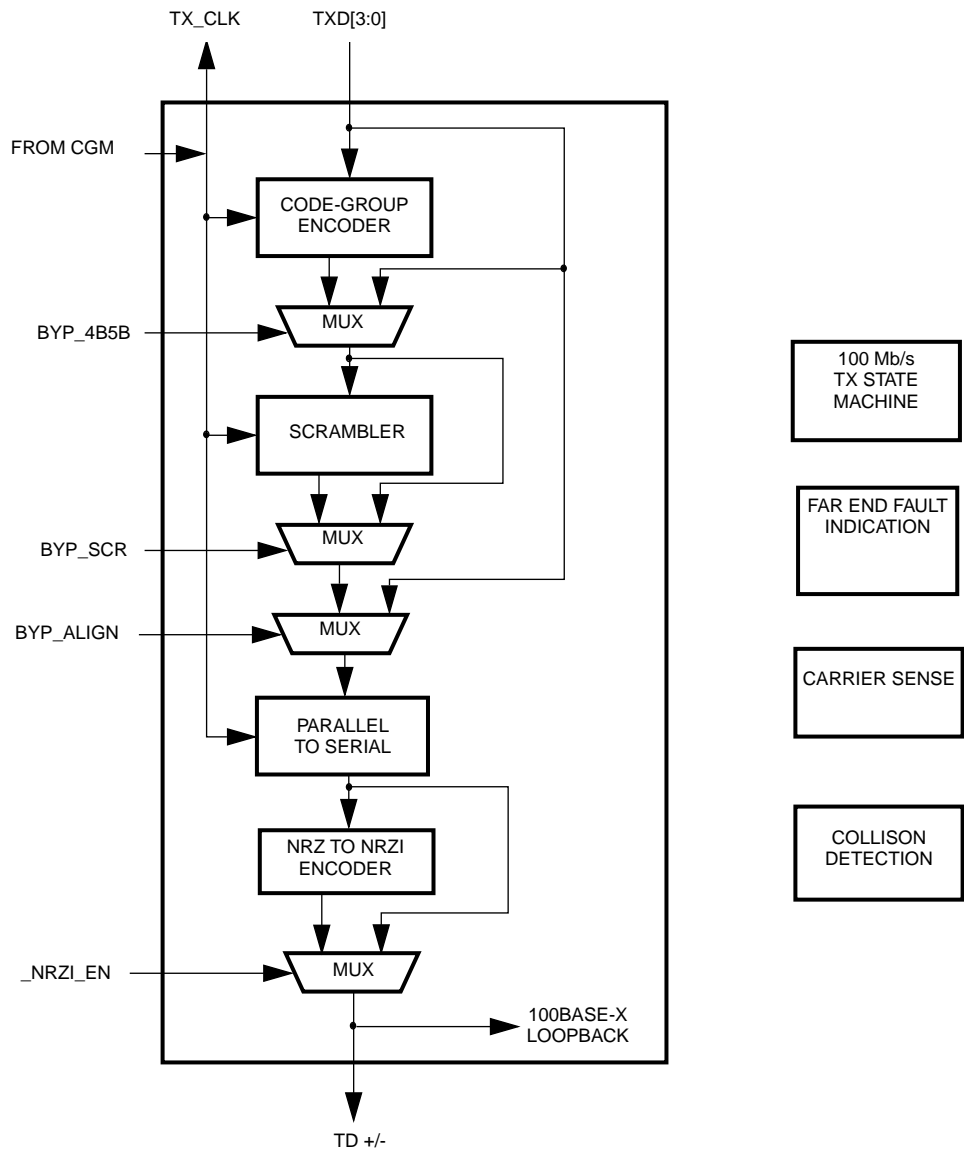

FIGURE 4. 100BASE-X Transmitter

3.0 Functional Description (Continued)

Table II. 4B5B code-group Encoding/Decoding.

Name	PCS 5B Code-group	MII 4B Nibble Code
DATA CODES		
0	11110	0000
1	01001	0001
2	10100	0010
3	10101	0011
4	01010	0100
5	01011	0101
6	01110	0110
7	01111	0111
8	10010	1000
9	10011	1001
A	10110	1010
B	10111	1011
C	11010	1100
D	11011	1101
E	11100	1110
F	11101	1111
IDLE AND CONTROL CODES		
H	00100	Halt code-group - Error code
I	11111	Inter-Packet Idle - 0000*
J	11000	First Start of Packet - 0101*
K	10001	Second Start of Packet - 0101*
T	01101	First End of Packet - 0000*
R	00111	Second End of Packet - 0000*
INVALID CODES		
V	00000	0110 or 0101*
V	00001	0110 or 0101*
V	00010	0110 or 0101*
V	00011	0110 or 0101*
V	00101	0110 or 0101*
V	00110	0110 or 0101*
V	01000	0110 or 0101*
V	01100	0110 or 0101*
V	10000	0110 or 0101*
V	11001	0110 or 0101*

*Control code-groups I, J, K, T and R in data fields will be mapped as invalid codes, together with RX_ER asserted.

**Normally, invalid codes (V) are mapped to 6h on RXD[3:0] with RX_ER asserted. If the CODE_ERR bit in the LBREMR (bit 4, register address 18h) is set, the invalid codes are mapped to 5h on RXD[3:0] with RX_ER asserted. Refer to section 4.14 for further detail.

3.0 Functional Description (Continued)

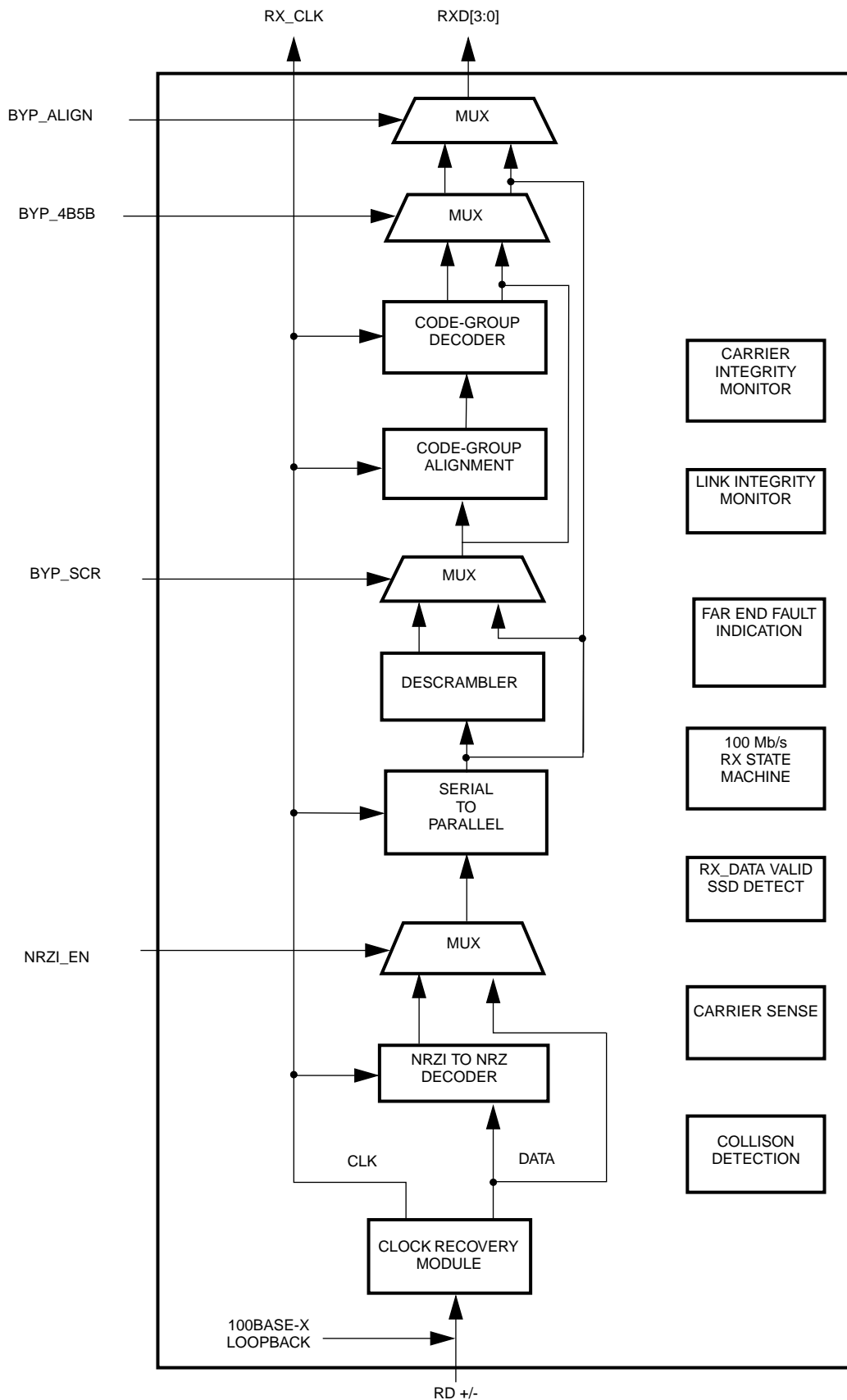

FIGURE 5. 100BASE-X Receiver

3.0 Functional Description (Continued)

of the current state of synchronization and reset in order to re-acquire synchronization.

The value of the time-out for this timer may be modified from 722 μ s to 2 ms by setting bit 14 of the PCR (address 17h) to one. The 2 ms option allows applications with Maximum Transmission Units (packet sizes) larger than IEEE 802.3 to maintain descrambler synchronization (i.e. Token Ring/Fast-Ethernet switch/router applications).

Additionally, this timer may be disabled entirely by setting bit 13 of the PCR (address 17h) to one. The disabling of the time-out timer is not recommended as this will eventually result in a lack of synchronization between the transmit scrambler and the receive descrambler which will corrupt data.

3.4.4 Code-group Alignment

The code-group alignment module operates on unaligned 5-bit data from the descrambler (or, if the descrambler is bypassed, directly from the NRZI/NRZ decoder) and converts it into 5B code-group data (5 bits). code-group alignment occurs after the J/K code-group pair is detected. Once the J/K code-group pair (11000 10001) is detected, subsequent data is aligned on a fixed boundary.

3.4.5 Code-group Decoder

The code-group decoder functions as a look up table that translates incoming 5B code-groups into 4B nibbles. The code-group decoder first detects the J/K code-group pair preceded by IDLE code-groups and replaces the J/K with MAC preamble. Specifically, the J/K 10-bit code-group pair is replaced by the nibble pair (0101 0101). All subsequent 5B code-groups are converted to the corresponding 4B nibbles for the duration of the entire packet. This conversion ceases upon the detection of the T/R code-group pair denoting the End of Stream Delimiter (ESD) or with the reception of a minimum of two IDLE code-groups.

3.4.6 Collision Detect

Half Duplex collision detection for 100 Mb/s follows the model of 10BASE-T (refer to section 3.7.3). Collision detection is indicated by the COL pin of the MII whenever both the transmit and receive functions within the DP83840A attempt to process packet data simultaneously.

For Full Duplex applications the COL signal is never asserted.

3.4.7 Carrier Sense

Carrier Sense (CRS) is asserted, as a function of receive activity, upon the detection of two non-contiguous zeros occurring within any 10-bit boundary of the receive data stream. CRS is asserted, as a function of transmit activity (depending on the mode of operation), whenever the TX_EN (transmit enable) input to the DP83840A is asserted.

For 100 Mb/s Half Duplex operation (non-repeater mode), CRS is asserted during either packet transmission or reception.

In REPEATER mode (pin 47/bit 12, register address 17h), CRS is only asserted due to receive activity.

For 100 Mb/s Full Duplex operation, the behavior of CRS depends on bit 6 of the LBREMR (address 18h). If this bit is zero, then CRS is asserted only due to receive activity. If this bit is one, then CRS is asserted only due to transmit

activity. This operation allows flexibility for interfacing a Full Duplex MAC to the DP83840A.

When the IDLE code-group pair is detected in the receive data stream, CRS is deasserted. In modes where transmit activity results in the assertion of CRS, the deassertion of TX_EN results in the immediate deassertion of CRS.

The carrier sense function is independent of code-group alignment.

3.4.8 100 Mb/s Receive State Machine

The DP83840A implements the 100BASE-X receive state machine diagram as given in ANSI/IEEE Standard 802.3u/D5, Clause 24.

3.4.9 100BASE-X Link Integrity Monitor

The 100BASE-X Link Integrity Monitor function (LIM) allows the receiver to ensure that reliable data is being received. Without reliable data reception, the LIM will halt both transmit and receive operations until such time that a valid link is detected (i.e. good link.)

If Auto-Negotiation is not enabled, then a valid link will be indicated once SD+/- is asserted continuously for 500 μ s.

If Auto-Negotiation is enabled, then Auto-Negotiation will further qualify a valid link as follows:

- The descrambler must receive a minimum of 15 IDLE code groups for proper link initialization

- Auto-Negotiation must determine that the 100BASE-X function should be enabled.

A valid link may be detected externally by either the $\overline{\text{LED3}}$ output or by reading bit 2 of the Basic Mode Status Register (address 01h.)

3.4.10 Bad SSD Detection

A Bad Start of Stream Delimiter (Bad SSD) is an error condition that occurs in the 100BASE-X receiver if carrier is detected (CRS asserted) and a valid /J/K/ set of code groups (SSD) is not received.

If this condition is detected, then the DP83840A will assert RX_ER and present RXD[3:0] = 1110 to the MII for the cycles that correspond to received 5B code-groups until at least two IDLE code groups are detected. In addition, the False Carrier Event Counter (address 12h) and the RX_ER Counter (address 15h) will be incremented by one.

Once at least two IDLE code groups are detected, RX_ER and CRS become de-asserted.

RX_ER becomes RXD[4] in transparent mode (Bypass_4B5B), such that RXD[4:0]=11110 during a Bad SSD event.

When bit 12 of the LBREMR is one (Bypass Align mode), RXD[3:0] and RX_ER/RXD[4] are not modified regardless of the state of bit 15 of the LBREMR (Bad SSD Enable.)

Disabling the Bad SSD function supports non-IEEE 802.3u compliant applications.

3.4.11 Far End Fault Indication

Auto-Negotiation provides a mechanism for transferring information from the Local Station to the Link Partner that a remote fault has occurred for 100BASE-TX. As Auto-Negotiation is not currently specified for operation over fiber, the Far End Fault Indication function (FEFI) provides this capability for 100BASE-FX applications.

3.0 Functional Description (Continued)

A remote fault is an error in the link that one station can detect while the other cannot. An example of this is a disconnected wire at a station's transmitter. This station will be receiving valid data and detect that the link is good via the Link Integrity Monitor, but will not be able to detect that its transmission is not propagating to the other station.

A 100BASE-FX station that detects such a remote fault may modify its transmitted IDLE stream from all ones to a group of 84 ones followed by a single zero (i.e. 16 IDLE code groups followed by a single Data 0 code group.) This is referred to as the FEFI IDLE pattern.

If the FEFI function has been enabled via bit 8 of the PAR (address 19h), then the DP83840A will halt all current operations and transmit the FEFI IDLE pattern when SD+/- is de-asserted following a good link indication from the Link Integrity Monitor. Transmission of the FEFI IDLE pattern will continue until SD+/- is asserted.

If three or more FEFI IDLE patterns are detected by the DP83840A, then bit 4 of the Basic Mode Status Register (address 01h) is set to one until read by management. Additionally, upon detection of Far End Fault, all receive and transmit MII activity is disabled/ignored.

This function is optional for 100BASE-FX compliance and should be disabled for 100BASE-TX compliance.

Note: The first FEFI IDLE pattern may contain more than 84 ones as the pattern may have started during IDLE transmission. Also, the FEFI IDLE pattern will not cause carrier detection.

3.4.12 Carrier Integrity Monitor

The Carrier Integrity Monitor function (CIM) protects the repeater from transient conditions that would otherwise cause spurious transmission due to a faulty link. This function is required for repeater applications and is not specified for node applications.

The REPEATER pin (pin # 47) determines the default state of bit 5 of the PCR (Carrier Integrity Monitor Disable, address 17h) to automatically enable or disable the CIM function as required for IEEE 802.3u/D5 compliant applications. After power-up/hardware reset, software may enable or disable this function independent of repeater or node/switch mode.

If the CIM determines that the link is unstable, the DP83840A will not propagate the received data or control signaling to the MII and will ignore data transmitted via the MII. The DP83840A will continue to monitor the receive stream for valid carrier events.

Detection of an unstable link condition will cause bit 5 of the PAR (address 19h) to be set to one. This bit is cleared to zero upon a read operation once a stable link condition is detected by the CIM. Upon detection of a stable link, the DP83840A will resume normal operations.

The Disconnect Counter (address 12h) increments each time the CIM determines that the link is unstable.

3.5 CLOCK GENERATION MODULE

The Clock Generation Module (CGM) within the DP83840A can be configured for several different applications. This offers the flexibility of selecting a clocking scheme that is best suited for a given design.

This section describes the operation of the CGM from both the device perspective as well as at the system level such as in an adapter or repeater. A tolerance of no greater than

50ppm is recommended for all external references driving the CGM.

It is important to note that in order to provide proper device initialization, even when operating the DP83840A in 100BASE-X only mode, the 10BASE-T sections of the device must also be provided with a clock upon device power-up/reset to ensure proper device initialization. This is taken into consideration in the following subsections.

It is also important to note that the state of the internal divide-by-two flip-flop, between OSCIN and CLK25M, is unknown at power-up/reset. Therefore, the phase of CLK25M relative to that of OSCIN can be either 0 degrees or 180 degrees.

3.5.1 Single 50 MHz Reference

This option will support 10BASE-T, 100BASE-X, or combined 10/100.

A 50 MHz oscillator can be used to drive the OSCIN input. This reference is internally divided by two and then routed to the CLK25M output pin. By connecting the CLK25M output directly to the REFIN input pin, the 25 MHz reference is allowed to drive the 100 Mb/s module. The 50 MHz signal is also divided by 2.5 internally to provide the 20 MHz reference directly to the 10 Mb/s module. This option is shown in Figure 6.

The 10BASE-T module within the DP83840A will automatically switch to the 20 MHz reference (sourced by the internal \bar{Q} .5 circuit) upon detection of inactivity on the X1 input pin. When not in use, the X1 input pin should be pulled-up to V_{CC} (4.7 k Ω pull-up resistor recommended).

It should be noted that an external 20 MHz reference driving the X1 input will provide the best over all transmit jitter performance from the integrated 10BASE-T transmitter.

3.5.2 50 MHz and 20 MHz References

This option will support 10BASE-T, 100BASE-X, or combined 10/100.

For improved jitter performance in the 10 Mb/s module, an external 20 MHz oscillator can be used to drive the X1 pin. Alternatively, a 20 MHz crystal network can be connected across pins X1 and X2 to provide the required reference for the 10 Mb/s module. The 100 Mb/s module must still receive a 25 MHz reference which can be provided by a 50 MHz oscillator as described in 3.5.1. This option is shown in Figure 7 (20 MHz oscillator module) and Figure 8 (20 MHz crystal).

3.5.3 25 MHz and 20 MHz References

This option will support 10BASE-T, 100BASE-X, or combined 10/100.

A 25 MHz reference, either from an oscillator or a system clock can directly drive the 100 Mb/s module via the REFIN input.

A separate 20 MHz reference from either an oscillator or a crystal network must be provided to the X1 and X2 inputs as described in 3.5.2. This option is shown in Figure 9.

Because the CLK25M output is not used with this clocking scheme, it is recommended that it be disabled by setting bit 7 of the PCS Configuration Register (PCR address 17h).

3.0 Functional Description (Continued)

3.5.4 Single 25 MHz Reference

This option will support only 100BASE-X as might be required in 100BASE-X repeaters that do not employ Auto-Negotiation. 10BASE-T and Auto-Negotiation will not function when using this clocking scheme.

A 25 MHz reference, either from an oscillator or a system clock can directly drive the 100 Mb/s module via the REFIN input.

The same 25 MHz reference must be also be connected to the OSCIN input in order to meet the requirement for the presence of a clock in the 10BASE-T module to ensure proper device initialization upon power-up/reset. Even though the divide by 2.5 of the 25MHz clock does not yield the typical 20MHz 10BASE-T reference, it is still sufficient for device initialization purposes. This option is shown in Figure 10.

Because the CLK25M output is not used with this clocking scheme, it is recommended that it be disabled by setting bit7 of the PCS Configuration Register (PCR address 17h).

3.5.5 System Clocking

The DP83840A clock options help to simplify single port adapter designs as well as multi-port repeaters. The TX_CLK allows 10 Mb/s MII data to be received in either

parallel or serial modes as described in Section 3.1.3. The standard MII interface clock rate options are as follows:

TX_CLK = 25 MHz for 100 Mb/s nibble mode

TX_CLK = 2.5 MHz for 10 Mb/s nibble mode

Additionally, the DP83840A provides:

TX_CLK = 10 MHz for 10 Mb/s serial mode

3.5.5.1 Adapter Clock Distribution Example

In most single port adapter applications, where only one DP83840A is required, providing a single 50 MHz oscillator reference is sufficient for deriving the required MAC and PHY layer clocks as illustrated in Figure 11. Based on the 50 MHz reference, the DP83840A can generate its own internal 20 MHz reference for the 10 Mb/s module. Additionally, the DP83840A can generate the required 25 MHz reference for its 100 Mb/s module.

During 100 Mb/s operation the 25 MHz reference generated by the DP83840A is available at the TX_CLK output pin. This can be used for synchronization with the MAC layer device. During 10 Mb/s operation the TX_CLK pin sources either a 2.5 MHz or 10 MHz reference to the MAC layer device. Figure 10 provides an example of the clock distribution in a typical node design based on the DP83840A.

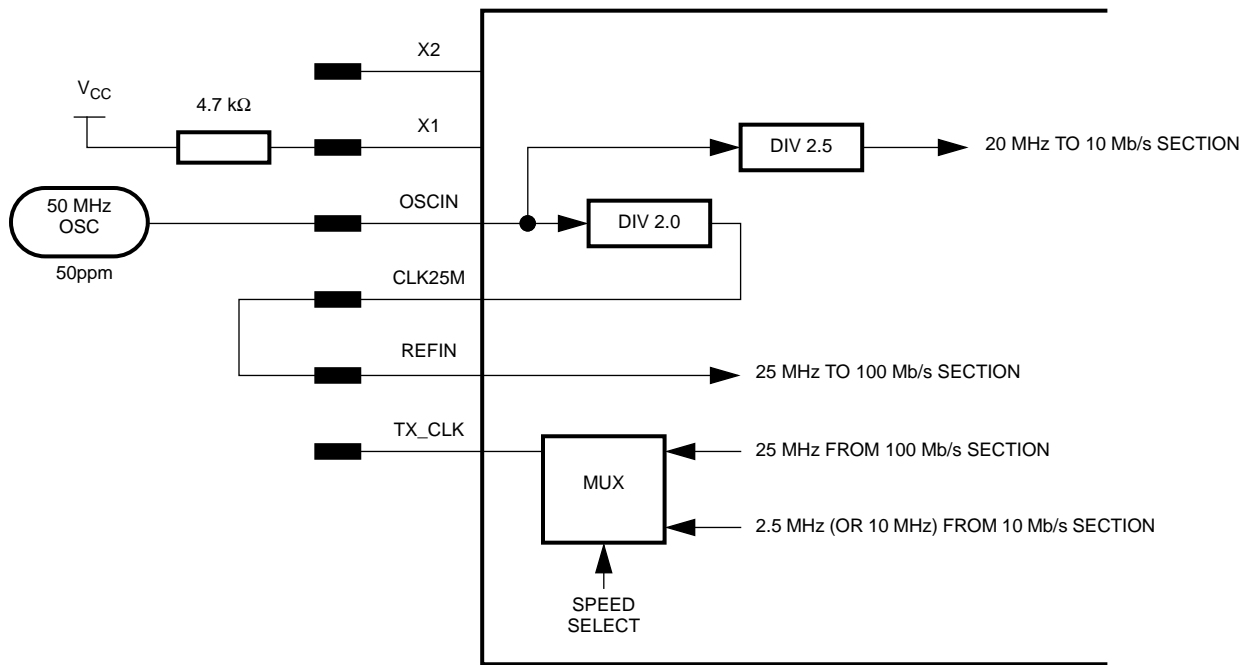

FIGURE 6. Single 50 MHz Reference

3.0 Functional Description (Continued)

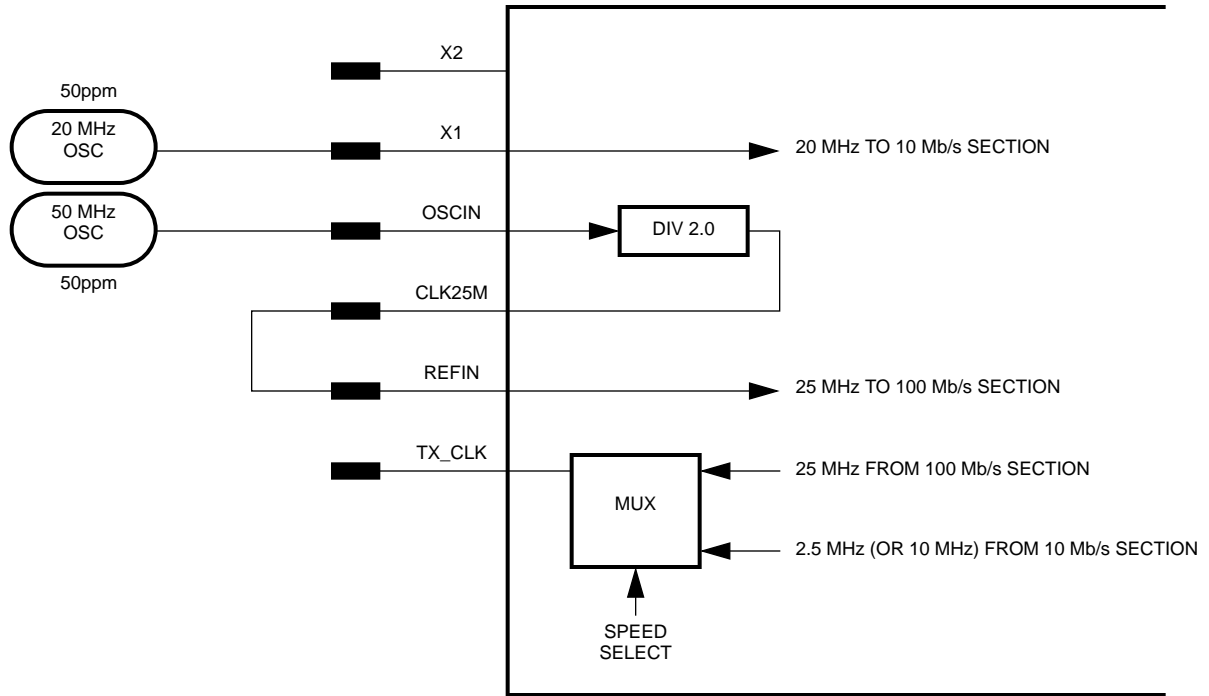
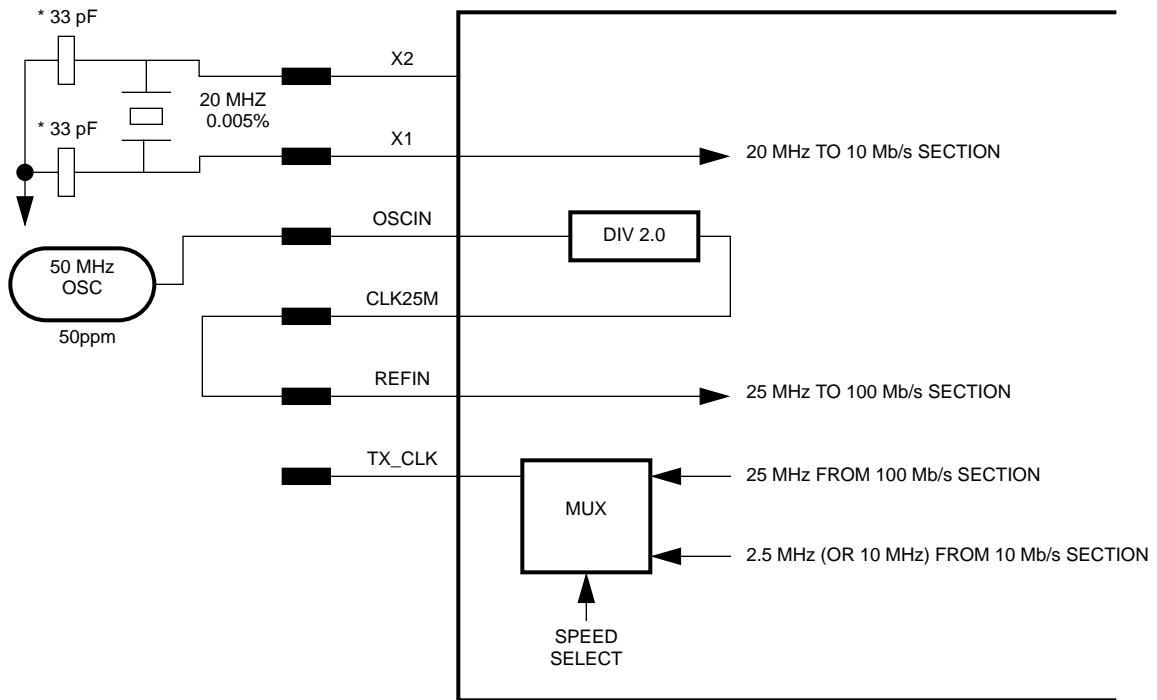

FIGURE 7. 50 MHz and 20 MHz References



* NOTE: REFER TO CRYSTAL MANUFACTURE FOR RECOMMENDED CRYSTAL LOAD CAPACITANCE

FIGURE 8. 50 MHz Reference and 20 MHz Crystal

3.0 Functional Description (Continued)

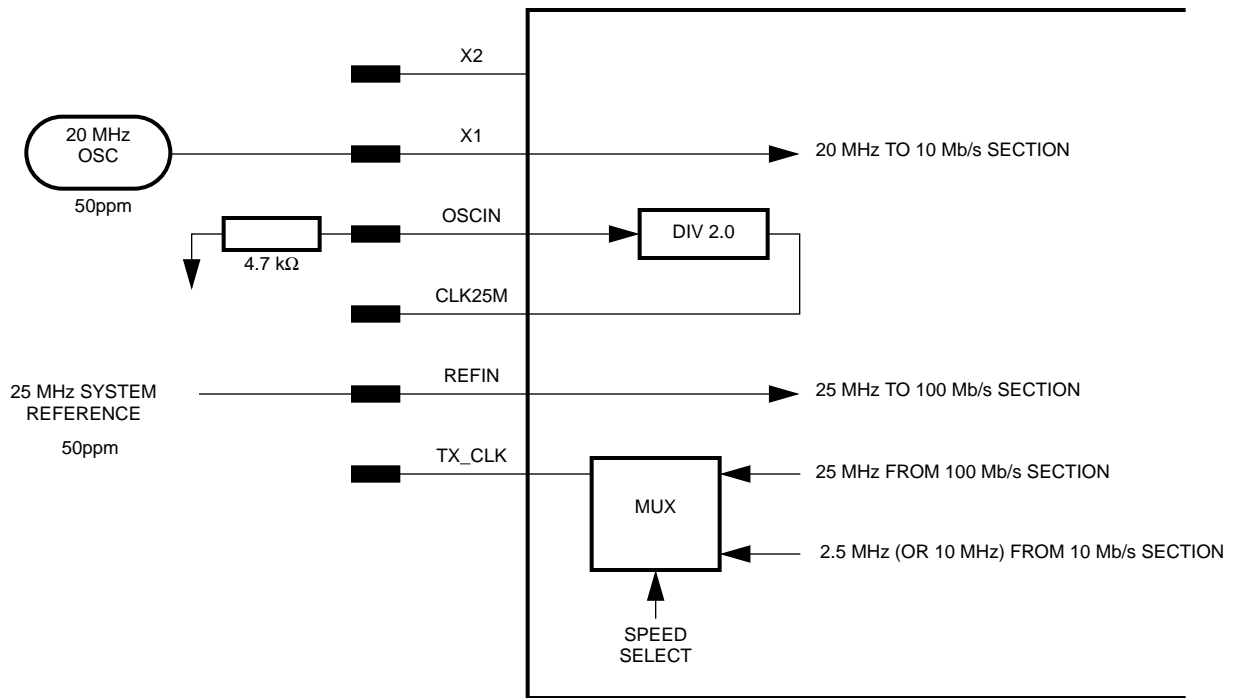

FIGURE 9. 25 MHz and 20 MHz References

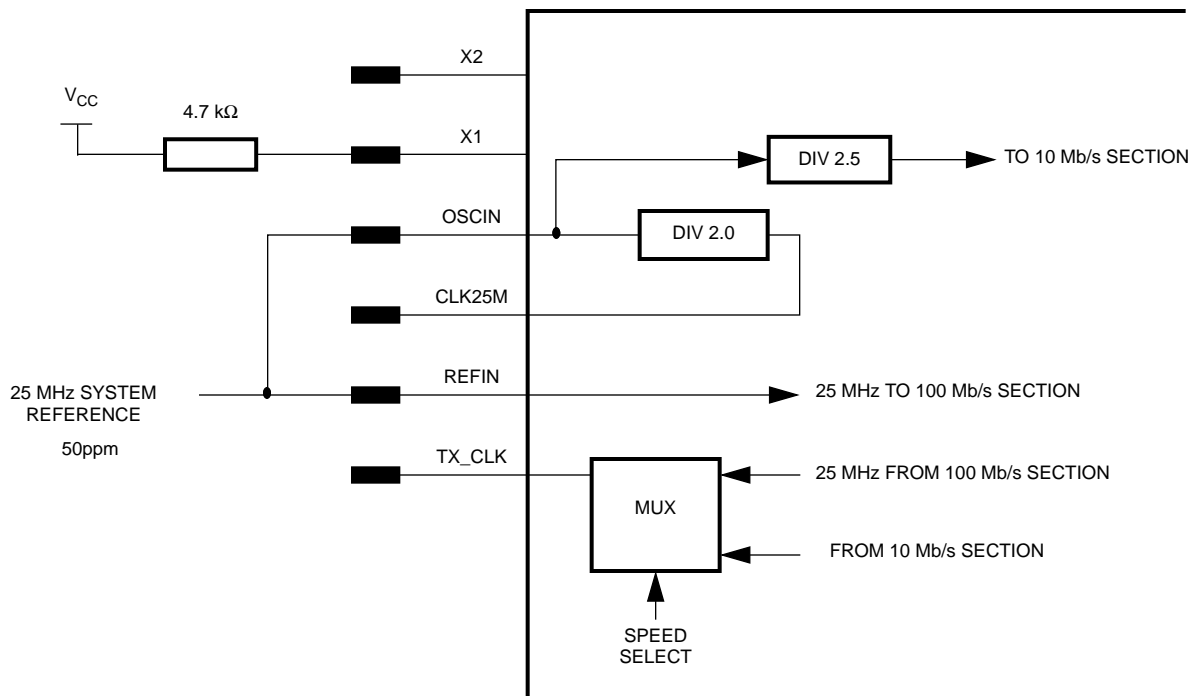

FIGURE 10. Single 25 MHz Reference

3.0 Functional Description (Continued)

3.5.5.2 Repeater Clock Distribution Example

The clock distribution within a multi-port repeater can be designed in a variety of ways. Figure 12 provides a simplified example of one possible timing distribution scheme in a 100 Mb/s only repeater design. It should be noted that in order to support Auto-Negotiation, a 20 MHz reference would be required for each DP83840A device.

Due to the demanding timing constraints required to maintain standards compliance, great care must be taken in the design and layout of a multi-port repeater system. The example provided in Figure 12 illustrates interconnection only and should not be considered as a reference design.

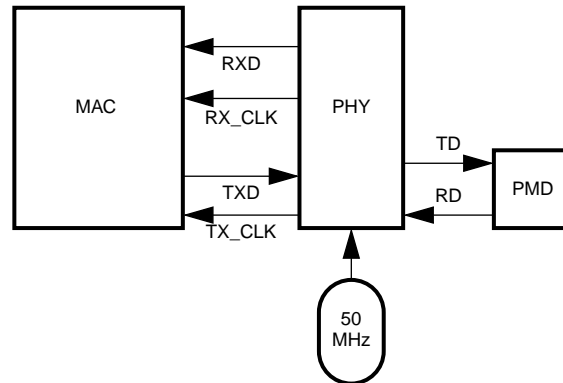

FIGURE 11. Typical Adapter Clock and Data Typical

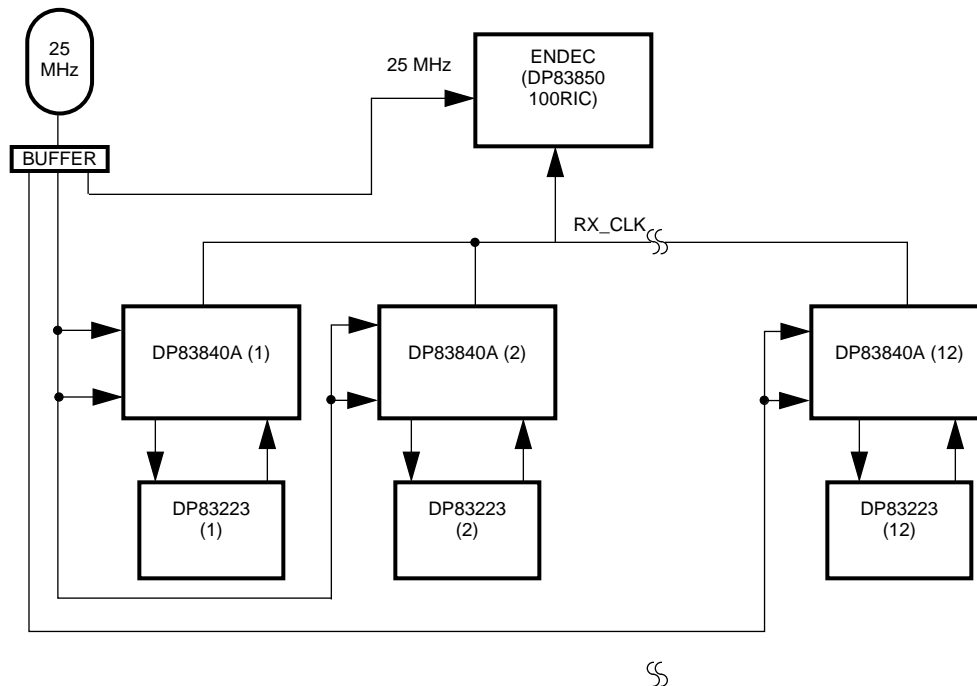

FIGURE 12. Typical 100 Mb/s Repeater Clock Interconnection

3.0 Functional Description (Continued)

3.6 CLOCK RECOVERY MODULE

The Clock Recovery Module (CRM) is part of the 100 Mb/s receive channel. The 10 Mb/s clock recovery is independent from the CRM.

The CRM contains a Phase Locked Loop that tracks the signal frequency of the incoming 125 Mb/s data stream at the RD+/- inputs. The CRM extracts a synchronous 125 MHz clock from this data (the data rate on the cable is 125 Mb/s due to 4B5B encoding). The CRM obtains its initial frequency and stability from its own internal VCO and then adjusts the frequency as required to match the incoming data stream frequency. The CRM maintains control of the PLL's loop gain to minimize the lock time as well as to minimize the jitter after phase lock has been acquired.

When the Signal Detect (SD+/-) inputs become active, the CRM attempts to acquire lock. Upon the deassertion of Signal Detect, the CRM remains locked to the frequency of the most recent datastream that it had locked to prior to SD deassertion.

The CRM generates a 125 MHz clock synchronous with the receive data stream and presents both the clock and data to the rest of the 100 Mb/s receive section. The CRM is not synchronous with the local clock present at the REFIN input to the CGM.

The RX_CLK signal at the MII interface is derived from the CRM 125 Mb/s clock during 100 Mb/s operation. The RX_CLK frequency is set to 25 MHz for nibble-wide receive data passing to the MAC and/or Repeater.

3.7 10BASE-T TRANSCEIVER MODULE

The 10BASE-T Transceiver Module is IEEE 802.3 compliant. It includes the receiver, transmitter, collision, heartbeat, loopback, jabber, and link integrity functions, as defined in the standard. An external filter is not required on the 10BASE-T interface since this is integrated inside the DP83840A. Figure 13 provides a detailed block level representation of the complete 10BASE-T transceiver within the DP83840A. Due to the complexity and scope of the 10BASE-T Transceiver block and various sub-blocks, this section focuses on the general system level operation.

3.7.1 Operational Modes

The DP83840A has 2 basic 10 Mb/s operational modes:

- Half Duplex mode
- Full Duplex mode

3.7.1.1 Half Duplex Mode

In Half Duplex mode the DP83840A functions as a standard IEEE 802.3 10BASE-T transceiver with fully integrated filtering for both the transmit and receive 10BASE-T signaling (refer to section 3.7).

3.7.1.2 Full Duplex Mode

In Full Duplex mode the DP83840A is capable of simultaneously transmitting and receiving without asserting the collision signal. The DP83840A's 10 Mb/s ENDEC is designed to encode and decode simultaneously.

3.7.2 Oscillator Module Operation

A 20MHz crystal or can-oscillator with the following specifications is recommended for driving the X1 input.

1. TTL or CMOS output with a 50ppm frequency tolerance
2. 40-60% duty cycle (max).
3. Two TTL load output drive

The circuit is shown in Figure 15. Additional output drive may be necessary if the oscillator must also drive other components. When using a clock oscillator it is still recommended that the designer connect the oscillator output to the X1(OSCIN) pin and leave X2(OSCOUT) floating

3.7.3 Smart Squelch

The Smart Squelch is responsible for determining when valid data is present on the differential receive inputs (RXI). The DP83840A implements an intelligent receive squelch on the RXI differential inputs to ensure that impulse noise on the receive inputs will not be mistaken for a valid signal. Smart squelch operation is independent of the 10BASE-T operational mode.

The squelch circuitry employs a combination of amplitude and timing measurements (as specified in the IEEE 802.3 10BASE-T standard) to determine the validity of data on the twisted pair inputs (refer to figure 14).

The signal at the start of packet is checked by the smart squelch and any pulses not exceeding the squelch level (either positive or negative, depending upon polarity) will be rejected. Once this first squelch level is overcome correctly the opposite squelch level must then be exceeded within 150ns. Finally the signal must exceed the original squelch level within a further 150ns to ensure that the input waveform will not be rejected. The checking procedure results in the loss of typically three bits at the beginning of each packet.

Only after all these conditions have been satisfied will a control signal be generated to indicate to the remainder of the circuitry that valid data is present. At this time, the smart squelch circuitry is reset.

Valid data is considered to be present until squelch level has not been generated for a time longer than 150ns, indicating End of Packet. Once good data has been detected the squelch levels are reduced to minimize the effect of noise causing premature End of Packet detection.

The receive squelch threshold level can be lowered for use in longer cable or STP applications. This is achieved by setting the LSS bit in the 10BTCR (bit 2, register address 1Ch).

3.7.4 Collision Detection

For Half Duplex, a 10BASE-T collision is detected when the receive and transmit channels are active simultaneously. Collisions are reported by the COL signal on the MII.

If the ENDEC is transmitting when a collision is detected, the collision is not reported until seven bits have been received while in the collision state. This prevents a collision being reported incorrectly due to noise on the network. The COL signal remains set for the duration of the collision.

When heartbeat is enabled, approximately 1 μ s after the transmission of each packet, a Signal Quality Error (SQE) signal of approximately 10 bit times is generated (internally) to indicate successful transmission. SQE is reported as a pulse on the COL signal of the MII.

3.7.5 Carrier Sense

Carrier Sense (CRS) may be asserted due to receive activity once valid data is detected via the Smart Squelch function.

3.0 Functional Description (Continued)

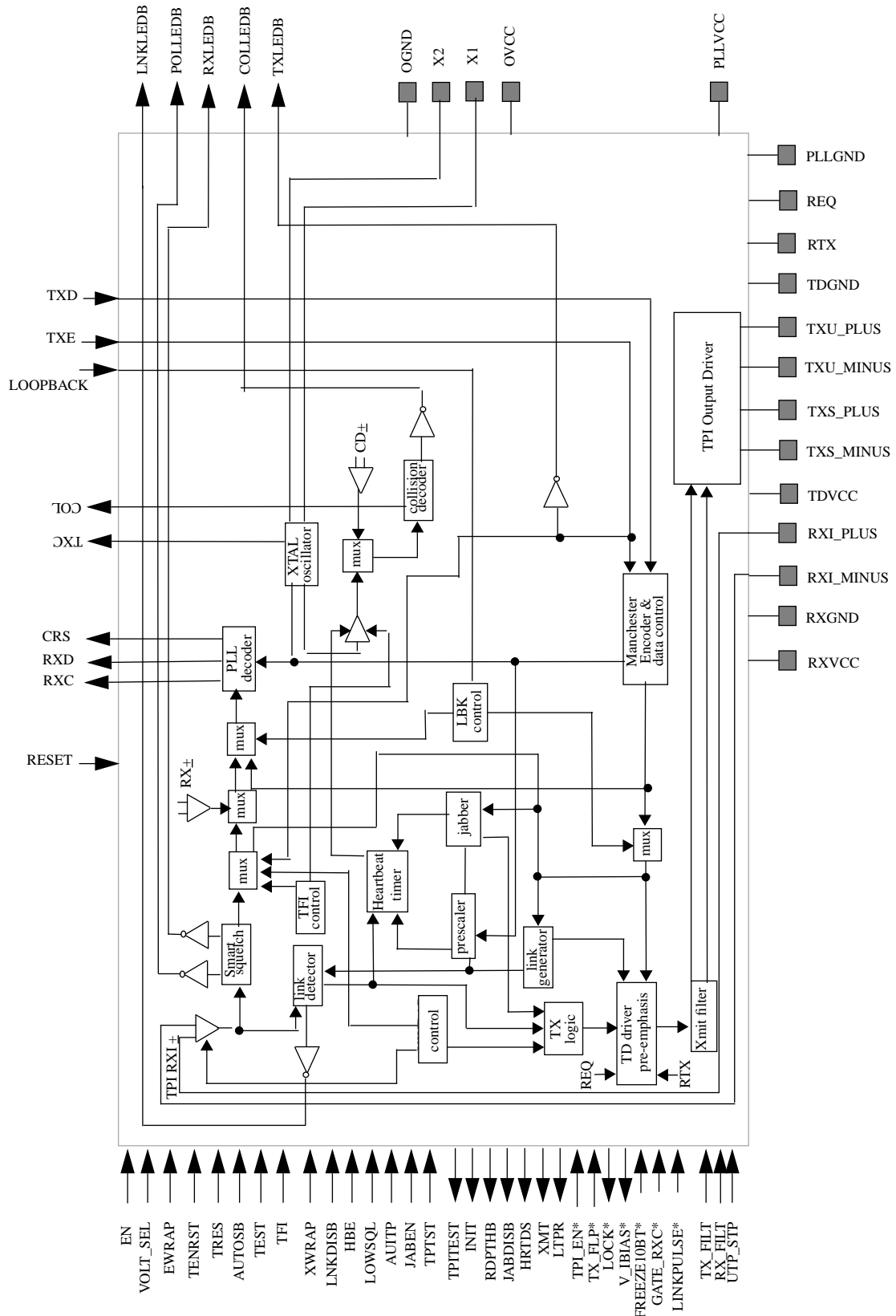

FIGURE 13. 10BASE-T Transceiver Block Diagram

3.0 Functional Description (Continued)

For 10 Mb/s Half Duplex operation, CRS is asserted during either packet transmission or reception.

For 10 Mb/s Full Duplex operation, the behavior of CRS depends on bit 6 of the LBREMR (address 18h). If this bit is zero, then CRS is asserted only due to receive activity. If this bit is one, then CRS is asserted only due to transmit activity. This operation allows flexibility for interfacing a Full Duplex MAC to the DP83840A.

CRS is deasserted following an end of packet.

In REPEATER mode (pin 47/bit 12, register address 17h), CRS is only asserted due to receive activity.

3.7.6 Normal Link Pulse Detection/Generation

The link pulse generator produces pulses as defined in the IEEE 802.3 10BASE-T standard. Each link pulse is nominally 100 ns in duration and is transmitted every 16 ms 8ms in the absence of transmit data.

Link pulse is used to check the integrity of the connection with the remote end. If valid link pulses are not received, the link detector disables the 10BASE-T twisted pair transmitter, receiver and collision detection functions.

When the link integrity function is disabled, the 10BASE-T transceiver will operate regardless of the presence of link pulses.

In 10 Mb/s ENDEC loopback mode (bit 11, register address 18h), transmission and reception paths can be tested regardless of the incoming link status.

3.7.7 Jabber Function

The Jabber function monitors the DP83840A's output and disables the transmitter if it attempts to transmit a longer than legal sized packet. A jabber timer monitors the transmitter and disables the transmission if the transmitter is active for greater than approximately 26ms.

Once disabled by the Jabber function, the transmitter stays disabled for the entire time that the ENDEC module's internal transmit enable is asserted. This signal has to be de-asserted for approximately 750ms (the "unjab" time) before the Jabber function re-enables the transmit outputs.

The Jabber function is only meaningful in 10BASE-T mode.

3.7.8 Transmit Outputs

There are two pairs of 10BASE-T output signals. One pair for Unshielded cable (TXU+/-) and one pair for Shielded cable (TXS+/-). These two sets of differential outputs are actually identical to one another. They are both included in the DP83840A for increased flexibility in multiple media designs. Note that the characteristic differential cable impedance for Unshielded cable is 100 Ohms (nominally) and for Shielded cable is 150 ohms (nominally). Therefore, special attention must be paid to the external termination resistor values in order to properly match the 10BASE-T driver impedance to the load. Refer to Figure 15 for further detail.

Selection between 100 UTP and 150 STP cable operation is accomplished using the UTP/STP bit in the 10BASE-T Configuration Register (bit 3, register address 1Ch). Only one set of outputs is active at any given time. Selecting UTP will TRI-STATE STP and vice versa.

The TXU+/- and TXS+/- outputs of the DP83840A are internally filtered and require no additional external filtering. See Section 3.7.12 for further detail.

During 100 Mb/s operation, both the TXU+/- and TXS+/- outputs are tri-stated.

3.7.9 Status Information

10BASE-T Status Information is available on the LED output pins of the DP83840A. Transmit activity, receive activity, link status, link polarity and collision activity information is output to the five LED output pins (LED1 to LED5). See Section 2.6 for more information on these outputs.

If required the LED outputs can be used to provide digital status information to external circuitry.

The Link LED output (LED3, pin #38) indicates Good Link status for both 10 and 100 Mb/s modes. In Half Duplex 10BASE-T mode, LED3 indicates link status.

The link integrity function can be disabled. When disabled, the transceiver will operate regardless of the presence of link pulses and the Link LED will stay lit continuously.

3.7.10 Automatic Link Polarity Detection

The DP83840A's 10BASE-T Transceiver Module incorporates an automatic link polarity detection circuit. When seven consecutive link pulses or three consecutive receive packets with inverted End-of-Packet pulses are received, bad polarity is reported.

A polarity reversal can be caused by a wiring error at either end of the UTP/STP cable, usually at the Main Distribution Frame (MDF) or patch panel in the wiring closet.

The bad polarity condition is latched and the LED4 output is asserted. The DP83840A's 10BASE-T Transceiver Module corrects for this error internally and will continue to decode received data correctly. This eliminates the need to correct the wiring error immediately.

3.7.11 10BASE-T Internal Loopback

When the 10BT_LPBK bit in the LBREMR (bit 11, register address 18h) is set, 10BASE-T transmit data is looped back in the ENDEC to the receive channel. The transmit drivers and receive input circuitry are disabled in transceiver loopback mode, isolating the transceiver from the network.

Loopback is used for diagnostic testing of the data path through the transceiver without transmitting on the network or being interrupted by receive traffic. This loopback function causes the data to loopback just prior to the 10BASE-T output driver buffers such that the entire transceiver path is tested.

3.7.12 Transmit and Receive Filtering

External 10BASE-T filters are not required when using the DP83840A as the required signal conditioning is integrated.

Only isolation/step-up transformers and impedance matching resistors are required for the 10BASE-T transmit and receive interface. The internal transmit filtering ensures that all the harmonics in the transmit signal are attenuated by at least 30 dB.

3.7.13 Encoder/Decoder (ENDEC) Module

The Endec Module consists of essentially four functions:

The oscillator generates the 10 MHz transmit clock signal for system timing from a 20 MHz oscillator.

3.0 Functional Description (Continued)

Twisted Pair Squelch Operation

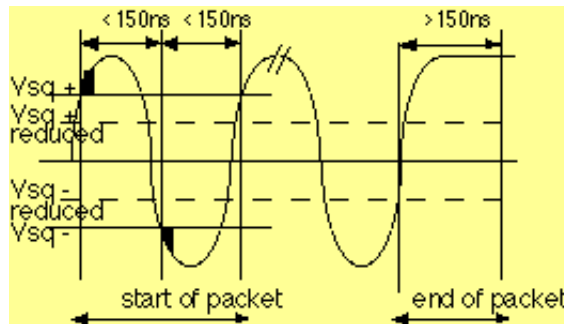

FIGURE 14. 10BASE-T Twisted Pair Smart Squelch Operation

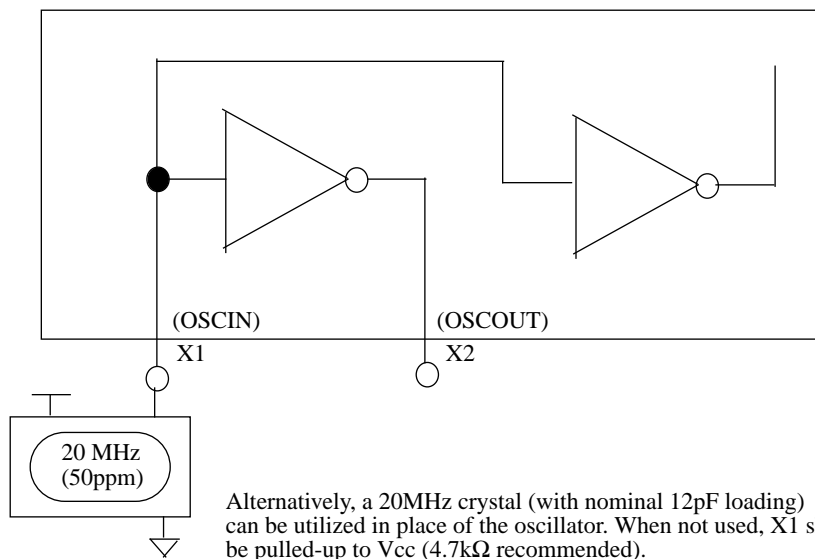

FIGURE 15. X1 and X2 Oscillator Module

3.0 Functional Description (Continued)

The Manchester encoder accepts NRZ data from the controller or repeater, encodes the data to Manchester, and transmits it differentially to the transceiver, through the differential transmit driver.

The Manchester decoder receives Manchester data from the transceiver, converts it to NRZ data and recovers clock pulses for synchronous data transfer to the controller or repeater.

The collision monitor indicates to the controller the presence of a valid 10 MHz collision signal.

3.7.13.1 Manchester Encoder and differential driver

The encoder begins operation when the Transmit Enable input (TX_EN) goes high and converts the NRZ data to pre-emphasized Manchester data for the transceiver. For the duration of TXE remaining high, the Transmit Data (TXD) is encoded for the transmit-driver pair (TXU+/- or TXS+/-). TXD must be valid on the rising edge of Transmit Clock (TxC). Transmission ends when TX_EN deasserts. The last transition is always positive; it occurs at the center of the bit cell if the last bit is a one, or at the end of the bit cell if the last bit is a zero.

3.7.13.2 Manchester Decoder

The decoder consists of a differential receiver and a PLL to separate a Manchester encoded data stream into internal clock signals and data. The differential input must be externally terminated with either a differential 100Ω or differential 150Ω termination network to accommodate either UTP or STP cable respectively. Refer to Figure 16 for further detail.

The decoder detects the end of a frame when no more mid-bit transitions are detected. Within one and a half bit times after the last bit, carrier sense is de-asserted. Receive clock stays active for five more bit times after CRS goes low, to guarantee the receive timings of the controller or repeater.

3.7.14 REQ and RTX

These pins allow for the direct control of both the pre-emphasis (REQ) and the transmit amplitude (RTX) of the 10BASE-T transmit signal. These pins should normally be left floating, however, in applications where lower transmit amplitudes are required, these pins should be pulled-down to ground resistively. Conversely, for applications that require higher transmit amplitudes, these pins should be pulled-up to Vcc resistively. Figure 16 provides a simplified functional diagram.

Some experimentation is required in order to fully evaluate the extent of transmit amplitude (and corresponding pre-emphasis) variation due to the system to system variations in external components (e.g. transformers and termination networks). It is important to use the same resistor value for both RTX and REQ (pulled to the same rail) in order to allow the pre-emphasis to track the transmit amplitude.

In general terms, a value of approximately 50KΩ for these pins (either pulled-up or pulled-down) will result in a transmit amplitude (and pre-emphasis) change on the order of 5% to 10%. Again, experimentation is recommended.

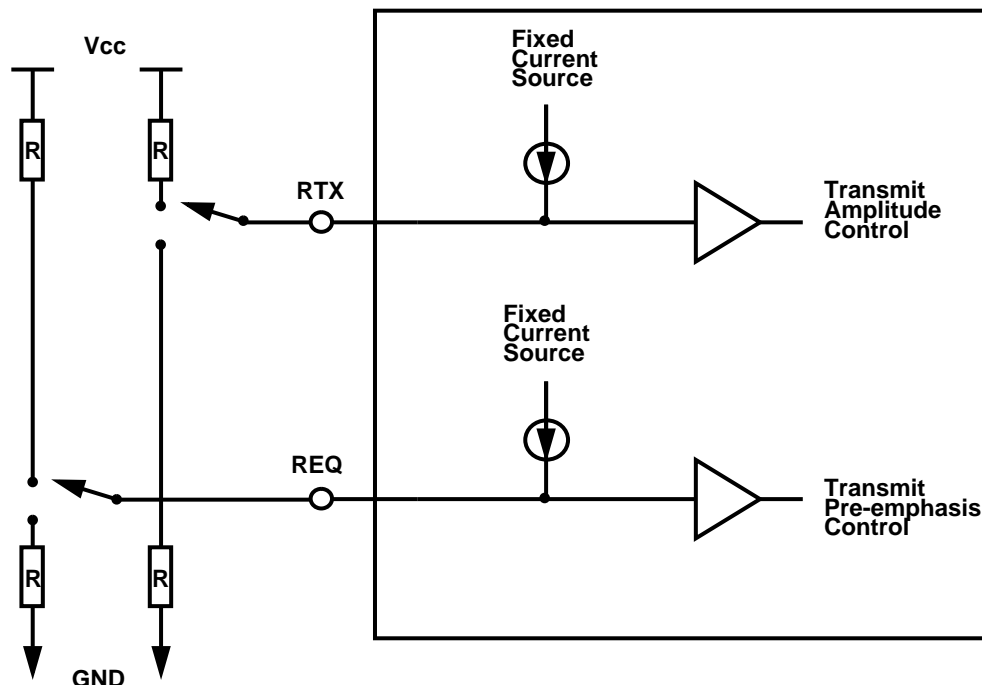

FIGURE 16. REQ and RTX Operation

3.0 Functional Description (Continued)

3.7.15 Typical Node Application

An example of the 10BASE-T interface is shown in Figure 17. The TXS+/- signals are used for STP and the TXU+/- signals for UTP. Standard UTP applications do not require connection of the TXS+/- outputs. The output resistor values are chosen to match the transmit output impedance to the impedance of the twisted pair cable.

The DP83840A 10BASE-T outputs require a 1:2 step-up isolation transformer in order to match the cable impedance. The 10BASE-T inputs require a 1:1 isolation transformer and appropriate line termination. Refer to Figure 16.

3.8 IEEE 1149.1 CONTROLLER

The IEEE 1149.1 standard defines a test access port and boundary-scan architecture for digital integrated circuits and for the digital portions of mixed analog/digital integrated circuits. Figure 18 depicts the IEEE 1149.1 architecture.

The standard provides a solution for testing assembled printed circuit boards and other products based on highly complex digital integrated circuits and high-density surface-mounting assembly techniques. It also provides a means of accessing and controlling design-for-test features built into the digital integrated circuits. Such features include internal scan paths and self-test functions as well as other features intended to support service applications in the assembled

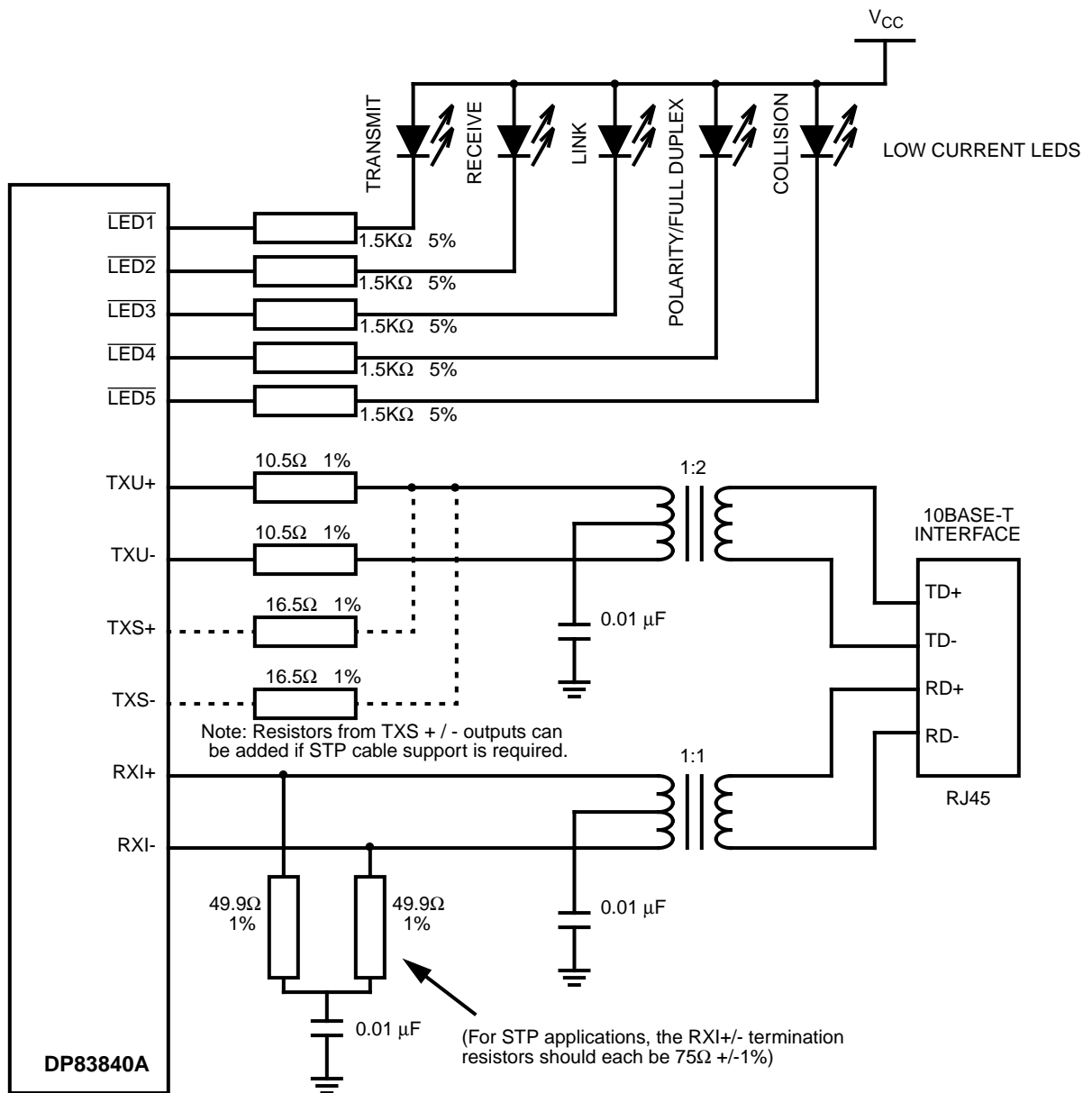

FIGURE 17. Typical 10BASE-T Node Application

3.0 Functional Description (Continued)

product. The IEEE 1149.1 Boundary Scan Architecture document should be referenced for additional detail.

The circuitry defined by this standard allows test instructions and associated data to be input serially into a device. The instruction execution results are output serially.

The DP83840A reserves five pins, called the Test Access Port (TAP), to provide test access: TMS, TCK, Test Data Input (TDI), Test Data Output (TDO) and Test Reset (TRST). These signals are described in Section 2.7. To ensure race-free operation all input and output data is synchronous to the test clock (TCK). TAP input signals (TMS and TDI) are clocked into the test logic on the rising edge of TCK while output signal (TDO) is clocked on the falling edge.

3.8.1 Test Logic

The IEEE 1149.1 Test Logic consists of a Test Access Port (TAP) controller, an instruction register, and a group of test data registers including Bypass, Device Identification and Boundary Scan registers.

The TAP controller is a synchronous 16 state machine that responds to changes at the TMS and TCK signals.

This controls the sequence of operations by generating clock and control signals to the instruction and test data registers. The control signals switch TDI and TDO between instruction and test data registers.

The DP83840A implements 4 basic instructions: ID_Code, bypass, Sample/Preload and Exttest. Upon reset, the ID_Code instruction is selected by default. If the ID_Code instruction is not supported, the bypass instruction is selected instead.

3.8.1.1 ID_Code Instruction

The ID_Code instruction allows users to select the 32-bit IDCODE register and interrogate the contents which consist of the manufacturer's ID, part ID and the version number.

3.8.1.2 Bypass Instruction

The bypass instruction uses the bypass register. The bypass register contains a single shift-register stage and is used to provide a minimum length serial path between the TDI and TDO pins of the DP83840A when test operation is not required. This allows more rapid movement of test data to and from other testable devices in the system.

3.8.1.3 Sample/Preload Instruction

The Sample/Preload instruction allows scanning of the boundary-scan register without causing interference to the normal operation of the on-chip system logic.

Two functions are performed when this instruction is selected.

Sample allows a snapshot to be taken of the data flowing from the system pins to the on-chip test logic or vice versa, without interfering with normal operation. The snapshot is taken on the rising edge of TCK in the Capture-DR controller state, and the data can be viewed by shifting through the component's TDO output.

While sampling and shifting data out through TDO for observation, preload allows an initial data pattern to be shifted in through TDI and to be placed at the latched parallel output of the boundary-scan register cells which

are connected to system output pins. This ensures that known data is driven through the system output pins upon entering the Exttest instruction.

Without Preload, indeterminate data would be driven until the first scan sequence has been completed. The shifting of data for the Sample and Preload phases can occur simultaneously. While data capture is being shifted out, the preload data can be shifted in.

3.8.1.4 Exttest Instruction

The Exttest instruction allows circuitry external to the DP83840A (typically the board interconnections) to be tested.

Prior to executing the Exttest instruction, the first test stimulus to be applied will be shifted into the boundary-scan registers using the Sample/Preload instruction. Thus, when the change to the Exttest instruction takes place, known data will be driven immediately from the DP83840A to its external connections.

This provides stimulus to the system input pins of adjacent devices on the assembled printed circuit boards. Figure 14 below illustrates the IEEE 1149.1 architecture.

3.8.2 Device Testing

IEEE 1149.1 provides a simple solution for testing many of the standard static pin parametrics. Reasonably accurate limits may be tested as a functional pattern.

The IEEE 1149.1 test circuitry is tested itself as a consequence of testing pin parametrics. Specific tests are:

- TRI-STATE conditions of TDO when serial shift between TDI and TDO is not selected

- Input leakage of TCK, TMS, TDI and TRST

- Output has TRI-STATE leakage of TDO

- Opens and shorts of TCK, TMS, TDI, TRST, and TDO

- IDCODE register, the bypass register and the TAP controller state machine sequences

Open and shorted pins can be identified by placing an alternating bit pattern

on the I/O pins. Any shorted bond wires would either cause an input to be misinterpreted in the inputs scan phase, or the test comparator would fail an output during data scan.

Repeating the test with the inverse bit pattern provides coverage of V_{CC} and GND short/open circuits.

3.8.3 Boundary Scan Description Language File

A Boundary Scan Description Language (BSDL) file is available. Contact your local National Semiconductor representative to obtain the latest version.

3.0 Functional Description (Continued)

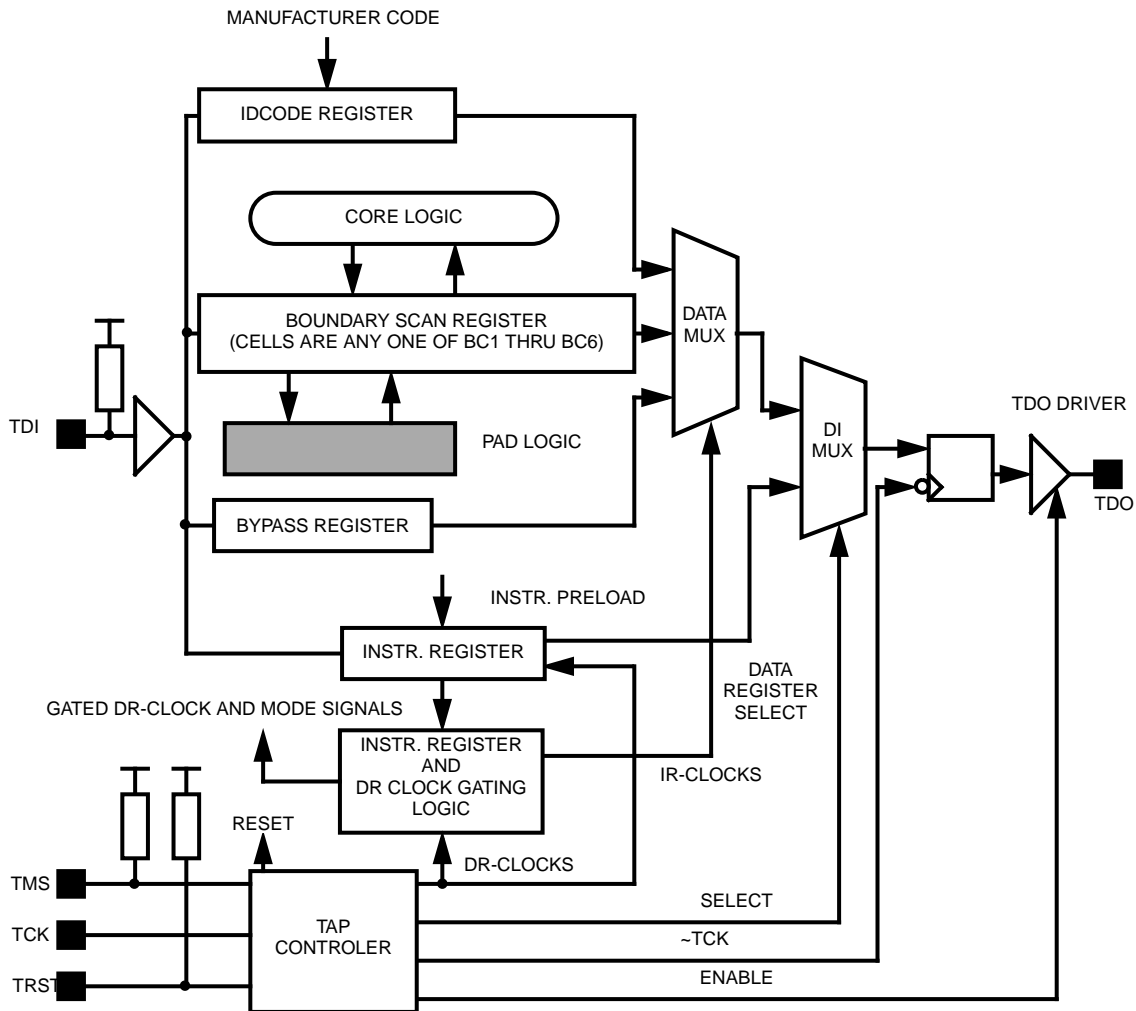

FIGURE 18. TIEEE 1149.1 Architecture

3.0 Functional Description (Continued)

3.9 IEEE 802.3u AUTO-NEGOTIATION

The Auto-Negotiation function provides a mechanism for exchanging configuration information between two ends of a link segment and automatically selecting the highest performance mode of operation supported by both devices. Fast Link Pulses (FLP) Bursts provide the signaling used to communicate Auto-Negotiation abilities between two devices at each end of a link segment. For further detail regarding Auto-Negotiation, refer to clause 28 of the IEEE 802.3u specification. The DP83840A supports four different Ethernet protocols (10 Mb/s Half Duplex, 10 Mb/s Full Duplex, 100 Mb/s Half Duplex, and 100 Mb/s Full Duplex), so the inclusion of Auto-Negotiation ensures that the highest performance protocol will be selected based on the ability of the Link Partner. The Auto-Negotiation function within the DP83840A can be controlled either by internal register access or by use of the AN1 and AN0 (pins 46 and 95.)

3.9.1 Auto-Negotiation Pin Control

The state of AN0 and AN1 determines whether the DP83840A is forced into a specific mode or Auto-Negotiation will advertise a specific ability or set of abilities as given in Table III. Pins AN0 and AN1 are implemented as quad-state control pins which are configured by connecting them to VCC, GND, a continuous 25 MHz clock, or by leaving them unconnected (refer to Figure 18) and allow configuration options to be selected without requiring internal register access. Due to the nature of these inputs, using the clock option requires the use of a CMOS logic level clock signal (high within 10% of V_{CC}). Additionally, it is recommended that, when using the clock option, the continuous 25MHz clock be buffered before driving either AN0 or AN1 as these inputs are not typical high impedance CMOS input structures.

The state of AN0 and AN1 determines the state of PAR bits 6, 7, & 10 as well as ANAR bits 5 to 8 upon power-up or hardware reset.

Upon software reset the DP83840A uses default register values, which enables Auto-Negotiation and advertises the full set of abilities (10 Mb/s Half Duplex, 10 Mb/s Full Duplex, 100 Mb/s Half Duplex, and 100 Mb/s Full Duplex) unless subsequent software accesses modify the mode.

The status Auto-Negotiation as a function of hardware configuration via the AN0 and AN1 pins is not reflected in the BMCR. It is reflected in bit 10 of the Physical Address Register (see 3.9.2 Auto-Negotiation Register Control for details.)

The Auto-Negotiation function selected at power-up or hardware reset can be changed at any time by writing to the Basic Mode Control Register (BMCR) at address 00h.

3.9.2 Auto-Negotiation Register Control

When Auto-Negotiation is enabled, the DP83840A transmits the abilities programmed into the Auto-Negotiation Advertisement Register (ANAR) at address 04h via FLP Bursts. Any combination of 10 Mb/s, 100 Mb/s, Half-Duplex, and Full Duplex modes may be selected. The default setting of bits 5 to 8 in the ANAR and bits 10, 7, & 6 in the PAR (address 19h) are determined at power-up or hard reset by the state of the AN0 and AN1 pins (see 3.9.1 Auto-Negotiation Pin Control.)

The BMCR provides software with a mechanism to control the operation of the DP83840A. However, the AN0 and

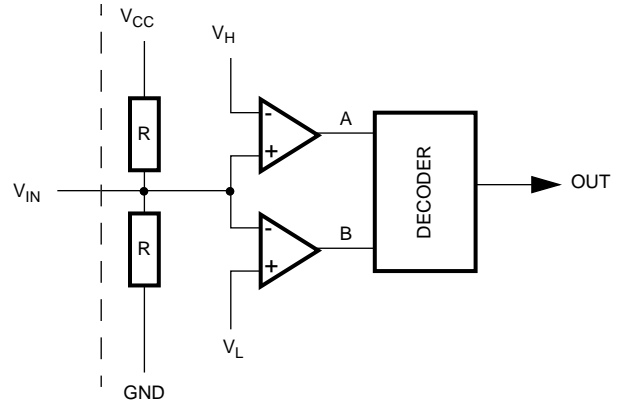

VIN	A	B	OUT
0V	L	L	L
V _{CC} /2	L	H	M
V _{CC}	H	H	H
25 MHz	25 MHz	25 MHz	C

FIGURE 19. Quad-State Pin Control

AN1 pins do not affect the contents of the BMCR and cannot be used by software to obtain status of the mode selected. The status of Auto-Negotiation Enable, Duplex mode, and Speed Indication independent of configuration via Auto-Negotiation, software, or AN0 and AN1 may be obtained by reading bits 10, 7, and 6 (respectively) of the PAR (address 19h.)

Bits 6 and 7 of the PAR are valid if Auto-Negotiation is disabled or after Auto-Negotiation is complete.

The contents of the ANLPAR register are used to automatically configure to the highest performance protocol between the local and far-end ports. Software can determine which mode has been configured by Auto-Negotiation by comparing the contents of the ANAR and ANLPAR registers and then selecting the technology whose bit is set in both the ANAR and ANLPAR of highest priority relative to the following list.

Auto-Negotiation Priority Resolution:

1. 100BASE-TX Full Duplex (Highest Priority)
2. 100BASE-TX Half Duplex
3. 10BASE-T Full Duplex
4. 10BASE-T Half Duplex (Lowest Priority)

The Basic Mode Control Register (BMCR) at address 00h provides control of enabling, disabling, and restarting of the Auto-Negotiation function. When Auto-Negotiation is disabled the Speed Selection bit in the BCMR (bit 13, register address 00h) controls switching between 10 Mb/s or 100 Mb/s operation, while the Duplex Mode bit (bit 8, register address 00h) controls switching between full duplex operation and half duplex operation. The Speed Selection and Duplex Mode bits have no effect on the mode of operation when the Auto-Negotiation Enable bit (bit 12, register address 00h) is set.

3.0 Functional Description (Continued)

Table III. Auto-Negotiation Mode Select

AN1 (Pin 46)	AN0 (Pin 95)	Action	Mode
FORCED MODES			
0	M	PAR (19h) Bit 10 = 0, Bit 6 = 1, Bit 7 = 0 ANAR (04h) [8:5] = 021h	Auto-Negotiation Disabled with Only Half-Duplex 10BASE-T Forced (Note 2)
1	M	PAR (19h) Bit 10 = 0, Bit 6 = 1, Bit 7 = 1 ANAR (04h) [8:5] = 041h	Auto-Negotiation disabled with Only Full-Duplex 10BASE-T Forced (Note 2)
M	0	PAR (19h) Bit 10 = 0, Bit 6 = 0, Bit 7 = 0 ANAR (04h) [8:5] = 081h	Auto-Negotiation disabled with Only Half-Duplex 100BASE-X Forced (Note 2)
M	1	PAR (19h) Bit 10 = 0, Bit 6 = 0, Bit 7 = 1 ANAR (04h) [8:5] = 101h	Auto-Negotiation disabled with Only Full-Duplex 100BASE-X Forced (Note 2)
C	M	PAR (19h) Bit 10 = 0, Bit 6 = 0, Bit 7 = 1 ANAR (04h) [8:5] = 181h	Auto-Negotiation disabled with Only Full-Duplex 100BASE-X Forced (Default advertisement set to 100BASE-X Half-Duplex and 100BASE-X Full-Duplex)
M	C	PAR (19h) Bit 10 = 0, Bit 6 = 0, Bit 7 = 1 ANAR (04h) [8:5] = 141h	Auto-Negotiation disabled with Only Full-Duplex 100BASE-X Forced (Default advertisement set to 100BASE-X Full-Duplex and 10BASE-T Full Duplex)
C	C	PAR (19h) Bit 10 = 0, Bit 6 = 0, Bit 7 = 0 ANAR (04h) [8:5] = 0A1h	Auto-Negotiation disabled with Only Half-Duplex 100BASE-X Forced (Default advertisement set to 100BASE-X Half-Duplex and 10BASE-T Half-Duplex)
ADVERTISED MODES			
M	M	PAR (19h) Bit 10 = 1 ANAR (04h) [8:5] = 1E1h	Auto-Negotiation Enabled for All DP83840A Possible Protocols (Note 2)
0	0	PAR (19h) Bit 10 = 1 ANAR (04h) [8:5] = 021h	Auto-Negotiation Enabled with Only Half-Duplex 10BASE-T Available
0	1	PAR (19h) Bit 10 = 1 ANAR (04h) [8:5] = 041h	Auto-Negotiation Enabled with Only Full-Duplex 10BASE-T Available
1	0	PAR (19h) Bit 10 = 1 ANAR (04h) [8:5] = 081h	Auto-Negotiation Enabled with Only Half-Duplex 100BASE-X Available
1	1	PAR (19h) Bit 10 = 1 ANAR (04h) [8:5] = 101h	Auto-Negotiation Enabled with Only Full-Duplex 100BASE-X Available
C	1	PAR (19h) Bit 10 = 1 ANAR (04h) [8:5] = 141h	Auto-Negotiation Enabled with 100BASE-X Full-Duplex and 10BASE-T Full Duplex Available
C	0	PAR (19h) Bit 10 = 1 ANAR (04h) [8:5] = 0A1h	Auto-Negotiation Enabled with 100BASE-X Half-Duplex and 10BASE-T Half Duplex Available
1	C	PAR (19h) Bit 10 = 1 ANAR (04h) [8:5] = 181h	Auto-Negotiation Enabled with 100BASE-X Full-Duplex and 100BASE-X Half Duplex Available
0	C	PAR (19h) Bit 10 = 1 ANAR (04h) [8:5] = 061h	Auto-Negotiation Enabled with 10BASE-T Full-Duplex and 10BASE-T Half Duplex Available

Note 1: "M" indicates logic mid level ($V_{cc}/2$), "1" indicates logic high level, "0" indicates logic low level

Note 2: Default advertisement on enable of Auto-Negotiation via the ANAR set to 100BASE-X Full-Duplex, 100BASE-X Half-Duplex, 10BASE-T Full-Duplex, and 10BASE-T Half-Duplex)

3.0 Functional Description (Continued)

The Basic Mode Status Register (BMSR) at address 01h indicates the set of available abilities for technology types (bits 15 to 11, register address 01h), Auto-Negotiation ability (bit 3, register address 01h), and Extended Register Capability (bit 0, register address 01h). These bits are permanently set to indicate the full functionality of the DP83840A (only the 100BASE-T4 bit is not set since the DP83840A does not support that function, while it does support all the other functions).

The BMSR also provides status on:

1. Whether Auto-Negotiation is complete (bit 5, register address 01h)
2. Whether the Link Partner is advertising that a remote fault has occurred (bit 4, register address 01h)
3. Whether a valid link has been established (bit 2, register address 01h)
4. Support for Management Frame Preamble suppression (bit 6, register address 01h)

The Auto-Negotiation Advertisement Register (ANAR) at address 04h indicates the Auto-Negotiation abilities to be advertised by the DP83840A. All available abilities are transmitted by default, but any ability can be suppressed by writing to the ANAR. Updating the ANAR to suppress an ability is one way for a management agent to change (force) the technology that is used.

The Auto-Negotiation Link Partner Ability Register (ANLPAR) at address 05h indicates the abilities of the Link Partner as indicated by Auto-Negotiation communication. The contents of this register are considered valid when the Auto-Negotiation Complete bit (bit 5, register address 01h) is set.

The Auto-Negotiation Expansion Register (ANER) at address 06h indicates additional Auto-Negotiation status. The ANER provides status on:

1. Whether a Multiple Link Fault has occurred (bit 4, register address 06h)
2. Whether the Link Partner supports the Next Page function (bit 3, register address 06h)
3. Whether the DP83840A supports the Next Page function (bit 2, register address 06h). The DP83840A does not support the Next Page function.
4. Whether the current page being exchanged by Auto-Negotiation has been received (bit 1, register address 06h)
5. Whether the Link Partner supports Auto-Negotiation (bit 0, register address 06h)

3.9.3 Auto-Negotiation Parallel Detection

The DP83840A in conjunction with the DP83223 transceiver supports the Parallel Detection function as defined in the IEEE 802.3u specification. Parallel Detection requires both the 10 Mb/s and 100 Mb/s receivers to monitor the receive signal and report link status to the Auto-Negotiation function. Auto-Negotiation uses this information to configure the correct technology in the event that the Link Partner does not support Auto-Negotiation yet is transmitting link signals that the 100BASE-X or 10BASE-T PMAs recognize as valid link signals.

The Auto-Negotiation function will only accept a valid link signal for the purpose of Parallel Detection from PMAs which have a corresponding bit set in the Auto-Negotiation

Advertisement register, (ANAR register bits 5 and 7, register address 04h.) This allows the DP83840A to be configured as a 100 Mb/s only, 10 Mb/s only, or 10 Mb/s & 100 Mb/s CSMA/CD operation device depending on the advertised abilities. The state of these bits may be modified via the AN0 and AN1 pins (see 3.9.1 Auto-Negotiation Pin Control) or by writing to the ANAR. For example, if bit 5 is zero and bit 7 is one in the ANAR (i.e. 100 Mb/s CSMA/CD only), and the Link Partner is 10BASE-T without Auto-Negotiation, then Auto-Negotiation will not complete since the advertised abilities and the detected abilities have no common mode. This operation allows the DP83840A to be used in single mode (i.e. repeater) applications as well as dual mode applications (i.e. 10/100 nodes or switches.)

If the DP83840A completes Auto-Negotiation as a result of Parallel Detection, bits 5 and 7 within the ANLPAR register (register address 05h) will be set to reflect the mode of operation present in the Link Partner. Software may determine that negotiation completed via Parallel Detection by reading a zero in the Link Partner Auto-Negotiation Able bit (bit 0, register address 06h) once the Auto-Negotiation Complete bit (bit 5, register address 01h) is set. In the event that more than one more than one PMA indicates a valid link, the Multiple Link Fault bit (bit 4, register address 06h) will be set.

As an example of Parallel Detection, when the Link Partner supports 100BASE-TX but does not support Auto-Negotiation, Parallel Detection will allow the DP83840A to negotiate to 100 Mb/s Half Duplex operation by detecting a valid set of IDLEs even though no Link Code Words were exchanged through FLP Bursts. A similar process on connection to a Link Partner that supports 10BASE-T but does not support Auto-Negotiation (i.e. the majority of installed 10BASE-T connections), where the DP83840A will negotiate to 10BASE-T Half Duplex operation by detecting valid link pulses separated by 8-24 ms.

3.9.4 Auto-Negotiation Restart

Once Auto-Negotiation has completed it may be restarted at any time by setting bit 9 of the BMCR to one. If the mode configured by a successful Auto-Negotiation loses a valid link, then the Auto-Negotiation process will resume and attempt to determine the configuration for the link. This function ensures that a valid configuration is maintained if the cable becomes disconnected.

A renegotiation request from any entity, such as a management agent, will cause the DP83840A halt any transmit data and link pulse activity until the break_link_timer expires (1500ms). Consequently, the Link Partner will go into link fail and normal Auto-Negotiation resumes. The DP83840A will resume Auto-Negotiation after the break_link_timer has expired by issuing FLP (fast Link Pulse) bursts.

3.9.5 Enabling Auto-Negotiation via Software

It is important to note that if the DP83840A has been initialized upon power-up as a non-auto-negotiating device (forced technology), and it is then required that auto-negotiation of re-auto-negotiation be initiated via software, bit 12 of the Basic Mode Control Register (address 00h) must first be cleared and then set for any auto-negotiation function to take effect.

3.0 Functional Description (Continued)

3.9.6 Auto-Negotiation Complete Time

This section describes the amount of time required to complete an Auto-Negotiation cycle for the 840A. These times are defined for two cases. The first case assumes that the far end link partner does not support Auto-Negotiation and is either a fixed 10M or 100M implementation.

Timer	Min spec	Max spec	840A
break link	1200ms	1500ms	1300ms
autoneg wait	500ms	1000ms	750ms
link fail inhibit	750ms	1000ms	800ms

Total	1700-2450ms	2500-3500ms	2050-2850ms

The second case assumes that the far end link partner fully supports Auto-Negotiation:

Timer	Min spec	Max spec	840A
break link	1200ms	1500ms	1300ms
FLP bursts	104ms	312ms	200ms
link fail inhibit	750ms	1000ms	800ms

Total	1304-2054ms	1812-2812ms	1500-2300ms

Refer to chapter 28 of the IEEE 802.3u standard for a full description of the individual timers related to Auto-Negotiation.

3.10 RESET OPERATION

The DP83840A can be reset either by hardware or software. A hardware reset may be accomplished either by asserting the RESET pin (pin 44) during normal operation, or upon powering up the device. A software reset is accomplished by setting the reset bit in the Basic Mode Control Register (bit 15, address 00h).

While either the hardware or software reset can be implemented at any time after device initialization, **providing a hardware reset, as described in section 3.10.1, must be implemented upon device power-up/initialization. Omitting the hardware reset operation during the device power-up/initialization sequence can result in improper device operation.**

3.10.1 Power-up / Reset

When V_{CC} is first applied to the DP83840A it takes some amount of time for power to actually reach the nominal 5V potential. This initial power-up time can be referred to as a V_{CC} ramp when V_{CC} is "ramping" from 0V to 5V. When the initial V_{CC} ramp reaches approximately 4V, the DP83840A begins an internal reset operation which must be allowed sufficient time, relative to the assertion and deassertion of the RESET pin, to reset the device. There are two methods for guaranteeing successful reset upon device power-up.

The first method accounts for those designs that utilize a special power up circuit which, through hardware, will assert the RESET pin upon power-up. In this case, the deassertion (falling edge) of the RESET pin must not occur until at least 500 μ s after the time at which the V_{CC} ramp initially reached the 4V point.

The second method accounts for those applications which produce a reset pulse sometime after the initial power-up

of the device. In this case, it is recommended that a positive pulse, with a duration of at least 1 μ s, be applied to the RESET pin no sooner than 500 μ s after the point in time where the initial V_{CC} ramp reached 4V.

In both methods described above, it is important to note that the logic levels present at each of the hardware configuration pins of the DP83840A (see list below) are also latched into the device as a function of the reset operation (either hardware or software). These hardware configuration values are guaranteed to be latched into the DP83840A 2 μ s after the deassertion of the RESET pin.

The hardware configuration values latched into the DP83840A during the reset operation are dependent on the logic levels present at the following device pins upon power-up:

Pin #	Primary Function	Latched in at Reset
49	LBEN	PHYAD[0]
53	ENCSEL	PHYAD[1]
66	CRS	PHYAD[2]
89	PHYAD[3]	PHYAD[3]
63	RX_ER	PHYAD[4]
95	AN0	AN0
46	AN1	AN1
47	REPEATER	REPEATER
98	10BTSER	10BTSER
99	BPALIGN	BPALIGN
100	BP4B5B	BP4B5B
1	BPSCR	BPSCR

During the power-up reset operation the $\overline{\text{LED1}}$ through LED5 pins are undefined, the SPEED₁₀ pin will be asserted, and the SPEED₁₀₀ pin will be deasserted.

3.10.2 Hardware Reset

A hardware Reset is accomplished by applying a positive pulse, with a duration of at least 1 μ s, to the RESET pin of the DP83840A during normal operation. This will reset the device such that all registers will be reset to default values and the hardware configuration values will be re-latched into the device (similar to the power-up reset operation).

3.10.3 Software Reset

A software reset is accomplished by setting bit 15 of the Basic Mode Control Register (address 00h). This bit is self clearing and, when set, will return a value of "1" until the software reset operation has completed. The software reset will reset the device such that all registers will be reset to default values and the hardware configuration values will be re-latched into the device (similar to the power-up reset operation). Driver code should wait 500 μ s following a software reset before allowing further serial MII operations with the DP83840A.

3.0 Functional Description (Continued)

3.11 LOOPBACK OPERATION

The DP83840A supports several different modes of loopback operation for diagnostic purposes.

3.11.1 10BASE-T Loopback

The loopback option for 10BASE-T operation can be selected via the serial MII either by asserting the Loopback bit (bit 14) in the Basic Mode Control Register (address 00h), or by asserting the 10BT_LPBK bit (bit 11) in the Loopback, Bypass and Receiver Error Mask Register (address 18h). Asserting either of these bits will cause the 10BASE-T data present at the transmit MII data inputs to be routed through the entire 10BASE-T transceiver and back to the receive MII data outputs. During this loopback mode, the Manchester encoded 10BASE-T data will not be present at either the TXU+/- or TXS+/- serial differential outputs.

Normal 10BASE-T operation, in order to be standard compliant, also loops back the MII transmit data to the MII receive data. However, the data is also allowed to pass through the 10BASE-T transmitter and out either the TXU+/- or TXS+/- outputs as well.

3.11.2 100BASE-X Loopback

The loopback options for 100BASE-X operation can be selected by asserting the Loopback bit (bit 14) in the Basic Mode Control Register (address 00h), or by selecting the desired mode as determined by the LB[1:0] (bits 9 and 8) in the Loopback, Bypass and Receiver Error Mask Register (address 18h).

Asserting the Loopback bit (bit 14) in the Basic Mode Control Register (address 00h) will cause the same loopback of MII transmit to MII receive as described previously in the 10BASE-T loopback section, except at 25 MHz due to 100BASE-X operation.

The LB[1:0] bits (bits 9 and 8) of the LBREMR (address 18h) allow for three different modes of operation:

1. bit 9 = 0, bit 8 = 0; Normal operation without loopback
2. bit 9 = 0, bit 8 = 1; PMD loopback operation
3. bit 9 = 1, bit 8 = 0; Remote Loopback

The first mode allows normal operation without any form of loopback.

The second mode asserts the LBEN output of the DP83840A which, when connected to the LBEN input of the twisted pair transceiver (DP83223A), forces the twisted pair transceiver into loopback mode. Therefore, when the DP83840A is transmitting 100BASE-X serial data from its serial TD+/- outputs to the twisted pair transceiver, this data is immediately routed back to the RD+/- 100BASE-X serial inputs of the DP83840A device.

The third mode selects the Remote Loopback operation. In this mode, the DP83840A device serves as a "remote loopback" for the far end partner. Serial data received off the twisted pair cable is routed, via the DP83223A, into the RD+/- serial inputs of the DP83840A where it is then routed back to the TD+/- serial outputs of the DP83840A and finally launched back onto the twisted pair cable, via the DP83223A, and sent back to the far-end partner.

In each of the 100BASE-X loopback modes, except for Remote Loopback, the assertion of the loopback function

will result in a 550 μ s down-time where the 100BASE-TX descrambler must reacquire synchronization with the scrambled data stream before any valid data will appear at the receive MII RXD[3:0] outputs.

3.12 ALTERNATIVE 100BASE-X OPERATION

The DP83840A 10/100 Physical Layer device supports one standard and three alternative modes when operating at 100 Mb/s.

3.12.1 Translational (normal) Mode

The first mode is referred to as the "Translational" mode. This is the standard and most commonly used operating mode where all transmit and receive functions are enabled in order to condition the data as it flows through the Physical Layer between the MAC and cable. All of the transmit and receive blocks as depicted in Figures 4 and 5 are enabled (not bypassed).

3.12.2 Transparent Mode

The second mode is referred to as "Transparent". In this mode, the 4B/5B translators in both the transmit and receive sections are bypassed as might be required in certain repeater applications. This is accomplished either by configuring the BP4B5B pin (100) of the DP83840A to a logic high level prior to power-up/hardware reset or by setting the BP_4B5B bit (bit 14) of the LBREMR register (address 18h).

In "Transparent" mode, all remaining functional blocks within the 100BASE-X transmit and receive sections are still operational. This allows the 5B serial code-group on the twisted pair to be presented as descrambled data, without conversion to 4B, to the MII. Since the MII normally only carries a nibble wide word, the fifth bit, which is the new MSB, is carried on the RX_ER and TX_ER signals for receive and transmit operations respectively.

In the "Transparent" mode, all of the clock to data timing for both MII transmit and MII receive operations remains the same as in "Translational" mode. However, upon reception of a packet, the /J/K/ start of stream delimiter is not replaced by the /5/5/ MAC preamble nor is the /T/R/ end of stream delimiter removed from the packet before presentation to the MII receive RXD[3:0] and RX_ER outputs. Similarly, the transmit MII data TXD[3:0] and TX_ER must already have /J/K/ and /T/R/ packet delimiters in place. Therefore, the repeater controller device is responsible for receiving the packet delimiters intact as well as transmitting these delimiters intact back to the DP83840A device(s).

The receive data valid flag, RX_DV, operates the same during "Transparent" mode as it does in "Translational" mode. Additionally, Idles are passed to and from the MII as /00000/.

Finally, the "Transparent" mode of operation will operate the same when the DP83840A is in either node mode or repeater mode with the only difference being CRS functionality. As in "translational" mode, if the DP83840A is configured for repeater operation, the CRS signal will be suppressed during transmit such that only actual network collisions will be flagged.

3.12.3 Phaser Mode

The final mode of operation at 100 Mb/s is referred to as the “Phaser” mode. This mode might be used for those applications where the system design requires only the clock recovery and clock generation functions of the DP83840A. This is accomplished either by configuring the BPALIGN pin (99) of the DP83840A to a logic high level prior to power-up/hardware reset or by setting the BP_ALIGN bit (bit 12) of the LBREMR register (address 18h).

In “Phaser” mode, all of the conditioning blocks in the transmit and receive sections of the 100BASE-X section are bypassed (refer to Figures 4 and 5). Therefore, whatever 5B data is presented to the MII transmit inputs (TXD[3:0] and TX_ER) of the DP83840A is simply serialized and output to the DP83223A twisted pair transceiver to be sent out over the twisted pair cable. Similarly, the 100BASE-X serial data received at the RD+/- inputs of the DP83840A are shifted into 5-bit parallel words and presented to the MII receive outputs RXD[3:0] and RX_ER. All data, including Idles, passes through the DP83840A unaltered other than for serial/parallel conversions.

3.12.4 100BASE-FX Mode

The DP83840 will allow 100BASE-FX functionality by bypassing the scrambler and descrambler. This can be accomplished either through hardware configuration or via software.

The hardware configuration is set simply by tying the BPSCR pin (1) high with a 4.7k resistor and then cycling power or resetting the DP83840A. The software setting is accomplished by setting the BP_SCR bit (bit 13) of the LBREMR register (address 18h) via MII serial management.

3.13 Low Power Mode

The DP83840A supports two power modes of operation:

The first mode allows both the 10 Mb/s and 100 Mb/s functions of the device to be powered-up. In this mode, the DP83840A may be switched to and from 10 Mb/s and 100 Mb/s modes as desired by management or Auto-Negotiation.

The second mode is a low power mode of operation which only powers the 100 Mb/s portions of the DP83840A. Neither 10 Mb/s nor Auto-Negotiation will function in this mode. This mode is particularly useful in 100 Mb/s repeater applications that do not utilize the 10 Mb/s or Auto-Negotiation functions.

Depending on the system design parameters, setting all of the DP83840A devices within a typical 12-port 100BASE-X repeater implementation will save a total of between 500mA and 800mA for the system.

The selection between the two modes is determined by the state of the LOWPWR pin (pin 3). When LOWPWR is high, the low power mode is selected. When LOWPWR is low, full functionality of the DP83840A is available.

4.0 Registers

The MII supports up to 32 word-wide registers per addressable connected device. The DP83840A's register allocation is as shown below. Each register is described in the Sections 4.2 to 4.17 that follow. Section 3.2 describes the MII serial access control method.

Address	Register Name	Description
00h	BMCR	Basic Mode Control Register
01h	BMSR	Basic Mode Status Register
02h	PHYIDR1	PHY Identifier Register #1
03h	PHYIDR2	PHY Identifier Register #2
04h	ANAR	Auto-Negotiation Advertisement Register
05h	ANLPAR	Auto-Negotiation Link Partner Ability Register
06h	ANER	Auto-Negotiation Expansion Register
07h-0Fh	Reserved	Reserved for Future Assignments by the MII Working Group
10h-11h	Reserved	Reserved for PHY Specific Future Assignments by Vendor
12h	DCR	Disconnect Counter Register
13h	FCSCR	False Carrier Sense Counter Register
14h	Reserved	Reserved--Do Not Read/Write to this Register
15h	RECR	Receive Error Counter Register
16h	SRR	Silicon Revision Register
17h	PCR	PCS Sub-Layer Configuration Register
18h	LBREMR	Loopback, Bypass and Receiver Error Mask Register
19h	PAR	PHY Address Register
1Ah	Reserved	Reserved for PHY Specific Future Assignment by Vendor
1Bh	10BTSR	10BASE-T Status Register
1Ch	10BTCR	10BASE-T Configuration Register
1Dh-1Fh	Reserved	Reserved for Future Use--Do Not Read/Write to These Registers

4.1 KEY TO DEFAULTS

In the register descriptions that follow, the default column takes the form

<reset value>, <access type>/<attribute(s)>

Where:

<reset value>:

1	Bit Set to Logic One
0	Bit Set to Logic Zero
X	No Default Value
(Pin #)	Value Latched in from Pin # at Reset

<access type>:

RO = Read Only
RW = Read/Write

<attribute(s)>:

L = Latching
SC = Self Clearing
P = Value Permanently Set

4.0 Registers (Continued)

4.2 BASIC MODE CONTROL REGISTER (BMCR)

Address 00h

Bit	Bit Name	Default	Description
15	Reset	0, RW/SC	<p>RESET:</p> <p>1 = Software Reset 0 = Normal Operation</p> <p>This bit sets the status and control registers of the PHY to their default states. Setting this bit will also re-latch in all hardware configuration pin values. This bit, which is self-clearing, returns a value of one until the reset process is complete. Software should wait 500μs after device power on before attempting a software reset. Refer to section 3.10.3 for further detail.</p>
14	Loopback	0, RW	<p>LOOPBACK:</p> <p>1 = Loopback Enabled 0 = Normal Operation</p> <p>The loopback function enables MII transmit data to be routed to the MII receive data path. When set, this bit enables loopback for either 10BASE-T or 100BASE-X modes of operation.</p> <p>Setting this bit during 100BASE-TX operation may cause the DP83840A to enter a 550 μs "dead time" before any valid data transmit or receive operations can commence.</p> <p>This bit takes priority over the loopback control bits 8 and 9 in the LBREMR register (address 18h).</p>
13	Speed Selection	1, RW	<p>SPEED SELECT:</p> <p>1 = 100 Mb/s 0 = 10 Mb/s</p> <p>Link speed is selected by this bit or by Auto-Negotiation if bit 12 of this register is set (in which case, the value of this bit is ignored). The latched-in state of pins AN0 and AN1 will also effect the state of this bit and take precedence over the Auto-Negotiation Enable bit 12.</p>
12	Auto-Negotiation Enable	1, RW	<p>AUTO-NEGOTIATION ENABLE:</p> <p>1 = Auto-Negotiation Enabled--bits 8 and 13 of this register are ignored when this bit is set. 0 = Auto-Negotiation Disabled--bits 8 and 13 determine the link speed and mode.</p> <p>If the PHY is configured for non-Auto-Negotiation upon power-up/reset and it is then decided that Auto-Negotiation is to be enabled through software, this bit must first be cleared and then set in order for it to take effect. This bit is intended only to control the state of Auto-Negotiation and should not be regarded as status. Refer to section 3.9.2 for further detail.</p>
11	Reserved	0, RW	<p>RESERVED:</p> <p>Write as 0, read as don't care.</p>

4.0 Registers (Continued)

4.2 BASIC MODE CONTROL REGISTER (BMCR) (Continued)

Address 00h

Bit	Bit Name	Default	Description
10	Isolate	(PHYAD = 00000), RW	<p>ISOLATE:</p> <p>1 = Isolates the DP83840A from the MII with the exception of the serial management. When this bit is asserted, the DP83840A does not respond to TXD[3:0], TX_EN, and TX_ER inputs, and it presents a high impedance on its TX_CLK, RX_CLK, RX_DV, RX_ER, RXD[3:0], COL and CRS outputs. The CLK_25M output stays active (if enabled) and the DP83840A still responds to serial management transactions. During Isolate mode TX_EN has no effect, TD+/- will transmit Idles, TXU+/- and TXS+/- will tri-state, transitions on the receive inputs RD +/- and RXI +/- are ignored, and link is disabled.</p> <p>0 = Normal Operation</p> <p>If the PHY Address is set to 00000 the Isolate bit will be set upon power-up/reset. Refer to section 3.2.4 for further detail.</p>
9	Restart Auto-Negotiation	0, RW/SC	<p>RESTART AUTO-NEGOTIATION:</p> <p>1 = Restart Auto-Negotiation. Re-initiates the Auto-Negotiation process. If Auto-Negotiation is disabled (bit 12 of this register cleared), this bit has no function. This bit is self-clearing and will return a value of 1 until Auto-Negotiation is initiated by the DP83840A, whereupon it will self-clear. Operation of the Auto-Negotiation process is not affected by the management entity clearing this bit.</p> <p>0 = Normal Operation</p> <p>Refer to section 3.9.4 for further detail.</p>
8	Duplex Mode	1, RW	<p>DUPLEX MODE:</p> <p>1 = Full Duplex operation. Duplex selection is allowed when Auto-Negotiation is disabled (bit 12 of this register is cleared). When Auto-Negotiation is enabled, the duplex capability as specified in bits [15:11] of the BMSR register (address 1h) reflect the current status. This bit does not reflect duplex status.</p> <p>0 = Half Duplex Operation</p>
7	Collision Test	0, RW	<p>COLLISION TEST:</p> <p>1 = Collision Test enabled. When set, this bit will cause the COL signal to be asserted in response to the assertion of TX_EN.</p> <p>0 = Normal Operation</p>
6:0	Reserved	X, RO	RESERVED: Write as 0, read as don't care.

4.3 BASIC MODE STATUS REGISTER (BMSR)

Address 01h

Bit	Bit Name	Default	Description
15	100BASE-T4	0, RO/P	<p>100BASE-T4 CAPABLE:</p> <p>1 = DP83840A able to perform in 100BASE-T4 mode</p> <p>0 = DP83840A not able to perform in 100BASE-T4 mode</p>
14	100BASE-TX Full Duplex	1, RO/P	<p>100BASE-TX FULL DUPLEX CAPABLE:</p> <p>1 = DP83840A able to perform 100BASE-TX in full duplex mode</p> <p>0 = DP83840A not able to perform 100BASE-TX in full duplex mode</p>
13	100BASE-TX Half Duplex	1, RO/P	<p>100BASE-TX HALF DUPLEX CAPABLE:</p> <p>1 = DP83840A able to perform 100BASE-TX in half duplex mode</p> <p>0 = DP83840A not able to perform 100BASE-TX in half duplex mode</p>

4.0 Registers (Continued)**4.3 BASIC MODE STATUS REGISTER (BMSR) (Continued)**

Address 01h

Bit	Bit Name	Default	Description
12	10BASE-T Full Duplex	1, RO/P	10BASE-T FULL DUPLEX CAPABLE: 1 = DP83840A able to perform 10BASE-T in full duplex mode 0 = DP83840A not able to perform 10BASE-T in full duplex mode
11	10BASE-T Half Duplex	1, RO/P	10BASE-T HALF DUPLEX CAPABLE: 1 = DP83840A able to perform 10BASE-T in half duplex mode 0 = DP83840A not able to perform 10BASE-T in half duplex mode
10:7	Reserved	0, RO	RESERVED: Write as 0, read as don't care.
6	MF Preamble Suppression	1, RO/P	Management Frame Preamble Suppression: 1 = DP83840A responds to management transactions without preamble. 0 = DP83840A requires preamble with all management transactions. A minimum of 32 preamble bits are required following power-on/hardware reset. One Idle bit is required between management transactions as per IEEE 802.3u specification. Refer to section 3.2.1.1 for further detail.
5	Auto-Negotiation Complete	0, RO	AUTO-NEGOTIATION COMPLETE: 1 = Auto-Negotiation process complete 0 = Auto-Negotiation process not complete
4	Remote Fault	0, RO/L	REMOTE FAULT: 1 = Remote Fault condition detected (cleared on read or by a chip reset). This bit is set if the RF bit in the ANLPAR (bit 13, register address 05h) is set or the receive channel meets the Far End Fault Indication function criteria (See Section 3.4.11). 0 = No remote fault condition detected
3	Auto-Negotiation Ability	1, RO/P	AUTO CONFIGURATION ABILITY: 1 = DP83840A is able to perform Auto-Negotiation 0 = DP83840A is not able to perform Auto-Negotiation
2	Link Status	0, RO/L	LINK STATUS: 1 = Valid link established (for either 10 Mb/s or 100 Mb/s operation) 0 = Link not established This bit reflects the current state of the Link-Test-Fail state machine within the DP83840A which determines the presence of either valid 100BASE-X or 10BASE-T receive signaling. With valid link, both transmit and receive functions operate normally. With no link established, the transmit and receive channels, for 100BASE-X and 10BASE-T, will not respond to transmit or receive data. However, either link pulses or Idles (depending on which speed the DP83840A is configured for) will be sourced onto the network. The link status bit is implemented with a latching function, so that the occurrence of a link failure condition causes the Link Status bit to become cleared and remain cleared until it is read via the management interface.
1	Jabber Detect	0, RO/L	JABBER DETECT: 1 = Jabber condition detected 0 = No Jabber This bit is implemented with a latching function so that the occurrence of a jabber condition causes it to become set until it is cleared by a read to this register by the management interface or by a DP83840A reset. This bit only has meaning in 10 Mb/s mode.

4.0 Registers (Continued)

4.3 BASIC MODE STATUS REGISTER (BMSR) (Continued)

Address 01h

Bit	Bit Name	Default	Description
0	Extended Capability	1, RO/P	EXTENDED CAPABILITY: 1 = Extended register capable 0 = Basic register capable only

4.4 PHY IDENTIFIER REGISTER #1 (PHYIDR1)

Address 02h

The PHY Identifier Registers #1 and #2 together form a unique identifier for the DP83840A. The Identifier consists of a concatenation of the Organizationally Unique Identifier (OUI), the vendor's model number and the model revision number. A PHY may return a value of zero in each of the 32 bits of the PHY Identifier if desired. The PHY Identifier is intended to support network management.

National Semiconductor's IEEE assigned OUI is 080017h.

Bit	Bit Name	Default	Description
15:0	OUI_MSB	<00 1000 0000 0000 00>, RO/P	OUI MOST SIGNIFICANT BITS: This register stores bits 3 to 18 of the OUI (080017h) to bits 15 to 0 of this register respectively. The most significant two bits of the OUI are ignored (the IEEE standard refers to these as bits 1 and 2).

4.5 PHY IDENTIFIER REGISTER #2 (PHYIDR2)

Address 03h

Bit	Bit Name	Default	Description
15:10	OUI_LSB	<01 0111>, RO/P	OUI LEAST SIGNIFICANT BITS: Bits 19 to 24 of the OUI (080017h) are mapped to bits 15 to 10 of this register respectively.
9:4	VNDR_MDL	<00 0000>, RO/P	VENDOR MODEL NUMBER: Six bits of vendor model number mapped to bits 9 to 4 (most significant bit to bit 9).
3:0	MDL_REV	<0001>, RO/P	MODEL REVISION NUMBER: Four bits of vendor model revision number mapped to bits 3 to 0 (most significant bit to bit 3). This field will be incremented for all major DP83840A device changes.

4.0 Registers (Continued)**4.6 AUTO-NEGOTIATION ADVERTISEMENT REGISTER (ANAR)**

Address 04h

This register contains the advertised abilities of this DP83840A device as they will be transmitted to its Link Partner during Auto-Negotiation.

Bit	Bit Name	Default	Description
15	NP	0, RO/P	NEXT PAGE INDICATION: 0 = Not Next Page able 1 = Next Page able The DP83840A is not Next Page capable so this bit is permanently set to 0.
14	ACK	0, RO/P	ACKNOWLEDGE: 1 = Reception of Link Partner ability data acknowledged 0 = Not acknowledged The DP83840A's Auto-Negotiation state machine will automatically control this bit in the outgoing FLP bursts, setting it at the appropriate time during the Auto-Negotiation process. Software should not attempt to write to this bit.
13	RF	0, RW	REMOTE FAULT: 1 = Advertises that this device has detected a Remote Fault 0 = No Remote Fault detected
12:10	Reserved	X, RW	RESERVED: Write as 0, read as don't care.
9	T4	0, RO/P	100BASE-T4 SUPPORT: 1 = 100BASE-T4 is supported by the local device 0 = 100BASE-T4 not supported The DP83840A does not support 100BASE-T4 so this bit is permanently set to 0.
8	TX_FD	1, RW	100BASE-TX FULL DUPLEX SUPPORT: 1 = 100BASE-TX Full Duplex is supported by the local device 0 = 100BASE-TX Full Duplex not supported
7	TX	1, RW	100BASE-TX SUPPORT: 1 = 100BASE-TX is supported by the local device 0 = 100BASE-TX not supported
6	10_FD	1, RW	10BASE-T FULL DUPLEX SUPPORT: 1 = 10BASE-T Full Duplex is supported by the local device 0 = 10BASE-T Full Duplex not supported
5	10	1, RW	10BASE-T SUPPORT: 1 = 10BASE-T is supported by the local device 0 = 10BASE-T not supported
4:0	Selector	<00001>, RW	PROTOCOL SELECTION BITS: These bits contain the binary encoded protocol selector supported by this node. <00001> indicates that this device supports IEEE 802.3 CSMA/CD

4.0 Registers (Continued)**4.7 AUTO-NEGOTIATION LINK PARTNER ABILITY REGISTER (ANLPAR)**

Address 05h

This register contains the advertised abilities of the Link Partner as received during Auto-Negotiation.

Bit	Bit Name	Default	Description
15	NP	0, RO	NEXT PAGE INDICATION: 0 = Link Partner not Next Page able 1 = Link Partner is Next Page able
14	ACK	0, RO	ACKNOWLEDGE: 1 = Link Partner acknowledges reception of the ability data word 0 = Not acknowledged The DP83840A's Auto-Negotiation state machine will automatically control the use of this bit from the incoming FLP bursts. Software should not attempt to write to this bit.
13	RF	0, RO	REMOTE FAULT: 1 = Remote Fault indicated by Link Partner 0 = No Remote Fault indicated by Link Partner
12:10	Reserved	X, RO	RESERVED: Write as 0, read as don't care.
9	T4	0, RO	100BASE-T4 SUPPORT: 1 = 100BASE-T4 is supported by the Link Partner 0 = 100BASE-T4 not supported by the Link Partner
8	TX_FD	0, RO	100BASE-TX FULL DUPLEX SUPPORT: 1 = 100BASE-TX Full Duplex is supported by the Link Partner 0 = 100BASE-TX Full Duplex not supported by the Link Partner
7	TX	0, RO	100BASE-TX SUPPORT: 1 = 100BASE-TX is supported by the Link Partner 0 = 100BASE-TX not supported by the Link Partner
6	10_FD	0, RO	10BASE-T FULL DUPLEX SUPPORT: 1 = 10BASE-T Full Duplex is supported by the Link Partner 0 = 10BASE-T Full Duplex not supported by the Link Partner
5	10	0, RO	10BASE-T SUPPORT: 1 = 10BASE-T is supported by the Link Partner 0 = 10BASE-T not supported by the Link Partner
4:0	Selector	<00000>, RO	PROTOCOL SELECTION BITS: Link Partner's binary encoded protocol selector.

4.0 Registers (Continued)**4.8 AUTO-NEGOTIATION EXPANSION REGISTER (ANER)**

Address 06h

Bit	Bit Name	Default	Description
15:5	Reserved	0, RO	RESERVED: Always 0.
4	MLF	0, RO/L	MULTIPLE LINK FAULT: 1 = Multiple Link Fault--indicates that it was not possible to resolve the connection because the 10BASE-T Link Integrity Test function and/or the 100BASE-X Link Integrity Monitor indicated a valid link yet both or neither of these functions maintained a valid link according to Auto-Negotiation specification. This bit generally indicates that the receive channel is improperly functioning or improperly connected. 0 = No Multiple Link Fault
3	LP_NP_ABLE	0, RO	LINK PARTNER NEXT PAGE ABLE: Status indicating if the Link Partner supports Next Page negotiation. A one indicates that the Link Partner supports Next Page.
2	NP_ABLE	0, RO/P	NEXT PAGE ABLE: Indicates if this node is able to send additional "Next Pages". The DP83840A is not Next Page Able, so this bit is always zero.
1	PAGE_RX	0, RO	LINK CODE WORD PAGE RECEIVED: This bit is set when a new Link Code Word Page has been received. This bit is automatically cleared when the Auto-Negotiation Link Partner Ability Register (ANLPAR register 05h) is read by management.
0	LP_AN_ABLE	0, RO	LINK PARTNER AUTO-NEGOTIATION ABLE: A one in this bit indicates that the Link Partner supports Auto-Negotiation.

4.9 DISCONNECT COUNTER REGISTER (DCR)

Address 12h

Bit	Bit Name	Default	Description
15:0	DCNT[15:0]	<0000h>, RW/SC	DISCONNECT COUNTER: This 16-bit counter increments for each disconnect event. Each time this DP83840A and its Link Partner are disconnected from each other, the counter increments. This counter automatically rolls over to 0000h.

4.10 FALSE CARRIER SENSE COUNTER REGISTER (FCSCR)

Address 13h

Bit	Bit Name	Default	Description
15:0	FCSCNT[15:0]	<0000h>, RW/SC	FALSE CARRIER EVENT COUNTER: This 16-bit counter increments for each false carrier event, that is, when carrier sense is asserted without J/K symbol detection. This counter freezes when full (at FFFFh). This counter represents the total number of false carrier events since the last management read. The Carrier Integrity Monitor uses its own counter to qualify whether the link is unstable.

4.0 Registers (Continued)**4.11 RECEIVE ERROR COUNTER REGISTER (RECR)**

Address 15h

Bit	Bit Name	Default	Description
15:0	RXERCNT[15:0]	<0000h>, RW/SC	RX_ER COUNTER: This 16-bit counter is incremented for each packet in which a receive error is detected. If there are one or more receiver error conditions during a valid packet reception (i.e. no collision occurred during packet reception), the counter is incremented once at the end of packet reception. This counter rolls over when full.

4.12 SILICON REVISION REGISTER (SRR)

Address 16h

Bit	Bit Name	Default	Description
15:0	SIREV[15:0]	<0001h>, RO/P	Silicon Revision Number: This register contains the DP83840A device's silicon revision code. The value will be incremented for each new major revision of the silicon.

4.13 PCS CONFIGURATION REGISTER (PCR)

Address 17h

Bit	Bit Name	Default	Description
15	NRZI_EN	1, RW	NRZI ENABLE: 1 = NRZI encoding and decoding of the 100Mb/s transmit and receive data streams 0 = NRZI encoding and decoding disabled
14	DESCR_TO_SEL	0, RW	DESCRAMBLER TIMEOUT SELECT: 1 = Descrambler Timer set to 2 ms 0 = Descrambler Timer set to 722 μ s The Descrambler Timer selects the interval over which a minimum number of IDLES are required to be received to maintain descrambler synchronization. The default time of 722 μ s supports 100BASE-X compliant applications. A timer timeout indicates a loss of descrambler synchronization which causes the descrambler to restart its operation by immediately looking for IDLES. The 2 ms option allows applications with Maximum Transmission Units (packet sizes) larger than IEEE 802.3 to maintain descrambler synchronization (i.e. Token Ring/Fast-Ethernet switch/router applications.)
13	DESCR_TO_DIS	0, RW	DESCRAMBLER TIMEOUT DISABLE: 1 = Timeout timer in the descrambler section of the receiver disabled 0 = Timeout timer enabled
12	REPEATER	(Pin #47), RW	REPEATER/NODE MODE: 1 = Repeater mode 0 = Node mode In repeater mode the Carrier Sense (CRS) output from the DP83840A is asserted due to receive activity only. In node mode, and not configured for Full Duplex operation, CRS is asserted due to either receive or transmit activity. The value of the REPEATER pin 47 (set by a pull-up or pull-down resistor, typically 4.7 k Ω) is latched into this bit at power-up/reset.

4.0 Registers (Continued)

4.13 PCS CONFIGURATION REGISTER (PCR) (Continued)

Address 17h

Bit	Bit Name	Default	Description
11	ENCSEL	0, RW	ENCODER MODE SELECT: 1 = External transceiver binary encoding 0 = External transceiver MLT3 encoding This bit drives the DP83840A's ENCSEL signal (pin 53). ENCSEL should be connected to the ENCSEL input of a DP83223 Twister.
10:8	Reserved	X, RO	RESERVED: Write as 0, read as don't care.
7	CLK25MDIS	0, RW	CLK25M DISABLE: 1 = CLK25M output clock signal (pin 81) tri-stated 0 = CLK25M enable This helps reduce ground bounce and power consumption should this output not be required. For applications requiring the CLK25M output, leave this bit set to 0. See Section 3.5 for more details.
6	F_LINK_100	1, RW	FORCE GOOD LINK IN 100 Mb/s: 1 = Normal 100 Mb/s operation 0 = Force 100 Mb/s Good Link status This forces good link and will assert the LINK LED. This bit is useful for diagnostic purposes.
5	CIM_DIS	(pin #47), RW	CARRIER INTEGRITY MONITOR DISABLE: 1 = Carrier Integrity Monitor function disabled (Node/Switch operation) 0 = Carrier Integrity Monitor function enabled (Repeater operation) The REPEATER pin (pin # 47) determines the default state of this bit to automatically enable or disable the CIM function as required for IEEE 802.3 compliant applications. After power-on/hardware reset, software may enable or disable this function independent of repeater or node/switch mode.
4	TX_OFF	0, RW	FORCE TRANSMIT OFF: 1 = 100 Mb/s outputs TD+/- inactive regardless of signalling on the MII interface. 0 = 100 Mb/s transmission outputs TD +/- enabled This will inhibit normal 100 Mb/s network activity and is provided only for test flexibility.
3	Reserved	X, RO	RESERVED: Write as 0, read as don't care.
2	$\overline{\text{LED1_MODE}}$	0, RW	LED1 MODE SELECT: 1 = $\overline{\text{LED1}}$ output (pin 42) configured to indicate connection status (CON_STATUS, bit 5 of the PAR, address 19h). This is useful for network management purposes in 100BASE-TX mode. 0 = Normal $\overline{\text{LED1}}$ operation--10 Mb/s and 100 Mb/s transmission activity
1	$\overline{\text{LED4_MODE}}$	0, RW	LED4 MODE SELECT: 1 = $\overline{\text{LED4}}$ output (pin 37) configured to indicate Full Duplex mode status for 10 Mb/s and 100 Mb/s operation 0 = $\overline{\text{LED4}}$ output configured to indicate Polarity in 10BASE-T mode or Full Duplex in 100BASE-TX mode
0	Reserved	X, RO	RESERVED: Write as 0, read as don't care.

4.0 Registers (Continued)

4.14 LOOPBACK, BYPASS AND RECEIVER ERROR MASK REGISTER (LBREMR)

Address 18h

Bit	Bit Name	Default	Description															
15	BAD_SSD_EN	1, RW	<p>BAD SSD Enable:</p> <p>1 = Enable Bad SSD detection 0 = Disable Bad SSD detection</p> <p>If Bad SSD is detected, then the DP83840A will assert RX_ER and present RXD[3:0] = 1110 to the MII for the cycles that correspond to received 5B symbols until at least two IDLE code groups are detected.</p> <p>Once at least two IDLE code groups are detected, RX_ER and CRS become de-asserted.</p> <p>RX_ER becomes RXD[4] in transparent mode such that RXD[4:0]=11110 during a Bad SSD event.</p> <p>When bit 12 of the LBREMR is one (Bypass Align mode), RXD[3:0] and RX_ER/RXD[4] are not modified regardless of the state of this bit.</p>															
14	BP_4B5B	(Pin #100), RW	<p>BYPASS 4B5B ENCODING AND 5B4B DECODING: The value of the BP4B5B pin (100) is latched into this bit at power-up/reset.</p> <p>1 = 4B5B encoder and 5B4B decoder functions bypassed 0 = Normal 4B5B and 5B4B operation</p>															
13	BP_SCR	(Pin #1), RW	<p>BYPASS SCRAMBLER/DESCRAMBLER FUNCTION: The value of the BPSCR pin (1) is latched into this bit at power-up/reset.</p> <p>1 = Scrambler and descrambler functions bypassed 0 = Normal scrambler and descrambler operation</p>															
12	BP_ALIGN	(Pin #99), RW	<p>BYPASS SYMBOL ALIGNMENT FUNCTION: The value of the BPALIGN pin (99) is latched into this bit at power-up/reset.</p> <p>1 = Receive functions (descrambler, symbol alignment and symbol decoding functions) bypassed. Transmit functions (symbol encoder and scrambler) bypassed 0 = Normal operation</p>															
11	10BT_LPBK	0, RW	<p>10BASE-T ENCODER/DECODER LOOPBACK:</p> <p>1 = Data loopback in the 10BASE-T ENDEC enabled 0 = Normal Operation</p>															
10	Reserved	(Pin #49), RW	RESERVED: Write as 0, read as don't care.															
9:8	LB[1:0]	<00>, RW	<p>LOOPBACK CONTROL BITS 1:0: These bits control the 100 Mb/s loopback function as follows:</p> <table border="1"> <thead> <tr> <th>LB1</th> <th>LB0</th> <th>Mode</th> </tr> </thead> <tbody> <tr> <td>0</td> <td>0</td> <td>Normal Mode</td> </tr> <tr> <td>0</td> <td>1</td> <td>DP83223 Twister Loopback</td> </tr> <tr> <td>1</td> <td>0</td> <td>Remote Loopback--Received data is looped back to the transmit channel, TD +/- . Received data is presented to the MII. Data transmitted over the MII has no effect on TD +/- .</td> </tr> <tr> <td>1</td> <td>1</td> <td>Reserved</td> </tr> </tbody> </table> <p>Note that Twister Loopback, like the internal loopback described in the BMCR bit 14 (address 00h), will produce a "dead time" of 550µs before any valid data appears at the TD +/- or RXD[3:0] outputs. BMCR bit 14, if set, take precedence over LB1 and LB0.</p> <p>Refer to section 3.11 for further detail.</p>	LB1	LB0	Mode	0	0	Normal Mode	0	1	DP83223 Twister Loopback	1	0	Remote Loopback--Received data is looped back to the transmit channel, TD +/- . Received data is presented to the MII. Data transmitted over the MII has no effect on TD +/- .	1	1	Reserved
LB1	LB0	Mode																
0	0	Normal Mode																
0	1	DP83223 Twister Loopback																
1	0	Remote Loopback--Received data is looped back to the transmit channel, TD +/- . Received data is presented to the MII. Data transmitted over the MII has no effect on TD +/- .																
1	1	Reserved																
7	Reserved	0, RW	RESERVED: Write as 0, read as don't care.															

4.0 Registers (Continued)**4.14 LOOPBACK, BYPASS AND RECEIVER ERROR MASK REGISTER (LBREMR) (Continued)**

Address 18h

Bit	Bit Name	Default	Description
6	ALT_CRS	0, RW	<p>ALTERNATE CRS OPERATION: This bit modifies the behavior of the CRS signal when the DP83840A is configured to Full Duplex mode. The described functionality allows flexibility for a given MAC's MII interface while operating in Full Duplex mode.</p> <p>1 = During Full Duplex mode CRS is asserted due to transmission and is not asserted due to reception via RD+/- (in 100 Mb/s mode) or RXI+/- (in 10 Mb/s mode)</p> <p>0 = During Full Duplex mode, CRS is asserted only due to reception via RD+/- (in 100 Mb/s mode) or RXI+/- (in 10 Mb/s mode)</p>
5	LBK_XMT_DS	1, RW	<p>100 Mb/s TRANSMIT DISABLE IN LOOPBACK:</p> <p>1 = Disables 100 Mb/s transmit outputs TD+/- during Loopback</p> <p>0 = Enables 100 Mb/s transmit outputs TD+/- during Loopback</p> <p>For Twister Loopback, this bit must be zero for loopback to be successful. For Phaser loopback (bit 14, BMCR, address 00h), this bit will determine whether a loopback operation is transmitted onto the network.</p>
4	CODE_ERR	0, RW	<p>CODE ERRORS:</p> <p>1 = Forces code errors to be reported with the value 5h on RXD[3:0] and with RX_ER set to 1</p> <p>0 = Forces code errors to be reported with the value 6h on RXD[3:0] and with RX_ER set to 1</p>
3	PE_ERR	0, RW	<p>PREMATURE END ERRORS:</p> <p>1 = Forces premature end errors to be reported with the value 4h on RXD[3:0] and with RX_ER set to 1</p> <p>0 = Forces premature end errors to be reported with the value 6h on RXD[3:0] and with RX_ER set to 1</p> <p>Premature end errors are caused by the detection of two IDLE symbols in the receive data stream prior to the T/R symbol pair denoting end of stream delimiter.</p>
2	LINK_ERR	0, RW	<p>LINK ERRORS:</p> <p>1 = Forces link errors to be reported with the value 3h on RXD[3:0] and with RX_ER set to 1</p> <p>0 = Data is passed to RXD[3:0] unchanged and with RX_ER set to 0</p>
1	PKT_ERR	0, RW	<p>PACKET ERRORS:</p> <p>1 = Forces packet errors (722 μs timeout) to be reported with the value 2h on RXD[3:0] and with RX_ER set to 1</p> <p>0 = Data is passed to RXD[3:0] unchanged and with RX_ER set to 0</p>
0	Reserved	0, RW	RESERVED: Write as 0, read as don't care.

4.0 Registers (Continued)

4.15 PHY ADDRESS REGISTER (PAR)

Address 19h

Bit	Bit Name	Default	Description
15:12	Reserved	0, RO	RESERVED: Write as 0, read as don't care.
11	DIS_CRIS_JAB	(pin #47), RW	<p>DISABLE CARRIER SENSE DURING JABBER: This bit controls the state of CRS upon a descrambler time-out event which can occur during a long jabber event in 100 Mb/s mode.</p> <p>1 = CRS will deassert after descrambler time-out has occurred.</p> <p>0 = CRS will remain asserted after descrambler time-out has occurred and will only deassert upon resynchronization of the descrambler.</p> <p>The default setting for this bit is dependent on the state of the REPEATER pin (47) upon power-up/reset. If the REPEATER pin is set low upon power-up/reset, then this bit will default to a one. If the REPEATER pin is set high upon power-up/reset, then this bit will default to zero.</p>
10	AN_EN_STAT	(pin #95, 46), RO	<p>AUTO-NEGOTIATION MODE STATUS: This bit reflects whether Auto-Negotiation has been enabled or disabled via the AN0, AN1 pins or bit 12 of the Basic Mode Control Register (address 00h.)</p> <p>1 = Auto-Negotiation mode has been enabled</p> <p>0 = Auto-Negotiation mode has been disabled</p>
9	Reserved	0, RO	RESERVED: Write as 0, read as don't care.
8	FEFI_EN	0, RW	<p>FAR END FAULT INDICATION ENABLE:</p> <p>1 = Enable FEFI function</p> <p>0 = Disable FEFI function</p> <p>FEFI is an function by which 100BASE-FX network devices can advertise that the receive channel has been disrupted (See Section 3.4.11.)</p>
7	DUPLEX_STAT	(pin #95, 46), RO	<p>DUPLEX STATUS: This bit indicates the current operational Duplex mode selected via the AN0, AN1 pins, bit 8 of the Basic Mode Control Register (address 00h), or through the Auto-Negotiation process.</p> <p>1 = DP83840A has been configured to Full Duplex mode</p> <p>0 = DP83840A has been configured to Half Duplex mode</p> <p>This bit is valid if bit 10 of the PAR (address 19h) is zero (Auto-Negotiation disabled) or bit 10 of the PAR is one and bit 5 of the BMSR (address 01h) is 1 (Auto-Negotiation complete.)</p> <p>This bit will also be valid if bit 2 of the BMSR (address 01h) is one, indicating a valid link condition.</p>
6	SPEED_10	(pin #95, 46)RO	<p>SPEED INDICATION: This bit indicates the current operational speed of the DP83840A.</p> <p>1 =10 Mb/s operation</p> <p>0 =100 Mb/s operation</p> <p>This bit is valid if bit 10 of the PAR (address 19h) is zero (Auto-Negotiation disabled) or bit 10 of the PAR is one and bit 5 of the BMSR (address 01h) is 1 (Auto-Negotiation complete.)</p> <p>This bit will also be valid if bit 2 of the BMSR (address 01h) is one, indicating a valid link condition.</p>
5	CIM_STATUS	0, RO/L	<p>CARRIER INTEGRITY MONITOR STATUS: This bit indicates the status of the Carrier Integrity Monitor function. This status is optionally muxed out through the $\overline{\text{LED1}}$ pin when the $\overline{\text{LED1_MODE}}$ register bit (bit 2 of the PCR, address 17h) is asserted.</p> <p>1 = Unstable link condition detected</p> <p>0 = Unstable link condition not detected</p>

4.0 Registers (Continued)**4.15 PHY ADDRESS REGISTER (PAR)**

Address 19h

Bit	Bit Name	Default	Description
4:0	PHYADDR[4:0]	(PHYAD[4:0]), RW	<p>PHY ADDRESS BITS 4:0: The values of the PHYAD[4:0] pins are latched to this register at power-up/reset. See Section 2.8 for the description of these pins.</p> <p>The first PHY address bit transmitted or received over the serial MII is the MSB of the address (bit 4). A station management entity must know the address of each PHY it is connected to in order to gain access.</p> <p>A PHY address of <00000> will cause the Isolate bit of the BMCR (bit 10, register address 00h) to be set.</p>

4.0 Registers (Continued)**4.16 10BASE-T STATUS REGISTER (10BTSR)**

Address 1Bh

Bit	Bit Name	Default	Description
15:10	Reserved	0, RO	RESERVED: Write as 0, read as don't care.
9	10BT_SER	(Pin #98), RW	10BASE-T SERIAL MODE: The value on the 10BTSER pin (98) is latched into this bit at power-up/reset. 1 = 10BASE-T serial mode selected (see Sections 2.5 and 3.1.3.3 for more details) 0 = 10BASE-T nibble mode selected (see Section 3.1.3.2) Serial mode is not supported for 100 Mb/s operation.
8:0	Reserved	0, RO	RESERVED: Write as 0, read as don't care.

4.17 10BASE-T CONFIGURATION REGISTER (10BTCR)

Address 1Ch

Bit	Bit Name	Default	Description
15	Reserved	1, RW	RESERVED: Write as 1, read as don't care.
14:8	Reserved	X, RO	RESERVED: Write as 0, read as don't care.
7	Reserved	1, RW	RESERVED: Write as 1, read as don't care.
6	Reserved	X, RO	RESERVED: Write as 0, read as don't care.
5	LP_EN	1, RW	LINK PULSE ENABLE: 1 = Transmission of link pulses enabled 0 = Link pulses disabled, good link condition forced When configured for 100 Mb/s operation with Auto-Negotiation enabled, clearing this bit will force the DP83840A into 10 Mb/s operation with link pulses disabled. If the DP83840A has been configured for 100 Mb/s operation with Auto-Negotiation disabled, this bit will not affect operation.
4	HBE	1, RW	HEARTBEAT ENABLE: 1 = Heartbeat function enabled 0 = Heartbeat function disabled When the DP83840A is configured for Full Duplex operation, this bit will be ignored (the collision/heartbeat function has no meaning in Full Duplex mode). This bit has no meaning in 100 Mb/s mode.
3	UTP/STP	1, RW	UTP/STP MEDIA SELECT: Selects between the Unshielded Twisted Pair (UTP) transmit outputs (TXU+/-) and the Shielded Twisted Pair (STP) transmit outputs (TXS+/-). 1 = UTP selected 0 = STP selected Only one output pair (TXU+/- or TXS+/-) may be selected at one time. The pair that is not selected will tri-state.
2	LSS	0, RW	LOW SQUELCH SELECT: Selects between standard 10BASE-T receiver squelch threshold and a reduced squelch threshold that is useful for longer cable applications and/or STP operation. 1 = Low Squelch Threshold selected 0 = Normal 10BASE-T Squelch Threshold selected
1	Reserved	0, RO	RESERVED: Write as 0, read as don't care.

4.17 10BASE-T CONFIGURATION REGISTER (10BTCCR) (Continued)

Address 1Ch

Bit	Bit Name	Default	Description
0	JABEN	1, RW	JABBER ENABLE: Enables or disables the Jabber function when the DP83840A is in 10BASE-T Full Duplex or 10BASE-T Transceiver Loopback mode (10BT_LPBK bit 11 in the LBREMR, address 18h). 1 = Jabber function enabled 0 = Jabber function disabled This bit has no meaning in 100 Mb/s mode.

5.0 DP83840A Application

5.1 Typical Board Level Application

Figure 20 shows a typical implementation of a 10/100 Mb/s Ethernet node application. This is given only to indicate the major circuit elements of such a design. It is not intended to be a full circuit diagram. For detailed system level application information please contact your National Semiconductor sales representative.

5.2 PLANE PARTITIONING

The recommendations for power plane partitioning provided herein represent a more simplified approach when compared to earlier recommendations. By reducing the number of instances of plane partitioning within a given system design, empirical data has shown a resultant improvement (reduction) in radiated emissions testing. Additionally, by eliminating power plane partitioning within the system Vcc and system ground domains, specific impedance controlled signal routing can remain uninterrupted.

Figure 21 illustrates one possible example of plane partitioning and allocation assuming a typical four-layer board design. The minimum gap between any two planes on a single layer must be held to 125 mils.

By placing chassis ground on the top and bottom layers, additional EMI shielding is created around the 125 Mb/s signal traces that must be routed between the magnetics and the RJ45-8 media connector. The example in Figure 17 assumes the use of Micro-Strip impedance control techniques for trace routing.

5.3 POWER AND GROUND FILTERING

Sufficient filtering between the DP83840A power and ground pins placed as near to these pins as possible is recommended. Figure 22 suggests one option for device noise filtering including special consideration for the sensitive analog and PLL power pins. The actual connection from ANAVCC to the 4Ω resistor should be implemented as a 'fat etch' (20 to 30 mils wide) of minimum length. The same technique should be implemented for the connection from PLLVCC to its 10Ω resistor.

The example provided in Figure 22 has been designed to minimize the number of physical decoupling components while still maintaining good overall device decoupling.

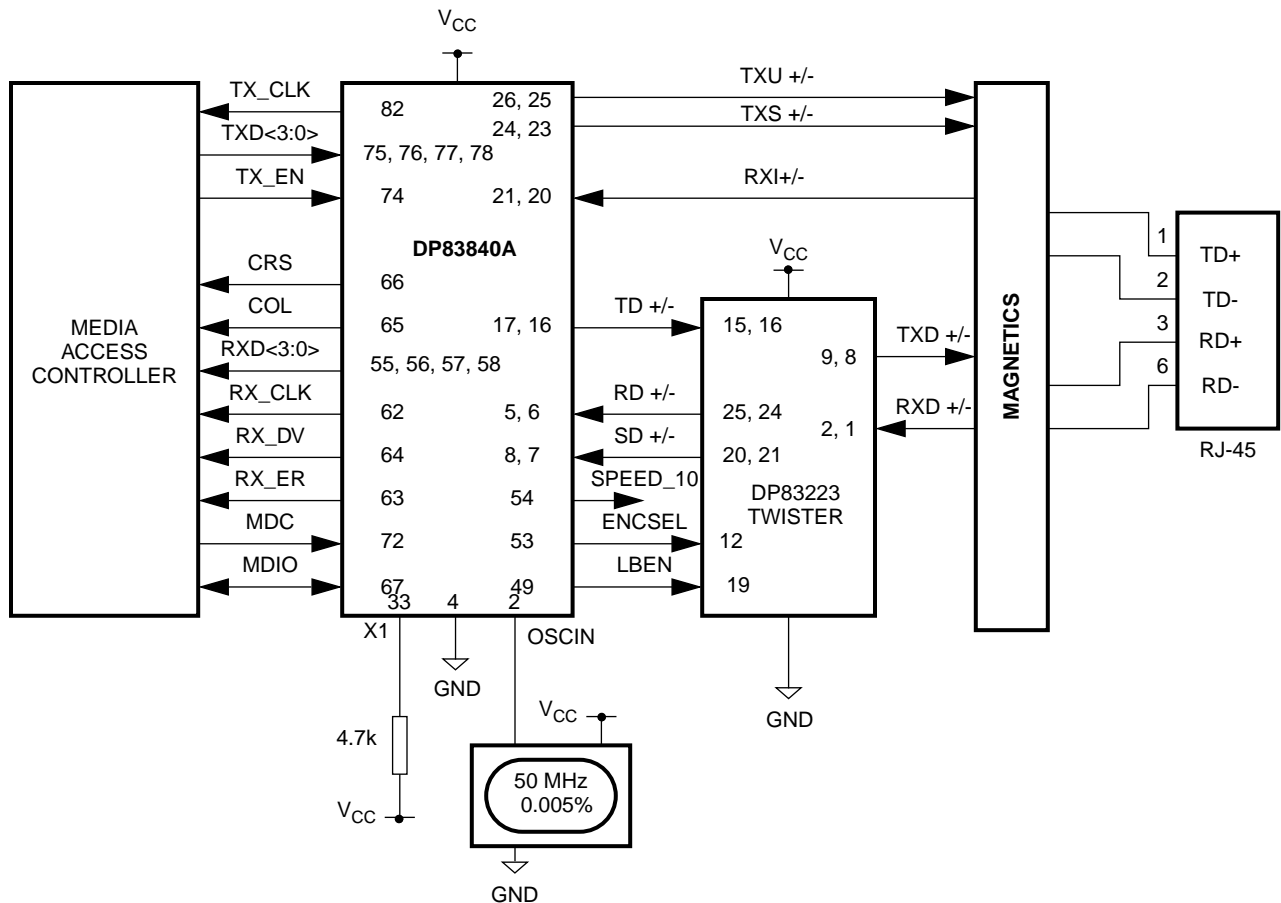

FIGURE 20. Typical 10/100 Ethernet Node Design Device Interconnection

5.0 DP83840A Application (continued)

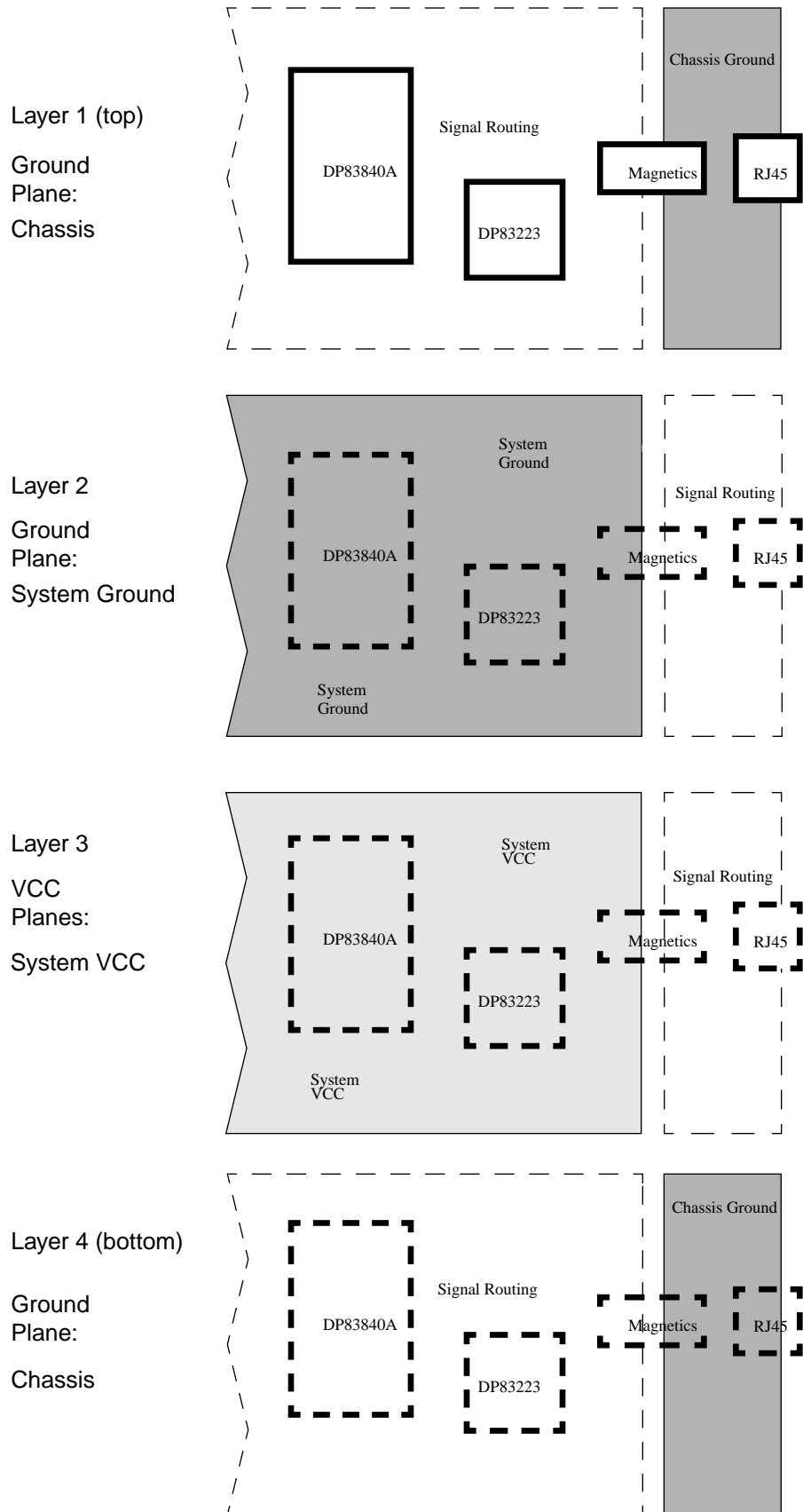
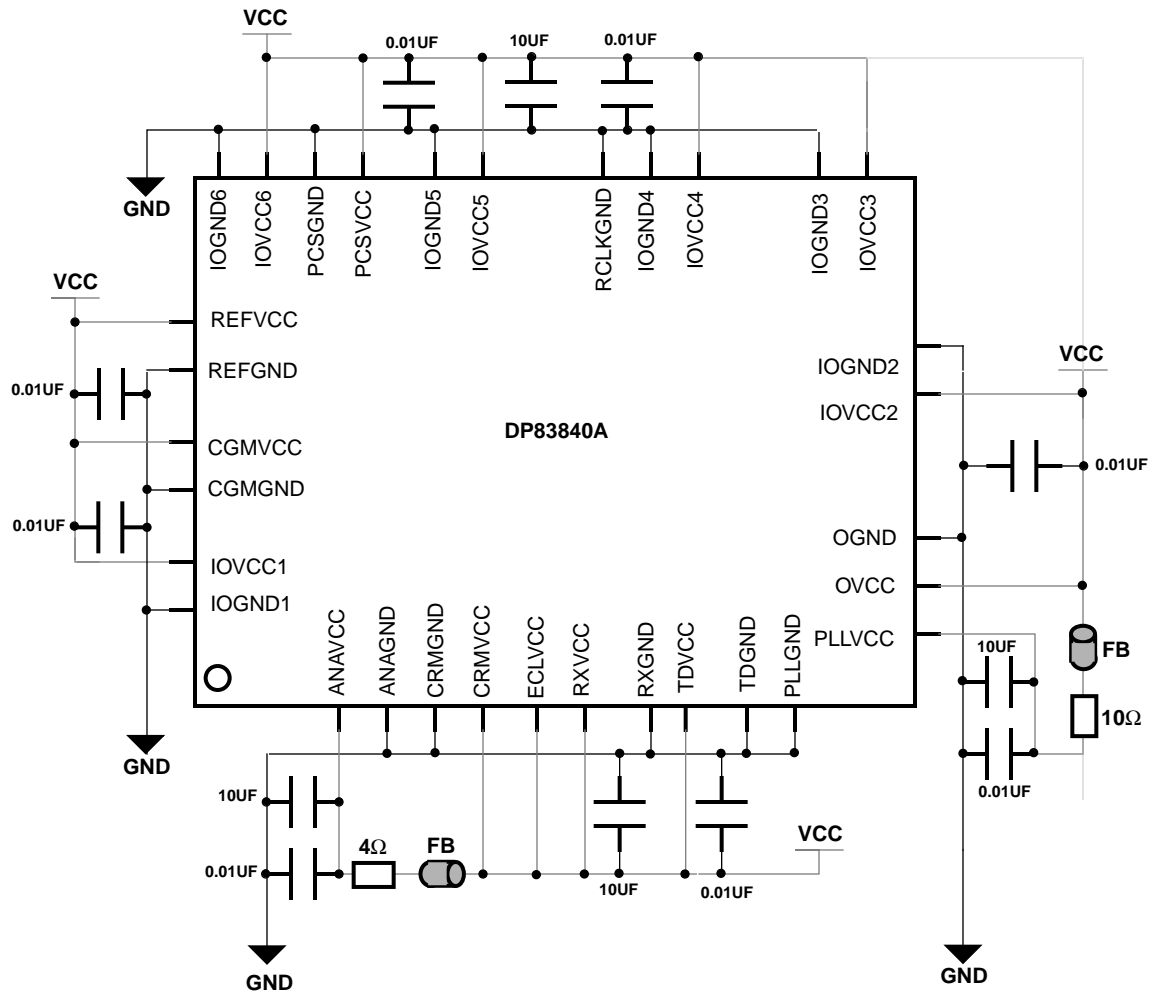

FIGURE 21. Power and Ground Plane Isolation

5.0 DP83840A Application (continued)



ALL CAPS ARE 16V CERAMIC

ALL RESISTORS ARE 1/8WATT, 5% TOLERANCE

FB  = FERRITE BEAD MURATA # BLM31A02PT
OR TDK # TDK-ACB1608M-080

FIGURE 22. DP83840A Power Supply Decoupling and Isolation

6.0 Hardware User Information

6.1 Jabber/Timeout

Problem:

During the CRS_Jabber fix implemented on the DP83840A, an unforeseen condition has resulted in undesirable behavior in the CRS signal. There exists a narrow region of improper CRS activity at the end of the 722 μ s timeout where the device recognizes the Jabber function.

Description:

If the data packet is essentially the same length as the default 722 μ s descrambler timeout CRS glitching will occur. More specifically if the data packet terminates within 600ns of the 722 μ s descrambler timeout, then the descrambler won't have sufficient time to recognize the necessary 15 idles before it times out. In that case the parallel CRS_JAB (internal signal) will assert CRS to indicate a jabber event.

Symptoms:

Since normal Ethernet packet activity is constrained to a maximum packet size of 1514 bytes, which is about 121 μ s, the CRS glitch will not show up with standard packet lengths. In the case that packets fall within the narrow range for CRS glitching, that packet will be lost. The next packet could be lost if the Inner-Packet-Gap (IPG) is too small relative to the CRS glitch, which varies from approximately 40ns to 600ns.

Solution/Workaround:

There is no current workaround to this problem. This problem will be corrected in the next silicon revision.

6.2 Link Timer

Problem:

Link Timer State Machine Counter will not reset to 0 if the Signal Detect falls while the Link Timer is in the HYSTERESIS state.

Description:

If the link state machine is in the HYSTERESIS state (Figure 24-15, clause 24.3.4.4 of 802.3u/D5.3), the timer counts down from 500 to 0. AT 0, link timer is done, the state machine transitions, and the timer is reset to 500. If Signal Detect falls while the link state machine is in the HYSTERESIS state, the state machine goes back to LINK_DOWN, but the timer does not reset, since the reset condition is based on the timer reaching 0. Thus when Signal Detect becomes asserted, the counter will resume counting where it left off, and not count the full 500 μ s.

Symptoms:

If the network is operating normally and receiving good data (Normal Link, substantial number of idles) no problems will be observed. If Signal Detect is varying (bad reception) the part would try to lock. If the lock was successful the DP83840A would report Bad Start of Stream Delimiter (Bad SSD) and the device would disconnect. In a Repeater application the DP83840A would see two Bad SSD's and disconnect that port. Only one packet would be lost and then the part would reconnect. In

a node application the Media Access Controller (MAC) would need to decipher if the data that was being received was bad.

Solution/Workaround:

There is no current workaround to this problem. This problem will be corrected in future products.

6.3 Link LED, Link Status Bit

Problem:

The Link LED which indicates good link status derives its signal from energy present on Signal Detect (SD+/-). The Link Status bit (bit 2) in the Basic Mode Control Register (00h) represents true link and derives its status from different conditions than the Link LED.

Description:

The Basic Status Register Link status operation is as follows:

This bit represents true link. In 100Base-TX it is Cipher in Sync. Cipher-in-sync is based on receiving 15 idle symbols after Link Test Fail (LTF) is low.

If link status is down it is updated in the bit, next clock cycle.

To get the link status, the user has to read the register twice. The last read will give the correct status, after the first read bit is updated with the new link status. This register bit operation is based on IEEE 802.3u (page 31, 802.3u/D5.3).

Symptoms:

It is possible for Link LED to have a different value than the Link Status Register bit.

Solution/Workaround:

For True Link, read the register status bit twice. The operation of the Link is IEEE 802.3 compliant.

6.4 PHYAD[3] and SPEED_100

Problem:

When using the SPEED_100 output (pin 89) of the DP83840A to control external circuitry such as certain switch elements for Common Magnetics implementations, care must be taken in order to avoid electrical contention between the effective load of the external circuitry and the power-on/reset latch-in value of the PHYAD[3] input (also pin 89).

Description:

The standard procedure for latching in the desired PHY Address of the DP83840A during power-on/reset is to resistively tie each of the five PHYAD pins either high or low such that one of the 32 possible addresses is programmed into the device. If the dual purpose PHYAD pin is connected to an external load which contends with the intended pull-up or pull-down resistor, the wrong logic level may be latched into the device which will result in an invalid (unintended) PHY address. This, in turn, will impair serial MII management of the PDP83840A.

6.0 Hardware User Information (Continued)

Symptoms:

An improper five bit PHY Address is latched into the DP83840A upon power-on/reset.

Solution/Workaround:

In order to guarantee that a **logic low** level is latched-in to PHYAD[3] upon power-up/reset, it is recommended that a 4.7kΩ resistor be connected from this pin directly to ground. Figure 23 illustrates the recommended connection of external circuitry when using PHYAD[3] / SPEED_100 to control transistors used for Common Magnetics implementations.

In order to guarantee that a **logic high** level is latched-in to PHYAD[3] upon power-up/reset, it is recommended that a 1.0kΩ resistor be connected from this pin directly to Vcc and that a 1.2kΩ resistor be connected in series between this pin and the transistor control circuitry. It is important to take note that the base resistor values (each 100Ω in this case) are lowered in order to compensate for the series

1.2kΩ resistor with respect to proper transistor biasing. Figure 24 illustrates the recommended connection of external circuitry when using PHYAD[3] / SPEED_100 to control transistors used for Common Magnetics implementations.

6.5 Collision De-Assertion Time

Problem:

In 100 Mb/s operation, the Collision De-Assertion time violates the IEEE802.3u specification.

Description:

The Collision De-Assertion time which is determined from when TX_EN is deasserted to COL going low is specified at 40ns maximum per IEEE 802.3u/D5.3 section 22.2.4.1.9. This is a test mode function. The DP83840A has a specification of 87ns maximum.

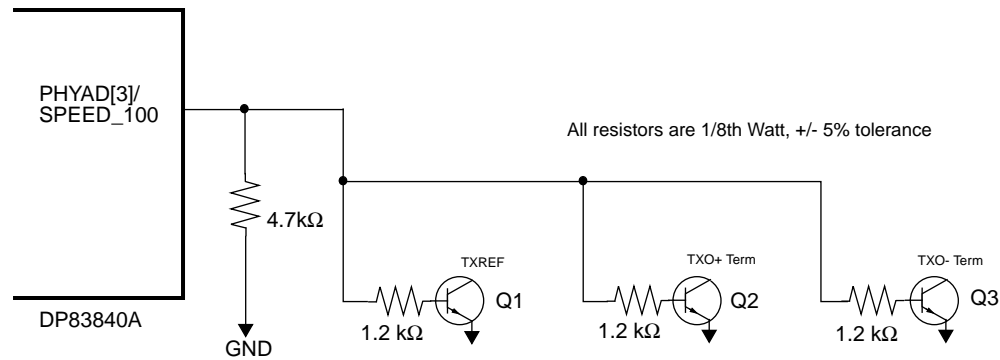

Figure 23. Recommended Control Circuitry and Valid PHYAD[3] Logic Low Latch-in Value

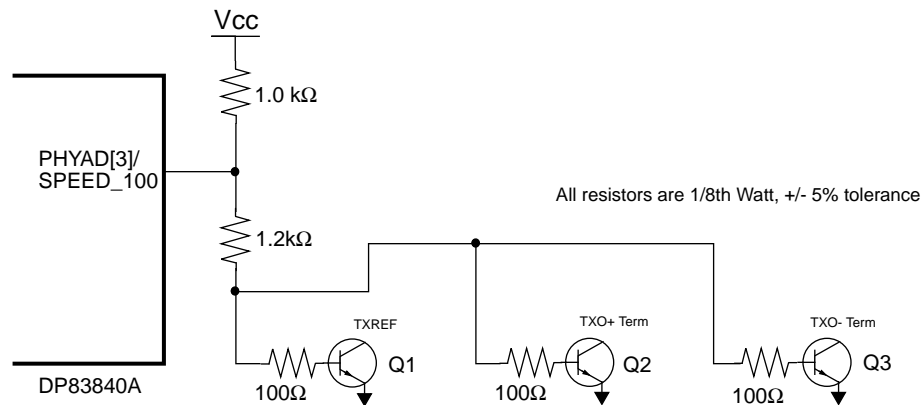

Figure 24. Recommended Control Circuitry and Valid PHYAD[3] Logic High Latch-in Value

6.0 Hardware User Information (Continued)

Symptoms:

The COL signal could go low up to 87ns after TX_EN goes low.

Solution/Workaround:

There is no current workaround to this test mode function. In a network environment, this will not be a problem.

6.6 Synchronization of Idle

Problem:

In 100 Mb/s operation, descrambler violates the TP-PMD specification of 12 idle times or 60 cipher bits.

Description:

The DP83840A will acquire descrambler synchronization in 13 symbols. However, due to latency and pipeline delays, the DP83840A can not provide valid decoded data less than 16 Idle symbols.

Symptoms:

If the Idle stream is between 13 and 16 symbols, the descrambler will synchronize to the transmit data, yet the Start of Frame Delimiter (SFD) will be lost resulting in the detection of a Bad_SSD. The subsequent packet following the next idle stream will be lost.

Solution/Workaround:

The minimum number of consecutive idles required for a proper network operation is sixteen. There is no current workaround to this problem. Since the minimum IPG in a network system is greater than 16 symbols, there is no real system impact for this problem.

6.7 10 Mb/s Differential Output Voltage

Problem:

Based on the characterization data across fab process, voltage, and temperature, the DP83840A is on the high side of the Vod specification.

Description:

The Vod measured without resistors connected to the RTX and REQ pins, ranges from 2.4V to 3.1V. IEEE 802.3

specifies the differential output voltage to be between 2.2V to 2.8V (zero to peak).

Symptoms:

National Semiconductor believes that there will be no system ramifications with higher than specified Vod voltages. The worse case scenario would be a slight increase in cross-talk in between the twisted pair cables.

Solution/Workaround:

If desired, the Vod voltage can be modified by connecting resistors from RTX (pin 28) and REQ (pin 29) to ground. Figure 25 illustrates the recommended connection of external circuitry which determines the Vod amplitude and shape. This will cause the Vod voltage to be lowered. Based on the data taken from the laboratory, National Semiconductor recommends starting with a 100kΩ resistors for both the RTX and REQ pins. The Vod will be in the range in between 2.2V to 2.9V when the 100kΩ resistors are used. The value of resistor you choose may be different based on your board layout and selection of components such as pulse transformers.

6.8 10Base-T Transmit Differential Output Impedance

Problem:

Based on the characterization data across fabrication process, voltage, and temperature, the DP83840A does not meet the letter of IEEE 802.3 10BaseT specification on the 10 Mb/s Transmit Differential Output Impedance (which is measured as return loss).

Description:

The IEEE 802.3 10BaseT standard requires a return loss of 15dB or better at all times (during transmit state or idle state) over the frequency range of 5 MHz to 10 MHz with a cable impedance range from 85Ω to 111Ω. The DP83840A characterization data shows that while the device meets the 15dB return loss specification during transmit and during idle on average, some devices may have return loss of less than 15dB during idle.

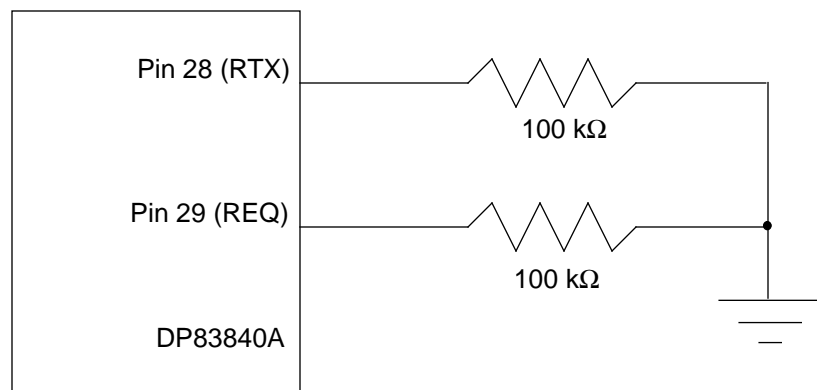

Figure 25. Recommended External Circuitry to Control the Amplitude and Shape of Vod

6.0 Hardware User Information (Continued)

Symptoms:

National believes that there will be no system ramification due to the DP83840A not meeting the IEEE specification for return loss. National Semiconductor has done extensive system testing with DP83840A's that have return loss in the range of 4-6dB, and did not see any degradation in system performance.

Solution/Workaround:

To improve the return loss at idle, National Semiconductor recommends that 1000pF capacitors be placed in parallel to the 10.5Ω termination resistors connected to the TXU+/- pins. Figure 26 illustrates the recommended connection of external components to improve return loss.

6.9 Low Power Mode

Problem:

The DP83840A sometimes fails to Auto-Negotiate when switching from 100 Mb/s link partner to a 10 Mb/s link partner when the low power pin (pin 2) is driven by Speed_100/PhyAdr<3> (pin 89).

The low power mode works when used in a 100 Mb/s only operation.

Description:

Any application using the DP83840A (with the low power pin driven by the Speed_100 pin) will sometimes fail to Auto-Negotiate to the 10 Mb/s link partner that has first established a link with a 100 Mb/s link partner and then is disconnected from the 100 Mb/s link partner and then connected to a 10 Mb/s link partner. The reason for this is that in 100 Mb/s mode, the part will be configured for low power mode and shut down the 10 Mb/s and Auto-Negotiation circuitry in the DP83840A and when it tries to connect to a 10 Mb/s link partner the 10 Mb/s and Auto-Negotiation circuitry might not be fully powered up.

Symptoms:

When this problem occurs, no link will be established with the 10 Mb/s link partner and the FLP signal being sent by

the DP83840A will be half its normal amplitude. This indicates that the 10 Mb/s section of the chip has not powered up properly.

Solution/Workaround:

It is recommended that in 10/100 application that the low power mode of the device not be used.

In 100 Mb/s only applications, it is recommended that the low power pin be pulled high through a 4.7kΩ resistor.

6.10 Software Reset

Problem:

Hardware Configuration pins require a (4.7kΩ or less) pull up/down resistor to insure that the Physical Address is stable at latching time.

Description:

The following is an explanation of events based on software reset:

1. First high byte is written via MDIO
2. Software reset is true for the next 500ns.
3. At synchronous de-assertion of the reset all mode pins and Phy Address pins are latched.
4. Output enables for Phy Address pins are disabled (they will become inputs) from start of the reset to 1700ns after reset assertion.
5. Within 250ns from assertion of software reset, the phy address has to be stable. This implies that the RC time constant should be faster than 250ns so that Phy address will be latched correctly with reset synchronous de-assertion.
6. DP83840A Phy Address pin drivers have been modified to provide more drive current than the DP83840. This will increase the capacitance at the pin, hence the resistance will need to be reduced accordingly to keep the time constant low.

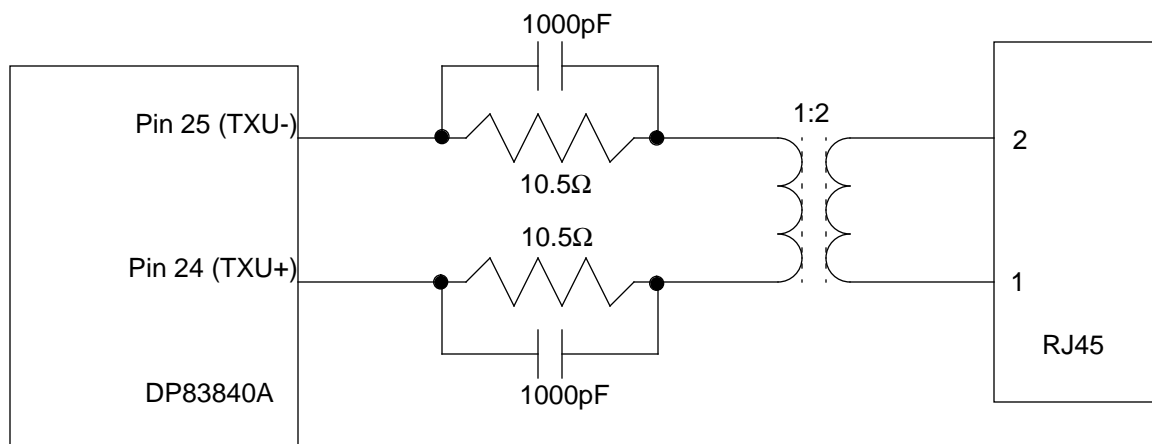

Figure 26. Recommended External Circuitry to Improve Transmit Return Loss

6.0 Hardware User Information (Continued)

7. Reduce the pull up/down resistance to 4.7kΩ to make the Phy Address stable at the latching time of 250ns. If the capacitance at the node is large due to a particular application, then the resistance will need to be lowered even further.

Symptoms:

If the time constant at the Phy Address pins is in excess of 250ns then the proper hardware configurations values may not be latched into the device after the software reset is initiated.

Solution/Workaround:

Use 4.7kΩ resistors or resistors with lower values on all PhyAddr pull up/down pins.

6.11 Receive Error Counter

Problem:

When receiving two back to back packets that have receive errors (symbol errors), the DP83840A under certain conditions records only the second symbol error (i.e. the Receive Error Counter only gets incremented once for both errors).

Description:

When a symbol error occurs at the very end of a packet, it doesn't get reflected in the Receive Error Counter (Bits 15:0, Address 15h) until the next packet is in progress (an internal synchronization issue between the receive clock domain and the register clock domain). Normally, this isn't a problem, the counter gets updated during the next packet. The problem occurs when the packet with the "late" symbol error backs up against another packet with a symbol error. In that case, the counter only gets incremented once for both errors. The end result is that the counter misses a count.

Symptoms:

The Receive Error Counter, bits 15:0 in the Receive Error Counter Register (15h), under certain conditions can record a value in the register that is less than the true receive error count.

Solution/Workaround:

There are no workarounds for this problem. This problem will be fixed in future products.

6.12 Auto-Negotiation Test Compliancy

Problem:

During Auto-Negotiation conformance testing, by an independent lab, four test conformance issues were uncovered. **We do not believe these four test conformance issues will cause any system issues.** The four issues are:

- 1.) The part improperly enters the Acknowledge Detect state upon receiving two groups of four inconsistent FLPs, i.e.(the data in the FLPs alternate)
- 2.) The value of the nlp_test_min_timer is between 3.8ms and 4.9ms, which is below the 5ms minimum requirement.
- 3.) The value of the data_detect_min_timer is valid except when a pulse is received before the timer has expired.
- 4) The value of link_fail_inhibit_timer is 640ms, which is below the 750ms minimum requirement.

Description:

Described below are the four conformance tests that the DP83840A failed. Currently IEEE does not have standard tests to test for conformance. The tests performed by the outside lab correspond to the four issues listed above.

Test 1: The DP83840A is sent two groups of four FLP bursts with a inter-group gap greater than nlp_test_max_timer of 150ms. An example of the FLP burst is shown below:

ABAB (Inter-group gap) ABAB

Where A represents a Link Code Word advertising a technology such as 10 Mb/s half-duplex and B represents a Link Code Word that is advertising a different technology such as 100 Mb/s full-duplex.

When this ABAB (Inter-group gap) ABAB pattern is received by the DP83840A, it will set the ACK bit.

Test 2: The DP83840A when sent four FLPs with a burst to burst gap less than the 5ms speck. will set the ACK bit.

Test 3: The DP83840A when sent four FLPs with a 'erroneous' extra pulse after one of the clock pulses does not ignore the extra pulse and as a result, the ACK bit is not set.

Test 4: The DP83840A is sent a sequence of FLPs to cause it to enter the FLP Link Good Check state. Upon entering this state, the DP83840A should cease FLP transmission and see all link_status indications as FAIL. After link_timer and break_link_timer expires, the DP83840A should resume FLP transmission. The DP83840A failed the Link_fail_inhibit_timer test with a value of 640ms which is below the 750ms limit.

Symptoms:

It is our opinion that the four issues found by the outside lab will not affect system performance. Listed below are the reasons we believe there will not be any system issues.

Issue 1: In a real network, the Auto-Negotiation protocol is such that, once enabled, the FLP bursts should be sent constantly, not in groups of 2, 4, 8, etc., with a number of seconds in between FLP bursts (No inter-group gap). The outside lab pointed out that the DP83840A implementation works fine when the FLP bursts are constant, even if the data within the bursts change.

Issue 2: The function of the NLP test timer is to ensure that the FLP bursts are not spaced too close together and to ensure that the data pulse to clock pulse timing is not too long. The transmit specification for FLP burst spacing is 8ms min. Most, if not all applications center the FLP burst spacing around 16ms. The data pulse to clock pulse timing should be approximately 78μs maximum. As long as the transmitter that is sending FLPs to the DP83840A is within specifications, then having the NLP timer expire 1.2ms early will not have any affect on Auto-Negotiation.

Issue 3: The extra 'erroneous' pulse is used to simulate noise injected into the FLP stream which can potentially corrupt the FLP burst. The Auto-Negotiation transmit protocol requires the transmitter to send the same FLP burst repeatedly (not just four times). Thus, if the DP83840A receives an extra 'erroneous' pulse, then it will take a few additional FLP bursts to set the ACK bit.

Issue 4: The link_fail_inhibit_timer is used to give the link a chance to become good once a technology is selected. The DP83840A will establish good link within

6.0 Hardware User Information (Continued)

approximately 250ms max., as long as it is getting valid signals. Since the link_fail_inhibit_timer only needs to be larger than the worst case link up time for all technologies supported (10BASE-T and 100BASE-TX link up times are much smaller than 640ms), then 640ms vs.750ms will not cause any system problems.

Solution/Workaround:

There are no plans on fixing any of the issues on the DP83840A. We will incorporate changes to fix the above issues in future products to insure our products a specification compliant.

7.0 Software User Information

7.1 100 Mb/s Full Duplex Log-On

Problem:

Certain Software drivers that were developed for the DP83840 do not account for the longer auto-negotiation time that is required for the DP83840A to complete Auto-Negotiation. This is discussed in the IEEE specification 802.3U from draft D2 to D5. The Auto-Negotiate time has increased from 1 second to approximately 3 seconds between the two devices.

Description:

The problem can be seen when the server or the client physical layer device is the DP83840A. When the client is attempting to log on to the server the user will see CRC errors occurring until the client times out and disconnects. The driver software that was written for the DP83840 needs to be modified to account for the additional time per the specification 802.3(D5.3) that is required for the DP83840A to complete Auto-Negotiation.

Symptoms:

A Novell server and a Novell DOS client that are connected via a crossover cable will not log on to 100 Mb/s Full Duplex with the DP83840A in the client or the server.

Solution/Workaround:

The solution is to modify the driver software to accommodate the longer Auto-Negotiation time that is required. The basic script should be the following:

- A.) Wait for auto-negotiation to complete (Three seconds)
- B.) Verify whether the auto-negotiation is completed by reading BSMR bit<5>.
- C.) If BMSR<5> is set read the BMSR to update the link status BMSR<2>.
- D.) If the BMSR<2> is set, read the PAR (19h) register. PAR bits<7:6> reflect the Duplex_STAT and Speed_10 status.

7.2 Auto-Negotiation to Link Sending 100 Mb/s Scrambled Idles.

Problem:

The DP83840A when Auto-Negotiating with a 100 Mb/s link partner that is sending out 100 Mb/s scrambled idles can, for specific cable lengths, approximately 35 to 41 meters or equivalent attenuation, misinterpret the 100 Mb/s scrambled idles as FLP's (Fast Link Pulses), thereby causing a false MLF (Multiple Link Fault) condition which hangs the Auto-Negotiation process (No link established).

This problem only occurs with the above scenario and does not affect other methods of linking such as Auto-Negotiating to a 10 Mb/s link partner, Auto-Negotiating to a Auto-Negotiation link partner, forcing the DP83840A into 100 Mb/s mode and linking to a 100 Mb/s link partner, and forcing the DP83840A into 10 Mb/s mode and linking to a 10 Mb/s link partner.

Description:

When Scrambled 100 Mb/s idles are transmitted, the energy is dispersed across the spectrum from 1MHz to

31.25 MHz. Some of this energy is aliased in the 10 Mb/s domain and for specific cable lengths, between 35meters to 41meters or equivalent attenuation, is falsely detected as FLP pulses. At these specific cable lengths, the Auto-Negotiation receive state machine will misconstrue enough FLP pulses such that it fits the FLP template, thereby notifying the arbitration state machine of the receipt of FLP pulses.

At the same time the misconstrued FLP's are being detected, the arbitration state machine is moving through the parallel detection path. This causes the arbitration state machine to think that it is receiving both FLP pulses and 100 Mb/s scrambled idles, thereby, causing a parallel detection fault (MLF bit 4 set high in the Auto-Negotiation expansion register (06h)), and hanging the Auto-Negotiation process.

Symptoms:

This problem only occurs when a system using the DP83840A is in Auto-Negotiation mode and tries to establish link with a system that is sending out 100 Mb/s scrambled idles and the cable length is approximately 35meters to 41 meters or equivalent attenuation. When the problem occurs the following will be observed:

- A.) Pin 38 (Link LED) will go low indicating 100 Mb/s activity.
- B.) The Multiple Link Fault bit (bit 4) of the Auto-Negotiation Expansion Register (06h) is HIGH, indicating the DP83840A thinks FLP's were being received.
- C.) The Link Status bit (bit 2) of the Basic Mode Status Register (01h) is LOW, indicating link not established.
- D.) The Auto-Negotiation Complete bit (bit 3) in the Basic Mode Status Register (01h) is LOW, indicating Auto-Negotiation not complete.

Solution/Workaround:

For existing products using the DP83840A the following can be done to work around the problem:

- A.) Manually configure the system using the DP83840A into 100 Mb/s mode through software. Many installation programs already support this capability.
- B.) Modify software driver to detect fault condition. A proposed software driver work around for this problem follows:

The workaround is based upon the concept that a DP83840A that is failing to complete negotiation is attempting to negotiate with a non-Auto-Negotiation-capable 100 Mb/s link partner. In that case, the software driver can force the local node/port directly into 100 Mb/s Half-Duplex mode to complete negotiation. Half-Duplex 100 Mb/s mode is what the Auto-Negotiation logic would select had the fault not occurred. The total time that Auto-Negotiation will take to complete is under 3 seconds. Therefore, the proposed software driver should implement the following:

Reset the 840A the DP83840A by writing 8000h to BMCR register, or re-start Auto-Negotiation by writing 1200h to BMCR register. Wait 3 seconds then read bit 5 (Auto-Negotiation Complete bit) and bit 2 (Link_Status bit) in the

7.0 Hardware User Information (Continued)

Basic Mode Status Register (01h). The Link Status bit must be read twice, since it's a latched bit. If bit 2 and bit 5 are set to a logic 1, then Auto-Negotiation completed successfully. Bits 6 and 7 in the Phy Address Register (19h) contain the information on Speed and Duplex (FD/HD).

If the Link_Status bit OR the Auto-Negotiation Complete bit are still logic 0 (bits 2 and 5) in the Basic Mode Status Register (01h), then negotiation did not complete. Read bit 4 (Multiple Link Fault) in the Auto-Negotiation Expansion Register (06h). ANER bit 4 must be read twice, since it's a latched bit. If the Multiple Link Fault bit is set to a logic 1, then the device can be forced into 100 Mb/s Half-Duplex operation via register control.

On the Basic Mode Control Register (00h) set bit 12 (Auto-Negotiation Enable) to a logic 0, set bit 13 (Speed Selection) to a logic 1 for 100 Mb/s operation, and bit 8 to logic 0 for Half-Duplex operation. (i.e. write 2000h to the Basic Mode Control Register). This disables Auto-Negotiation and puts the part into 100 Mb/s mode.

Check Link Status (bit 2 of Basic Mode Status Register) bit by reading BMSR register twice. If bit 2 is set to "1", then the local node/port is linked to the non Auto-Negotiation 100 Mb/s partner.

If bit 2 of the BMSR is not set, then force the device into 10 Mb/s mode by writing 0000h to BMCR register (00h).

Check Link Status (bit 2 of Basic Mode Status Register) bit by reading BMSR register twice. If bit 2 is set to "1", then the local node/port is linked to the non Auto-Negotiation 10 Mb/s partner.

National is evaluating a silicon fix to correct this problem. Please contact your Sales Representative for the current status.

7.3 840A Auto-Negotiating to Legacy Devices

Problem:

The DP83840A will not always complete Auto-Negotiation when Auto-Negotiating with a 100 Mb/s or 10 Mb/s link partner that is sending out packet data before link has been established.

Description:

The DP83840A in Auto-Negotiation mode is not always able to establish link with a 100 Mb/s link partner that is sending out scrambled packet data. The reason for this is that the DP83840A is expecting to see only 100 Mb/s idles, Fast Link Pulses (FLPs), or Normal Link Pulses (NLPs) and not scrambled packet data. When the DP83840A sees scrambled packet data, it can be misconstrued as NLPs and FLPs, which confuses the Auto-Negotiation state machine.

The DP83840A in Auto-negotiation mode may not be able to complete Auto-Negotiation with a 10 Mb/s link partner that is sending out packets prior to getting a good link. The reason for this is that the DP83840A can mis-identify some specific 10 Mb/s packet energy as 100 Mb/s data. When the DP83840A receives those specific 10 Mb/s packets, it will get confused on which speed to detect.

The 802.3U IEEE specification does not allow transmission of data prior to getting Good Link Status. The DP83840A is compliant to this specification, but some Legacy devices

are not, such as the DP83840, which will transmit data before Good Link Status is achieved. The problem with the 10 Mb/s is very limited. It only happens when Auto-Negotiation is initiated by software (i.e. writing 1200h to BMCR), and does not happen with un-plugging and re-plugging of cable, or H/W or S/W reset. Since there are very few 10 Mb/s only DP83840 Legacy devices out in the market, the possibilities of not being able to Auto-Negotiate with a 10 Mb/s device is very minimal.

Symptoms:

When the DP83840A receives packet data during Auto-Negotiation, the Auto-Negotiation state machine thinks that there are multiple links present and sets the Multiple Link Fault Bit (bit 4) in the AUTO-NEGOTIATION EXPANSION REGISTER (06h). The problem can be seen with 64 byte 100 Mb/s packets with Inter-Packet-Gaps (IPG) of less than 5 μ s, or 64-128 byte 10 Mb/s packets with IPG of 9.6 μ s.

Solution/Workaround:

The same workaround described in 011.E (Auto-Negotiating to Link Partner Sending 100 Mb/s Scrambled Idles) will also work with this problem:

A.) Manually configure the system using the DP83840A into 100 Mb/s or 10 Mb/s mode through software. Many installation programs already support this capability.

B.) Modify software driver to detect fault condition.

7.4 HBE Disable in 10 Mb/s Repeater Mode

Problem:

According to the 802.3 IEEE specification Heart Beat Enable (HBE) must be disabled when used in repeaters. The DP83840A when put into 10 Mb/s repeater mode does not disable HBE automatically and must be set manually.

Description:

Approximately 1.6 μ s after the end of a packet the COL line will become active for approximately 1.3 μ s. A repeater using the COL line to determine collisions or gather collision statistics will misinterpret the HBE signal as a valid collision.

Symptoms:

With HBE enabled in repeater mode the COL line will become active after the end of packet and cause the repeater to falsely detect collision activity.

Solution/Workaround:

HBE can be disabled by writing a 0 to bit 4 (HBE) in the 10BASE-T CONFIGURATION REGISTER (1Ch).

HBE can also be disabled by putting the part into Full-Duplex mode.

7.5 CRS Glitching in 10 Mb/s Repeater Mode

Problem:

When the DP83840A is put into 10 Mb/s repeater mode and receives a non-101010... jam pattern, Carrier Sense (CRS) will glitch during collision. This will cause problems when used in repeater applications where CRS is used to determine collisions. The collision signals from the DP83840A behave normally.

7.0 Hardware User Information (Continued)

Description:

The DP83840A when in 10 Mb/s Repeater Mode does not conform to 802.3 IEEE specification for Carrier Sense (CRS). The specification states that CRS becomes active whenever the receive input becomes active and in-active when there is no activity. The DP83840A uses its' internal Phase Lock Loop (PLL) to gate CRS. This causes CRS to glitch when the PLL switches from Receive mode to Transmit mode and when the PLL switches from Transmit to Receive mode. The switching of modes is what occurs during collisions.

Symptoms:

When the part is receiving a packet and then TX_EN is asserted, CRS will glitch twice, once following the rising edge of TX_EN and once following the end of RXI+/. This is illustrated in Figure 27.

When the part receives a JAM signal that has a combination of 5 MHz and 10 MHz signals, CRS will glitch. CRS behaves normally when a 101010... JAM pattern is received. All repeaters and most MACs send out 101010... JAM signals, but there are a few MACs that will send out pseudo-random 5/10 MHz data.

Solution/Workaround:

Putting the part into Full-Duplex mode eliminates the CRS glitching problem. However, when the part is in Full-Duplex mode the COL pin (pin 65) will not indicate if collisions have occurred.

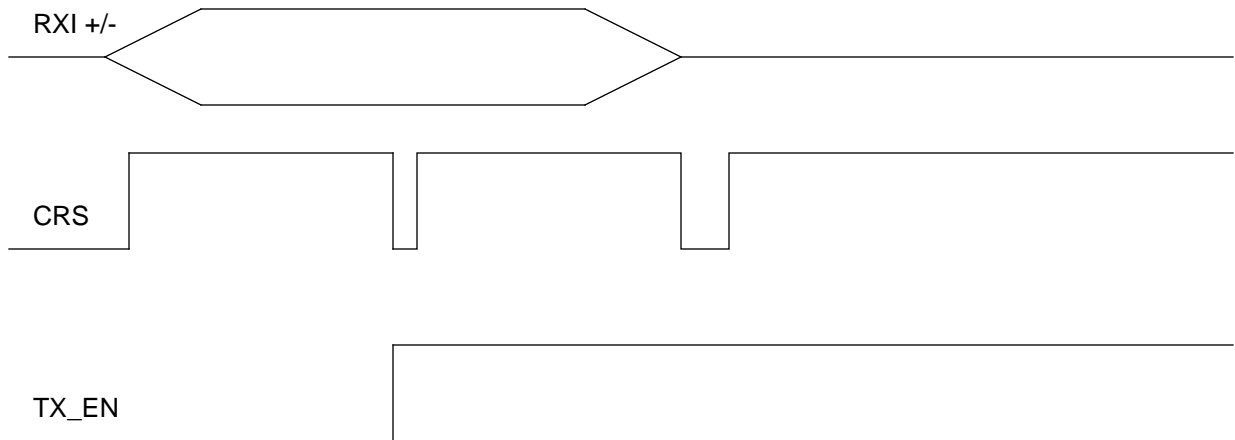

FIGURE 27. CRS Glitching

8.0 Electrical Specifications

8.1 RATINGS AND OPERATING CONDITIONS

8.1.1 Absolute Maximum Ratings

Supply Voltage (V_{CC})	-0.5 V to 7.0 V
Input Voltage (DC_{IN})	-0.5 V to $V_{CC} + 0.5$ V
Output Voltage (DC_{OUT})	-0.5 V to $V_{CC} + 0.5$ V
Storage Temperature	-65°C to 150°C
ECL Signal Output Current	-50mA
ESD Protection	2000 V

8.1.2 Recommended Operating Conditions

	Min	Typ	Max	Units
Supply voltage (V_{dd})	4.75	5.0	5.25	V
Ambient Temperature (T_A)	0		70	°C
REFIN Input Frequency (25 MHz)	-50		+50	ppm
REFIN Input Duty Cycle	35		65	%
OSCIN Input Frequency (50 MHz)	-50		+50	ppm
OSCIN Input Duty Cycle	35		65	%
Crystal Specifications:				
Crystal Center Frequency (X_{FC})		20		MHz
Crystal Freq. Stability (X_{STAB}) (Over Temperature)	-50		+50	ppm

8.1.3 Thermal Characteristics

	No Airflow 0.5W / 1.0W / 2.0W	225 LFPM 1.0W	500 LFPM 1.0W	900 LFPM 1.0W	Theta Junction to Case (T_{jc}) @ 1.0W
Theta Junction to Ambient (T_{ja}) degrees Celsius/Watt	36.3 / 35.9 / 34.3	28.7	24.3	21.9	10.5

MAXIMUM JUNCTION	130 degrees Celsius
MAXIMUM CASE	110 degrees Celsius

8.2 DC Specifications

Symbol	Pin Types	Parameter	Conditions	Min	Typ	Max	Units
V_{IH}	I I/O I/O, Z (excluding RXI+/- and RD+/-)	Input High Voltage		2.0			V
	AN0 and AN1 Input Pins		$I_{IH} = 2$ mA	$V_{CC} - 1.0$			V
V_{IL}	I I/O I/O, Z (excluding RXI+/- and RD+/-)	Input Low Voltage				0.8	V
	AN0 and AN1 Input Pins		$I_{IL} = -2$ mA			1.0	V
V_{IM}	AN0 and AN1 Inputs Only	Input Mid Level Voltage	Pin Unconnected	$(V_{CC}/2) - 0.25$	$(V_{CC}/2)$	$(V_{CC}/2) + 0.25$	V
I_{IH}	I I/O I/O, Z (excluding RXI+/- and RD+/-)	Input High Current	$V_{IN} = V_{CC}$			10	μ A
	X1 Input		X2 = N.C.			-100	μ A

8.0 Electrical Specifications (Continued)

8.2 DC Specifications

Symbol	Pin Types	Parameter	Conditions	Min	Typ	Max	Units
I_{IL}	I I/O I/O, Z (excluding RXI+/- and RD+/-)	Input Low Current	$V_{IN} = GND$			10	μA
	X1 Input		X2 = N.C.			100	μA
	TMS, TDI, \overline{TRST} Inputs					1	mA
V_{OL}	O, Z I/O I/O, Z	Output Low Voltage	$I_{OL} = 4 \text{ mA}$			0.4	V
V_{OH}	O, Z I/O I/O, Z	Output High Voltage	$I_{OL} = -4 \text{ mA}$	$V_{CC} - 0.5$			V
	TX_CLK Pin			$V_{CC} - 1.5$			V
I_{OZ1}	I/O, Z O, Z	TRI-STATE Leakage	$V_{OUT} = V_{CC}$			10	μA
I_{OZ2}	I/O, Z O, Z	TRI-STATE Leakage	$V_{OUT} = GND$			-10	μA
R_{OL}	TXU+/- TXS+/-	Low Level Output Impedance			5		Ω
R_{OH}	TXU+/- TXS+/-	High Level Output Impedance			5		Ω
V_{OD}	TXU+/- TXS+/-	Differential Output Voltage	Open Circuit		+/-2.5		V
C_{IN1}	I	CMOS Input Capacitance			8		pF
C_{IN2}	I	ECL Input Capacitance			5		pF
C_{OUT1}	O Z	CMOS Output Capacitance			10		pF
C_{OUT2}	O Z	ECL Output Capacitance			5		pF
V_{TH1}	RXI+/-	10BASE-T Receive Threshold		300		585	mV
V_{TH2}	RXI+/-	10BASE-T Receive Low Squelch Threshold		175		300	mV
V_{DIFF}	I (ECL)	Input Voltage Differential	Both inputs tested together	150			mV
V_{CM}	I (ECL)	Common Mode Voltage	Both Inputs Tested Together, $V_{DIFF} = 300$ mV	$V_{CC} - 2.0$		$V_{CC} - 0.5$	mV

8.0 Electrical Specifications

8.2 DC Specifications

Symbol	Pin Types	Parameter	Conditions	Min	Typ	Max	Units
I_{INECL}	I (ECL)	Input Current	$V_{IN} = V_{CC}$ or GND	-200		200	μA
V_{OHECL}	O (ECL)	Output High Voltage	$V_{IN} = V_{IHmax}$	$V_{CC} - 1.075$		$V_{CC} - 0.830$	V
V_{OLECL}	O (ECL)	Output Low Voltage	$V_{IN} = V_{ILmax}$	$V_{CC} - 1.860$		$V_{CC} - 1.570$	V
I_{CC}	power	Total Supply Current	10/100 Mb/s Operation (LOWPWR = 0)		315	335	mA
	power	Total Supply Current	100 Mb/s Operation (LOWPWR = 1)		270	290	mA

8.0 Electrical Specifications

8.3 CLOCK TIMING

8.3.1 Clock Reference and Clock Generation Timing

Parameter	Description	Notes	Min	Typ	Max	Units
T1	OSCIN to CLK25M Delay	OSCIN = 50 MHz	0	30	40	ns
T2	CLK25M Rise Time	10% to 90%		5		ns
T3	CLK25M Fall Time	90% to 10%		5		ns
T4	OSCIN to TX_CLK Delay	10 Mb/s Operation (MII Nibble Mode)		10		ns
T4a	OSCIN to TX_CLK Delay	10 Mb/s Operation (MII Serial Mode)		10		ns
T5	REFIN to TX_CLK Delay	100 Mb/s Operation	-3.0		+3.0	ns
T6	TX_CLK Duty Cycle	10 Mb/s Nibble (2.5 MHz), 10 Mb/s Serial (10 MHz) 100 Mb/s Nibble (25 MHz)	35		65	%

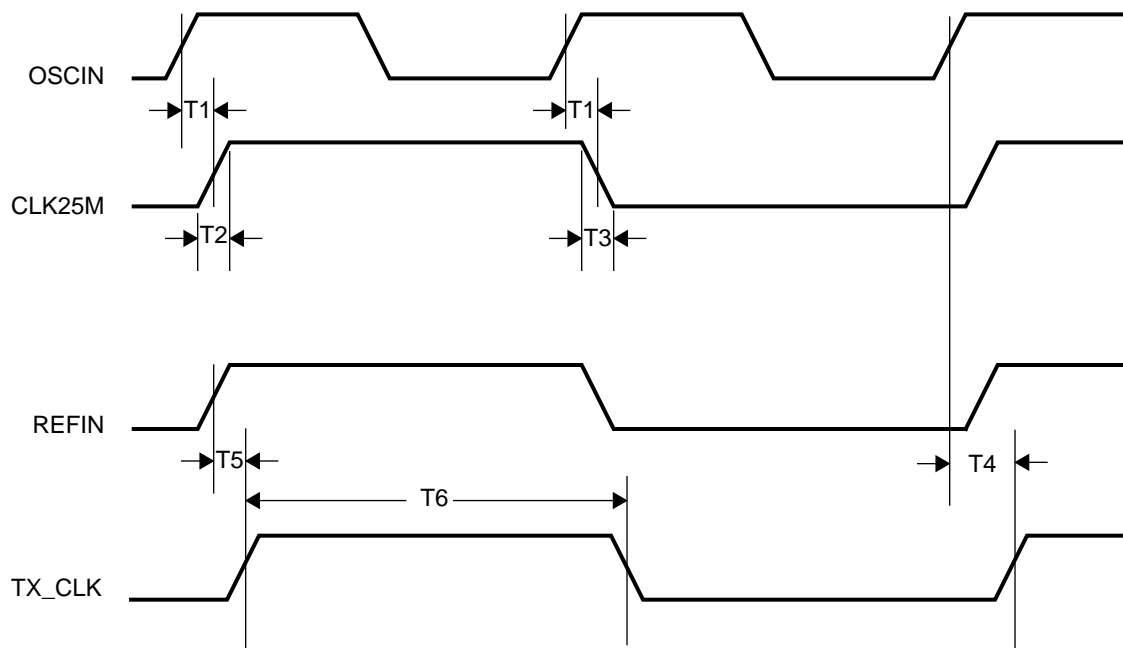

8.0 Electrical Specifications (Continued)

8.4 MII Serial Management Timing

8.4.1 MII Serial Management Timing

Parameter	Description	Notes	Min	Typ	Max	Units
T1	MDC to MDIO (Output) Delay Time		0		300	ns
T2	MDIO (Input) to MDC Set Time		10			ns
T3	MDIO (Input) to MDC Hold Time		10			ns
T4	MDC Frequency				2.5	MHz

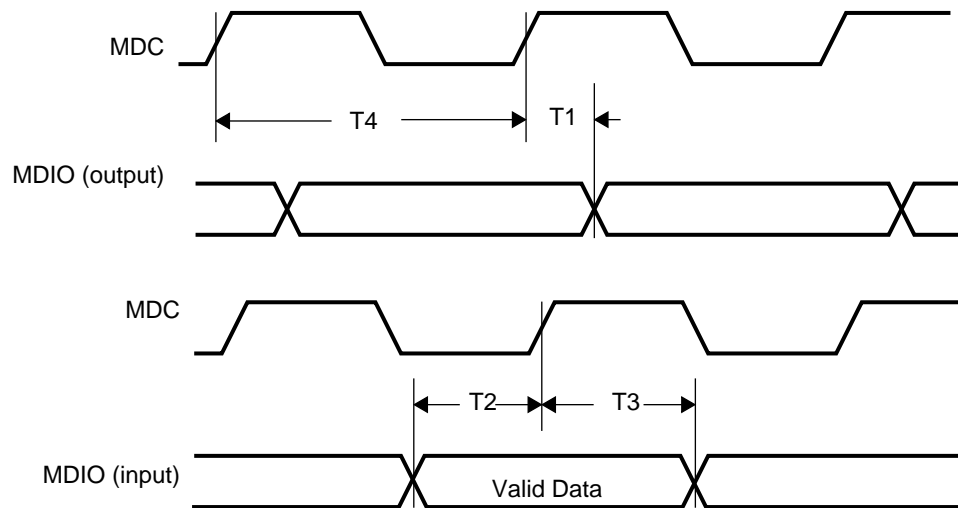

8.0 Electrical Specifications (Continued)

8.5 100 Mb/s AC Timing

8.5.1 100 Mb/s MII Transmit Timing

Parameter	Description	Notes	Min	Typ	Max	Units
T1	TXD[3:0], TX_EN, TX_ER Data Setup to TX_CLK	100 Mb/s Translational mode (Normal)	10			ns
	TXD[4:0] Data Setup to TX_CLK	100 Mb/s Transparent mode (BP_4B5B)	10			ns
	TXD[4:0] Data Setup to TX_CLK	100 Mb/s Phaser mode (BP_ALIGN)	10			ns
T2	TXD[3:0], TX_EN, TX_ER Data Hold from TX_CLK	100 Mb/s Translational mode (Normal)	-2			ns
	TXD[4:0] Data Hold from TX_CLK	100 Mb/s Transparent mode (BP_4B5B)	-2			ns
	TXD[4:0] Data Hold from TX_CLK	100 Mb/s Phaser mode (BP_ALIGN)	-2			ns

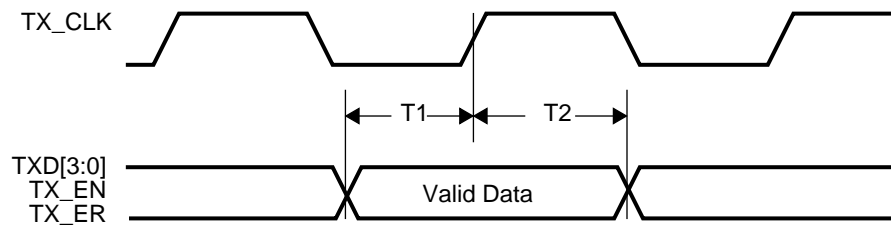

8.0 Electrical Specifications (Continued)

8.5.2 100 Mb/s MII Receive Timing

Parameter	Description	Notes	Min	Typ	Max	Units
T1	RX_EN to RX_CLK, RXD[3:0], RX_ER, RX_DV Active	All 100 Mb/s modes	0		20	ns
T2	RX_EN to RX_CLK, RXD[3:0], RX_ER, RX_DV Tri-State	All 100 Mb/s modes	0		30	ns
T3	RX_CLK to RXD[3:0], RX_DV, RX_ER Delay	100 Mb/s Translational mode (Normal)	10		30	ns
	RX_CLK to RXD[4:0], RX_DV, Delay	100 Mb/s Transparent mode (BP_4B5B)	10		30	ns
	RX_CLK to RXD[4:0], RX_DV, Delay	100 Mb/s Phaser mode (BP_ALIGN), Note 2	10		30	ns
T4	RX_CLK Duty Cycle	All 100 Mb/s modes	35		65	%

Note: RXD[3:0], RX_DV, and RX_ER are clocked out of the DP83840A on the falling edge of RX_CLK. However, in order to specify this parameter without the RX_CLK duty cycle affecting it, the timing is taken from the previous rising edge of RX_CLK.

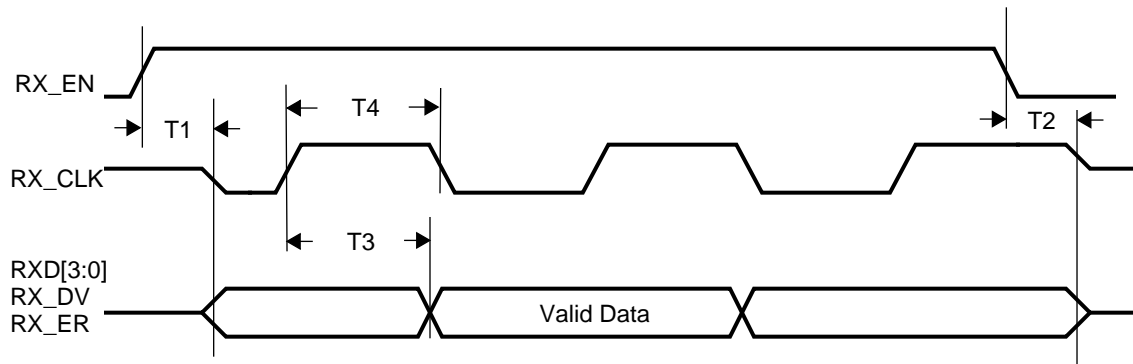

8.0 Electrical Specifications (Continued)

8.5.3 100 Mb/s Transmit Packet Timing

Parameter	Description	Notes	Min	Typ	Max	Units
T1	TX_CLK to TD+/- Latency	100 Mb/s Translational mode (Normal)			3.0	bits
		100 Mb/s Transparent mode (BP_4B5B)			3.0	bits
		100 Mb/s Phaser mode (BP_ALIGN)			3.0	bits

Note: Latency is determined by measuring the time from the first rising edge of TX_CLK occurring after the assertion of TX_EN to the first bit of the "J" code group as output from the TD+/- pins. 1 bit time = 10ns in 100 Mb/s mode

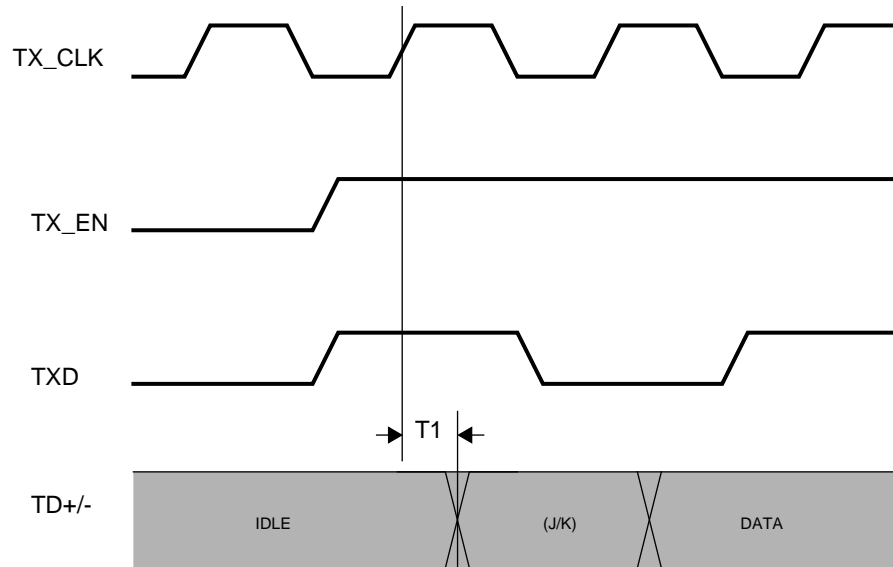

8.5.4 100 Mb/s Transmit Packet Timing

Parameter	Description	Notes	Min	Typ	Max	Units
T1	TX_CLK to TD+/- deassertion	100 Mb/s Translational mode (Normal)			30	ns
		100 Mb/s Transparent mode (BP_4B5B)			30	ns
		100 Mb/s Phaser mode (BP_ALIGN)			30	ns

Note: De-assertion is determined by measuring the time from the first rising edge of TX_CLK occurring after the de-assertion of TX_EN to the first bit of the "T" code group as output from the TD+/- pins. 1 bit time = 10ns in 100 Mb/s mode

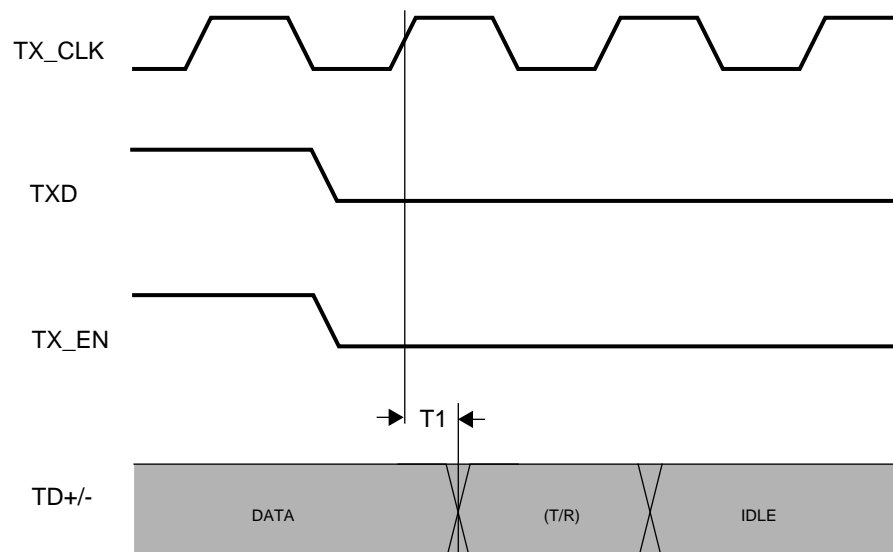

8.0 Electrical Specifications (Continued)

8.5.5 100 Mb/s Receive Packet Timing

Parameter	Description	Notes	Min	Typ	Max	Units
T1	Carrier Sense on Delay	100 Mb/s Translational mode (Normal)			175	ns
		100 Mb/s Transparent mode (BP_4B5B)			175	ns
T2	Receive Data Latency	100 Mb/s Translational mode (Normal)			21	bits
		100 Mb/s Transparent mode (BP_4B5B)			21	bits
		100 Mb/s Phaser mode (BP_ALIGN)			10	bits

Note: Carrier Sense On Delay is determined by measuring the time from the first bit of the "J" code group to the assertion of Carrier Sense.
1 bit time = 10ns in 100 Mb/s mode

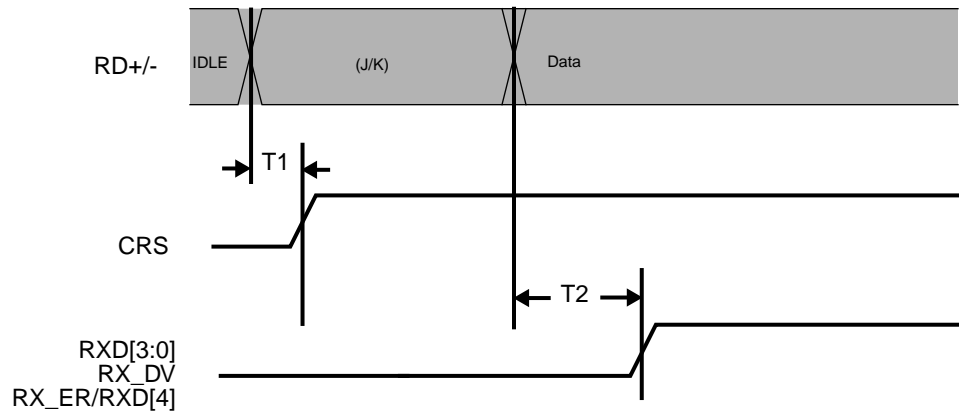

8.5.6 100 Mb/s Receive Packet Timing

Parameter	Description	Notes	Min	Typ	Max	Units
T1	Carrier Sense off Delay	100 Mb/s Translational mode (Normal)			135	ns
		100 Mb/s Transparent mode (BP_4B5B)			135	ns

Note: Carrier Sense Off Delay is determined by measuring the time from the first bit of the "IDLE" code group to the de-assertion of Carrier Sense.
1 bit time = 10ns in 10 Mb/s mode

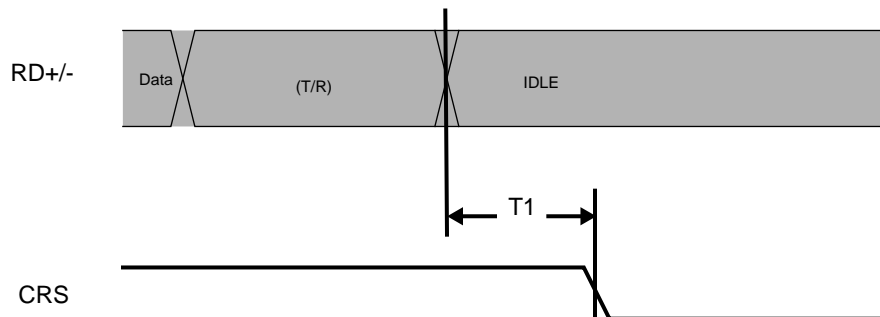

8.0 Electrical Specifications (Continued)

8.6 10 Mb/s AC Timing

8.6.1 10 Mb/s Transmit Timing (Start of Packet)

Parameter	Description	Notes	Min	Typ	Max	Units
T1	Transmit Enable Setup Time from the Rising Edge of TXC	10 Mb/s nibble mode	20			ns
		10 Mb/s serial mode	20			ns
T2	Transmit Data Setup Time from the Rising Edge of TXC	10 Mb/s nibble mode	20			ns
		10 Mb/s serial mode	20			ns
T3	Transmit Data Hold Time from the Rising Edge of TXC	10 Mb/s nibble mode	-2			ns
		10 Mb/s serial mode	-2			ns
T4	Transmit Latency (Rising Edge of TXC to TXU+/-)	10 Mb/s nibble mode			6.8	bits
		10 Mb/s serial mode			2.5	bits

Note: 1 bit time = 100ns in 10 Mb/s mode for both nibble and serial operation.

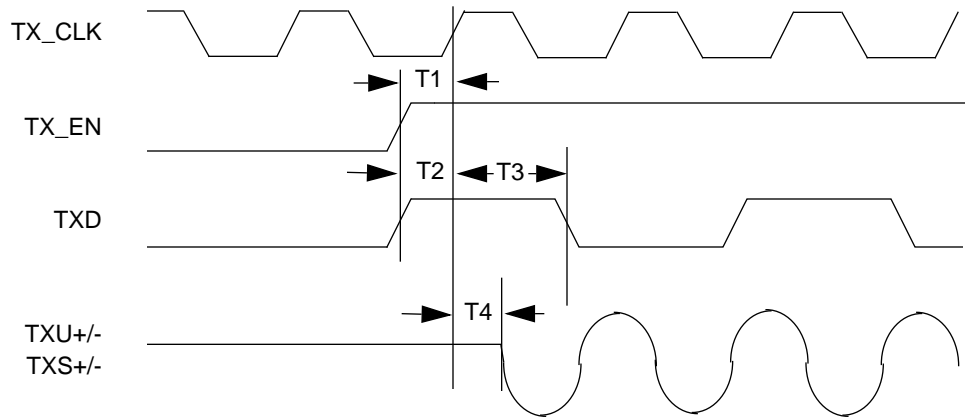

8.0 Electrical Specifications (Continued)

8.6.2 10 Mb/s Transmit Timing (End of Packet)

Parameter	Description	Notes	Min	Typ	Max	Units
T1	Transmit Enable Hold Time from Rising Edge of TX_CLK	10 Mb/s nibble mode	-2			ns
		10 Mb/s serial mode	-2			ns
T2	End of Packet High Time (with '0' ending bit)	10 Mb/s nibble mode	250			ns
		10 Mb/s serial mode	250			ns
T3	End of Packet High Time (with '1' ending bit)	10 Mb/s nibble mode	250			ns
		10 Mb/s serial mode	250			ns

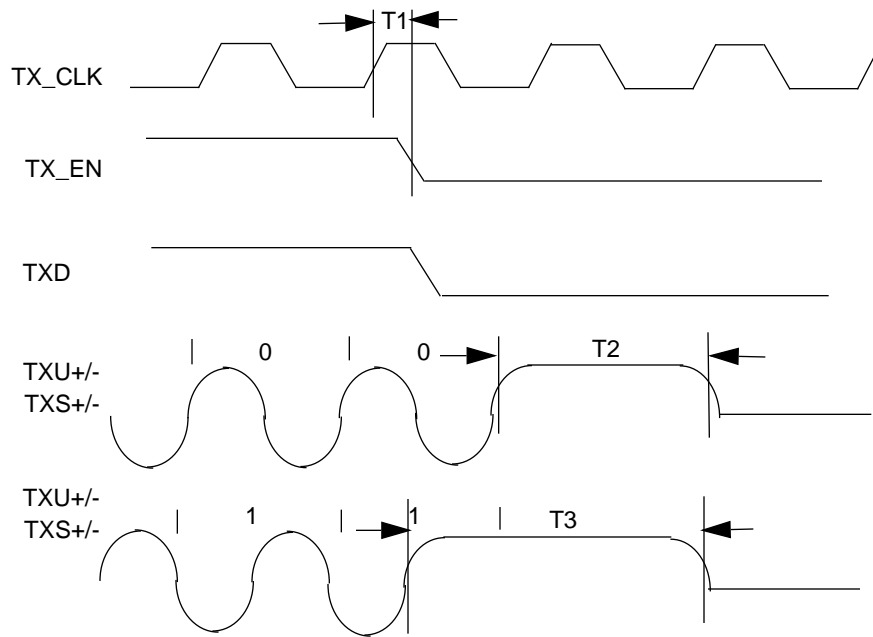

8.0 Electrical Specifications (Continued)

8.6.3 10 Mb/s Receive Timing (Start of Packet)

Parameter	Description	Notes	Min	Typ	Max	Units
T1	Carrier Sense Turn On Delay (RXI+/- to CRS)	10 Mb/s nibble mode			1	μ s
		10 Mb/s serial mode			1	μ s
T2	Decoder Acquisition Time	10 Mb/s nibble mode			2.6	μ s
		10 Mb/s serial mode			2.2	μ s
T3	Receive Data Latency	10 Mb/s nibble mode			17.3	bits
		10 Mb/s serial mode			10	bits
T4	SFD Latency	10 Mb/s nibble mode			10	bits
		10 Mb/s serial mode			0.8	bits
T5	RX_CLK to RXD Delay Time	10 Mb/s nibble mode	-10		20	ns
		10 Mb/s serial mode	-10		60	ns

Note: 10 Mb/s receive Data Latency is measured from first bit of preamble on the wire to the assertion of RX_DV
 Note: 1 bit time = 100ns in 10 Mb/s mode for both nibble and serial operation.

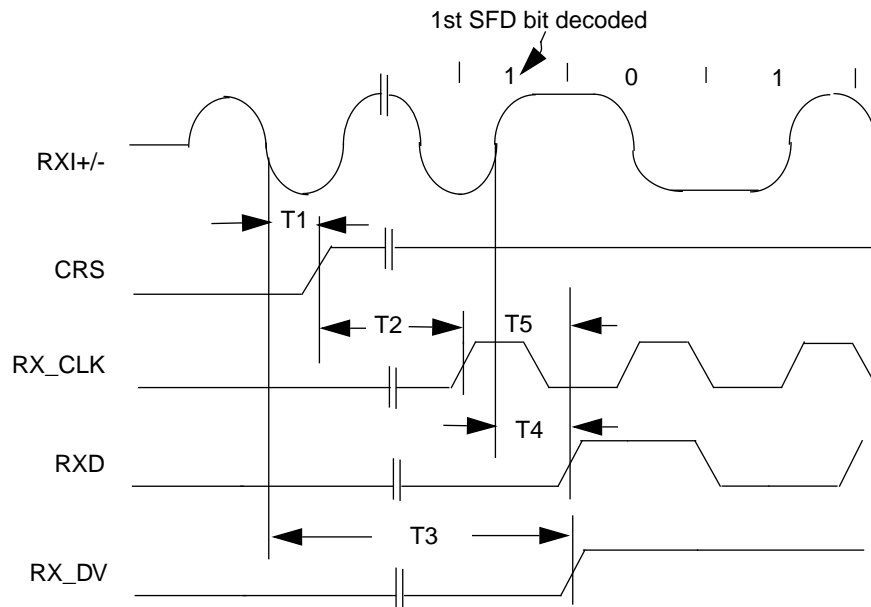

8.0 Electrical Specifications (Continued)

8.6.4 10 Mb/s Receive Timing (End of Packet)

Parameter	Description	Notes	Min	Typ	Max	Units
T1	Carrier Sense Turn Off Delay	10 Mb/s nibble mode			1.1	μ s
		10 Mb/s serial mode			150	ns

Note: The de-assertion of CRS is asynchronous and is therefore not directly measured.

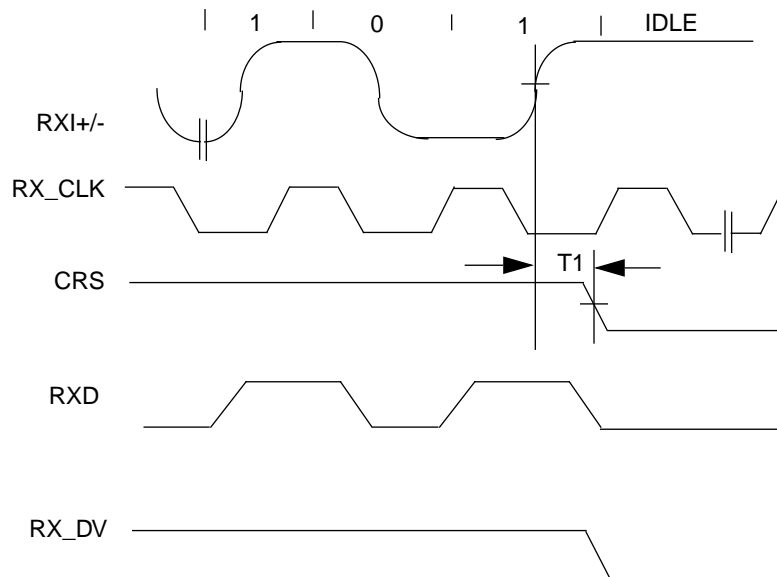

8.0 Electrical Specifications (Continued)

8.6.5 Heartbeat Timing

Parameter	Description	Notes	Min	Typ	Max	Units
T1	CD Heartbeat Delay	10 Mb/s nibble mode		1.6		μs
		10 Mb/s serial mode	0.6	1.4	1.6	μs
T2	CD Heartbeat Duration	10 Mb/s nibble mode		1.3		μs
		10 Mb/s serial mode	0.5	1.3	1.5	μs

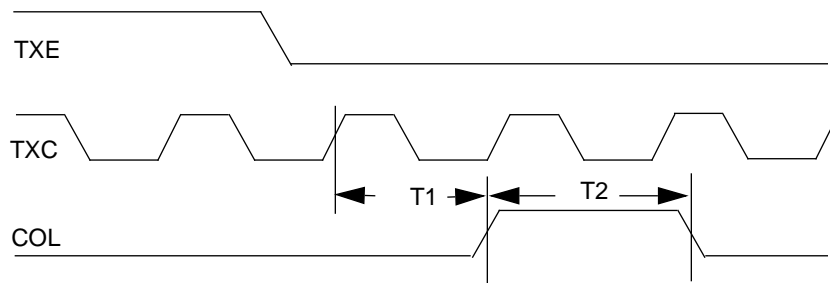

8.6.6 10 Mb/s Jabber Timing

Parameter	Description	Notes	Min	Typ	Max	Units
T1	Jabber Activation Time	10 Mb/s nibble mode	20	26	150	ms
		10 Mb/s serial mode	20	26	150	ms
T2	Jabber Deactivation Time	10 Mb/s nibble mode	250	730	750	ms
		10 Mb/s serial mode	250	730	750	ms

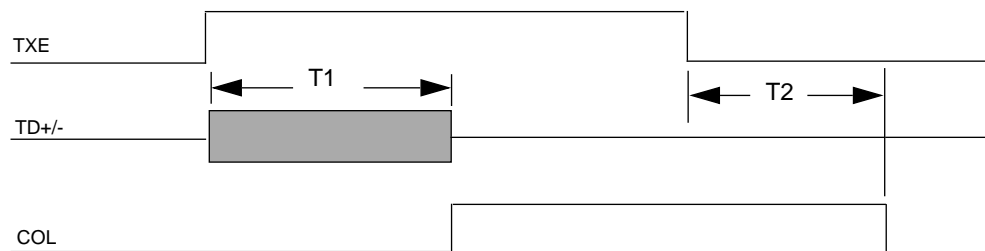

8.0 Electrical Specifications (Continued)

8.6.7 10BASE-T Normal Link Pulse Timing

Parameter	Description	Notes	Min	Typ	Max	Units
T1	Clock, Data Pulse Width		80	100	130	ns
T2	Clock Pulse to Clock Pulse Period		8	16	24	ms

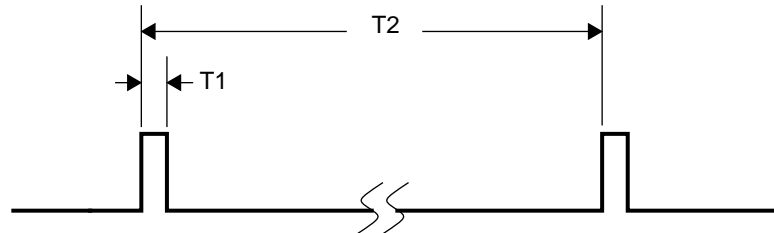

8.7 Auto-Negotiation Fast Link Pulse (FLP) Timing

8.7.1 Auto-Negotiation Fast Link Pulse (FLP) timing

Parameter	Description	Notes	Min	Typ	Max	Units
T1	Clock, Data Pulse Width		80	100	130	ns
T2	Clock Pulse to Clock Pulse Period		111	125	139	μ s
T3	Clock Pulse to Data Pulse Period	Data = 1	55.5		69.5	μ s
T4	Number of Pulses in a Burst		17		33	#
T5	Burst Width			2		ms
T6	FLP Burst to FLP Burst Period		8		24	ms

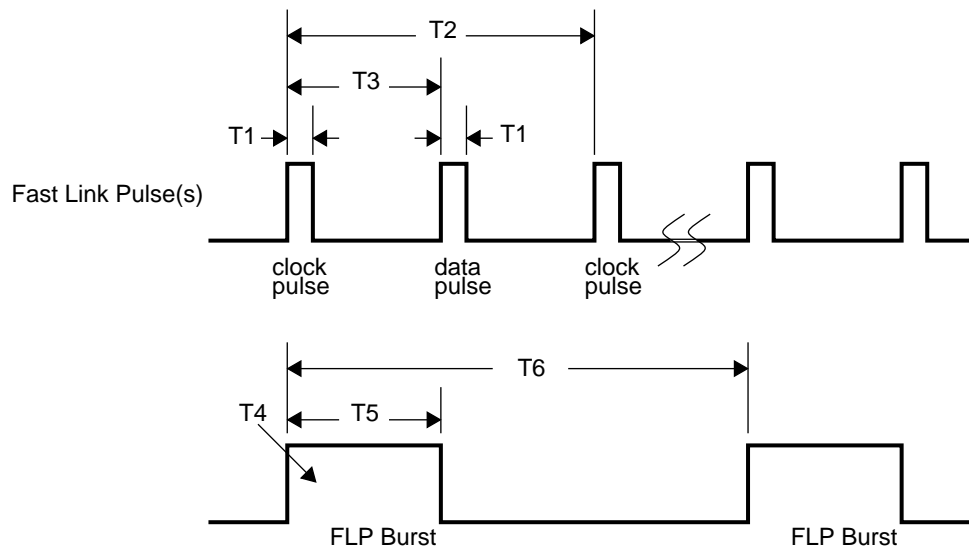

8.0 Electrical Specifications (Continued)

8.8 CRM (Clock Recovery Module) Timing

8.8.1 CRM Window Timing

Parameter	Description	Notes	Min	Typ	Max	Units
T1	CRM Sampling Window	(Note 1)	-1		1	ns

Note 1: The CRM Sampling Window is a measure of the PLL's ability to recover data even with a high degree of jitter without error.

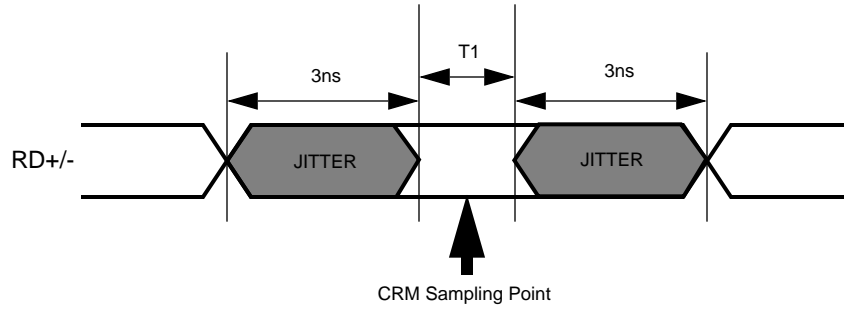

8.8.2 CRM Acquisition Time

Parameter	Description	Notes	Min	Typ	Max	Units
T1	CRM Acquisition	100 Mb/s			250	μ s

Note: The Clock Generation Module (CGM) must be stable for at least 100 μ s before the Clock Recovery Module (CRM) can lock to receive data.

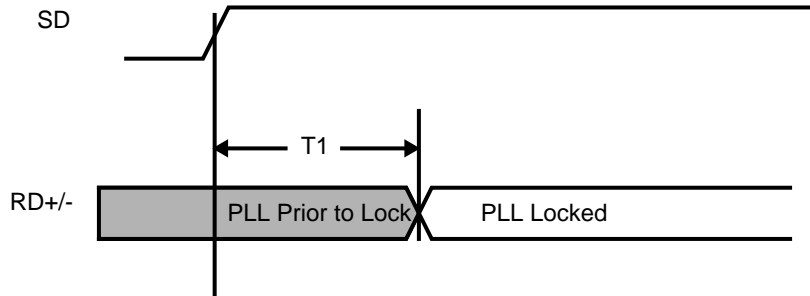

8.0 Electrical Specifications (Continued)

8.9 Reset Timing

8.9.1 Hardware Reset Timing

Parameter	Description	Notes	Min	Typ	Max	Units
T1	Internal Reset Time		500			μs
T2	Hardware RESET Pulse Width		1			μs
T3	Post Reset Stabilization time prior to MDC preamble for register accesses	MDIO is pulled high for 32 bit serial management initialization	500			μs
T4	Hardware Configuration Latch-in Time from the Deassertion of Reset (either soft or hard)	Hardware Configuration Pins are described in section 3.10		800		ns
T5	Hardware Configuration pins transition to output drivers	It is important to choose pull-up and/or pull-down resistors for each of the hardware configuration pins that provide fast RC time constants in order to latch-in the proper value prior to the pin transitioning to an output driver		800		ns

Note: Software Reset should be initiated no sooner than $500\mu\text{s}$ after power-up or the deassertion of hardware reset.

Note: The timing for Hardware Reset Option 2 is equal to parameter T1 plus parameter T2 ($501\mu\text{s}$ total).

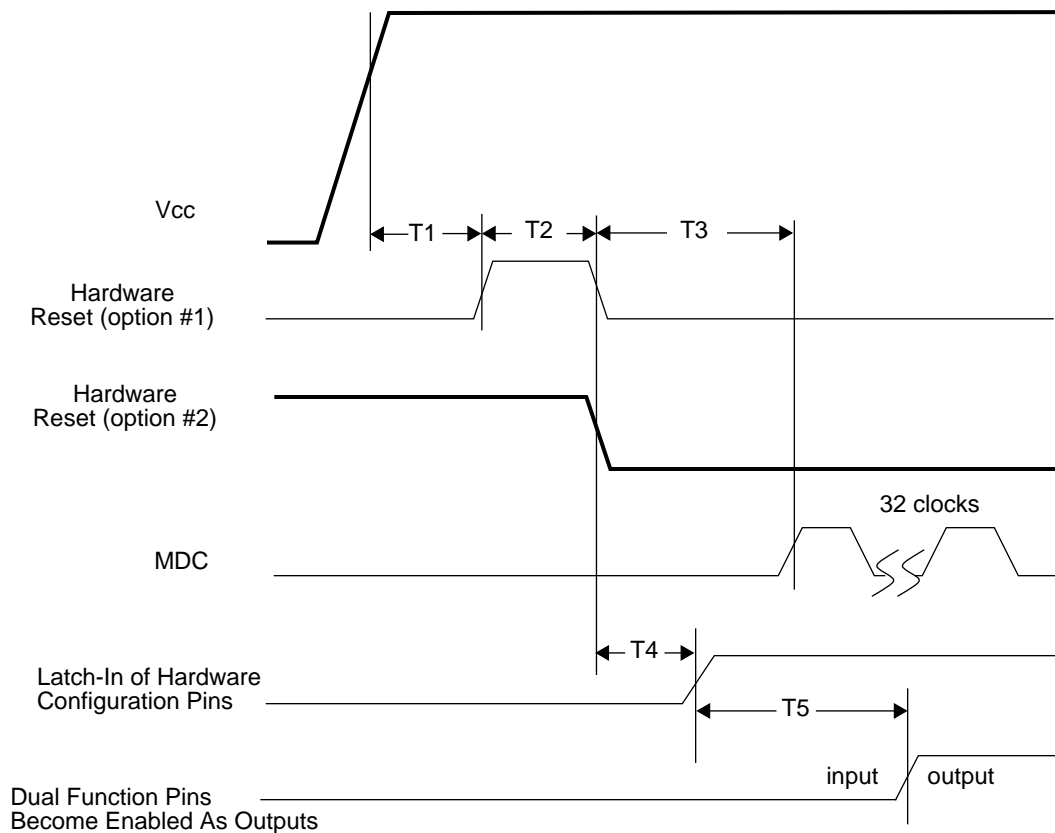

8.0 Electrical Specifications (Continued)

8.10 Loopback Timing

8.10.1 10 Mb/s and 100 Mb/s Loopback Timing

Parameter	Description	Notes	Min	Typ	Max	Units
T1	TX_EN to RX_DV Loopback	100 Mb/s (note 1), (note2), (note3)			240	ns
		10 Mb/s serial mode (note 4)			250	ns
		10 Mb/s nibble mode (internal loopback)			2	μs
		10 Mb/s nibble mode (normal operation)			2	μs

Note 1: The 100BASE-X PMD Loopback option timing is dependent on the external transceiver loopback timing and is therefore not defined herein.

Note 2: The TD+/- outputs of the DP83840A can be enabled or disabled during loopback operation via the LBK_XMT_DS bit (bit 5 of the LBREMR register).

Note 3: Due to the nature of the descrambler function, all 100BASE-X Loopback modes, with the exception of Remote Loopback, will cause an initial "dead-time" of up to 750μs during which time no data will be present at the receive MII outputs. The 100BASE-X timing shown here in section 6.3.16 is based on device delays after the initial 750μs "dead-time"

Note 4: During 10BASE-T loopback (serial or nibble mode) both the TXU+/- and TXS+/- outputs remain inactive.

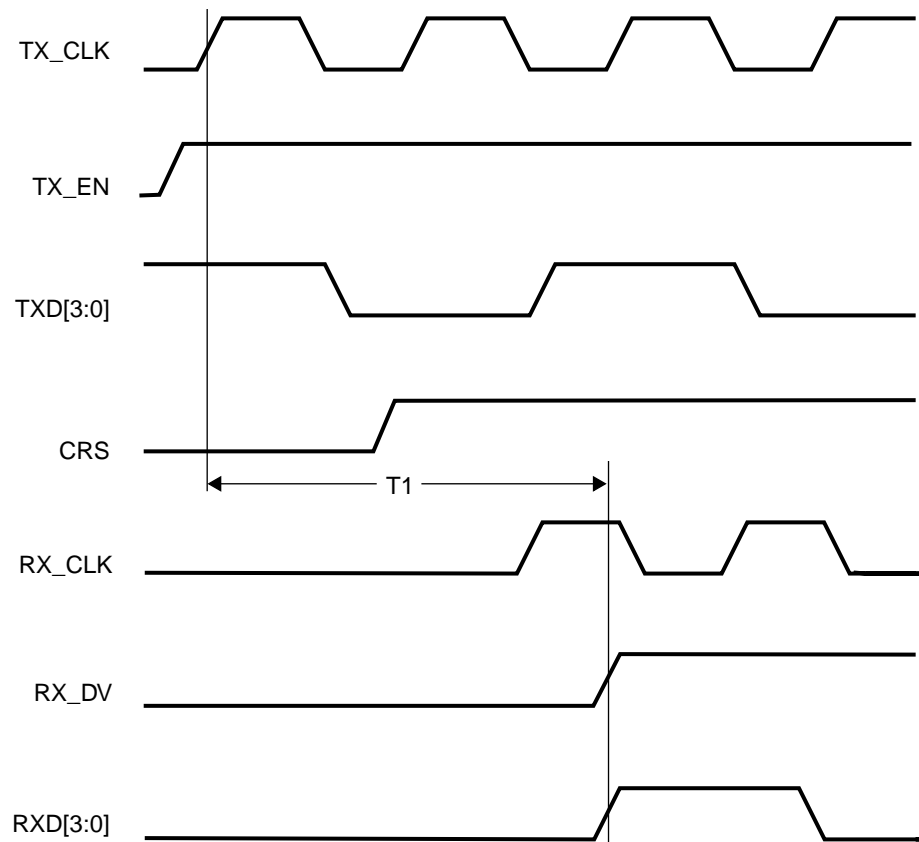

8.0 Electrical Specifications

8.10.2 Remote Loopback

Parameter	Description	Notes	Min	Typ	Max	Units
T1	Remote Loopback	100 Mb/s only			25	ns

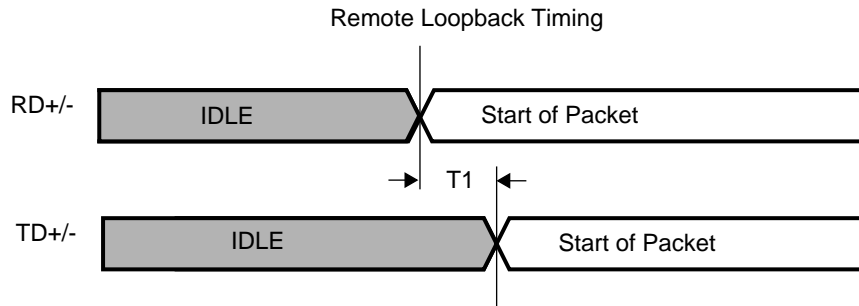

8.11 Isolation Timing

8.11.1 PHY Isolation Timing

Parameter	Description	Notes	Min	Typ	Max	Units
T1	From software clear of bit 10 in the BMCR register to the transition from Isolate to Normal Mode				100	μ s
T2	From Deassertion of S/W or H/W Reset to transition from Isolate to Normal mode				500	μ s

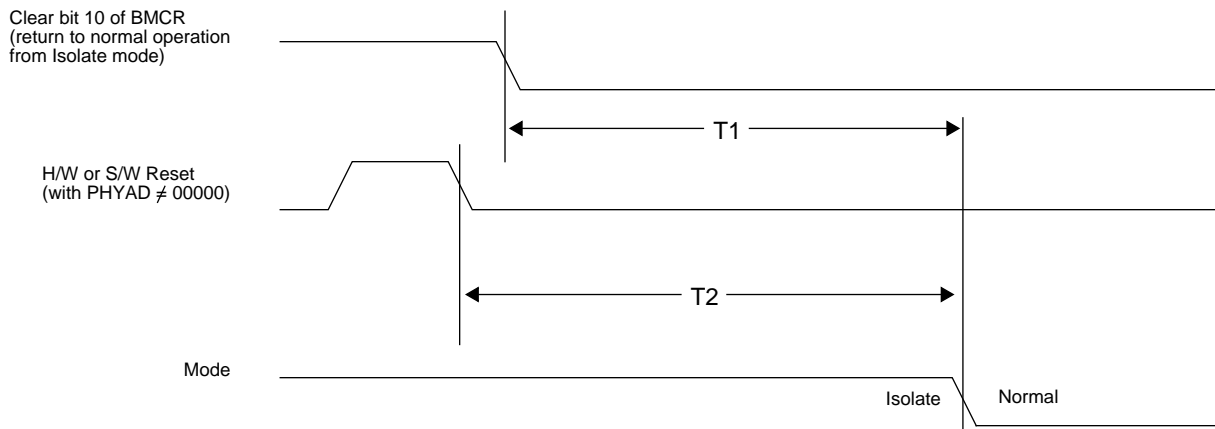

7.0 Package Specification

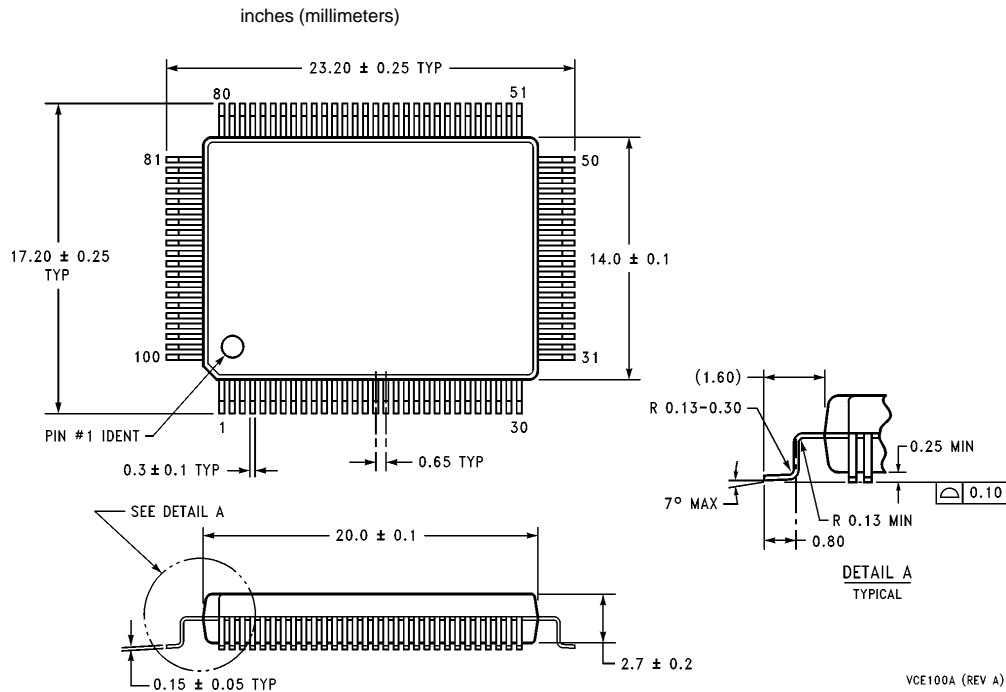

100-Lead (14mm x 20mm) Molded Plastic Quad Flatpak, JEDEC
 Order Number DP83840
 NS Package Number VCE100A

LIFE SUPPORT POLICY

NATIONAL'S PRODUCTS ARE NOT AUTHORIZED FOR USE AS CRITICAL COMPONENTS IN LIFE SUPPORT DEVICES OR SYSTEMS WITHOUT THE EXPRESS WRITTEN APPROVAL OF THE PRESIDENT OF NATIONAL SEMICONDUCTOR CORPORATION. As used herein:

1. Life support devices or systems we do or systems which, (a) are intended for surgical implant into the body, or (b) support or sustain life, and whose failure to perform, when properly used in accordance with instructions for use provided in the labeling, can be reasonably expected to result in a significant injury to the user.
2. A critical component is any component of a life support device or system whose failure to perform can be reasonably expected to cause the failure of the life support device or system, or to affect its safety or effectiveness.



National Semiconductor Corporation

1111 West Bardin Road
 Arlington, TX 76017

Tel: 1(800) 272-9959

Fax: 1(800) 737-7018

National Semiconductor Corporation Europe

Fax: (+49) 0-180-530 85 86

Email: cnjwge@tevm2.nsc.com

Duetsch Tel: (+49) 0-180-530 85 86

English Tel: (+49) 0-180-532 78 32

Francais Tel: (+49) 0-180-532 93 58

Italiano Tel: (+49) 0-180-534 16 80

National Semiconductor Corporation Japan Ltd.

Tel: 81-043-299-2308

Fax: 81-043-299-2408

National Semiconductor Corporation Hong Kong Ltd.

13th Floor, Straight Block,
 Ocean Centre, 5 Canton Rd.,
 Tsimshatsui, Kowloon
 Hong Kong
 Tel: (852) 2737-1600
 Fax: (852) 2736-9960