



82562 Family Platform LAN Connect Fast Ethernet Controllers

Product Brief

Product Description

The Intel® 82562 family of controllers are highly integrated Platform LAN Connect (PLC) devices combining 10BASE-T and 100BASE-TX physical layer capabilities and providing a core ingredient of the enabling solution for the integrated networking connectivity in Intel® I/O Controller Hub (ICH2/3/4) based platforms. Both support a single interface fully compliant with the IEEE 802.3/802.3u standard. The IEEE 802.3u standard for 100BASE-TX defines networking over two pairs of Category 5 unshielded twisted pair cable. The 82562ET and 82562EM comply with the IEEE 802.3u Auto-Negotiation (and 100BASE-TX) standard and the IEEE 802.3x Full Duplex Flow Control standard.

The combination 82562 device with ICH2/3/4 LAN solution enables a 32-bit PCI device that features enhanced scatter-gather bus mastering capabilities allowing high-speed data transfers over the PCI bus. In addition, these bus mastering capabilities enable the LAN solution to process high-level commands and perform multiple operations, thereby offloading communications tasks from the system CPU. Two large transmit and receive FIFOs are also included in the architecture to enhance performance while minimizing the use of system resources.

Target applications include but are not limited to LAN on Motherboard (LOM) and Communications and Networking Riser (CNR) form factors targeted at the value segment. These designs could include embedded and PC target applications requiring reliable 10/100 Mbps LAN capabilities. The 82562 family enables additional enterprise management capabilities beyond this baseline. When combined, the 82562, the 82562 software, and the embedded LAN capability in the ICH2/3/4 make up Intel's newest high quality 10/100 Mbps network solution, the Intel® PRO/100 VE/VM Network Connection.

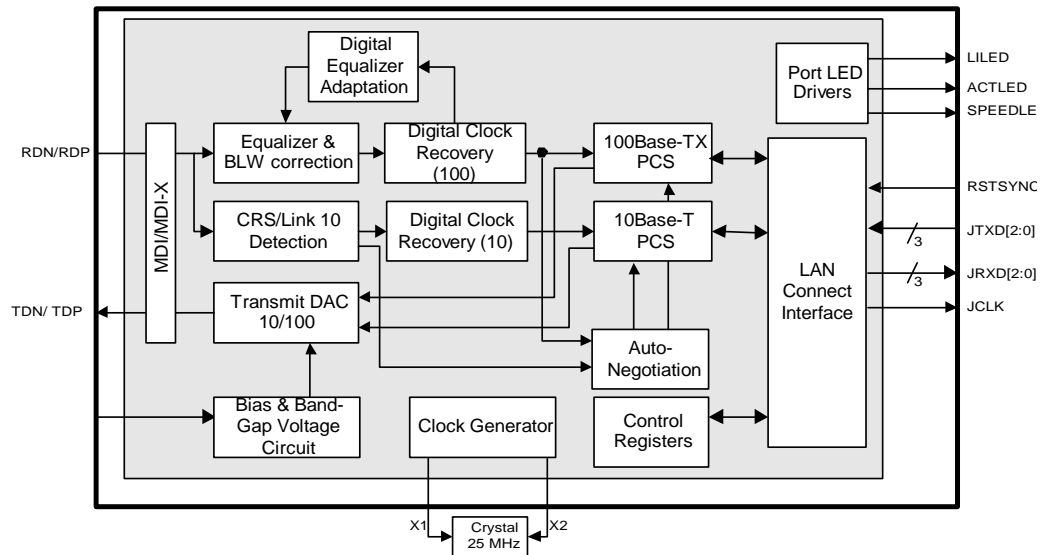

Hardware Product Features

- IEEE 802.3 10BASE-T/100BASE-TX compliant physical layer interface
- IEEE 802.3u Auto-Negotiation support
- Digital Adaptive Equalization control
- Link status interrupt capability
- XOR Tree mode support for board testing
- 3-port LED support (speed, link and activity)
- 10BASE-T auto-polarity correction
- Diagnostic loopback mode
- 1:1 transmit transformer ratio support
- Low power (less than 300 mW in active transmit mode)
- Reduced power in “unplugged mode” (less than 50 mW)
- Automatic detection of “unplugged mode”
- 3.3 V device
- Platform LAN connect interface support

Software Product Features

- Intel® SingleDriver™ technology (10/100 Mbps support)
- Certified and validated support for most common operating systems
- Instrumentation support for CIM/WBEM, SNMP, DMI, PXE 2.0
- Intel® PROSet Utility support for installation and configuration
- Alert on LAN* Software Developer Kit (SDK) and sample code (82562EM only)

Applications

The 82562 device family is designed for use in the following applications.

- LAN on Motherboard (LOM) implementation
- Card and Network Riser (CNR) based Network Interface Card (NIC) adapters
- Embedded applications
- Networking systems

Characteristics

Electrical	
Power Supply	3.3 V \pm 5%
Power Dissipation	300 mW (typical)
Environmental	
Operating temperature	0 C to 85 C (maximum)
Storage temperature	-65 C to 140 C
Physical	
Package	See Package Type in Feature Matrix

Feature Matrix

The 82562 device family consists of six different versions: ET, EM, EP, EX, and EZ.

Features	ET	EM	EP	EX	EZ	Comments
Footprint compatible with the Intel® 82540 Gigabit Ethernet controller				X	X	Enables single board design to accommodate Gigabit or 10/100 Mbps LAN solution
Alert on LAN 1.0 support		X	X	X		Enables remote manageability support
3.3 V device	X	X	X	X	X	
3-port LED support (speed, link, and activity)	X	X	X	X	X	
WfM Baseline and NetPC Specification compliant	X	X	X	X	X	
ACPI support	X	X	X	X	X	
Magic Packet filtering for Wake on LAN support	X	X	X	X	X	
ARP and flexible frame support	X	X	X	X	X	
Automatic detectin of "unplugged mode"	X	X	X	X	X	Allows additional power down beyond ACPI for reduced power consumption
Low power (less than 300 mW in active transmit mode)	X	X	X	X	X	Minimizes power consumption
Platform LAN connect interface support	X	X	X	X	X	
Low power 3.3 V device	X	X	X	X	X	
Package type:						
• 48-pin SSOP	X	X				
• 64-pin PBGA			X			
• 196-pin PBGA				X	X	

Information in this document is provided in connection with Intel® products. No license, express or implied, by estoppel or otherwise, to any intellectual property rights is granted by this document. Except as provided in Intel's Terms and Conditions of Sale for such products, Intel assumes no liability whatsoever, and Intel disclaims any express or implied warranty, relating to sale and/or use of Intel® products including liability or warranties relating to fitness for a particular purpose, merchantability, or infringement of any patent, copyright or other intellectual property right. Intel products are not intended for use in medical, life saving, or life sustaining applications.

Intel may make changes to specifications and product descriptions at any time, without notice.

Contact your local Intel sales office or your distributor to obtain the latest specifications and before placing your product order.

Copyright © 2002, Intel Corporation. All rights reserved.

* Third-party brands and names are the property of their respective owners.