



PRODUCT BRIEF

Z16C35

CMOS ISCC™ INTEGRATED SERIAL COMMUNICATIONS CONTROLLER

FEATURES

- Low Power CMOS Technology
- Two General-Purpose SCC Channels, Four DMA Channels; and Universal Bus Interface Unit.
- Software Compatible to the Zilog CMOS SCC
- Four DMA Channels; Two Transmit and Two Receive Channels to and from the SCC
- Four Gigabyte Address Range per DMA Channel
- Fly-by DMA Transfer Mode
- Programmable DMA Channel Priorities
- Independent DMA Register Set
- A Universal Bus Interface Unit Providing Simple Interface to Most CPUs Multiplexed or Non-Multiplexed Bus; Compatible with 680x0 and 8x86 CPUs.
- 32-Bit Addresses Multiplexed to 16-Pin Address/Data Lines
- 68-Pin PLCC
- Supports all Zilog CMOS SCC Features.
- Two Independent, 0 to 4.0 Mbit/sec, Full-Duplex Channels, each with a Separate Crystal Oscillator, Baud Rate Generator, and Digital Phase-Locked Loop Circuit for Clock Recovery.
- Multi-Protocol Operation Under Program Control; Programmable for NRZ, NRZI, or FM Data Encoding.
- Asynchronous Mode with Five to Eight Bits and One, One and One-Half, or Two Stop Bits Per Character; Programmable Clock Factor; Break Detection and Generation; Parity, Overrun, and Framing Error Detection.
- Synchronous Mode with Internal or External Character Synchronization on One or Two Synchronous Characters and CRC Generation and Checking with CRC-16 or CRC-CCITT Preset to Either 1's or 0's.
- SDLC/HDLC Mode with Comprehensive Frame-Level Control, Automatic Zero Insertion and Deletion, I-Field Residue Handling, Abort Generation and Detection, CRC Generation and Checking, and SDLC Loop Mode Operation.
- Full CMOS SCC Register Set
- 10 and 16 MHz Speeds Suitable for T1 Full Duplex Operation

GENERAL DESCRIPTION

The Z16C35 ISCC™ is a CMOS Superintegrated device with a flexible Bus Interface Unit (BIU) connecting a built-in Direct Memory Access (DMA) cell to the CMOS Serial Communications Control (SCC) cell.

The ISCC is a dual-channel, multi-protocol data communications peripheral which easily interfaces to CPUs with either multiplexed or non-multiplexed address and data buses. The advanced CMOS process offers lower power consumption, higher performance, and superior noise immunity. The programming flexibility of the internal registers allow the ISCC to be configured for a wide variety of serial communications applications. The many on-chip

features such as, streamlined bus interface, four channel DMA, baud rate generators, digital phase-locked loops, and crystal oscillators dramatically reduce the need for external logic.

The ISCC can address up to 4 gigabytes per DMA channel by using the /UAS and /AS signals to strobe out 32-bit multiplexed addresses.

The ISCC handles asynchronous formats, synchronous byte-oriented protocols such as IBM Bisync, and synchronous bit-oriented protocols such as HDLC and IBM SDLC.

GENERAL DESCRIPTION (Continued)

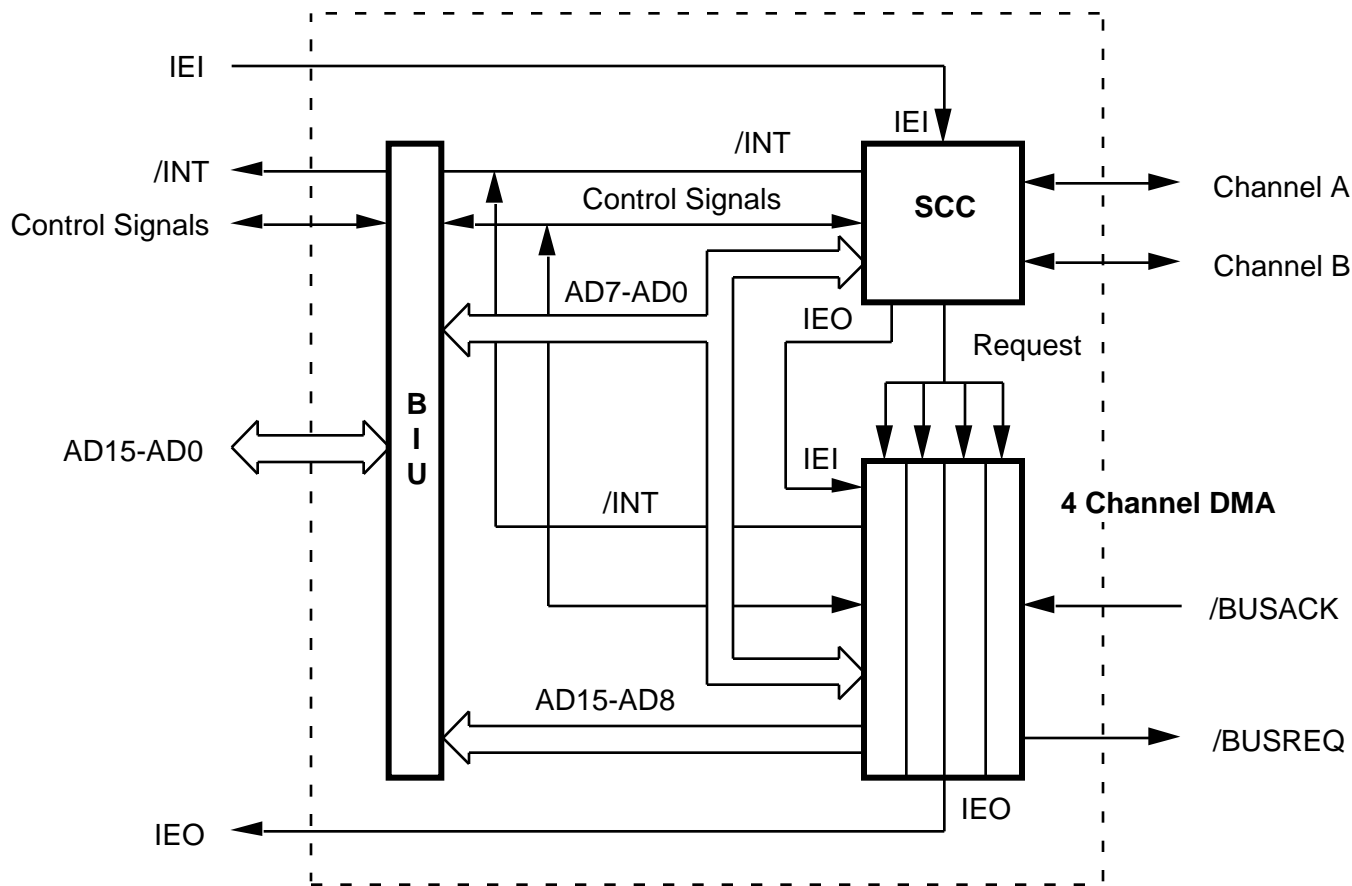

Z16C35 Functional Block Diagram

© 1997 by Zilog, Inc. All rights reserved. No part of this document may be copied or reproduced in any form or by any means without the prior written consent of Zilog, Inc. The information in this document is subject to change without notice. Devices sold by Zilog, Inc. are covered by warranty and patent indemnification provisions appearing in Zilog, Inc. Terms and Conditions of Sale only.

ZILOG, INC. MAKES NO WARRANTY, EXPRESS, STATUTORY, IMPLIED OR BY DESCRIPTION, REGARDING THE INFORMATION SET FORTH HEREIN OR REGARDING THE FREEDOM OF THE DESCRIBED DEVICES FROM INTELLECTUAL PROPERTY INFRINGEMENT. ZILOG, INC. MAKES NO WARRANTY OF MERCHANTABILITY OR FITNESS FOR ANY PURPOSE.

Zilog, Inc. shall not be responsible for any errors that may appear in this document. Zilog, Inc. makes no commitment to update or keep current the information contained in this document.

Zilog's products are not authorized for use as critical components in life support devices or systems unless a specific written agreement pertaining to such intended use is executed between the customer and Zilog prior to use. Life support devices or systems are those which are intended for surgical implantation into the body, or which sustains life whose failure to perform, when properly used in accordance with instructions for use provided in the labeling, can be reasonably expected to result in significant injury to the user.

Zilog, Inc. 210 East Hacienda Ave.
Campbell, CA 95008-6600
Telephone (408) 370-8000
Telex 910-338-7621
FAX 408 370-8056
Internet: <http://www.zilog.com>