

---

# ST-NXP Wireless

## IMPORTANT NOTICE

Dear customer,

As from August 2<sup>nd</sup> 2008, the wireless operations of NXP have moved to a new company, ST-NXP Wireless.

As a result, the following changes are applicable to the attached document.

- **Company name - Philips Semiconductors** is replaced with **ST-NXP Wireless**.
- **Copyright** - the copyright notice at the bottom of each page "© Koninklijke Philips Electronics N.V. 200x. All rights reserved", shall now read: "© ST-NXP Wireless 200x - All rights reserved".
- **Web site** - <http://www.semiconductors.philips.com> is replaced with <http://www.stnwireless.com>
- **Contact information** - the list of sales offices previously obtained by sending an email to [sales.addresses@www.semiconductors.philips.com](mailto:sales.addresses@www.semiconductors.philips.com), is now found at <http://www.stnwireless.com> under Contacts.

If you have any questions related to the document, please contact our nearest sales office. Thank you for your cooperation and understanding.

ST-NXP Wireless



# ISP1521

Hi-Speed Universal Serial Bus hub controller

Rev. 04 — 30 March 2006

Product data sheet



## 1. General description

---

The ISP1521 is a stand-alone Universal Serial Bus (USB) hub controller IC that complies with *Universal Serial Bus Specification Rev. 2.0*. It supports data transfer at high-speed (480 Mbit/s), full-speed (12 Mbit/s) and low-speed (1.5 Mbit/s).

The upstream facing port can be connected to a Hi-Speed USB host or hub or to an Original USB host or hub. If the upstream facing port is connected to a Hi-Speed USB host or hub, then the ISP1521 will operate as a Hi-Speed USB hub. That is, it will support high-speed, full-speed and low-speed devices connected to its downstream facing ports. If the upstream facing port is connected to an Original USB host or hub, then the ISP1521 will operate as an Original USB hub. That is, high-speed devices that are connected to its downstream facing ports will operate in full-speed mode instead.

The ISP1521 is a full hardware USB hub controller. All Original USB devices connected to the downstream facing ports are handled using a single Transaction Translator (TT), when operating in a cross-version environment. This allows the whole 480 Mbit/s upstream bandwidth to be shared by all the Original USB devices on its downstream facing ports.

The ISP1521 has seven downstream facing ports. If not used, ports 3 to 7 can be disabled. The vendor ID, product ID and string descriptors on the hub are supplied by the internal ROM; they can also be supplied by an external I<sup>2</sup>C-bus EEPROM or a microcontroller.

The ISP1521 is suitable for self-powered hub designs.

An analog overcurrent detection circuitry is built into the ISP1521, which can also accept digital overcurrent signals from external circuits; for example, Micrel MOSFET switch MIC2026. The circuitry can be configured to trip on a global or an individual overcurrent condition.

Each port comes with two status indicator LEDs.

Target applications of the ISP1521 are monitor hubs, docking stations for notebooks, internal USB hub for motherboards, hub for extending Intel Easy PCs, hub boxes, and so on.

# PHILIPS

## 2. Features

- Complies with:
  - ◆ *Universal Serial Bus Specification Rev. 2.0*
  - ◆ Advanced Configuration and Power Interface (ACPI), OnNow and USB power management requirements
- Supports data transfer at high-speed (480 Mbit/s), full-speed (12 Mbit/s) and low-speed (1.5 Mbit/s)
- Self-powered capability
- USB suspend mode support
- Configurable number of ports
- Internal Power-On Reset (POR) and low voltage reset circuit
- Port status indicators
- Integrates high performance USB interface device with hub handler, Philips Serial Interface Engine (SIE) and transceivers
- Built-in overcurrent detection circuit
- Individual or ganged power switching, individual or global overcurrent protection, and nonremovable port support by I/O pins configuration
- Simple I<sup>2</sup>C-bus (master or slave) interface to read device descriptor parameters, language ID, manufacturer ID, product ID, serial number ID and string descriptors from a dedicated external EEPROM, or to allow the microcontroller to set up hub descriptors
- Visual USB traffic monitoring (GoodLink) for the upstream facing port
- Uses 12 MHz crystal oscillator with on-chip Phase-Locked Loop (PLL) for low ElectroMagnetic Interference (EMI)
- Supports temperature range from -40 °C to +70 °C
- Available in LQFP80 package

## 3. Applications

- Monitor hubs
- Docking stations for notebooks
- Internal hub for USB motherboards
- Hub for extending Easy PCs
- Hub boxes

## 4. Ordering information

Table 1. Ordering information

Type number	Package		Version
	Name	Description	
ISP1521BE	LQFP80	plastic low profile quad flat package; 80 leads; body 12 × 12 × 1.4 mm	SOT315-1

5. Block diagram

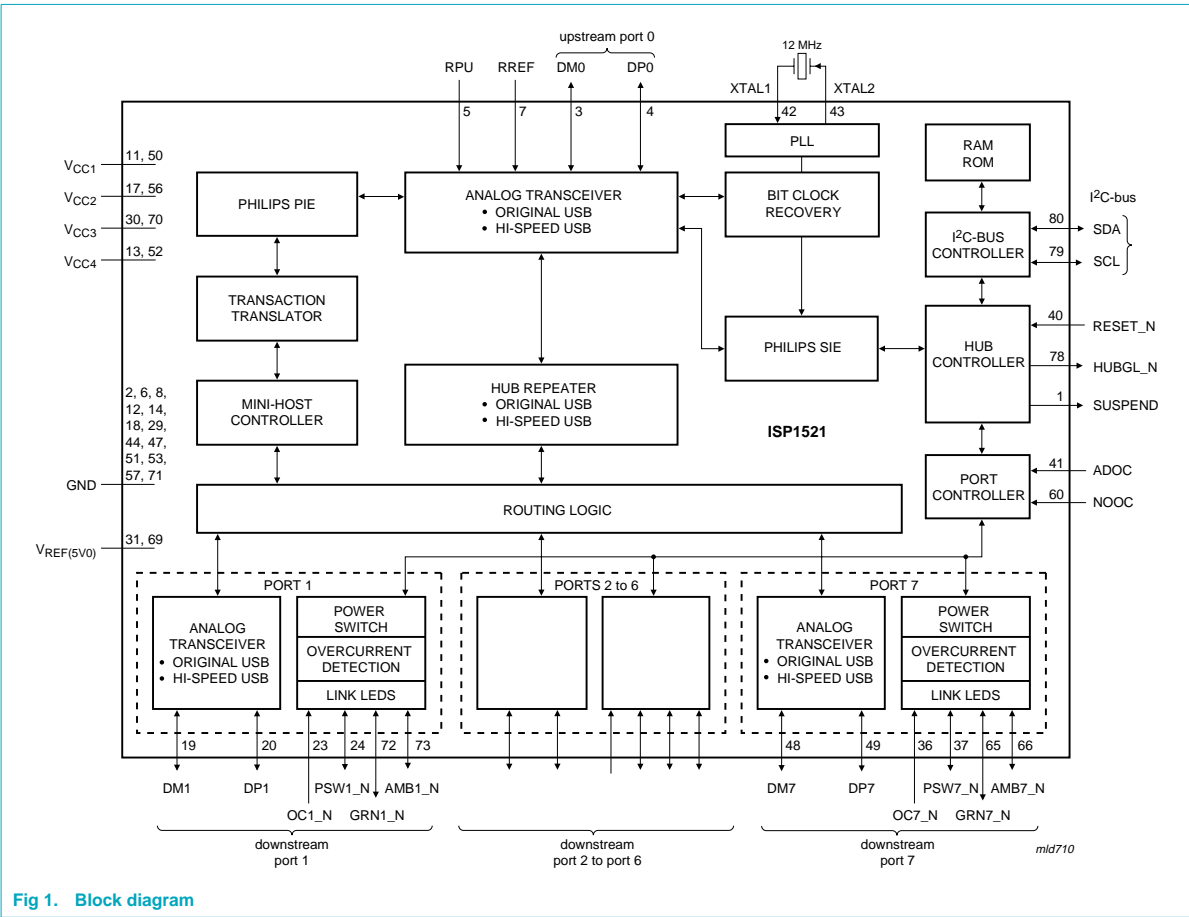
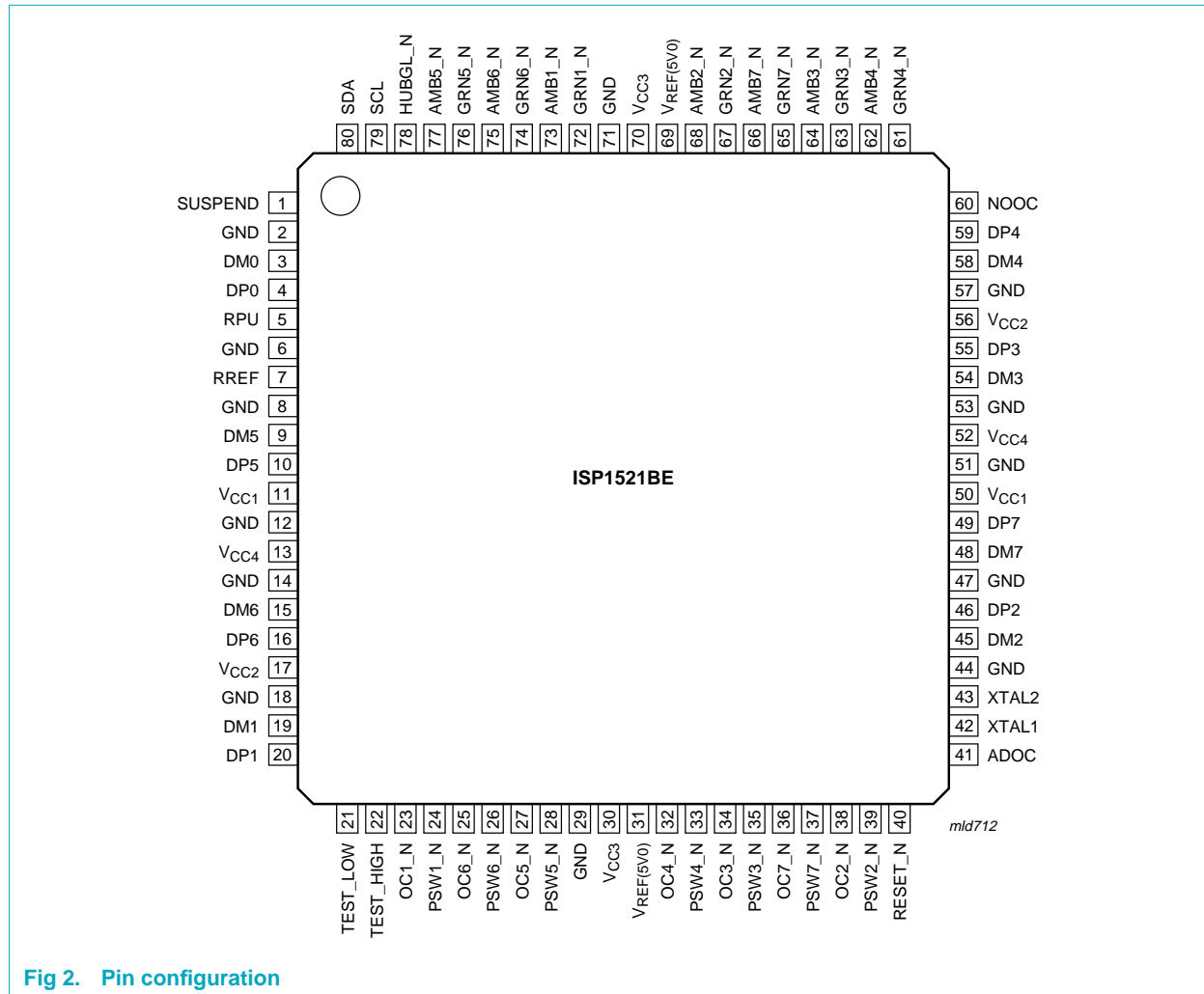

Fig 1. Block diagram

## 6. Pinning information

### 6.1 Pinning



### 6.2 Pin description

**Table 2. Pin description**

Symbol <sup>[1]</sup>	Pin	Type	Description <sup>[2]</sup>
SUSPEND	1	I/O	connect to ground through a 100 kΩ resistor
GND	2	-	ground supply
DM0	3	AI/O	upstream facing port 0 D- connection (analog)
DP0	4	AI/O	upstream facing port 0 D+ connection (analog)
RPU	5	AI	pull-up resistor connection; connect this pin through a resistor of 1.5 kΩ ± 5 % to 3.3 V
GND	6	-	ground supply

Table 2. Pin description ...continued

Symbol <sup>[1]</sup>	Pin	Type	Description <sup>[2]</sup>
RREF	7	AI	reference resistor connection; connect this pin through a resistor of $12\text{ k}\Omega \pm 1\%$ to an analog band gap ground reference
GND	8	-	ground supply
DM5	9	AI/O	downstream facing port 5 D- connection (analog) <sup>[3]</sup>
DP5	10	AI/O	downstream facing port 5 D+ connection (analog) <sup>[3]</sup>
V <sub>CC1</sub>	11	-	supply voltage 1 (3.3 V) (analog)
GND	12	-	ground supply
V <sub>CC4</sub>	13	-	supply voltage 4 (3.3 V) (crystal and PLL)
GND	14	-	ground supply
DM6	15	AI/O	downstream facing port 6 D- connection (analog) <sup>[3]</sup>
DP6	16	AI/O	downstream facing port 6 D+ connection (analog) <sup>[3]</sup>
V <sub>CC2</sub>	17	-	supply voltage 2 (3.3 V) (transceiver)
GND	18	-	ground supply
DM1	19	AI/O	downstream facing port 1 D- connection (analog) <sup>[4]</sup>
DP1	20	AI/O	downstream facing port 1 D+ connection (analog) <sup>[4]</sup>
TEST_LOW	21	-	connect to GND
TEST_HIGH	22	-	connect to 5.0 V through a 10 k $\Omega$ resistor
OC1_N	23	AI/I	overcurrent sense input for downstream facing port 1 (analog/digital)
PSW1_N	24	I/O	<b>output</b> — power switch control output (open-drain) with an internal pull-up resistor for downstream facing port 1 <b>input</b> — function of the pin when used as an input is given in <a href="#">Table 5</a>
OC6_N	25	AI/I	overcurrent sense input for downstream facing port 6 (analog/digital)
PSW6_N	26	I/O	<b>output</b> — power switch control output (open-drain) with an internal pull-up resistor for downstream facing port 6 <b>input</b> — function of the pin when used as an input is given in <a href="#">Table 5</a>
OC5_N	27	AI/I	overcurrent sense input for downstream facing port 5 (analog/digital)
PSW5_N	28	I/O	<b>output</b> — power switch control output (open-drain) with an internal pull-up resistor for downstream facing port 5 <b>input</b> — function of the pin when used as an input is given in <a href="#">Table 5</a>
GND	29	-	ground supply
V <sub>CC3</sub>	30	-	supply voltage 3 (3.3 V) (digital)
V <sub>REF(5V0)</sub>	31	-	reference voltage ( $5\text{ V} \pm 5\%$ ); used to power internal pull-up resistors of PSWn_N pins and also for the analog overcurrent detection
OC4_N	32	AI/I	overcurrent sense input for downstream facing port 4 (analog/digital)

Table 2. Pin description ...continued

Symbol <sup>[1]</sup>	Pin	Type	Description <sup>[2]</sup>
PSW4_N	33	I/O	<b>output</b> — power switch control output (open-drain) with an internal pull-up resistor for downstream facing port 4 <b>input</b> — function of the pin when used as an input is given in <a href="#">Table 5</a>
OC3_N	34	AI/I	overcurrent sense input for downstream facing port 3 (analog/digital)
PSW3_N	35	I/O	<b>output</b> — power switch control output (open-drain) with an internal pull-up resistor for downstream facing port 3 <b>input</b> — function of the pin when used as an input is given in <a href="#">Table 5</a>
OC7_N	36	AI/I	overcurrent sense input for downstream facing port 7 (analog/digital)
PSW7_N	37	I/O	<b>output</b> — power switch control output (open-drain) with an internal pull-up resistor for downstream facing port 7 <b>input</b> — function of the pin when used as an input is given in <a href="#">Table 5</a>
OC2_N	38	AI/I	overcurrent sense input for downstream facing port 2 (analog/digital)
PSW2_N	39	I/O	<b>output</b> — power switch control output (open-drain) with an internal pull-up resistor for downstream facing port 2 <b>input</b> — function of the pin when used as an input is given in <a href="#">Table 5</a>
RESET_N	40	I	asynchronous reset input; when reset is active, the internal switch to the 1.5 k $\Omega$ external resistor is opened, and all pins DPn and DMn are 3-state; it is recommended that you connect to any one of the 3.3 V V <sub>CC</sub> pins through an RC circuit; refer to the schematics in <i>ISP1521 Hub Demo Board User's Guide</i>
ADOC	41	I	analog or digital overcurrent detect selection input; LOW selects digital mode and HIGH (3.3 V or 5.0 V) selects analog mode
XTAL1	42	I	crystal oscillator input (12 MHz)
XTAL2	43	O	crystal oscillator output (12 MHz)
GND	44	-	ground supply
DM2	45	AI/O	downstream facing port 2 D <sup>-</sup> connection (analog) <sup>[4]</sup>
DP2	46	AI/O	downstream facing port 2 D <sup>+</sup> connection (analog) <sup>[4]</sup>
GND	47	-	ground supply
DM7	48	AI/O	downstream facing port 7 D <sup>-</sup> connection (analog) <sup>[3]</sup>
DP7	49	AI/O	downstream facing port 7 D <sup>+</sup> connection (analog) <sup>[3]</sup>
V <sub>CC1</sub>	50	-	supply voltage 1 (3.3 V) (analog)
GND	51	-	ground supply
V <sub>CC4</sub>	52	-	supply voltage 4 (3.3 V) (crystal and PLL)
GND	53	-	ground supply
DM3	54	AI/O	downstream facing port 3 D <sup>-</sup> connection (analog) <sup>[3]</sup>
DP3	55	AI/O	downstream facing port 3 D <sup>+</sup> connection (analog) <sup>[3]</sup>
V <sub>CC2</sub>	56	-	supply voltage 2 (3.3 V) (transceiver)
GND	57	-	ground supply

Table 2. Pin description ...continued

Symbol <sup>[1]</sup>	Pin	Type	Description <sup>[2]</sup>
DM4	58	AI/O	downstream facing port 4 D- connection (analog) <sup>[3]</sup>
DP4	59	AI/O	downstream facing port 4 D+ connection (analog) <sup>[3]</sup>
NOOC	60	I	no overcurrent protection selection input; connect this pin to HIGH (3.3 V) to select no overcurrent protection; if no overcurrent is selected, all OC_N pins must be connected to V <sub>REF(5V0)</sub>
GRN4_N	61	I/O	<b>output</b> — green LED port indicator (open-drain) for downstream facing port 4 <b>input</b> — function of the pin when used as an input is given in <a href="#">Table 9</a>
AMB4_N	62	I/O	<b>output</b> — amber LED port indicator (open-drain) for downstream facing port 4 <b>input</b> — function of the pin when used as an input is given in <a href="#">Table 8</a>
GRN3_N	63	I/O	<b>output</b> — green LED port indicator (open-drain) for downstream facing port 3 <b>input</b> — function of the pin when used as an input is given in <a href="#">Table 9</a>
AMB3_N	64	I/O	<b>output</b> — amber LED port indicator (open-drain) for downstream facing port 3 <b>input</b> — function of the pin when used as an input is given in <a href="#">Table 8</a>
GRN7_N	65	I/O	<b>output</b> — green LED port indicator (open-drain) for downstream facing port 7 <b>input</b> — function of the pin when used as an input is given in <a href="#">Table 9</a>
AMB7_N	66	I/O	<b>output</b> — amber LED port indicator (open-drain) for downstream facing port 7 <b>input</b> — function of the pin when used as an input is given in <a href="#">Table 8</a>
GRN2_N	67	I/O	<b>output</b> — green LED port indicator (open-drain) for downstream facing port 2 <b>input</b> — function of the pin when used as an input is given in <a href="#">Table 9</a>
AMB2_N	68	I/O	<b>output</b> — amber LED port indicator (open-drain) for downstream facing port 2 <b>input</b> — function of the pin when used as an input is given in <a href="#">Table 8</a>
V <sub>REF(5V0)</sub>	69	-	reference voltage (5 V ± 5 %); used to power internal pull-up resistors of PSWn_N pins and also for the analog overcurrent detection
V <sub>CC3</sub>	70	-	supply voltage 3 (3.3 V) (digital)
GND	71	-	ground supply
GRN1_N	72	I/O	<b>output</b> — green LED port indicator (open-drain) for downstream facing port 1 <b>input</b> — function of the pin when used as an input is given in <a href="#">Table 9</a>



Table 2. Pin description ...continued

Symbol <sup>[1]</sup>	Pin	Type	Description <sup>[2]</sup>
AMB1_N	73	I/O	<b>output</b> — amber LED port indicator (open-drain) for downstream facing port 1 <b>input</b> — function of the pin when used as an input is given in <a href="#">Table 8</a>
GRN6_N	74	I/O	<b>output</b> — green LED port indicator (open-drain) for downstream facing port 6 <b>input</b> — function of the pin when used as an input is given in <a href="#">Table 9</a>
AMB6_N	75	I/O	<b>output</b> — amber LED port indicator (open-drain) for downstream facing port 6 <b>input</b> — function of the pin when used as an input is given in <a href="#">Table 8</a>
GRN5_N	76	I/O	<b>output</b> — green LED port indicator (open-drain) for downstream facing port 5 <b>input</b> — function of the pin when used as an input is given in <a href="#">Table 9</a>
AMB5_N	77	I/O	<b>output</b> — amber LED port indicator (open-drain) for downstream facing port 5 <b>input</b> — function of the pin when used as an input is given in <a href="#">Table 8</a>
HUBGL_N	78	O	hub GoodLink LED indicator output; the LED is off until the hub is configured; a transaction between the host and the hub will blink the LED off for 100 ms; this LED is off in suspend mode (open-drain)
SCL	79	I/O	I <sup>2</sup> C-bus clock (open-drain); see <a href="#">Table 11</a>
SDA	80	I/O	I <sup>2</sup> C-bus data (open-drain); see <a href="#">Table 11</a>

[1] Symbol names ending with underscore N (for example, NAME\_N) represent active LOW signals.

[2] The maximum current the ISP1521 can sink on a pin is 8 mA.

[3] To disable a downstream port n, connect both pins DPn and DMn to V<sub>CC</sub> (3.3 V); unused ports must be disabled in reverse order starting from port 7.

[4] Downstream ports 1 and 2 cannot be disabled.

## 7. Functional description

### 7.1 Analog transceivers

The integrated transceivers directly interface to USB lines. They can transmit and receive serial data at high-speed (480 Mbit/s), full-speed (12 Mbit/s) and low-speed (1.5 Mbit/s).

### 7.2 Hub controller core

The main components of the hub core are:

- Philips Serial Interface Engine (SIE)
- Routing logic
- Transaction Translator (TT)
- Mini-Host Controller
- Hub repeater
- Hub controller
- Port controller
- Bit clock recovery.

#### 7.2.1 Philips serial interface engine

The Philips Serial Interface Engine (SIE) implements the full USB protocol layer. It is completely hardwired for speed and needs no firmware intervention. The functions of this block include: synchronization, pattern recognition, parallel or serial conversion, bit (de-)stuffing, CRC checking and generation, Packet Identifier (PID) verification and generation, address recognition, and handshake evaluation and generation.

#### 7.2.2 Routing logic

The routing logic directs signaling to appropriate modules (mini-Host Controller, Original USB repeater and Hi-Speed USB repeater) according to the topology in which the hub is placed.

#### 7.2.3 Transaction translator

The Transaction Translator (TT) acts as a go-between mechanism that links devices operating in Original USB mode and Hi-Speed USB upstream mode. For the 'IN' direction, data is concatenated in TT buffers till the proper length is reached, before the host takes the transaction. In the reverse direction (OUT), the mini-host dispenses the data contained in TT buffers over a period that fits into the Original USB bandwidth. This continues until all outgoing data is emptied. TT buffers are used only on split transactions.

#### 7.2.4 Mini-Host Controller

The internal mini-host generates all the Original USB IN, OUT or SETUP tokens for the downstream facing ports, while the upstream facing port is in high-speed mode. The responses from the Original USB devices are collected in TT buffers, until the end of the complete split transaction clears TT buffers.

### 7.2.5 Hub repeater

A hub repeater manages connectivity on a per packet basis. It implements packet signaling connectivity and resume connectivity. There are two repeaters in the ISP1521: a Hi-Speed USB repeater and an Original USB repeater. The only major difference between these two repeaters is the speed at which they operate. When the hub is connected to an Original USB system, it automatically switches itself to function as an Original USB hub.

### 7.2.6 Hub and port controllers

The hub controller provides status report. The port controller provides control for individual downstream facing ports; it controls the port routing module. Any port status change will be reported to the host using the hub status change (interrupt) endpoint.

### 7.2.7 Bit clock recovery

The bit clock recovery circuit extracts the clock from the incoming USB data stream.

## 7.3 Phase-locked loop clock multiplier

A 12 MHz-to-480 MHz clock multiplier Phase-Locked Loop (PLL) is integrated on-chip. This allows the use of low-cost 12 MHz crystals. The low crystal frequency also minimizes EMI. No external components are required for the operation of the PLL.

## 7.4 I<sup>2</sup>C-bus controller

A simple serial I<sup>2</sup>C-bus interface is provided to transfer vendor ID, product ID and string descriptor from an external I<sup>2</sup>C-bus EEPROM or microcontroller. A master/slave I<sup>2</sup>C-bus protocol is implemented according to the timing requirements as mentioned in I<sup>2</sup>C-bus standard specifications. The maximum data count during I<sup>2</sup>C-bus transfers for the ISP1521 is 256 B.

## 7.5 Overcurrent detection circuit

An overcurrent detection circuit is integrated on-chip. The main features of this circuit are: self reporting, automatic resetting, low-trip time and low cost. This circuit offers an easy solution at no extra hardware cost on the board.

## 7.6 GoodLink

Indication of a good USB connection is provided through the GoodLink technology. An LED can be directly connected to pin HUBGL\_N through an external 330  $\Omega$  resistor.

During enumeration, the LED momentarily blinks on. After successful configuration, the LED blinks off for 100 ms upon each transaction.

This feature provides a user-friendly indication of the status of the hub, the connected downstream devices, and the USB traffic. It is a useful diagnostics tool to isolate faulty USB equipment, and helps to reduce field support and hotline costs.

## 7.7 Power-on reset

The ISP1521 has an internal Power-On Reset (POR) circuit.

The triggering voltage of the POR circuit is 2.03 V nominal. A POR is automatically generated when  $V_{CC}$  goes below the trigger voltage for a duration longer than 1  $\mu\text{s}$ .

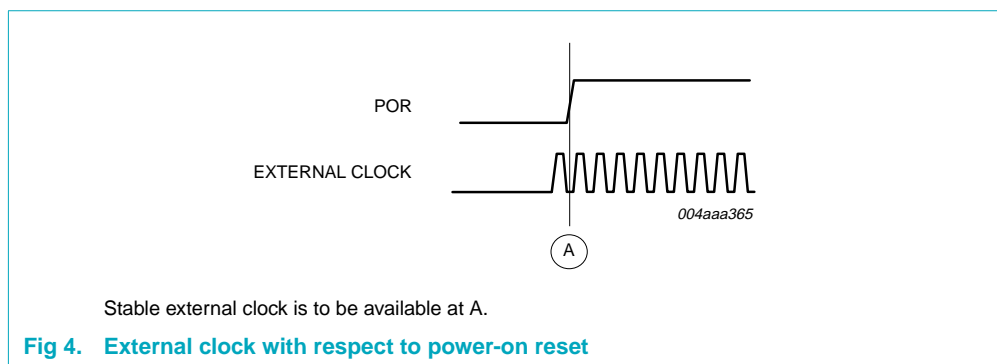
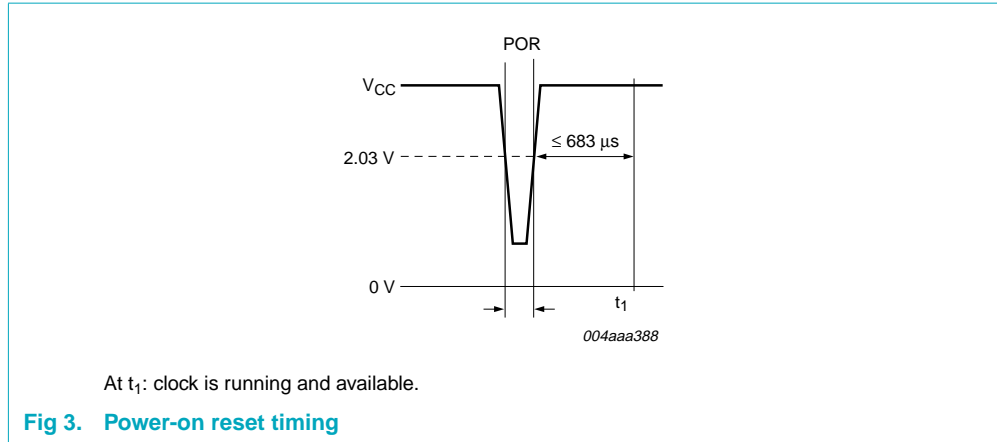

## 8. Configuration selections

The ISP1521 is configured through I/O pins and, optionally, through an external I<sup>2</sup>C-bus, in which case the hub can update its configuration descriptors as a master or as a slave.

[Table 3](#) shows configuration parameters.

**Table 3. Configuration parameters**

Mode and selection	Option	Configuration method			
		Pin control		Software control	
		Control pin	Reference	Affected field	Reference
Number of downstream facing ports	2 ports	DM1/DP1 to DM7/DP7	see <a href="#">Section 8.1.1</a>	bNbrPorts0	see <a href="#">Table 22</a>
	3 ports				
	4 ports				
	5 ports				
	6 ports				
	7 ports				
Power switching mode	none	PSW1_N to PSW7_N	see <a href="#">Section 8.1.2</a>	wHubCharacteristics: bits D1 and D0 bPwrOn2PwrGood: time interval	see <a href="#">Table 22</a>
	ganged				
	multiple ganged <sup>[1]</sup>				
	individual				
Overcurrent protection mode	none	NOOC and OC1_N to OC7_N	see <a href="#">Section 8.1.3</a>	wHubCharacteristics: bits D4 and D3	see <a href="#">Table 22</a>
	global <sup>[2]</sup>				
	multiple ganged				
	individual				
Nonremovable ports	any port can be nonremovable	AMBn_N	see <a href="#">Section 8.1.4</a>	wHubCharacteristics: bit D2 (compound hub) DeviceRemovable: bit map	see <a href="#">Table 22</a>
Port indicator support	no	all GRNn_N	see <a href="#">Section 8.1.5</a>	wHubCharacteristics: bit D7	see <a href="#">Table 22</a>
	yes				

[1] Multiple ganged power mode is reported as individual power mode; refer to *Universal Serial Bus Specification Rev. 2.0*.

[2] When the hub uses global overcurrent protection mode, the overcurrent indication is through wHubStatus field bit 1 (overcurrent) and the corresponding change bit (overcurrent change).

## 8.1 Configuration through I/O pins

### 8.1.1 Number of downstream facing ports

To discount a physical downstream facing port, connect pins DP and DM of that downstream facing port to  $V_{CC}$  (3.3 V) starting from the highest port number (7); see [Table 4](#).

The sum of physical ports configured is reflected in the bNbrPorts field.

**Table 4. Downstream facing port number pin configuration**

Number of physical downstream facing port	DM1/DP1	DM2/DP2	DM3/DP3	DM4/DP4	DM5/DP5	DM6/DP6	DM7/DP7
7	15 k $\Omega$ pull-down	15 k $\Omega$ pull-down	15 k $\Omega$ pull-down	15 k $\Omega$ pull-down	15 k $\Omega$ pull-down	15 k $\Omega$ pull-down	15 k $\Omega$ pull-down
6	15 k $\Omega$ pull-down	15 k $\Omega$ pull-down	15 k $\Omega$ pull-down	15 k $\Omega$ pull-down	15 k $\Omega$ pull-down	15 k $\Omega$ pull-down	$V_{CC}$
5	15 k $\Omega$ pull-down	15 k $\Omega$ pull-down	15 k $\Omega$ pull-down	15 k $\Omega$ pull-down	15 k $\Omega$ pull-down	$V_{CC}$	$V_{CC}$
4	15 k $\Omega$ pull-down	15 k $\Omega$ pull-down	15 k $\Omega$ pull-down	15 k $\Omega$ pull-down	$V_{CC}$	$V_{CC}$	$V_{CC}$
3	15 k $\Omega$ pull-down	15 k $\Omega$ pull-down	15 k $\Omega$ pull-down	$V_{CC}$	$V_{CC}$	$V_{CC}$	$V_{CC}$
2	15 k $\Omega$ pull-down	15 k $\Omega$ pull-down	$V_{CC}$	$V_{CC}$	$V_{CC}$	$V_{CC}$	$V_{CC}$

### 8.1.2 Power switching

Power switching of downstream ports can be done **individually** or **ganged**, where all ports are simultaneously switched with one power switch. The ISP1521 supports both modes, which can be selected using input PSWn\_N; see [Table 5](#).

#### 8.1.2.1 Voltage drop requirements

Self-powered hubs are required to provide a minimum of 4.75 V to its output port connectors at all legal load conditions. To comply with Underwriters Laboratory Inc. (UL) safety requirements, the power from any port must be limited to 25 W (5 A at 5 V). Overcurrent protection may be implemented on a global or individual basis.

Assuming a 5 V  $\pm$  3 % power supply, the worst-case supply voltage is 4.85 V. This only allows a voltage drop of 100 mV across the hub Printed-Circuit Board (PCB) to each downstream connector. This includes a voltage drop across the:

- Power supply connector
- Hub PCB (power and ground traces, ferrite beads)
- Power switch (FET on-resistance)
- Overcurrent sense device

The PCB resistance and power supply connector resistance may cause a drop of 25 mV, leaving only 75 mV as the voltage drop allowed across the power switch and overcurrent sense device. Individual voltage drop components are shown in [Figure 5](#).

For global overcurrent detection, an increased voltage drop is needed for the overcurrent sense device (in this case, a low-ohmic resistor). This can be realized by using a special power supply of 5.1 V ± 3 %, as shown in [Figure 6](#).

The PCB resistance may cause a drop of 25 mV, which leaves 75 mV for the power switch and overcurrent sense device.

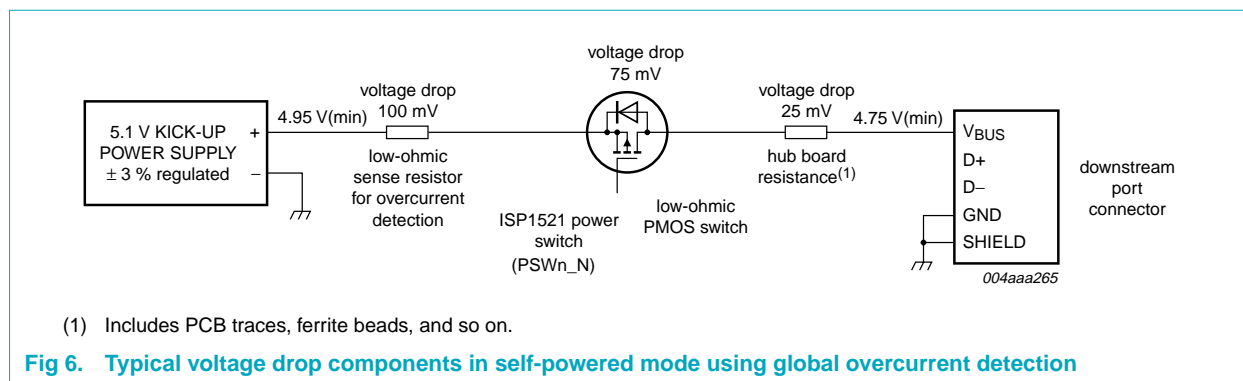
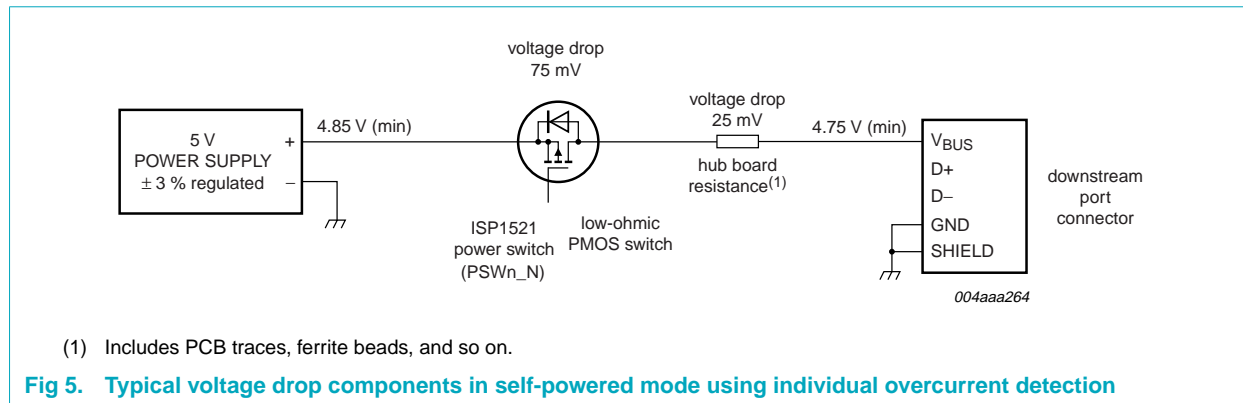

PSWn\_N pins have integrated weak pull-up resistors inside the chip.

**Table 5. Power switching mode: pin configuration**

Power switching mode	PSW1_N	PSW2_N	PSW3_N	PSW4_N	PSW5_N	PSW6_N	PSW7_N
None	ground	ground	ground	ground	ground	ground	ground
Ganged	internal pull-up	ground	ground	ground	ground	ground	ground
Individual	internal pull-up	internal pull-up	internal pull-up	internal pull-up	internal pull-up	internal pull-up	internal pull-up

### 8.1.3 Overcurrent protection mode

The ISP1521 supports all overcurrent protection modes: none, global and individual.

No overcurrent protection mode reporting is selected when pin NOOC = HIGH. Global and individual overcurrent protection modes are selected using pins PSWn\_N, following power switching modes selection scheme; see [Table 6](#).

For global overcurrent protection mode, only PSW1\_N and OC1\_N are active; that is, in this mode, the remaining overcurrent indicator pins are disabled. To inhibit the analog overcurrent detection, OC\_N pins must be connected to  $V_{REF(5V0)}$ .

**Table 6. Overcurrent protection mode pin configuration**

Power switching mode	NOOC	PSW1_N	PSW2_N	PSW3_N	PSW4_N	PSW5_N	PSW6_N	PSW7_N
None	HIGH	ground	ground	ground	ground	ground	ground	ground
Global	LOW	internal pull-up	ground	ground	ground	ground	ground	ground
Individual	LOW	internal pull-up	internal pull-up	internal pull-up	internal pull-up	internal pull-up	internal pull-up	internal pull-up

Both analog and digital overcurrent modes are supported; see [Table 7](#).

For digital overcurrent detection, the normal digital TTL level is accepted on overcurrent input pins. For analog overcurrent detection, the threshold is given in [Section 14](#). In this mode, to filter out false overcurrent conditions because of inrush and spikes, a dead time of 15 ms is built into the IC, that is, overcurrent must persist for 15 ms before it is reported to the host.

**Table 7. Overcurrent detection mode selection pin configuration**

Pin ADOC	Mode selection	Description
3.3 V or 5.0 V	analog	threshold $\Delta V_{trip}$
Ground	digital	normal digital TTL level

#### 8.1.4 Nonremovable port

A nonremovable port, by definition, is a port that is embedded inside the hub application box and is not externally accessible. The LED port indicators (pins AMBn\_N) of such a port are not used. Therefore, the corresponding amber LED port indicators are disabled to signify that the port is nonremovable; see [Table 8](#).

More than one nonremovable port can be specified by appropriately connecting the corresponding amber LED indicators. At least one port should, however, be left as a removable port.

The detection of any nonremovable port sets the hub descriptor to a compound hub.

**Table 8. Nonremovable port pin configuration**

AMBn_N (n = 1 to 7)	Nonremovable port
Ground	nonremovable
Pull-up with amber LED	removable

#### 8.1.5 Port indicator support

The port indicator support can be disabled by grounding all green port indicators (all pins GRNn\_N); see [Table 9](#). This is a global feature. You cannot disable port indicators for only one port.



Table 9. Port indicator support: pin configuration

GRN1_N to GRN7_N	Port indicator support
Ground	not supported
LED pull-up green LED for at least one port	supported

## 8.2 Device descriptors and string descriptors settings using I<sup>2</sup>C-bus

### 8.2.1 Background information on I<sup>2</sup>C-bus

The I<sup>2</sup>C-bus is suitable for bidirectional communication between ICs or modules. It consists of two bidirectional lines: SDA for data signals, and SCL for clock signals. Both these lines must be connected to a positive supply voltage through a pull-up resistor.

The basic I<sup>2</sup>C-bus protocol is defined as:

- Data transfer is initiated only when the bus is not busy.
- Changes in the data line occur when the clock is LOW, and must be stable when the clock is HIGH. Any changes in data lines when the clock is HIGH will be interpreted as control signals.

#### 8.2.1.1 Different conditions on I<sup>2</sup>C-bus

The I<sup>2</sup>C-bus protocol defines the following conditions:

**Not busy** — both SDA and SCL remain HIGH.

**START** — a HIGH-to-LOW transition on SDA, while SCL is HIGH.

**STOP** — a LOW-to-HIGH transition on SDA, while SCL is HIGH.

**Data valid** — after a START condition, data on SDA must be stable for the duration of the HIGH period of SCL.

#### 8.2.1.2 Data transfer

The master initiates each data transfer using a START condition and terminates it by generating a STOP condition. To facilitate the next byte transfer, each byte of data must be acknowledged by the receiver. The acknowledgment is done by pulling the SDA line LOW on the ninth bit of the data. An extra clock pulse must be generated by the master to accommodate this bit.

For details on the operation of the bus, refer to *The I<sup>2</sup>C-bus specification*.

#### 8.2.1.3 I<sup>2</sup>C-bus address

The address of the ISP1521 is given in [Table 10](#).

Table 10. I<sup>2</sup>C-bus slave address

Bit	Slave address							LSB	Write
	A7	A6	A5	A4	A3	A2	A1		
Value	0	0	1	1	0	1	0	0	

8.2.2 Architecture of configurable hub descriptors

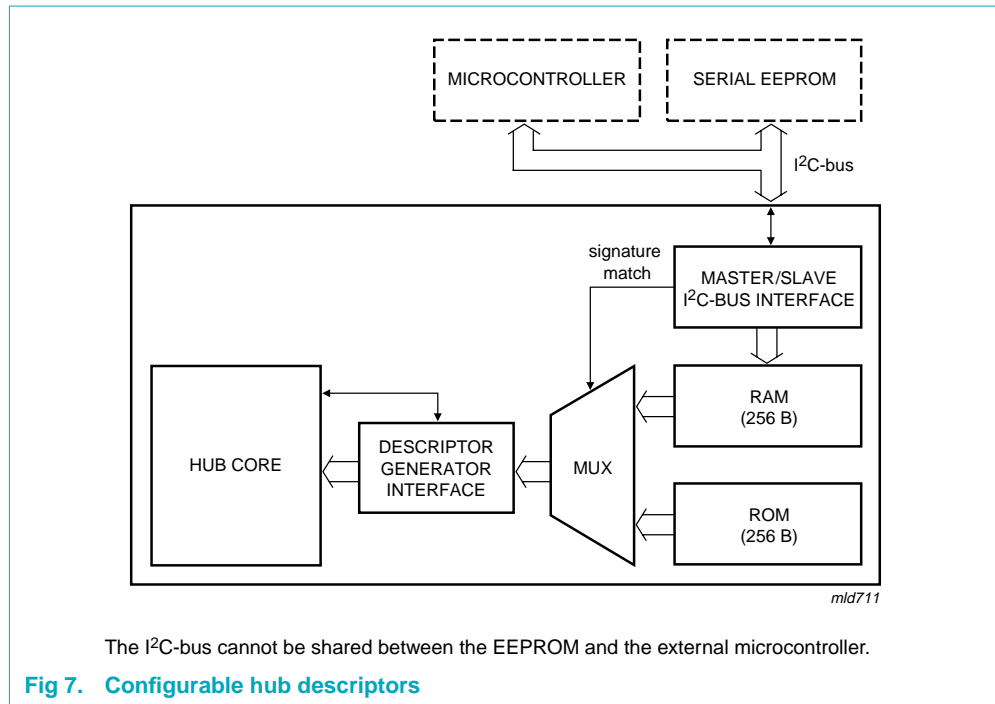

The configurable hub descriptors can be masked in the internal ROM memory; see [Figure 7](#). These descriptors can also be supplied from an external EEPROM or a microcontroller. The ISP1521 implements both the master and slave I<sup>2</sup>C-bus controllers. The information from the external EEPROM or the microcontroller is transferred into the internal RAM during the power-on reset. A signature word is used to identify correct descriptors. If the signature matches, the content of the RAM is chosen instead of the ROM.

When external microcontroller mode is selected and while the external microcontroller is writing to the internal RAM, any request to configurable descriptors will be responded to with a Not Acknowledge (NAK). There is no specified time-out period for the NAK signal. This data is then passed to the host during the enumeration process.

The three configuration methods are selected by connecting pins SCL and SDA in the manner given in [Table 11](#).

**Table 11. Configuration method**

Configuration method	SCL	SDA
Internal ROM	ground	ground
External EEPROM	2.2 kΩ-to-4.7 kΩ pull-up	2.2 kΩ-to-4.7 kΩ pull-up
External microcontroller	driven LOW by the microcontroller during reset	2.2 kΩ-to-4.7 kΩ pull-up

### 8.2.3 ROM or EEPROM map

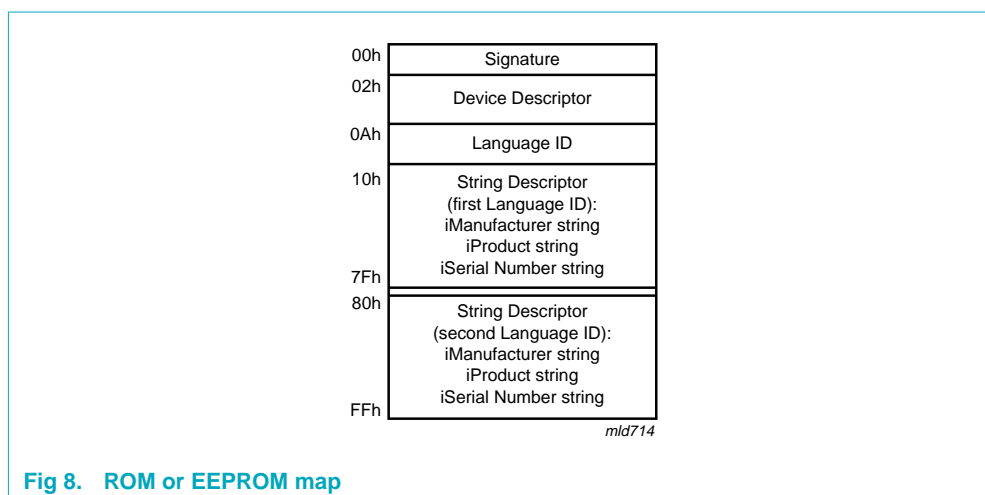

Fig 8. ROM or EEPROM map

**Remark:** A 128 B EEPROM supports one language ID only, and a 256 B EEPROM supports two language IDs.

### 8.2.4 ROM or EEPROM detailed map

Table 12. ROM or EEPROM detailed map

Address (hex)	Content	Default (hex)	Example (hex)	Comment
<b>Signature descriptor</b>				
00	signature (low)	55	-	signature to signify valid data comment
01	signature (high)	AA	-	
<b>Device descriptor</b>				
02	idVendor (low)	CC	-	Philips Semiconductors vendor ID
03	idVendor (high)	04	-	
04	idProduct (low)	21	-	ISP1521 product ID
05	idProduct (high)	15	-	
06	bcdDevice (low)	00	-	device release; silicon revision increments this value
07	bcdDevice (high)	02	-	
08	RSV, iSN, iP, iM	-	00	if all the three strings are supported, the value of this byte is 39h
09	reserved	-	FF	-
<b>String descriptor index 0 (language ID)</b>				
0A	bLength <sup>[1]</sup>	-	06	two language ID support
0B	bDescriptorType	-	03 <sup>[2]</sup>	STRING
0C	wLANGID[0]	-	09	LANGID code zero (first language ID) (English USA in this example)
0D		-	04	
0E	wLANGID[1]	-	09	LANGID code one (second language ID) (English UK in this example)
0F		-	08	

Table 12. ROM or EEPROM detailed map ...continued

Address (hex)	Content	Default (hex)	Example (hex)	Comment
<b>String descriptor Index 1 (iManufacturer)</b> <sup>[3]</sup>				
10	bLength	-	2E	string descriptor length (manufacturer ID)
11	bDescriptorType	-	03 <sup>[2]</sup>	STRING
12 13	bString	-	50 00	P of Philips
14 15		-	68 00	h
16 17		-	69 00	i
18 19		-	6C 00	l
1A 1B		-	69 00	i
1C 1D		-	70 00	p
1E 1F		-	73 00	s
20 21		-	20 00	
22 23		-	53 00	S of Semiconductors
24 25		-	65 00	e
26 27		-	6D 00	m
28 29		-	69 00	i
2A 2B		-	63 00	c
2C 2D		-	6F 00	o
2E 2F		-	6E 00	n
30 31		-	64 00	d
32 33		-	75 00	u
34 35		-	63 00	c
36 37		-	74 00	t
38 39		-	6F 00	o
3A 3B		-	72 00	r
3C 3D		-	73 00	s
<b>String descriptor Index 2 (iProduct)</b>				
3E	bLength	-	10	string descriptor length (product ID)
3F	bDescriptorType	-	03 <sup>[2]</sup>	STRING
40 41	bString	-	49 00	I of ISP1521
42 43		-	53 00	S
44 45		-	50 00	P
46 47		-	31 00	1
48 49		-	35 00	5
4A 4B		-	32 00	2
4C 4D		-	31 00	1
<b>String descriptor Index 3 (iSerialNumber)</b>				
<b>Remark: If supported, this string must be unique.</b>				
4E	bLength	-	3A	string descriptor length (serial number)
4F	bDescriptorType	-	03 <sup>[2]</sup>	STRING
50 51	bString	-	39 00	9 of 947337877678 = wired support

Table 12. ROM or EEPROM detailed map ...continued

Address (hex)	Content	Default (hex)	Example (hex)	Comment
52 53		-	34 00	4
54 55		-	37 00	7
56 57		-	33 00	3
58 59		-	33 00	3
5A 5B		-	37 00	7
5C 5D		-	38 00	8
5E 5F		-	37 00	7
60 61		-	37 00	7
62 63		-	36 00	6
64 65		-	37 00	7
66 67		-	38 00	8
68 69		-	20 00	
6A 6B		-	3D 00	=
6C 6D		-	20 00	
6E 6F		-	77 00	w
70 71		-	69 00	i
72 73		-	72 00	r
74 75		-	65 00	e
76 77		-	64 00	d
78 79		-	20 00	
7A 7B		-	73 00	s
7C 7D		-	75 00	u
7E 7F		-	70 00	p
80 81		-	70 00	p
82 83		-	6F 00	o
84 85		-	72 00	r
86 87		-	74 00	t
<b>String descriptor Index 1 (iManufacturer) second language</b>				
88	bLength	-	2E	string descriptor length (manufacturer ID)
89	bDescriptorType	-	03 <sup>[2]</sup>	STRING
8A 8B	bString	-	50 00	P of Philips
8C 8D		-	68 00	h
8E 8F		-	69 00	i
90 91		-	6C 00	l
92 93		-	69 00	i
94 95		-	70 00	p
96 97		-	73 00	s
98 99		-	20 00	
9A 9B		-	53 00	S of Semiconductors
9C 9D		-	65 00	e

Table 12. ROM or EEPROM detailed map ...continued

Address (hex)	Content	Default (hex)	Example (hex)	Comment
9E 9F		-	6D 00	m
A0 A1		-	69 00	i
A2 A3		-	63 00	c
A4 A5		-	6F 00	o
A6 A7		-	6E 00	n
A8 A9		-	64 00	d
AA AB		-	75 00	u
AC AD		-	63 00	c
AE AF		-	74 00	t
B0 B1		-	6F 00	o
B2 B3		-	72 00	r
B4 B5		-	73 00	s
<b>String descriptor Index 2 (iProduct)</b>				
B6	bLength	-	10 <sup>[1]</sup>	string descriptors (product ID)
B7	bDescriptorType	-	03 <sup>[2]</sup>	STRING
B8 B9	bString	-	49 00	I of ISP1521
BA BB		-	53 00	S
BC BD		-	50 00	P
BE BF		-	31 00	1
C0 C1		-	35 00	5
C2 C3		-	32 00	2
C4 C5		-	31 00	1
<b>String descriptor Index 3 (iSerialNumber)</b>				
C6	bLength	-	16 <sup>[1]</sup>	string descriptors (serial number)
C7	bDescriptorType	-	03 <sup>[2]</sup>	STRING
C8 C9	bString	-	36 00	6 of 6568824022
CA CB		-	35 00	5
CC CD		-	36 00	6
CE CF		-	38 00	8
D0 D1		-	38 00	8
D2 D3		-	32 00	2
D4 D5		-	34 00	4
D6 D7		-	30 00	0
D8 D9		-	32 00	2
DA DB		-	32 00	2
DC DD		-	FF FF	
DE DF		-	FF FF	
E0 E1		-	FF FF	
E2 E3		-	FF FF	
E4 E5		-	FF FF	

Table 12. ROM or EEPROM detailed map ...continued

Address (hex)	Content	Default (hex)	Example (hex)	Comment
E6 E7		-	FF FF	
E8 E9		-	FF FF	
EA EB		-	FF FF	
EC ED		-	FF FF	
EE EF		-	FF FF	
F0 F1		-	FF FF	
F2 F3		-	FF FF	
F4 F5		-	FF FF	
F6 F7		-	FF FF	
F8 F9		-	FF FF	
FA FB		-	FF FF	
FC FD		-	FF FF	
FE		-	FF	
FF		-	FF	upper boundary of all string descriptors

- [1] If this string descriptor is not supported, this bLength field must be programmed with value 02h.
- [2] If this string descriptor is not supported, this bDescriptorType field must be used (programmed with any value, for example, 03h).
- [3] String descriptor index (iManufacturer) starts from address 0Eh for one language ID support and 10h for two languages ID support.

## 9. Hub controller description

Each USB device is composed of several independent logic endpoints. An endpoint acts as a terminus of communication flow between the host and the device. At design time, each endpoint is assigned a unique number (endpoint identifier; see [Table 13](#)). The combination of the device address (given by the host during enumeration), the endpoint number, and the transfer direction allows each endpoint to be uniquely referenced.

The ISP1521 has two endpoints: endpoint 0 (control) and endpoint 1 (interrupt).

**Table 13. Hub endpoints**

Function	Endpoint identifier	Transfer type	Direction <sup>[1]</sup>	Maximum packet size (bytes)
Hub ports 0 to 7	0	control	OUT	64
			IN	64
	1	interrupt	IN	1

[1] IN: input for the USB host; OUT: output from the USB host.

### 9.1 Endpoint 0

According to the USB specification, all devices must implement a default control endpoint. This endpoint is used by the host to configure the USB device. It provides access to the device configuration and allows generic USB status and control access.

The ISP1521 supports the following descriptor information through its control endpoint 0:

- Device descriptor
- Device\_qualifier descriptor
- Configuration descriptor
- Interface descriptor
- Endpoint descriptor
- Hub descriptor
- Other\_speed\_configuration descriptor

The maximum packet size of this endpoint is 64 B.

### 9.2 Endpoint 1

Endpoint 1 can be accessed only after the hub has been configured by the host (by sending the Set Configuration command). It is used by the ISP1521 to send the status change information to the host.

Endpoint 1 is an interrupt endpoint. The host polls this endpoint once every 255 ms. After the hub is configured, an IN token is sent by the host to request the port change status. If the hub detects no change in the port status, it returns a NAK to this request, otherwise the Status Change byte is sent. [Table 14](#) shows the content of the change byte.



Table 14. Status Change byte: bit allocation

Bit	Name	Value	Description
0	Hub Status Change	0	no change in the hub status
		1	change in the hub status detected
1 to 7	Port n Status Change	0	no change in the status of port n (n = 1 to 7)
		1	change in the status of port n (n = 1 to 7)

## 10. Descriptors

The ISP1521 hub controller supports the following standard USB descriptors:

- Device
- Device\_qualifier
- Other\_speed\_configuration
- Configuration
- Interface
- Endpoint
- Hub

The hub returns descriptors based on the mode of operation: full-speed or high-speed.

Table 15. Device descriptor

Offset (bytes)	Field name	Value (hex)		Comments
		Full-speed	High-speed	
0	bLength	12	12	descriptor length = 18 B
1	bDescriptorType	01	01	type = DEVICE
2	bcdUSB	00	00	refer to <i>Universal Serial Bus Specification Rev. 2.0</i>
3		02	02	
4	bDeviceClass	09	09	HUB_CLASSCODE
5	bDeviceSubClass	00	00	HubSubClassCode
6	bDeviceProtocol	00	01	HubProtocolHSpeedOneTT
7	bMaxPacketSize0	40	40	packet size = 64 B
8	idVendor	CC	CC	Philips Semiconductors vendor ID (04CC); can be customized
9		04	04	
10	idProduct	21	21	the ISP1521 product ID; can be customized
11		15	15	
12	bcdDevice	00	00	device ID; can be customized
13		02	02	
14	iManufacturer	01	01	can be customized
15	iProduct	02	02	can be customized
16	iSerialNumber	03	03	can be customized; this value must be unique
17	bNumConfigurations	01	01	one configuration

Table 16. Device\_qualifier descriptor

Offset (bytes)	Field name	Value (hex)		Comments
		Full-speed	High-speed	
0	bLength	0A	0A	descriptor length = 10 B
1	bDescriptorType	06	06	type = DeviceQualifierType
2	bcdUSB	00	00	refer to <i>Universal Serial Bus Specification Rev. 2.0</i>
3		02	02	
4	bDeviceClass	09	09	HUB_CLASSCODE
5	bDeviceSubClass	00	00	HubSubClassCode
6	bDeviceProtocol	00	01	HubProtocolHSpeedOneTT
7	bMaxPacketSize0	40	40	packet size = 64 B
8	bNumConfigurations	01	01	number of configurations

Table 17. Other\_speed\_configuration descriptor

Offset (bytes)	Field name	Value (hex)		Comments
		Full-speed	High-speed	
0	bLength	09	09	descriptor length = 9 B
1	bDescriptorType	07	07	type = OtherSpeedConfigurationType
2	wTotalLength	19	19	TotalConfByte
3		00	00	
4	bNumInterfaces	01	01	-
5	bConfigurationValue	01	01	-
6	iConfiguration	00	00	no string supported
7	bmAttributes	E0	E0	self-powered
		A0	A0	others
8	bMaxPower	00	00	self-powered

Table 18. Configuration descriptor

Offset (bytes)	Field name	Value (hex)		Comments
		Full-speed	High-speed	
0	bLength	09	09	descriptor length = 9 B
1	bDescriptorType	02	02	type = CONFIGURATION
2	wTotalLength	19	19	total length of configuration, interface and endpoint descriptors = 25 B
3		00	00	
4	bNumInterfaces	01	01	one interface
5	bConfigurationValue	01	01	configuration value = 1
6	iConfiguration	00	00	no configuration string descriptor
7	bmAttributes	E0	E0	self-powered
8	bMaxPower <sup>[1]</sup>	00	00	self-powered

[1] Value in units of 2 mA.

Table 19. Interface descriptor

Offset (bytes)	Field name	Value (hex)		Comments
		Full-speed	High-speed	
0	bLength	09	09	descriptor length = 9 B
1	bDescriptorType	04	04	type = INTERFACE
2	bInterfaceNumber	00	00	-
3	bAlternateSetting	00	00	no alternate setting
4	bNumEndpoints	01	01	status change (interrupt) endpoint
5	bInterfaceClass	09	09	HUB_CLASSCODE
6	bInterfaceSubClass	00	00	HubSubClassCode
7	bInterfaceProtocol	00	00	-
8	bInterface	00	00	no interface string descriptor

Table 20. Endpoint descriptor

Offset (bytes)	Field name	Value (hex)		Comments
		Full-speed	High-speed	
0	bLength	07	07	descriptor length = 7 B
1	bDescriptorType	05	05	type = ENDPOINT
2	bEndpointAddress	81	81	endpoint 1 at address number 1
3	bmAttributes	03	03	interrupt endpoint
4	wMaxPacketSize	01	01	packet size = 1 B
5		00	00	
6	bInterval	FF	0C	polling interval

Table 21. Hub descriptor

Offset (bytes)	Field name	Value (hex)		Comments
		Full-speed	High-speed	
0	bDescLength	09	09	descriptor length = 9 B
1	bDescriptorType	29	29	type = HUB
2	bNbrPorts	07	07	number of enabled downstream facing ports; selectable by the DP/DM strapping
		06	06	
		05	05	
		04	04	
		03	03	
		02	02	
3	wHubCharacteristics	A9	A9	see <a href="#">Table 22</a>
4		00	00	
5	bPwrOn2PwrGood <sup>[1]</sup>	32	32	ganged or individual mode = 100 ms
		00	00	no power switching mode = 0 ms
6	bHubContrCurrent	64	64	-
7	DeviceRemovable	00	00	seven downstream facing ports, no embedded port
8	PortPwrCtrlMask	FF	FF	-

[1] Value in units of 2 ms.

Table 22. wHubCharacteristics bit description

Bit	Function	Value	Description
D0, D1	logical power switching mode	00	ganged
		01	individual and multiple ganged
		10	none
		11	-
D2	compound hub selection	0	non-compound
		1	compound
D3, D4	overcurrent protection mode	00	global
		01	individual and multiple ganged
		10	none
		11	-
D5	-	-	-
D6	-	-	-
D7	port indicator	0	global feature
		1	-

## 11. Hub requests

The hub must react to a variety of requests initiated by the host. Some requests are standard and are implemented by any USB device whereas others are hub-class specific.

### 11.1 Standard USB requests

[Table 23](#) shows supported standard USB requests.

Table 23. Standard USB requests

Request	bmRequestType byte 0 (bits 7 to 0)	bRequest byte 1 (hex)	wValue bytes 2, 3 (hex)	wIndex bytes 4, 5 (hex)	wLength bytes 6, 7 (hex)	Data response
<b>Address</b>						
Set Address	0000 0000	05	device address <sup>[1]</sup>	00, 00	00, 00	none
<b>Configuration</b>						
Get Configuration	1000 0000	08	00, 00	00, 00	01, 00	configuration value
Set Configuration (0)	0000 0000	09	00, 00	00, 00	00, 00	none
Set Configuration (1)	0000 0000	09	01, 00	00, 00	00, 00	none
<b>Descriptors</b>						
Get Configuration Descriptor	1000 0000	06	00, 02	00, 00	length <sup>[2]</sup>	configuration interface and endpoint descriptors
Get Device Descriptor	1000 0000	06	00, 01	00, 00	length <sup>[2]</sup>	device descriptor
Get String Descriptor (0)	1000 0000	06	03, 00	00, 00	length <sup>[2]</sup>	language ID descriptor
Get String Descriptor (1)	1000 0000	06	03, 01	00, 00	length <sup>[2]</sup>	manufacturer string
Get String Descriptor (2)	1000 0000	06	03, 02	00, 00	length <sup>[2]</sup>	product string
Get String Descriptor (3)	1000 0000	06	03, 03	00, 00	length <sup>[2]</sup>	serial number string

Table 23. Standard USB requests ...continued

Request	bmRequestType byte 0 (bits 7 to 0)	bRequest byte 1 (hex)	wValue bytes 2, 3 (hex)	wIndex bytes 4, 5 (hex)	wLength bytes 6, 7 (hex)	Data response
<b>Feature</b>						
Clear Device Feature (Remote_ Wakeup)	0000 0000	01	01, 00	00, 00	00, 00	none
Clear Endpoint (1) Feature (Halt/Stall)	0000 0010	01	00, 00	81, 00	00, 00	none
Set Device Feature (Remote_ Wakeup)	0000 0000	03	01, 00	00, 00	00, 00	none
Set Endpoint (1) Feature (Halt/Stall)	0000 0010	03	00, 00	81, 00	00, 00	none
<b>Status</b>						
Get Device Status	1000 0000	00	00, 00	00, 00	02, 00	device status
Get Interface Status	1000 0001	00	00, 00	00, 00	02, 00	zero
Get Endpoint (0) Status	1000 0010	00	00, 00	00/80, 00 <sup>[3]</sup>	02, 00	endpoint 0 status
Get Endpoint (1) Status	1000 0010	00	00, 00	81, 00	02, 00	endpoint 1 status

[1] Device address: 0 to 127.

[2] Returned value in bytes.

[3] MSB specifies endpoint direction: 0 = OUT, 1 = IN. The ISP1521 accepts either value.

## 11.2 Hub class requests

[Table 24](#) shows hub class requests.

Table 24. Hub class requests

Request	bmRequestType byte 0 (bits 7 to 0)	bRequest byte 1 (hex)	wValue bytes 2, 3 (hex)	wIndex bytes 4, 5 (hex)	wLength bytes 6, 7 (hex)	Data
<b>Descriptor</b>						
Get Hub Descriptor	1010 0000	06	descriptor type and index	00, 00	length <sup>[1]</sup>	descriptor
<b>Feature</b>						
Clear Hub Feature (C_LOCAL_POWER)	0010 0000	01	00, 00	00, 00	00, 00	none
Clear Port Feature	0010 0011	01	feature <sup>[2]</sup> , 00	port <sup>[3]</sup> , 00	00, 00	none
Set Port Feature	0010 0011	03	feature <sup>[2]</sup> , 00	port <sup>[3]</sup> , 00	00, 00	none
<b>Status</b>						
Get Hub Status	1010 0000	00	00, 00	00, 00	04, 00	hub status and change status
Get Port Status	1010 0011	00	00, 00	port <sup>[3]</sup> , 00	04, 00	port status and change status
<b>TT</b>						
ClearTTBuffer	0010 0011	08	Dev_Addr, EP_nr	01, 00	00, 00	none
ResetTT	0010 0000	09	00, 00	01, 00	00, 00	none
GetTTState	1010 0011	10	TT-flags	01, 00	- <sup>[4]</sup>	TT state

Table 24. Hub class requests ...continued

Request	bmRequestType byte 0 (bits 7 to 0)	bRequest byte 1 (hex)	wValue bytes 2, 3 (hex)	wIndex bytes 4, 5 (hex)	wLength bytes 6, 7 (hex)	Data
StopTT	0010 0011	11	00, 00	01, 00	00, 00	none
<b>Test modes</b>						
Test_J	0010 0011	03	15, 00	port <sup>[3]</sup> , 01	00, 00	none
Test_K	0010 0011	03	15, 00	port <sup>[3]</sup> , 02	00, 00	none
Test_SE0_NAK	0010 0011	03	15, 00	port <sup>[3]</sup> , 03	00, 00	none
Test_Packet	0010 0011	03	15, 00	port <sup>[3]</sup> , 04	00, 00	none
Test_Force_Enable	0010 0011	03	15, 00	port <sup>[3]</sup> , 05	00, 00	none

[1] Returned value in bytes.

[2] Feature selector value; see [Table 25](#).

[3] Downstream port identifier: 1 to N where N is the number of enabled ports (2 to 7).

[4] Returns vendor-specific data.

Table 25. Hub class feature selector

Feature selector name	Recipient	Value
C_HUB_LOCAL_POWER	hub	00
C_HUB_OVER_CURRENT	hub	01
PORT_CONNECTION	port	00
PORT_ENABLE	port	01
PORT_SUSPEND	port	02
PORT_OVER_CURRENT	port	03
PORT_RESET	port	04
PORT_POWER	port	08
PORT_LOW_SPEED	port	09
C_PORT_CONNECTION	port	16
C_PORT_ENABLE	port	17
C_PORT_SUSPEND	port	18
C_PORT_OVER_CURRENT	port	19
C_PORT_RESET	port	20
PORT_TEST	port	21
PORT_INDICATOR	port	22

## 11.3 Detailed responses to hub requests

### 11.3.1 Get configuration

This request returns the configuration value of the device. This request returns 1 B of data; see [Table 26](#).

Table 26. Get hub configuration response

Bit	Function	Value	Description
0	configuration value	0	device is not configured
		1	device is configured
1 to 7	reserved	0	-

### 11.3.2 Get device status

This request returns 2 B of data; see [Table 27](#).

Table 27. Get device status response

Bit	Function	Value	Description
0	self-powered	1	self-powered
1	remote wake-up	0	disabled
		1	enabled
2 to 15	reserved	0	-

### 11.3.3 Get interface status

The request returns 2 B of data; see [Table 28](#).

Table 28. Get interface status response

Bit	Function	Value	Description
0 to 15	reserved	0	-

### 11.3.4 Get endpoint status

The request returns 2 B of data; see [Table 29](#).

Table 29. Get endpoint status response

Bit	Function	Value	Description
0	halt	0	endpoint is not halted
		1	endpoint is halted
1 to 15	reserved	0	-

### 11.3.5 Get hub status

The request returns 4 B of data; see [Table 30](#).

Table 30. Get hub status response

Bit	Function	Value	Description
0	local power source	0	local power supply good
		1	local power supply lost (inactive)
1	overcurrent indicator	0	no overcurrent condition currently exists
		1	a hub overcurrent condition exists
2 to 15	reserved	0	-
16	local power status change	0	no change in the local power status
		1	local power status has changed

**Table 30. Get hub status response ...continued**

Bit	Function	Value	Description
17	overcurrent indicator change	0	no change in overcurrent
		1	overcurrent status has changed
18 to 31	reserved	0	-

### 11.3.6 Get port status

This request returns 4 B of data. The first word contains port status bits (wPortStatus), and the next word contains port status change bits (wPortChange). The contents of wPortStatus is given in [Table 31](#), and the contents of wPortChange is given in [Table 32](#).

**Table 31. Get port status response (wPortStatus)**

Bit	Function	Value	Description
0	current connect status	0	no device is present
		1	a device is present on this port
1	port enabled or disabled	0	port is disabled
		1	port is enabled
2	suspend	0	port is not suspended
		1	port is suspended
3	overcurrent indicator	0	no overcurrent condition exists
		1	an overcurrent condition exists
4	reset	0	reset signaling is not asserted
		1	reset signaling is asserted
5 to 7	reserved	0	-
8	port power	0	port is in the powered-off state
		1	port is not in the powered-off state
9	low-speed device attached	0	full-speed or high-speed device is attached
		1	low-speed device is attached
10	high-speed device attached	0	full-speed device is attached
		1	high-speed device is attached
11	port test mode	0	not in port test mode
		1	in port test mode
12	port indicator control	0	displays default colors
		1	displays software controlled color
13 to 15	reserved	0	-

**Table 32. Get port status change response (wPortChange)**

Bit	Function	Value	Description
0	connect status change	0	no change in the current connect status
		1	change in the current connect status
1	port enable or disable change	0	port is enabled
		1	port is disabled



Table 32. Get port status change response (wPortChange) ...continued

Bit	Function	Value	Description
2	suspend change	0	no change
		1	resume complete
3	overcurrent indicator change	0	no change in the overcurrent indicator
		1	change in the overcurrent indicator
4	reset change	0	no change
		1	reset complete
5 to 15	reserved	0	-

## 11.4 Various get descriptors

**bmRequestType** — 1000 0000b

**bmRequest** — GET\_DESCRIPTOR = 6

Table 33. Get descriptor request

Request name	wValue		wIndex	Data
	Descriptor index	Descriptor type	Zero/language ID	
Get device descriptor	00	01	0	device descriptor
Get configuration descriptor	00	02	0	configuration interface and endpoint descriptors
Get language ID string descriptor	00	03	0	language ID support string
Get manufacturer string descriptor	01	03	n	manufacturer string in LANGID n
Get product string descriptor	02	03	n	product string in LANGID n
Get serial number string descriptor	03	03	n	serial number string in LANGID n

## 12. Limiting values

**Table 34. Limiting values**
*In accordance with the Absolute Maximum Rating System (IEC 60134).*

Symbol	Parameter	Conditions	Min	Max	Unit
$V_{CC(3V3)}$	supply voltage (3.3 V)		-0.5	+4.6	V
$V_{REF(5V0)}$	input reference voltage 5.0 V		-0.5	+6.0	V
$V_{I(5V0)}$	input voltage on 5 V buffers	$3.0\text{ V} < V_{CC} < 3.6\text{ V}$	[1] -0.5	+6.0	V
$V_{I(3V3)}$	3.3 V input voltage	$3.0\text{ V} < V_{CC} < 3.6\text{ V}$	-0.5	+4.6	V
$V_{O(3V3)}$	output voltage on 3.3 V buffers		-0.5	+4.6	V
$I_{lu}$	latch-up current	$V_I < 0\text{ V}$ or $V_I > V_{CC}$	-	100	mA
$V_{esd}$	electrostatic discharge voltage	on pins DM1 to DM7, DP1 to DP7, OC1_N to OC7_N, and all $V_{REF(5V0)}$ and GND pins; $I_{LI} < 1\text{ }\mu\text{A}$	[2][3] -4000	+4000	V
		on all other pins; $I_{LI} < 1\text{ }\mu\text{A}$	[2][3] -2000	+2000	V
$T_{stg}$	storage temperature		-40	+125	°C

[1] Valid only when supply voltage is present.

[2] Test method available on request.

[3] Equivalent to discharging a 100 pF capacitor through a 1.5 k $\Omega$  resistor (Human Body Model).

## 13. Recommended operating conditions

**Table 35. Recommended operating ranges**

Symbol	Parameter	Conditions	Min	Typ	Max	Unit
$V_{CC(3V3)}$	supply voltage (3.3 V)		3.0	3.3	3.6	V
$V_{REF(5V0)}$	input reference voltage 5.0 V		[1] 4.5	5.0	5.5	V
$V_{I(3V3)}$	3.3 V input voltage		0	-	$V_{CC}$	V
$V_{I(5V0)}$	input voltage on 5 V tolerant pins		0	-	$V_{REF(5V0)}$	V
$T_{amb}$	ambient temperature		-40	-	+70	°C

[1] All internal pull-up resistors are connected to this voltage.

## 14. Static characteristics

**Table 36. Static characteristics: supply pins**

$V_{CC} = 3.0\text{ V to }3.6\text{ V}$ ;  $T_{amb} = -40\text{ }^{\circ}\text{C to }+70\text{ }^{\circ}\text{C}$ ; unless otherwise specified.

Symbol	Parameter	Conditions	Min	Typ	Max	Unit
<b>Full-speed</b>						
$I_{REF(5V0)}$	supply current 5 V		-	0.5	-	mA
$I_{CC(tot)}$	total supply current	$I_{CC(tot)} = I_{CC1} + I_{CC2} + I_{CC3} + I_{CC4}$	[1][2]	91	-	mA
<b>High-speed</b>						
$I_{CC(tot)}$	total supply current	suspend mode; internal clock stopped	[2][3]	0.5	-	mA
		no device connected	-	183	-	mA
		one active device connected	-	231	-	mA
		two active devices connected	-	276	-	mA
		three active devices connected	-	318	-	mA
		four active devices connected	-	362	-	mA
		five active devices connected	-	400	-	mA
		six active devices connected	-	446	-	mA
	seven active devices connected	-	492	-	mA	

[1] Irrespective of the number of devices connected, the value of  $I_{CC}$  is always 91 mA in full-speed.

[2] Total supply current for 3.3 V supply voltage.

[3] Including  $R_{pu}$  drop current.

**Table 37. Static characteristics: digital input and outputs**

$V_{CC} = 3.0\text{ V to }3.6\text{ V}$ ;  $T_{amb} = -40\text{ }^{\circ}\text{C to }+70\text{ }^{\circ}\text{C}$ ; unless otherwise specified.[1]

Symbol	Parameter	Conditions	Min	Typ	Max	Unit
<b>Digital input pins</b>						
$V_{IL}$	LOW-level input voltage		-	-	0.8	V
$V_{IH}$	HIGH-level input voltage		2.0	-	-	V
$I_{LI}$	input leakage current		-1	-	+1	$\mu\text{A}$
<b>Schmitt-trigger input pins</b>						
$V_{th(LH)}$	positive-going threshold voltage		1.4	-	1.9	V
$V_{th(HL)}$	negative-going threshold voltage		0.9	-	1.5	V
$V_{hys}$	hysteresis voltage		0.4	-	0.7	V
<b>Overcurrent detection pins OC1_N to OC7_N</b>						
$\Delta V_{trip}$	overcurrent detection trip voltage	$\Delta V = V_{CC} - V_{OCn\_N}$	-	84	-	mV
<b>Digital output pins</b>						
$V_{OL}$	LOW-level output voltage		-	-	0.4	V
$V_{OH}$	HIGH-level output voltage		2.4	-	-	V
<b>Open-drain output pins</b>						
$I_{OZ}$	off-state output current		-1	-	+1	$\mu\text{A}$

[1] All pins are 5 V tolerant.

**Table 38. Static characteristics: I<sup>2</sup>C-bus interface block** $V_{CC} = 3.0\text{ V to }3.6\text{ V}$ ;  $T_{amb} = -40\text{ }^{\circ}\text{C to }+70\text{ }^{\circ}\text{C}$ ; unless otherwise specified.

Symbol	Parameter	Conditions	Min	Typ	Max	Unit
<b>Input pin SCL and input/output pin SDA<sup>[1]</sup></b>						
V <sub>IL</sub>	LOW-level input voltage		-	-	0.9	V
V <sub>IH</sub>	HIGH-level input voltage		2.1	-	-	V
V <sub>hys</sub>	hysteresis voltage		0.15	-	-	V
V <sub>OL</sub>	LOW-level output voltage		-	-	0.4	V
t <sub>f</sub>	fall time	C <sub>b</sub> = 10 pF to 400 pF	<sup>[2][3]</sup> -	0	250	ns

[1] All pins are 5 V tolerant.

[2] The bus capacitance (C<sub>b</sub>) is specified in pF. To meet the specification for V<sub>OL</sub> and the maximum rise time (300 ns), use an external pull-up resistor with R<sub>max</sub> = 850 / C<sub>b</sub> kΩ and R<sub>min</sub> = (V<sub>CC</sub> - 0.4) / 3 kΩ.

[3] Output fall time V<sub>IH</sub> to V<sub>IL</sub>.

**Table 39. Static characteristics: USB interface block (DP0 to DP7 and DM0 to DM7)** $V_{CC} = 3.0\text{ V to }3.6\text{ V}$ ;  $T_{amb} = -40\text{ }^{\circ}\text{C to }+70\text{ }^{\circ}\text{C}$ ; unless otherwise specified.

Symbol	Parameter	Conditions	Min	Typ	Max	Unit
<b>Input levels for high-speed</b>						
V <sub>HSSQ</sub>	high-speed squelch detection threshold voltage (differential signal amplitude)	squelch detected	-	-	100	mV
		no squelch detected	150	-	-	mV
V <sub>HSCM</sub>	high-speed data signaling common-mode voltage range		-50	-	+500	mV
<b>Output levels for high-speed</b>						
V <sub>HSOI</sub>	high-speed idle level		-10	-	+10	mV
V <sub>HSOH</sub>	high-speed data signaling HIGH-level voltage		360	-	440	mV
V <sub>HSOL</sub>	high-speed data signaling LOW-level voltage		-10	-	+10	mV
V <sub>CHIRPJ</sub>	Chirp J level (differential voltage)		<sup>[1]</sup> 700	-	1100	mV
V <sub>CHIRPK</sub>	Chirp K level (differential voltage)		<sup>[1]</sup> -900	-	-500	mV
<b>Input levels for full-speed and low-speed</b>						
V <sub>IL</sub>	LOW-level input voltage		-	-	0.8	V
V <sub>IH</sub>	HIGH-level input voltage	driven	2.0	-	-	V
V <sub>IHZ</sub>	HIGH-level input voltage (floating)		2.7	-	3.6	V
V <sub>DI</sub>	differential input sensitivity	DP - DM	0.2	-	-	V
V <sub>CM</sub>	differential common-mode range		0.8	-	2.5	V
<b>Output levels for full-speed and low-speed</b>						
V <sub>OL</sub>	LOW-level output voltage		0	-	0.3	V
V <sub>OH</sub>	HIGH-level output voltage		2.8	-	3.6	V
V <sub>CRS</sub>	output signal crossover voltage		<sup>[2]</sup> 1.3	-	2.0	V
<b>Leakage current</b>						
I <sub>LZ</sub>	off-state leakage current		-1	-	+1	μA
<b>Capacitance</b>						
C <sub>in</sub>	input capacitance	pin to GND	-	-	20	pF

**Table 39. Static characteristics: USB interface block (DP0 to DP7 and DM0 to DM7) ...continued** $V_{CC} = 3.0\text{ V to }3.6\text{ V}$ ;  $T_{amb} = -40\text{ }^{\circ}\text{C to }+70\text{ }^{\circ}\text{C}$ ; unless otherwise specified.

Symbol	Parameter	Conditions	Min	Typ	Max	Unit
<b>Resistance</b>						
$Z_{INP}$	input impedance		10	-	-	M $\Omega$
<b>Termination</b>						
$V_{TERM}$	termination voltage	for pull-up resistor on pin RPU	[3] 3.0	-	3.6	V

[1] For minimum value, the HS termination resistor is disabled and the pull-up resistor is connected. Only during reset, when both the hub and the device are capable of high-speed operation.

[2] Characterized only, not tested. Limits guaranteed by design.

[3] In suspend mode, the minimum voltage is 2.7 V.

## 15. Dynamic characteristics

**Table 40. Dynamic characteristics: system clock timing**

Symbol	Parameter	Conditions	Min	Typ	Max	Unit
<b>Reset</b>						
$t_{W(POR)}$	internal power-on reset pulse width		0.2	-	1	$\mu\text{s}$
$t_{W(RESET\_N)}$	external RESET_N pulse width		0.2	-	-	$\mu\text{s}$
<b>Crystal oscillator</b>						
$f_{clk}$	clock frequency	crystal	[1][2]	12	-	MHz
<b>External clock input</b>						
$\delta$	clock duty cycle		-	50	-	%

[1] Recommended accuracy of the clock frequency is 500 ppm for the crystal.

[2] Suggested values for external capacitors when using a crystal are 22 pF to 27 pF.

**Table 41. Dynamic characteristics: overcurrent sense timing**

$V_{CC} = 3.0\text{ V to }3.6\text{ V}$ ;  $T_{amb} = -40\text{ }^{\circ}\text{C to }+70\text{ }^{\circ}\text{C}$ ; unless otherwise specified.

Symbol	Parameter	Conditions	Min	Typ	Max	Unit
<b>Overcurrent sense pins OC1_N to OC7_N</b>						
$t_{trip}$	overcurrent trip response time from OCn_N LOW to PSWn_N HIGH	see <a href="#">Figure 9</a>	-	-	15	ms

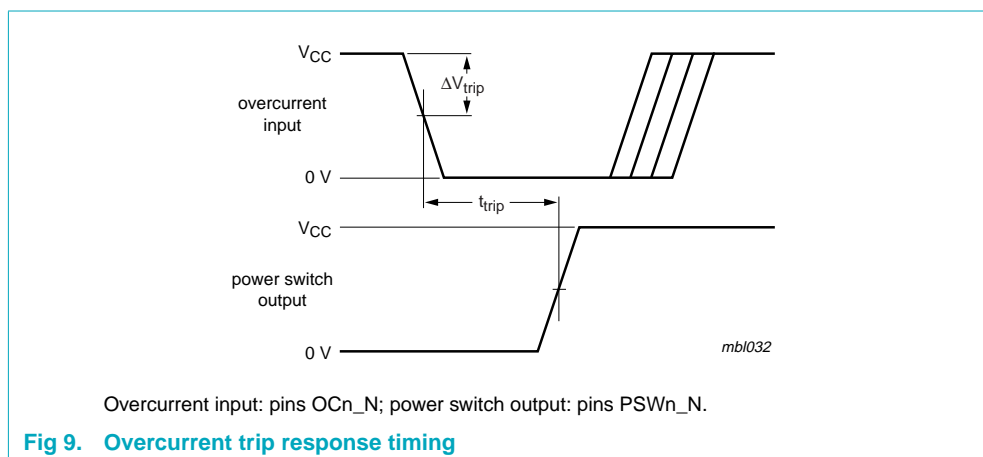

**Table 42. Dynamic characteristics: digital pins**

$V_{CC} = 3.0\text{ V to }3.6\text{ V}$ ;  $T_{amb} = -40\text{ }^{\circ}\text{C to }+70\text{ }^{\circ}\text{C}$ ; unless otherwise specified.[1]

Symbol	Parameter	Conditions	Min	Typ	Max	Unit
$t_{t(HL)}$ , $t_{t(LH)}$	output transition time		4	-	15	ns

[1] All pins are 5 V tolerant.

**Table 43. Dynamic characteristics: high-speed source electrical characteristics** $V_{CC} = 3.0\text{ V to }3.6\text{ V}$ ;  $T_{amb} = -40\text{ }^{\circ}\text{C to }+70\text{ }^{\circ}\text{C}$ ; test circuit [Figure 21](#); unless otherwise specified.

Symbol	Parameter	Conditions	Min	Typ	Max	Unit
<b>Driver characteristics</b>						
$t_{HSR}$	rise time	10 % to 90 %	500	-	-	ps
$t_{HSF}$	fall time	90 % to 10 %	500	-	-	ps
<b>Clock timing</b>						
$t_{HSDRAT}$	high-speed data rate		479.76	-	480.24	Mbit/s
$t_{HSFRAM}$	microframe interval		124.9375	-	125.0625	$\mu\text{s}$
$t_{HSRFI}$	consecutive microframe interval difference		1	-	four high-speed bit times	ns

**Table 44. Dynamic characteristics: full-speed source electrical characteristics** $V_{CC} = 3.0\text{ V to }3.6\text{ V}$ ;  $T_{amb} = -40\text{ }^{\circ}\text{C to }+70\text{ }^{\circ}\text{C}$ ; test circuit [Figure 22](#); unless otherwise specified.

Symbol	Parameter	Conditions	Min	Typ	Max	Unit
<b>Driver characteristics</b>						
$t_{FR}$	rise time	$C_L = 50\text{ pF}$ ; 10 % to 90 % of $ V_{OH} - V_{OL} $	4	-	20	ns
$t_{FF}$	fall time	$C_L = 50\text{ pF}$ ; 90 % to 10 % of $ V_{OH} - V_{OL} $	4	-	20	ns
$t_{FRFM}$	differential rise and fall time matching		[1] 90	-	111.1	%
$V_{CRS}$	output signal crossover voltage		[1][2] 1.3	-	2.0	V
<b>Data source timing</b> <sup>[2]</sup>						
$t_{DJ1}$	source jitter total (including frequency tolerance) to next transition	see <a href="#">Figure 10</a>	[1] -3.5	-	+3.5	ns
$t_{DJ2}$	source jitter total (including frequency tolerance) for paired transitions	see <a href="#">Figure 10</a>	[1] -4	-	+4	ns
$t_{FEOPT}$	source SE0 interval of EOP	see <a href="#">Figure 11</a>	160	-	175	ns
$t_{FDEOP}$	source jitter for differential transition to SE0 transition	see <a href="#">Figure 11</a>	-2	-	+5	ns
<b>Receiver timing</b> <sup>[2]</sup>						
$t_{JR1}$	receiver jitter to next transition	see <a href="#">Figure 12</a>	-18.5	-	+18.5	ns
$t_{JR2}$	receiver jitter for paired transitions	see <a href="#">Figure 12</a>	-9	-	+9	ns
$t_{FEOPR}$	receiver SE0 interval of EOP	accepted as EOP; see <a href="#">Figure 11</a>	82	-	-	ns
$t_{FST}$	width of SE0 interval during differential transition	rejected as EOP; see <a href="#">Figure 13</a>	-	-	14	ns

**Table 44. Dynamic characteristics: full-speed source electrical characteristics ...continued**  
 $V_{CC} = 3.0\text{ V to }3.6\text{ V}$ ;  $T_{amb} = -40\text{ }^{\circ}\text{C to }+70\text{ }^{\circ}\text{C}$ ; test circuit [Figure 22](#); unless otherwise specified.

Symbol	Parameter	Conditions	Min	Typ	Max	Unit
<b>Hub timing (downstream ports configured as full-speed)<sup>[2]</sup></b>						
t <sub>FHDD</sub>	hub differential data delay (without cable)	see <a href="#">Figure 14</a> ; C <sub>L</sub> = 0 pF	-	-	44	ns
t <sub>FSOP</sub>	data bit width distortion after SOP	see <a href="#">Figure 14</a>	-5	-	+5	ns
t <sub>FEOPD</sub>	hub EOP delay relative to t <sub>HDD</sub>	see <a href="#">Figure 15</a>	0	-	15	ns
t <sub>FHESK</sub>	hub EOP output width skew	see <a href="#">Figure 15</a>	-15	-	+15	ns

- [1] Excluding the first transition from idle state.
- [2] Characterized only, not tested. Limits guaranteed by design.

**Table 45. Dynamic characteristics: low-speed source electrical characteristics**  
 $V_{CC} = 3.0\text{ V to }3.6\text{ V}$ ;  $T_{amb} = -40\text{ }^{\circ}\text{C to }+70\text{ }^{\circ}\text{C}$ ; test circuit [Figure 22](#); unless otherwise specified.

Symbol	Parameter	Conditions	Min	Typ	Max	Unit
<b>Driver characteristics</b>						
t <sub>LR</sub>	rise time		75	-	300	ns
t <sub>LF</sub>	fall time		75	-	300	ns
t <sub>LRFM</sub>	rise and fall time matching		[1] 80	-	125	%
V <sub>CRS</sub>	output signal crossover voltage		[1][2] 1.3	-	2.0	V
<b>Hub timing (downstream ports configured as full-speed)</b>						
t <sub>LHDD</sub>	hub differential data delay	see <a href="#">Figure 14</a>	-	-	300	ns
t <sub>LSOP</sub>	data bit width distortion after SOP	see <a href="#">Figure 14</a>	[2] -60	-	+60	ns
t <sub>LEOPD</sub>	hub EOP delay relative to t <sub>HDD</sub>	see <a href="#">Figure 15</a>	[2] 0	-	200	ns
t <sub>LHESK</sub>	hub EOP output width skew	see <a href="#">Figure 15</a>	[2] -300	-	+300	ns

- [1] Excluding the first transition from idle state.
- [2] Characterized only, not tested. Limits guaranteed by design.

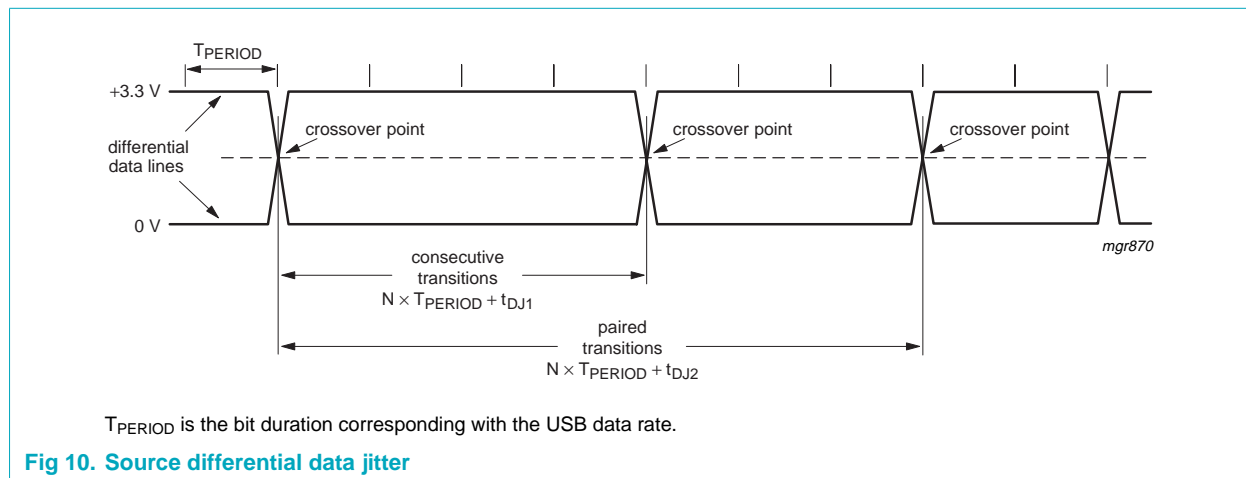



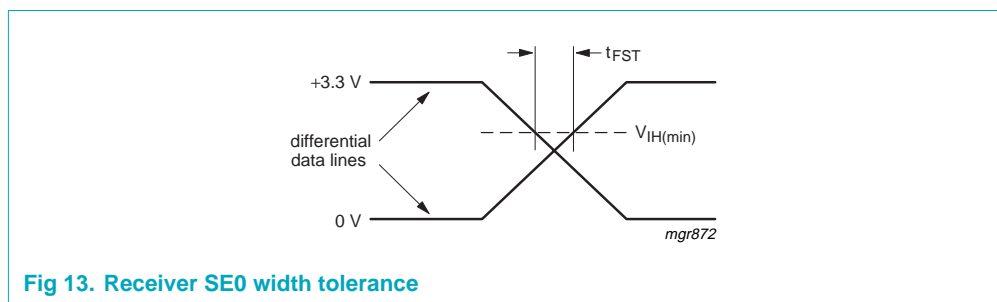
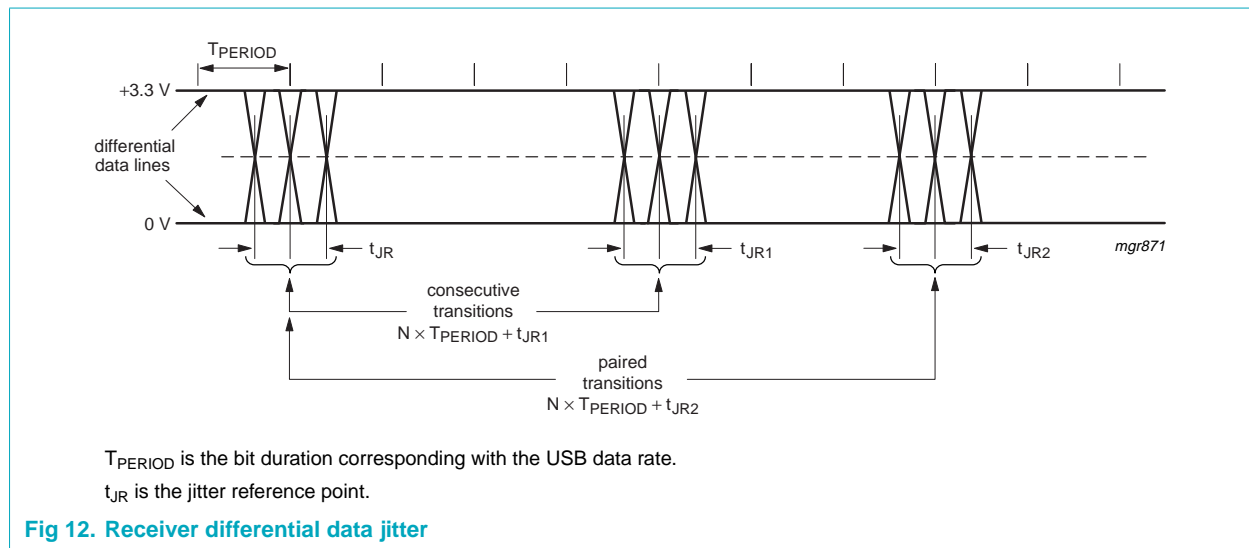
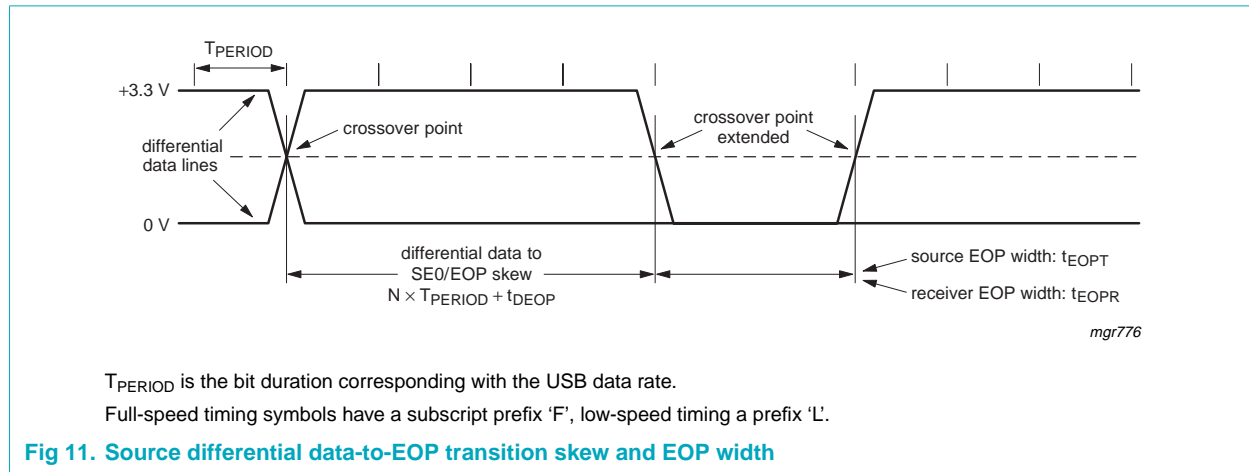

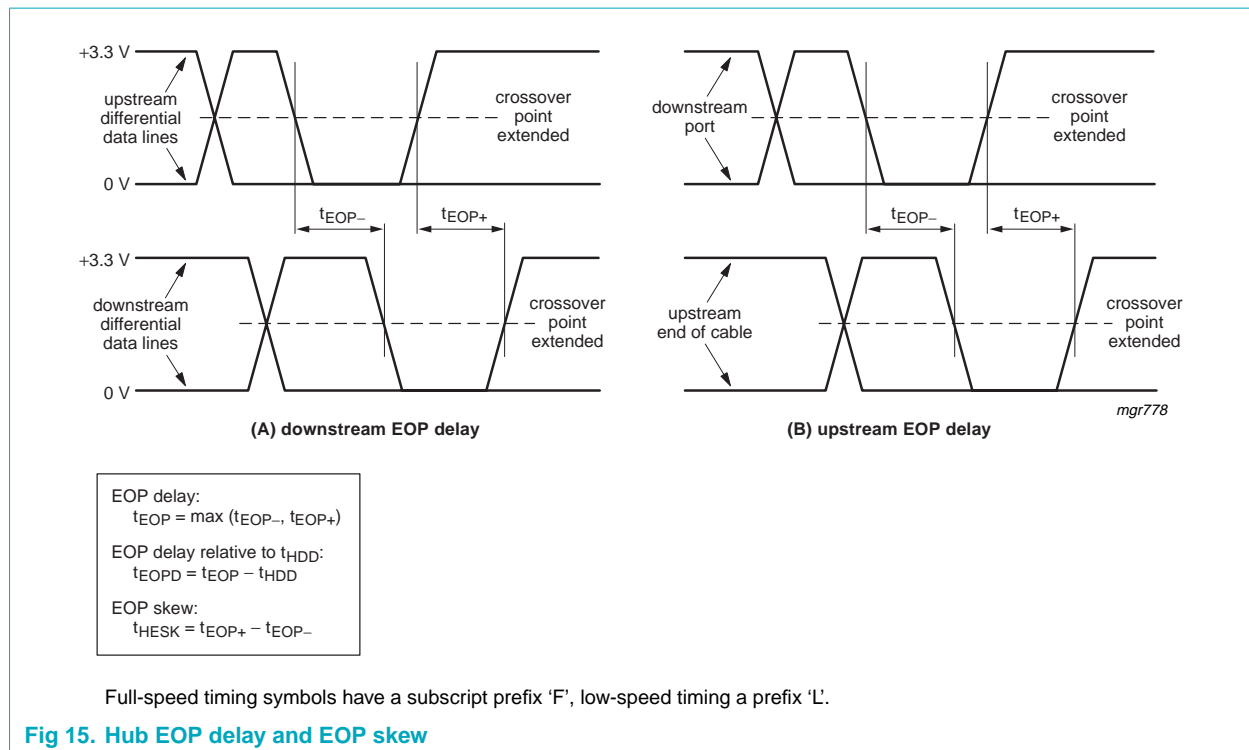
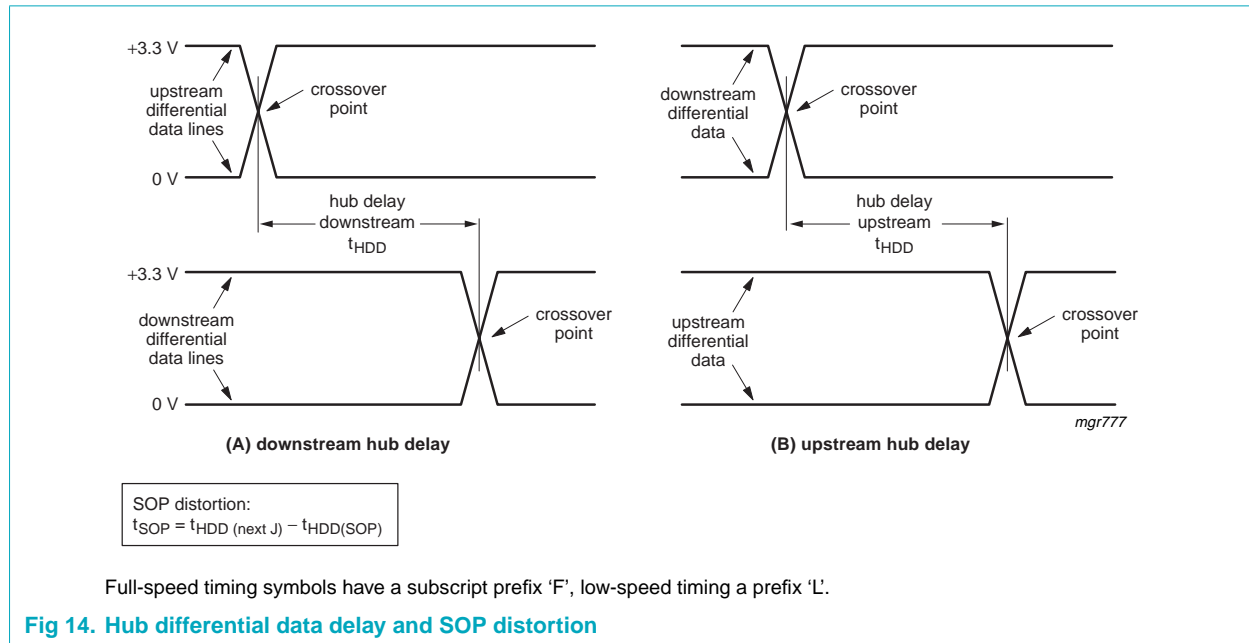

**Table 46. Dynamic characteristics: I<sup>2</sup>C-bus (pins SDA and SCL)**

*V<sub>CC</sub> and T<sub>amb</sub> within recommended operating range; V<sub>DD</sub> = 5 V; V<sub>SS</sub> = V<sub>GND</sub>; V<sub>IL</sub> and V<sub>IH</sub> between V<sub>SS</sub> and V<sub>DD</sub>.*

Symbol	Parameter	Conditions	Min	Typ	Max	Unit
<b>Clock frequency</b>						
f <sub>SCL</sub>	SCL clock frequency	f <sub>XTAL</sub> = 12 MHz	[1] 0	93.75	100	kHz
<b>General timing</b>						
t <sub>(SCL)L</sub>	LOW period of the SCL clock		4.7	-	-	μs
t <sub>(SCL)H</sub>	HIGH period of the SCL clock		4.0	-	-	μs
t <sub>r</sub>	rise time	SDA and SCL signals	[2]	-	1000	ns
t <sub>f</sub>	fall time	SDA and SCL signals	-	-	300	ns
C <sub>b</sub>	capacitive load for each bus line		-	-	400	pF
<b>SDA timing</b>						
t <sub>BUF</sub>	bus free time between a STOP and START condition		4.7	-	-	μs
t <sub>SU;STA</sub>	setup time for the START condition		[3] 4.7	-	-	μs
t <sub>HD;STA</sub>	hold time for the START condition		[4] 4.0	-	-	μs
t <sub>SU;DAT</sub>	data setup time		250	-	-	ns
t <sub>HD;DAT</sub>	data hold time		0	-	-	μs
t <sub>SU;STO</sub>	STOP condition setup time		4.0	-	-	μs
<b>Additional I<sup>2</sup>C-bus timing</b>						
t <sub>VD;DAT</sub>	data valid time		[5]	-	0.4	μs

[1] f<sub>SCL</sub> = 1/64 × f<sub>XTAL</sub>.

[2] Rise time is determined by C<sub>b</sub> and pull-up resistor value R<sub>p</sub> (typical 4.7 kΩ).

[3] Setup time for (repeated) START condition.

[4] Hold time for (repeated) START condition.

[5] SCL LOW to data-out valid time.

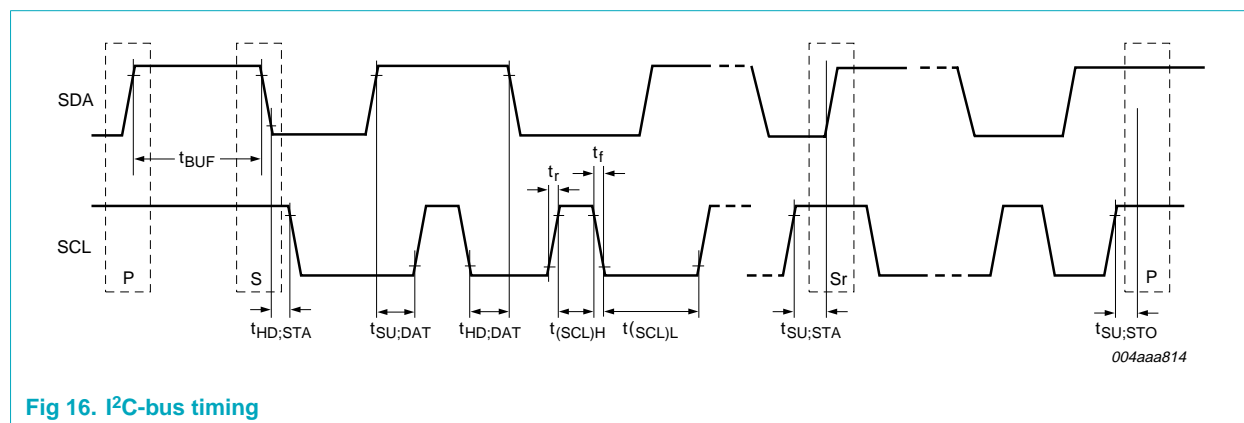

**Fig 16. I<sup>2</sup>C-bus timing**

## 16. Application information

### 16.1 Descriptor configuration selection

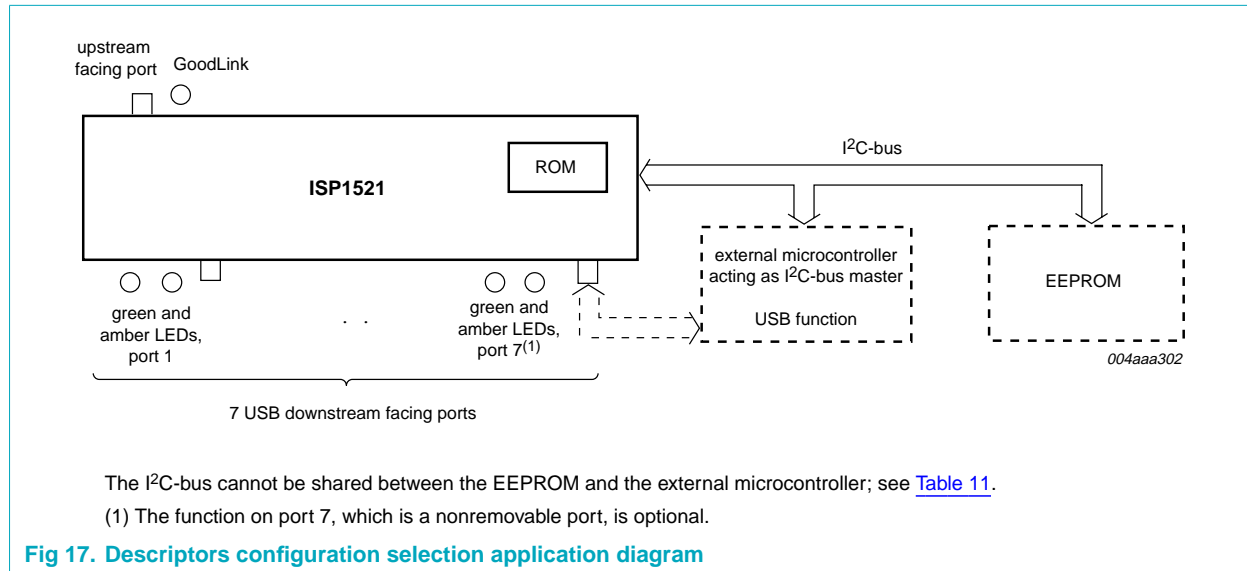

### 16.2 Overcurrent detection limit adjustment

For an overcurrent limit of 500 mA per port, a PMOS with  $R_{DSon}$  of approximately 100 mΩ is required. If a PMOS with a lower  $R_{DSon}$  is used, analog overcurrent detection can be adjusted by using a series resistor; see [Figure 18](#).

$$\Delta V_{PMOS} = \Delta V_{trip} = \Delta V_{trip(intrinsic)} - (I_{OC(nom)} \times R_{adj(oc)}), \text{ where:}$$

$\Delta V_{PMOS}$  = voltage drop on PMOS

$$I_{OC(nom)} = 0.6 \mu A.$$

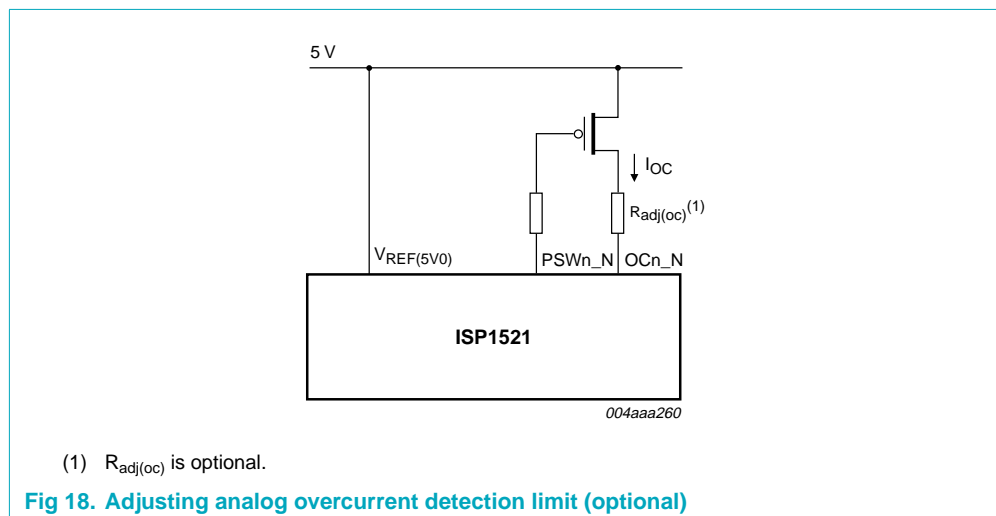

16.3 Self-powered hub configurations

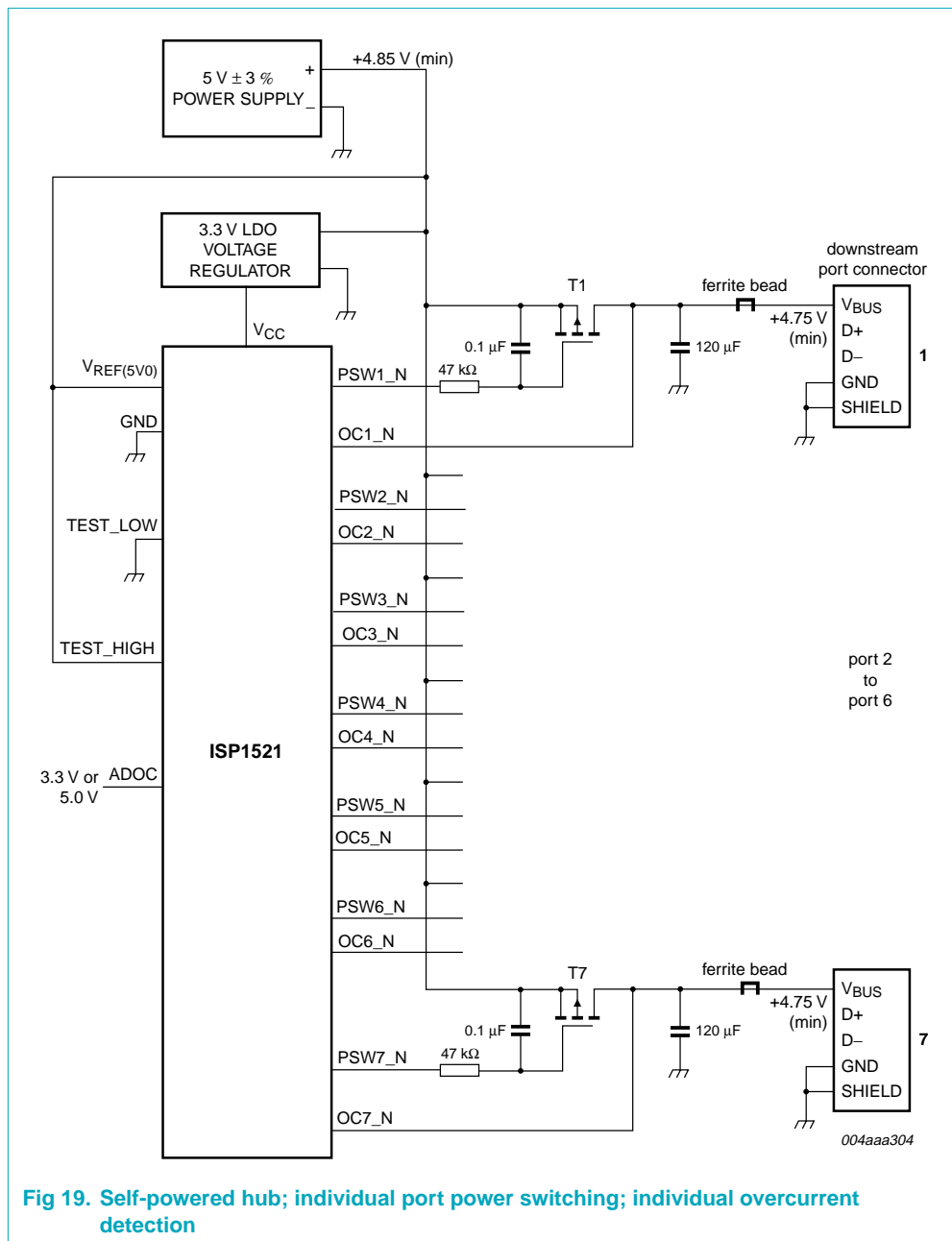

Fig 19. Self-powered hub; individual port power switching; individual overcurrent detection

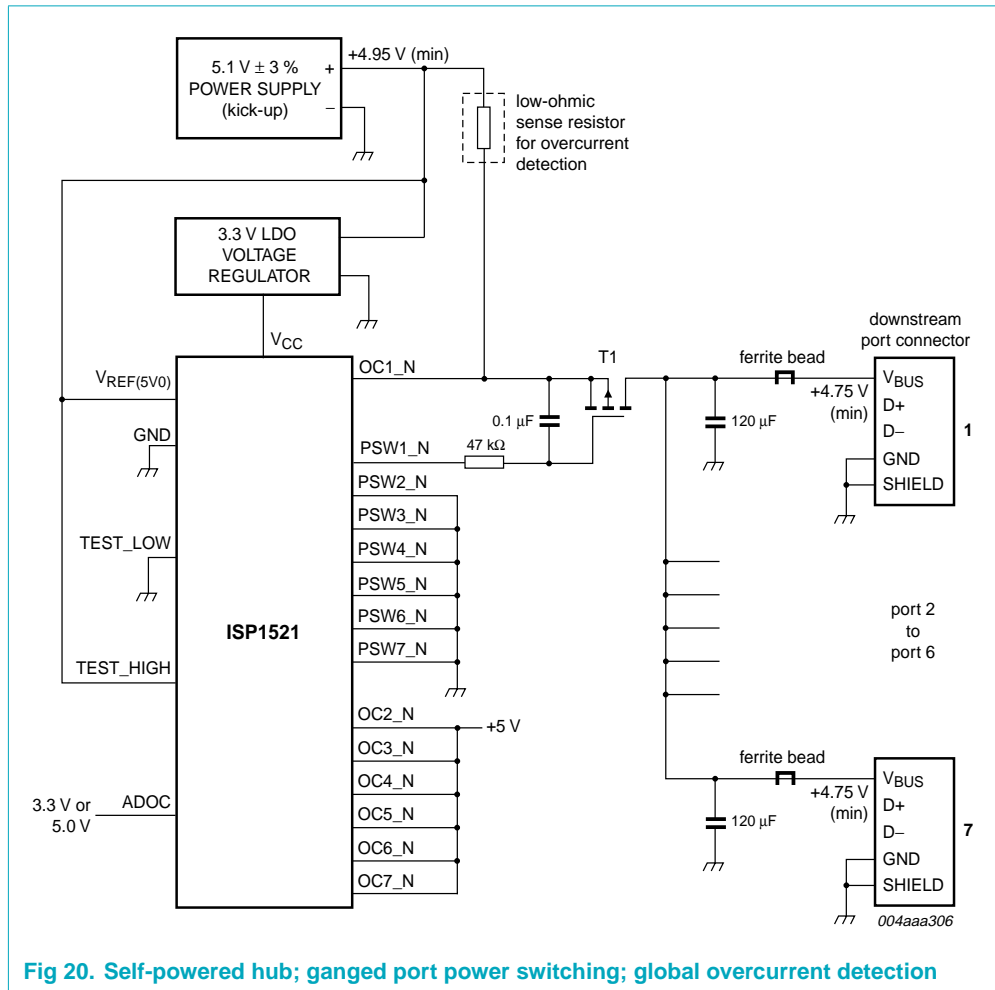
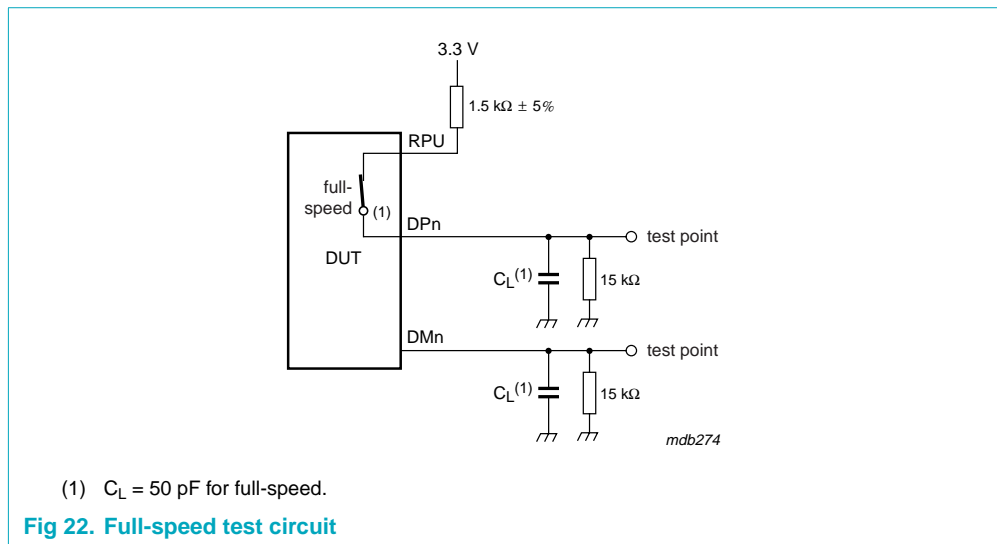
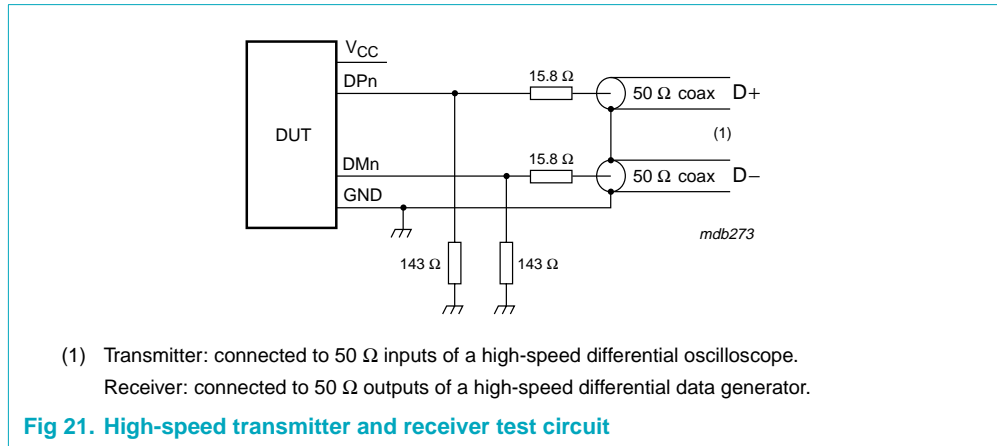

Fig 20. Self-powered hub; ganged port power switching; global overcurrent detection

17. Test information



18. Package outline

LQFP80: plastic low profile quad flat package; 80 leads; body 12 x 12 x 1.4 mm

SOT315-1

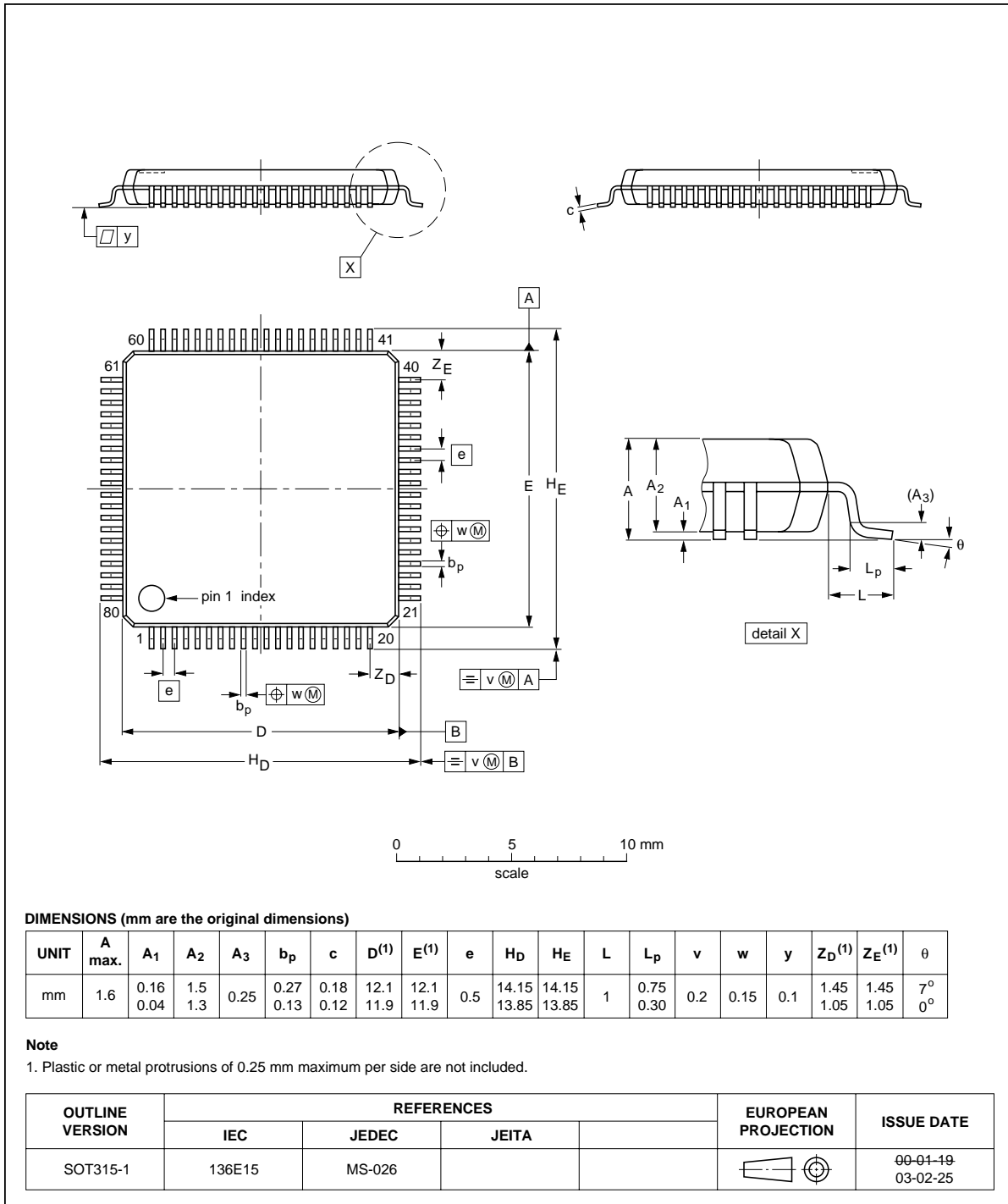

Fig 23. Package outline SOT315-1 (LQFP80)



## 19. Soldering

### 19.1 Introduction to soldering surface mount packages

This text gives a very brief insight to a complex technology. A more in-depth account of soldering ICs can be found in our *Data Handbook IC26; Integrated Circuit Packages* (document order number 9398 652 90011).

There is no soldering method that is ideal for all surface mount IC packages. Wave soldering can still be used for certain surface mount ICs, but it is not suitable for fine pitch SMDs. In these situations reflow soldering is recommended.

### 19.2 Reflow soldering

Reflow soldering requires solder paste (a suspension of fine solder particles, flux and binding agent) to be applied to the printed-circuit board by screen printing, stencilling or pressure-syringe dispensing before package placement. Driven by legislation and environmental forces the worldwide use of lead-free solder pastes is increasing.

Several methods exist for reflowing; for example, convection or convection/infrared heating in a conveyor type oven. Throughput times (preheating, soldering and cooling) vary between 100 seconds and 200 seconds depending on heating method.

Typical reflow peak temperatures range from 215 °C to 270 °C depending on solder paste material. The top-surface temperature of the packages should preferably be kept:

- below 225 °C (SnPb process) or below 245 °C (Pb-free process)
  - for all BGA, HTSSON..T and SSOP..T packages
  - for packages with a thickness  $\geq 2.5$  mm
  - for packages with a thickness  $< 2.5$  mm and a volume  $\geq 350$  mm<sup>3</sup> so called thick/large packages.
- below 240 °C (SnPb process) or below 260 °C (Pb-free process) for packages with a thickness  $< 2.5$  mm and a volume  $< 350$  mm<sup>3</sup> so called small/thin packages.

Moisture sensitivity precautions, as indicated on packing, must be respected at all times.

### 19.3 Wave soldering

Conventional single wave soldering is not recommended for surface mount devices (SMDs) or printed-circuit boards with a high component density, as solder bridging and non-wetting can present major problems.

To overcome these problems the double-wave soldering method was specifically developed.

If wave soldering is used the following conditions must be observed for optimal results:

- Use a double-wave soldering method comprising a turbulent wave with high upward pressure followed by a smooth laminar wave.
- For packages with leads on two sides and a pitch (e):
  - larger than or equal to 1.27 mm, the footprint longitudinal axis is **preferred** to be parallel to the transport direction of the printed-circuit board;

- smaller than 1.27 mm, the footprint longitudinal axis **must** be parallel to the transport direction of the printed-circuit board.

The footprint must incorporate solder thieves at the downstream end.

- For packages with leads on four sides, the footprint must be placed at a 45° angle to the transport direction of the printed-circuit board. The footprint must incorporate solder thieves downstream and at the side corners.

During placement and before soldering, the package must be fixed with a droplet of adhesive. The adhesive can be applied by screen printing, pin transfer or syringe dispensing. The package can be soldered after the adhesive is cured.

Typical dwell time of the leads in the wave ranges from 3 seconds to 4 seconds at 250 °C or 265 °C, depending on solder material applied, SnPb or Pb-free respectively.

A mildly-activated flux will eliminate the need for removal of corrosive residues in most applications.

## 19.4 Manual soldering

Fix the component by first soldering two diagonally-opposite end leads. Use a low voltage (24 V or less) soldering iron applied to the flat part of the lead. Contact time must be limited to 10 seconds at up to 300 °C.

When using a dedicated tool, all other leads can be soldered in one operation within 2 seconds to 5 seconds between 270 °C and 320 °C.

## 19.5 Package related soldering information

**Table 47. Suitability of surface mount IC packages for wave and reflow soldering methods**

Package <sup>[1]</sup>	Soldering method	
	Wave	Reflow <sup>[2]</sup>
BGA, HTSSON..T <sup>[3]</sup> , LBGA, LFBGA, SQFP, SSOP..T <sup>[3]</sup> , TFBGA, VFBGA, XSON	not suitable	suitable
DHVQFN, HBCC, HBGA, HLQFP, HSO, HSOP, HSQFP, HSSON, HTQFP, HTSSOP, HVQFN, HVSON, SMS	not suitable <sup>[4]</sup>	suitable
PLCC <sup>[5]</sup> , SO, SOJ	suitable	suitable
LQFP, QFP, TQFP	not recommended <sup>[5][6]</sup>	suitable
SSOP, TSSOP, VSO, VSSOP	not recommended <sup>[7]</sup>	suitable
CWQCCN..L <sup>[8]</sup> , PMFP <sup>[9]</sup> , WQCCN..L <sup>[8]</sup>	not suitable	not suitable

[1] For more detailed information on the BGA packages refer to the *(LF)BGA Application Note (AN01026)*; order a copy from your Philips Semiconductors sales office.

[2] All surface mount (SMD) packages are moisture sensitive. Depending upon the moisture content, the maximum temperature (with respect to time) and body size of the package, there is a risk that internal or external package cracks may occur due to vaporization of the moisture in them (the so called popcorn effect). For details, refer to the Drypack information in the *Data Handbook IC26; Integrated Circuit Packages; Section: Packing Methods*.

[3] These transparent plastic packages are extremely sensitive to reflow soldering conditions and must on no account be processed through more than one soldering cycle or subjected to infrared reflow soldering with peak temperature exceeding 217 °C ± 10 °C measured in the atmosphere of the reflow oven. The package body peak temperature must be kept as low as possible.

- [4] These packages are not suitable for wave soldering. On versions with the heatsink on the bottom side, the solder cannot penetrate between the printed-circuit board and the heatsink. On versions with the heatsink on the top side, the solder might be deposited on the heatsink surface.
- [5] If wave soldering is considered, then the package must be placed at a 45° angle to the solder wave direction. The package footprint must incorporate solder thieves downstream and at the side corners.
- [6] Wave soldering is suitable for LQFP, QFP and TQFP packages with a pitch (e) larger than 0.8 mm; it is definitely not suitable for packages with a pitch (e) equal to or smaller than 0.65 mm.
- [7] Wave soldering is suitable for SSOP, TSSOP, VSO and VSSOP packages with a pitch (e) equal to or larger than 0.65 mm; it is definitely not suitable for packages with a pitch (e) equal to or smaller than 0.5 mm.
- [8] Image sensor packages in principle should not be soldered. They are mounted in sockets or delivered pre-mounted on flex foil. However, the image sensor package can be mounted by the client on a flex foil by using a hot bar soldering process. The appropriate soldering profile can be provided on request.
- [9] Hot bar soldering or manual soldering is suitable for PMFP packages.

## 20. Abbreviations

**Table 48. Abbreviations**

Acronym	Description
ACPI	Advanced Configuration and Power Interface
CRC	Cyclical Redundancy Check
EEPROM	Electrically Erasable Programmable Read-Only Memory
EMI	ElectroMagnetic Interference
EOP	End-of-Packet
ESD	ElectroStatic Discharge
FET	Field-Effect Transistor
HS	High-Speed
LSB	Least Significant Bit
MSB	Most Significant Bit
MOSFET	Metal Oxide Silicon Field Effect Transistor
NAK	Not Acknowledge
PCB	Printed-Circuit Board
PID	Packet Identifier
PLL	Phase-Locked Loop
SIE	Serial Interface Engine
SOP	Start-of-Packet
TT	Transaction Translator
TTL	Transistor-Transistor Logic
USB	Universal Serial Bus

## 21. References

- [1] Universal Serial Bus Specification Rev. 2.0
- [2] The I<sup>2</sup>C-bus specification
- [3] ISP1521 Hub Demo Board User's Guide

## 22. Revision history

Table 49. Revision history

Document ID	Release date	Data sheet status	Change notice	Supersedes
ISP1521_4	20060330	Product data sheet	-	ISP1521-03
Modifications:	<ul style="list-style-type: none"> <li>• The format of this data sheet has been redesigned to comply with the new presentation and information standard of Philips Semiconductors.</li> <li>• The symbols and parameters have been changed, wherever applicable, to comply with the new presentation and information standard of Philips Semiconductors.</li> <li>• <a href="#">Table 2 "Pin description"</a>: updated description for the SUSPEND and RESET_N pins, also changed type from O to I/O for SUSPEND.</li> <li>• <a href="#">Table 10 "I<sup>2</sup>C-bus slave address"</a>: updated the last column.</li> <li>• <a href="#">Table 44 "Dynamic characteristics: full-speed source electrical characteristics"</a>: data for driver output impedance deleted.</li> </ul>			
ISP1521-03 (9397 750 13702)	20041124	Product data	-	ISP1521-02
ISP1521-02 (9397 750 11691)	20040212	Product data	-	ISP1521-01
ISP1521-01 (9397 750 10691)	20030625	Preliminary data	-	-

## 23. Legal information

### 23.1 Data sheet status

Document status <sup>[1][2]</sup>	Product status <sup>[3]</sup>	Definition
Objective [short] data sheet	Development	This document contains data from the objective specification for product development.
Preliminary [short] data sheet	Qualification	This document contains data from the preliminary specification.
Product [short] data sheet	Production	This document contains the product specification.

[1] Please consult the most recently issued document before initiating or completing a design.

[2] The term 'short data sheet' is explained in section "Definitions".

[3] The product status of device(s) described in this document may have changed since this document was published and may differ in case of multiple devices. The latest product status information is available on the Internet at URL <http://www.semiconductors.philips.com>.

### 23.2 Definitions

**Draft** — The document is a draft version only. The content is still under internal review and subject to formal approval, which may result in modifications or additions. Philips Semiconductors does not give any representations or warranties as to the accuracy or completeness of information included herein and shall have no liability for the consequences of use of such information.

**Short data sheet** — A short data sheet is an extract from a full data sheet with the same product type number(s) and title. A short data sheet is intended for quick reference only and should not be relied upon to contain detailed and full information. For detailed and full information see the relevant full data sheet, which is available on request via the local Philips Semiconductors sales office. In case of any inconsistency or conflict with the short data sheet, the full data sheet shall prevail.

### 23.3 Disclaimers

**General** — Information in this document is believed to be accurate and reliable. However, Philips Semiconductors does not give any representations or warranties, expressed or implied, as to the accuracy or completeness of such information and shall have no liability for the consequences of use of such information.

**Right to make changes** — Philips Semiconductors reserves the right to make changes to information published in this document, including without limitation specifications and product descriptions, at any time and without notice. This document supersedes and replaces all information supplied prior to the publication hereof.

**Suitability for use** — Philips Semiconductors products are not designed, authorized or warranted to be suitable for use in medical, military, aircraft, space or life support equipment, nor in applications where failure or malfunction of a Philips Semiconductors product can reasonably be expected

to result in personal injury, death or severe property or environmental damage. Philips Semiconductors accepts no liability for inclusion and/or use of Philips Semiconductors products in such equipment or applications and therefore such inclusion and/or use is for the customer's own risk.

**Applications** — Applications that are described herein for any of these products are for illustrative purposes only. Philips Semiconductors makes no representation or warranty that such applications will be suitable for the specified use without further testing or modification.

**Limiting values** — Stress above one or more limiting values (as defined in the Absolute Maximum Ratings System of IEC 60134) may cause permanent damage to the device. Limiting values are stress ratings only and operation of the device at these or any other conditions above those given in the Characteristics sections of this document is not implied. Exposure to limiting values for extended periods may affect device reliability.

**Terms and conditions of sale** — Philips Semiconductors products are sold subject to the general terms and conditions of commercial sale, as published at <http://www.semiconductors.philips.com/profile/terms>, including those pertaining to warranty, intellectual property rights infringement and limitation of liability, unless explicitly otherwise agreed to in writing by Philips Semiconductors. In case of any inconsistency or conflict between information in this document and such terms and conditions, the latter will prevail.

**No offer to sell or license** — Nothing in this document may be interpreted or construed as an offer to sell products that is open for acceptance or the grant, conveyance or implication of any license under any copyrights, patents or other industrial or intellectual property rights.

### 23.4 Trademarks

Notice: All referenced brands, product names, service names and trademarks are the property of their respective owners.

**I<sup>2</sup>C-bus** — logo is a trademark of Koninklijke Philips Electronics N.V.

**GoodLink** — is a trademark of Koninklijke Philips Electronics N.V.

## 24. Contact information

For additional information, please visit: <http://www.semiconductors.philips.com>

For sales office addresses, send an email to: [sales.addresses@www.semiconductors.philips.com](mailto:sales.addresses@www.semiconductors.philips.com)

## 25. Tables

Table 1.	Ordering information	2	Table 41.	Dynamic characteristics: overcurrent sense timing	37
Table 2.	Pin description	4	Table 42.	Dynamic characteristics: digital pins	37
Table 3.	Configuration parameters	12	Table 43.	Dynamic characteristics: high-speed source electrical characteristics	38
Table 4.	Downstream facing port number pin configuration	13	Table 44.	Dynamic characteristics: full-speed source electrical characteristics	38
Table 5.	Power switching mode: pin configuration	14	Table 45.	Dynamic characteristics: low-speed source electrical characteristics	39
Table 6.	Overcurrent protection mode pin configuration	15	Table 46.	Dynamic characteristics: I <sup>2</sup> C-bus (pins SDA and SCL)	42
Table 7.	Overcurrent detection mode selection pin configuration	15	Table 47.	Suitability of surface mount IC packages for wave and reflow soldering methods	49
Table 8.	Nonremovable port pin configuration	15	Table 48.	Abbreviations	50
Table 9.	Port indicator support: pin configuration	16	Table 49.	Revision history	51
Table 10.	I <sup>2</sup> C-bus slave address	16			
Table 11.	Configuration method	17			
Table 12.	ROM or EEPROM detailed map	18			
Table 13.	Hub endpoints	23			
Table 14.	Status Change byte: bit allocation	24			
Table 15.	Device descriptor	24			
Table 16.	Device_qualifier descriptor	25			
Table 17.	Other_speed_configuration descriptor	25			
Table 18.	Configuration descriptor	25			
Table 19.	Interface descriptor	26			
Table 20.	Endpoint descriptor	26			
Table 21.	Hub descriptor	26			
Table 22.	wHubCharacteristics bit description	27			
Table 23.	Standard USB requests	27			
Table 24.	Hub class requests	28			
Table 25.	Hub class feature selector	29			
Table 26.	Get hub configuration response	30			
Table 27.	Get device status response	30			
Table 28.	Get interface status response	30			
Table 29.	Get endpoint status response	30			
Table 30.	Get hub status response	30			
Table 31.	Get port status response (wPortStatus)	31			
Table 32.	Get port status change response (wPortChange)	31			
Table 33.	Get descriptor request	32			
Table 34.	Limiting values	33			
Table 35.	Recommended operating ranges	33			
Table 36.	Static characteristics: supply pins	34			
Table 37.	Static characteristics: digital input and outputs	34			
Table 38.	Static characteristics: I <sup>2</sup> C-bus interface block	35			
Table 39.	Static characteristics: USB interface block (DP0 to DP7 and DM0 to DM7)	35			
Table 40.	Dynamic characteristics: system clock timing	37			

continued >>

## 26. Figures

Fig 1.	Block diagram	.3
Fig 2.	Pin configuration	.4
Fig 3.	Power-on reset timing	.11
Fig 4.	External clock with respect to power-on reset	.11
Fig 5.	Typical voltage drop components in self-powered mode using individual overcurrent detection	.14
Fig 6.	Typical voltage drop components in self-powered mode using global overcurrent detection	.14
Fig 7.	Configurable hub descriptors	.17
Fig 8.	ROM or EEPROM map	.18
Fig 9.	Overcurrent trip response timing	.37
Fig 10.	Source differential data jitter	.39
Fig 11.	Source differential data-to-EOP transition skew and EOP width	.40
Fig 12.	Receiver differential data jitter	.40
Fig 13.	Receiver SE0 width tolerance	.40
Fig 14.	Hub differential data delay and SOP distortion	.41
Fig 15.	Hub EOP delay and EOP skew	.41
Fig 16.	I <sup>2</sup> C-bus timing	.42
Fig 17.	Descriptors configuration selection application diagram	.43
Fig 18.	Adjusting analog overcurrent detection limit (optional)	.43
Fig 19.	Self-powered hub; individual port power switching; individual overcurrent detection	.44
Fig 20.	Self-powered hub; ganged port power switching; global overcurrent detection	.45
Fig 21.	High-speed transmitter and receiver test circuit	.46
Fig 22.	Full-speed test circuit	.46
Fig 23.	Package outline SOT315-1 (LQFP80)	.47

continued >>

## 27. Contents

<b>1</b>	<b>General description</b> . . . . .	<b>1</b>	11.2	Hub class requests. . . . .	28
<b>2</b>	<b>Features</b> . . . . .	<b>2</b>	11.3	Detailed responses to hub requests. . . . .	29
<b>3</b>	<b>Applications</b> . . . . .	<b>2</b>	11.3.1	Get configuration . . . . .	29
<b>4</b>	<b>Ordering information</b> . . . . .	<b>2</b>	11.3.2	Get device status . . . . .	30
<b>5</b>	<b>Block diagram</b> . . . . .	<b>3</b>	11.3.3	Get interface status . . . . .	30
<b>6</b>	<b>Pinning information</b> . . . . .	<b>4</b>	11.3.4	Get endpoint status . . . . .	30
6.1	Pinning . . . . .	4	11.3.5	Get hub status . . . . .	30
6.2	Pin description . . . . .	4	11.3.6	Get port status . . . . .	31
<b>7</b>	<b>Functional description</b> . . . . .	<b>9</b>	11.4	Various get descriptors. . . . .	32
7.1	Analog transceivers . . . . .	9	<b>12</b>	<b>Limiting values</b> . . . . .	<b>33</b>
7.2	Hub controller core . . . . .	9	<b>13</b>	<b>Recommended operating conditions</b> . . . . .	<b>33</b>
7.2.1	Philips serial interface engine . . . . .	9	<b>14</b>	<b>Static characteristics</b> . . . . .	<b>34</b>
7.2.2	Routing logic. . . . .	9	<b>15</b>	<b>Dynamic characteristics</b> . . . . .	<b>37</b>
7.2.3	Transaction translator . . . . .	9	<b>16</b>	<b>Application information</b> . . . . .	<b>43</b>
7.2.4	Mini-Host Controller . . . . .	9	16.1	Descriptor configuration selection . . . . .	43
7.2.5	Hub repeater. . . . .	10	16.2	Overcurrent detection limit adjustment. . . . .	43
7.2.6	Hub and port controllers . . . . .	10	16.3	Self-powered hub configurations . . . . .	44
7.2.7	Bit clock recovery . . . . .	10	<b>17</b>	<b>Test information</b> . . . . .	<b>46</b>
7.3	Phase-locked loop clock multiplier . . . . .	10	<b>18</b>	<b>Package outline</b> . . . . .	<b>47</b>
7.4	I <sup>2</sup> C-bus controller . . . . .	10	<b>19</b>	<b>Soldering</b> . . . . .	<b>48</b>
7.5	Overcurrent detection circuit. . . . .	10	19.1	Introduction to soldering surface mount	
7.6	GoodLink . . . . .	10		packages . . . . .	48
7.7	Power-on reset . . . . .	10	19.2	Reflow soldering. . . . .	48
<b>8</b>	<b>Configuration selections</b> . . . . .	<b>12</b>	19.3	Wave soldering. . . . .	48
8.1	Configuration through I/O pins . . . . .	13	19.4	Manual soldering . . . . .	49
8.1.1	Number of downstream facing ports. . . . .	13	19.5	Package related soldering information . . . . .	49
8.1.2	Power switching . . . . .	13	<b>20</b>	<b>Abbreviations</b> . . . . .	<b>50</b>
8.1.2.1	Voltage drop requirements . . . . .	13	<b>21</b>	<b>References</b> . . . . .	<b>50</b>
8.1.3	Overcurrent protection mode . . . . .	14	<b>22</b>	<b>Revision history</b> . . . . .	<b>51</b>
8.1.4	Nonremovable port . . . . .	15	<b>23</b>	<b>Legal information</b> . . . . .	<b>52</b>
8.1.5	Port indicator support . . . . .	15	23.1	Data sheet status . . . . .	52
8.2	Device descriptors and string descriptors		23.2	Definitions . . . . .	52
	settings using I <sup>2</sup> C-bus. . . . .	16	23.3	Disclaimers. . . . .	52
8.2.1	Background information on I <sup>2</sup> C-bus . . . . .	16	23.4	Trademarks . . . . .	52
8.2.1.1	Different conditions on I <sup>2</sup> C-bus. . . . .	16	<b>24</b>	<b>Contact information</b> . . . . .	<b>52</b>
8.2.1.2	Data transfer. . . . .	16	<b>25</b>	<b>Tables</b> . . . . .	<b>53</b>
8.2.1.3	I <sup>2</sup> C-bus address . . . . .	16	<b>26</b>	<b>Figures</b> . . . . .	<b>54</b>
8.2.2	Architecture of configurable hub descriptors . . . . .	17	<b>27</b>	<b>Contents</b> . . . . .	<b>55</b>
8.2.3	ROM or EEPROM map. . . . .	18			
8.2.4	ROM or EEPROM detailed map . . . . .	18			
<b>9</b>	<b>Hub controller description</b> . . . . .	<b>23</b>			
9.1	Endpoint 0. . . . .	23			
9.2	Endpoint 1. . . . .	23			
<b>10</b>	<b>Descriptors</b> . . . . .	<b>24</b>			
<b>11</b>	<b>Hub requests</b> . . . . .	<b>27</b>			
11.1	Standard USB requests . . . . .	27			

Please be aware that important notices concerning this document and the product(s) described herein, have been included in section 'Legal information'.



© Koninklijke Philips Electronics N.V. 2006. All rights reserved.

For more information, please visit: <http://www.semiconductors.philips.com>.

For sales office addresses, email to: [sales.addresses@www.semiconductors.philips.com](mailto:sales.addresses@www.semiconductors.philips.com).

Date of release: 30 March 2006

Document identifier: ISP1521\_4