

FEATURES

- Single Chip Integrated Speech, Audio, Fax and Modem Codec
- Highly Configurable Stereo $\Sigma\Delta$ ADCs and Quad $\Sigma\Delta$ DACs
- Supports V.34, V.32bis, and Fallback Modem Standards As Well As Voice Over Data
- Dual Digital Resamplers with Programmable Input and Output Phase and Frequency
- Three On-Chip Phase Lock Loops for Synchronization to External Signals, Including Video
- Thirteen Analog Inputs and Seven Analog Outputs
- Advanced Analog and Digital Signal Mixing and Digital-to-Digital Sample Rate Conversion
- Programmable Gain, Attenuation and Mute
- On-Chip Signal Filters
- Digital Interpolation and Decimation
- Analog Output Low Pass
- 1 Hz Resolution Programmable Sample Rates from 4 kHz to 54 kHz Derived from a Single Clock Input
- 80-Lead PQFP and 100-Lead TQFP Packages
- Operation from +5 V or Mixed +5 V/+3 V Supplies
- FIFO-Buffered Serial Digital Interface Compatible with ADSP-21xx Fixed-Point DSPs
- Advanced Power Management
- VHDL Model of Serial Port Available; Evaluation Board and MAFE Board Available

GENERAL PRODUCT DESCRIPTION

The AD1843 SoundComm™ Codec is a complete analog front end for high performance DSP-based telephony and audio applications. The device integrates the real-world analog I/O requirements for many popular functions thereby reducing size, power consumption, and system complexity. The AD1843 SoundComm is the world's first codec which can support four different sample rates simultaneously, without any beat frequency noise issues. This is essential for highly integrated audio/modem/fax products since the sample rates associated with audio are very much distinct from the sample rates associated with telephony-oriented data communication. It is also the first codec to offer on-chip digital phase lock loops for sample rate synchronization to external clock signals. This sample rate flexibility is enabled through Analog Devices' Continuous Time Oversampling (CTO) technology.

The main elements of the AD1843 are its extensive input and mixing section, its two channels of sigma-delta ($\Sigma\Delta$) analog-to-digital conversion, its four channels of $\Sigma\Delta$ digital-to-analog conversion, its digital filters, and the clock and control circuitry for implementing the device's different modes. The AD1843 permits flexible sample-rate selection through programming and external synchronization, many input and output options, and many mixing options.

(continued on page 11)

SoundComm is a trademark of Analog Devices, Inc.

SIMPLIFIED FUNCTIONAL BLOCK DIAGRAM

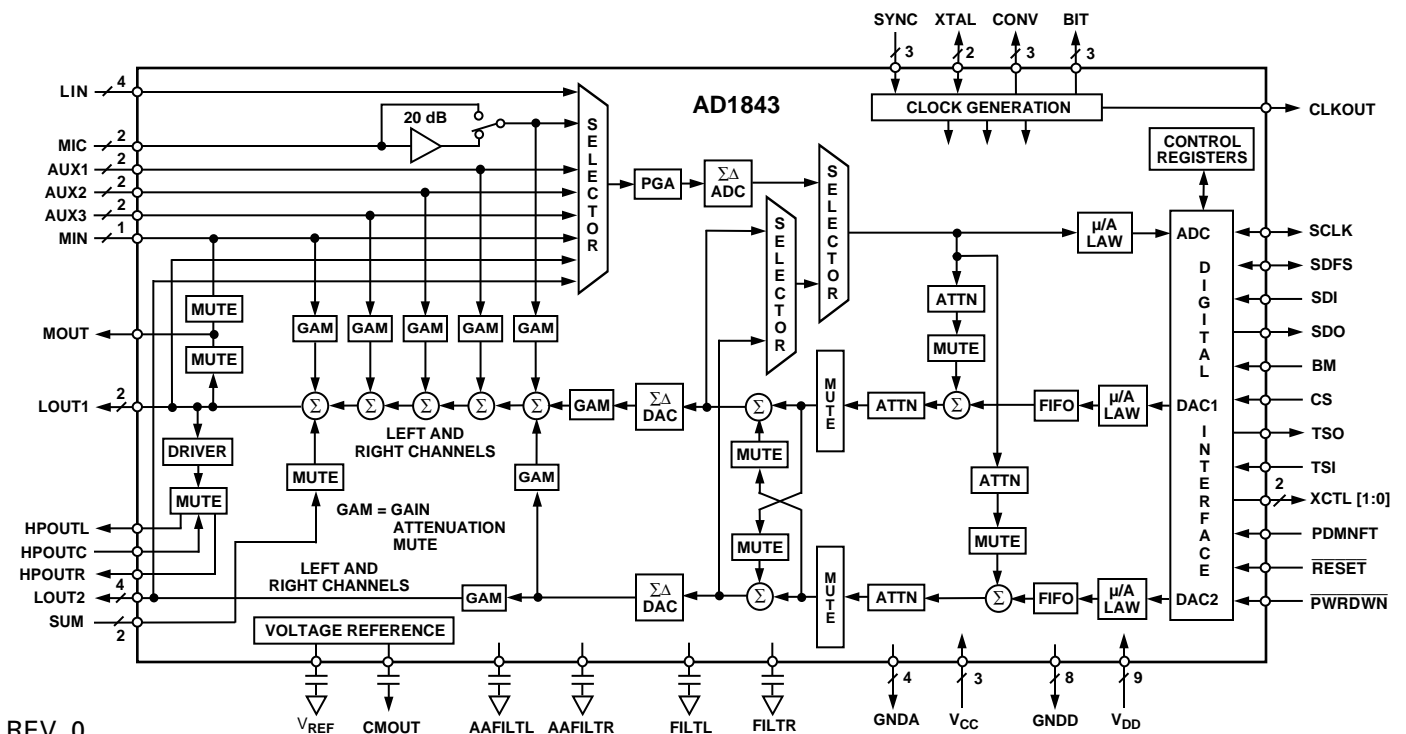

REV. 0

Information furnished by Analog Devices is believed to be accurate and reliable. However, no responsibility is assumed by Analog Devices for its use, nor for any infringements of patents or other rights of third parties which may result from its use. No license is granted by implication or otherwise under any patent or patent rights of Analog Devices.

© Analog Devices, Inc., 1996

One Technology Way, P.O. Box 9106, Norwood, MA 02062-9106, U.S.A.
Tel: 617/329-4700 Fax: 617/326-8703

AD1843—SPECIFICATIONS

STANDARD TEST CONDITIONS UNLESS OTHERWISE NOTED

Temperature	25	°C	<i>DAC Conditions</i>	<i>ADC Input Conditions</i>
Digital Supply (V_{DD})	5.0	V	Autocalibrated	Mic 20 dB Gain Disabled
Analog Supply (V_{CC})	5.0	V	0 dB Attenuation	LIN Single-Ended
Sample Rate (F_S)	48	kHz	0 dB Relative to Full Scale	(LINLSD & LINRSD = 0)
Input Signal	1008	Hz	16-Bit Linear Mode	Autocalibrated
Analog Output Passband	20 Hz to 20 kHz		No Output Load	0 dB PGA Gain
ADC FFT Size	2048		Mute Off	-1.0 dB Relative to Full Scale
DAC FFT Size	8192		DAC1 Single-Ended	Line Input
V_{IH}	2.0	V	DAC2 Differential	16-Bit Linear Mode
V_{IL}	0.8	V		
V_{OH}	2.4	V		
V_{OL}	0.4	V		
I_{OH}	-2	mA		
I_{OL}	2	mA		

ANALOG INPUT

	Min	Typ	Max	Units
Full-Scale Input Voltage (RMS Values Assume Sine Wave Input)				
All Inputs with ADRFLT & ADLFLT = 0 and LINLSD & LINRSD = 0 (LINLP, LINRP, AUX1L, AUX1R, AUX2L, AUX2R, AUX3L, AUX3R, MIN)	2.55	1 2.828	3.1	V rms V p-p
All Inputs with ADRFLT & ADLFLT = 0 and LINLSD & LINRSD = 1 (LINLP & LINLN, LINRP & LINRN)	5.1	2 5.656	6.2	V rms V p-p
All Inputs with ADRFLT & ADLFLT = 1 and LINLSD & LINRSD = 0 (LINLP, LINRP, AUX1L, AUX1R, AUX2L, AUX2R, AUX3L, AUX3R, MIN)	2.8	1.127 3.156	3.5	V rms V p-p
All Inputs with ADRFLT & ADLFLT = 1 and LINLSD & LINRSD = 1 (LINLP & LINLN, LINRP & LINRN)	5.6	2.254 6.312	7.0	V rms V p-p
MIC with +20 dB Gain (LMGE & RMGE = 1 and ADRFLT & ADLFLT = 0) (MICL, MICR)	0.25	0.1 0.2828	0.31	V rms V p-p
MIC with 0 dB Gain (LMGE & RMGE = 0 and ADRFLT & ADLFLT = 0) (MICL, MICR)	2.55	1 2.828	3.1	V rms V p-p
AUX, SUM and MIN Input Impedance* (AUX1L, AUX1R, AUX2L, AUX2R, AUX3L, AUX3R, SUML, SUMR, MIN)	10K			Ω
LIN Input Impedance* (LINLP, LINLN, LINRP, LINRN)	40K			Ω
MIC Input Impedance* (MICL, MICR)	20K			Ω
Input Capacitance* (All Inputs)		15		pF

PROGRAMMABLE GAIN AMPLIFIER-ADC

	Min	Typ	Max	Units
Step Size (0 dB to 22.5 dB) (All Steps Tested)	1.3	1.5	1.7	dB
PGA Gain Range Span*	21.5	22.5	23.5	dB

INPUT (AUX1, AUX2, AUX3, MIN, MIC)

ANALOG AMPLIFIERS/ATTENUATORS

	Min	Typ	Max	Units
Step Size (+12.0 dB to -30 dB) (All Steps Tested)	1.25	1.5	1.75	dB
Step Size (-31.5 dB to -34.5 dB) (All Steps Tested)	1.1	1.5	1.9	dB
Input Gain/Attenuation Range*	45.5	46.5	47.5	dB
Mute Attenuation*		-80.0		dB

DIGITAL DECIMATION AND INTERPOLATION FILTERS–AUDIO MODE*

	Min	Max	Units
Passband	0	$0.40 \times F_S$	Hz
Passband Ripple	0	-0.016	dB
Transition Band	$0.4 \times F_S$	$0.6 \times F_S$	Hz
Stopband ¹	$0.6 \times F_S$		Hz
Stopband Rejection	91.8		dB
Group Delay		$15/F_S$	s
Group Delay Variation Over Passband		0.0	μ s

DIGITAL DECIMATION AND INTERPOLATION FILTERS–MODEM MODE*

	Min	Max	Units
Passband	0	$0.442 \times F_S$	Hz
Passband Ripple	0	-0.220	dB
Transition Band	$0.442 \times F_S$	$0.542 \times F_S$	Hz
Stopband ²	$0.542 \times F_S$		Hz
Stopband Rejection	75.7		dB
Group Delay		$19/F_S$	s
Group Delay Variation Over Passband		0.0	μ s
Sample Rate		24	kHz

DIGITAL DECIMATION AND INTERPOLATION FILTERS–RESAMPLER MODE*

	Min	Max	Units
Passband	0	$0.4 \times F_S$	Hz
Passband Ripple	0	-0.035	dB
Transition Band	$0.4 \times F_S$	$0.5 \times F_S$	Hz
Stopband ³	$0.5 \times F_S$		Hz
Stopband Rejection	92.2		dB
Group Delay		$25/F_S$	s
Group Delay Variation Over Passband		0.0	μ s

ANALOG-TO-DIGITAL CONVERTERS

	Min	Typ	Max	Units
Audio Dynamic Range (-60 dB Input, THD+N Referenced to Full Scale, A-Weighted, ADRFLT & ADLFLT = 0)	80	85		dB
Modem Dynamic Range (-60 dB Input, THD+N Referenced to Full Scale, 300 Hz to 4 kHz Analog Output Passband, LINRSD & LINLSD = 1, ADRFLT & ADLFLT = 1, $F_S = 12.8$ kHz)	87	90		dB
Audio THD+N (Referenced to Full Scale)			0.03	%
			-74	dB
Modem THD+N (-3.0 dB Referenced to Full Scale, 300 Hz to 4 kHz Analog Output Passband, LINRSD & LINLSD = 1, ADRFLT & ADLFLT = 1, $F_S = 12.8$ kHz)			0.02	%
			-78.5	dB
Audio Signal-to-Intermodulation Distortion* (CCIF Method)			-94	dB
ADC Crosstalk*				
LIN Inputs (Input L, Ground R, Read R; Input R, Ground L, Read L)			-80	dB
Line to MIC (Input LIN, Ground and Select MIC, Read Both Channels)			-80	dB
Line to AUX1, AUX2, AUX3, MIN			-80	dB
Interchannel Gain Mismatch (Difference of Gain Errors)			± 0.5	dB
ADC Offset Error		10	50	mV

AD1843

DAC1 DIGITAL-TO-ANALOG CONVERTERS

	Min	Typ	Max	Units
Audio Dynamic Range (–60 dB Input, THD+N Referenced to Full Scale, A-Weighted, DA1FLT = 0)	77	80		dB
Audio THD+N (Referenced to Full Scale, DA1FLT = 0)			0.03	%
		–74	–70	dB
Audio Signal-to-Intermodulation Distortion* (CCIF Method)		–92	–80	dB
Interchannel Gain Mismatch (Difference of Gain Errors)			±0.5	dB
DAC Crosstalk* (Input L, Zero R, Measure LOUT1R; Input R, Zero L, Measure LOUT1L)			–77	dB
Total Out-of-Band Energy* (Measured from $0.6 \times F_S$ to 100 kHz in Audio Mode)			–60	dB
Audible Out-of-Band Energy* (Measured from $0.6 \times F_S$ to 22 kHz in Audio Mode, Tested at $F_S = 8.0$ kHz)			–72	dB

DAC2 DIGITAL-TO-ANALOG CONVERTERS

	Min	Typ	Max	Units
Audio Dynamic Range (–60 dB Input, THD+N Referenced to Full Scale, A-Weighted, DA2FLT = 0)	78	80		dB
Modem Dynamic Range (–60 dB Input, THD+N Referenced to Full Scale, 300 Hz to 4 kHz Analog Output Passband, DA2FLT = 1, RDA2G5:0 & LDA2G5:0 = 000101 [4.5 dB], $F_S = 12.8$ kHz)	87	90		dB
Audio THD+N (Referenced to Full Scale, DA2FLT = 0)			0.03	%
		–77	–70	dB
Modem THD+N (–3.0 dB Referenced to Full Scale, 300 Hz to 4 kHz Analog Output Passband, DA2FLT = 1, RDA2G5:0 & LDA2G5:0 = 000101 [4.5 dB], $F_S = 12.8$ kHz)			0.016	%
		–81	–76	dB
Audio Signal-to-Intermodulation Distortion* (CCIF Method)		–86	–80	dB
Interchannel Gain Mismatch (Difference of Gain Errors)			±0.5	dB
DAC Crosstalk* (Input L, Zero R, Measure LOUT2R; Input R, Zero L, Measure LOUT2L)			–80	dB
Total Out-of-Band Energy* (Measured from $0.6 \times F_S$ to 100 kHz in Audio Mode)			–60	dB
Audible Out-of-Band Energy* (Measured from $0.6 \times F_S$ to 22 kHz in Audio Mode, Tested at $F_S = 8.0$ kHz)			–72	dB
DC Offset		5	25	mV

DAC1 AND DAC2 ANALOG AMPLIFIERS/ATTENUATORS

	Min	Typ	Max	Units
Step Size (+12.0 dB to –30.0 dB) (All Steps Tested)	1.25	1.5	1.75	dB
Step Size (–31.5 dB to –34.5 dB) (All Steps Tested)	1.1	1.5	1.9	dB
Step Size (–36.0 dB to –82.5 dB)*	1.3	1.5	1.7	dB
Output Attenuation Span*	81.5	82.5	83.5	dB
Mute Attenuation*		–80		dB

DIGITAL MIX ATTENUATORS

	Min	Typ	Max	Units
Step Size (0 dB to –94.5 dB)* (All Steps Tested)	1.3	1.5	1.7	dB
Output Attenuation Span*	93.5	94.5	95.5	dB
Mute Attenuation*		–90		dB

ANALOG OUTPUT

	Min	Typ	Max	Units
LOUT1 Full-Scale Output Voltage (RMS Values Assume Sine Wave Input)	1.8	0.707 2.0	2.2	V rms V p-p
LOUT2 Full-Scale Single-Ended Output Voltage (RMS Values Assume Sine Wave Input)	1.8	0.707 2.0	2.2	V rms V p-p
LOUT2 Full-Scale Differential Output Voltage (RMS Values Assume Sine Wave Input)	3.6	1.414 4.0	4.4	V rms V p-p
LOUT1 Output Impedance*			600	Ω
LOUT2 Output Impedance*			1	Ω
LOUT1 External Load Impedance*	10			k Ω
LOUT2 External Load Impedance*	2			k Ω
MOOUT External Load Impedance*	10			k Ω
HPOUT External Load Impedance*	16	32		Ω
HPOUT THD+N (Referenced to Full Scale, 32 Ω External Load Impedance)		0.10		%
Output Capacitance*			-60	dB
External Load Capacitance*			15	pF
CMOUT	2.10	2.25	100	pF
External CMOUT Load Current*			2.40	V
CMOUT Output Impedance*		4		μ A
Mute Click* (Muted Output Minus Unmuted Midscale DAC1 and DAC2 Outputs)			± 5	k Ω mV

SYSTEM SPECIFICATIONS

	Max	Units
System Frequency Response Ripple* (Line-In to Line-Out)	1.0	dB
Differential Nonlinearity*	± 1	Bit
Phase Linearity Deviation*	5	Degrees

STATIC DIGITAL SPECIFICATIONS

	Min	Max	Units
High-Level Input Voltage (V_{IH}) Digital Inputs, Except SCLK XTALI and SCLK	2.0 2.4	$V_{DD} + 0.3$ $V_{DD} + 0.3$	V V
Low-Level Input Voltage (V_{IL})	-0.3	0.8	V
High-Level Output Voltage (V_{OH})	2.4		V
Low-Level Output Voltage (V_{OL})		0.4	V
Input Leakage Current (GO/NOGO Tested)	-10	10	μ A
Output Leakage Current (GO/NOGO Tested)	-10	10	μ A

TIMING PARAMETERS (GUARANTEED OVER OPERATING TEMPERATURE AND DIGITAL SUPPLY RANGE)

	Min	Typ	Max	Units
Serial Data Frame Sync [SDFS] Period (t_1) (Master Mode, FRS = 1 [16 Slots per Frame], SCF = 0 [SCLK = 12.288 MHz])		20.833		μ s
Frame Sync [SDFS] HI Pulse Width (t_2)		80		ns
Clock [SCLK] to Frame Sync [SDFS] Propagation Delay (t_{PD1})			15	ns
Data [SDI] Input Setup Time to SCLK (t_S)	10			ns
Data [SDI] Input Hold Time from SCLK (t_H)	10			ns
Clock [SCLK] to Output Data [SDO] Valid (t_{DV})			15	ns
Clock [SCLK] to Output Data [SDO] Three-State [High-Z] (t_{HZ})			15	ns
Clock [SCLK] to Time Slot Output [TSO] Propagation Delay (t_{PD2})			15	ns
RESET and PWRDWN LO Pulse Width (t_{RPWL})	100			ns

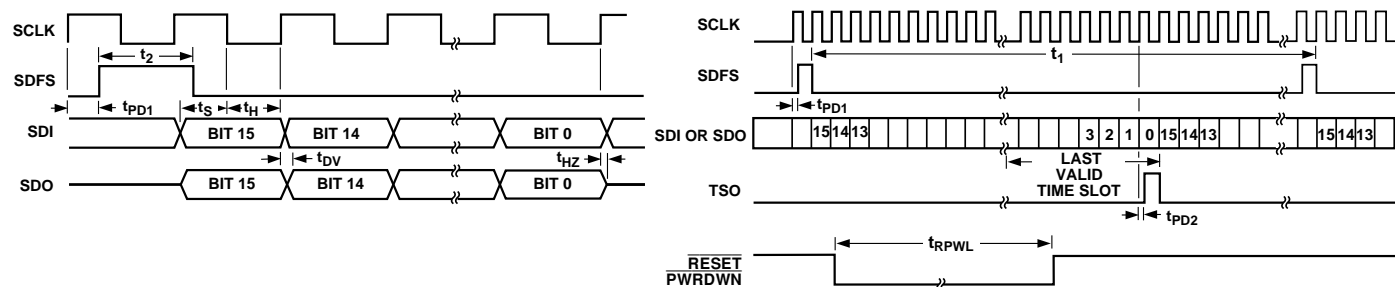

Figure 1. Timing Diagrams

AD1843

POWER SUPPLY (33 Ω HPOUT LOAD)

	Min	Typ	Max	Units
Power Supply Range—Analog V_{CC}	4.75		5.25	V
Power Supply Range—Digital V_{DD}	2.85		5.25	V
Total Power Supply Current—5.0 V_{CC} and V_{DD} Operating (5.0 V_{CC} and V_{DD} Supplies)		210	250	mA
Total Power Supply Current—5.0 V_{CC} /3.0 V_{DD} Operating* (5.0 V_{CC} Analog/3.0 V_{DD} Digital Supplies)		150	175	mA
Analog Supply Current—5.0 V_{CC} Operating		60	75	mA
Digital Supply Current—5.0 V_{DD} Operating		150	175	mA
Digital Supply Current—3.0 V_{DD} Operating*		90	100	mA
Digital Power Supply Current— V_{DD} Power Down (\overline{PWRDWN} LO)			1	mA
Analog Power Supply Current— V_{CC} Power Down (\overline{PWRDWN} LO)			0.5	mA
Power Dissipation—5.0 V_{CC} and V_{DD} Operating (Current × Nominal Supply)			1250	mW
Power Dissipation—5.0 V_{CC} /3.0 V_{DD} Operating* (Current × Nominal Supply)			875	mW
Power Dissipation—5.0 V_{CC} and V_{DD} Power Down (\overline{PWRDWN} LO) (Current × Nominal Supply)			7.5	mW
Power Dissipation—5.0 V_{CC} /3.0 V_{DD} Power Down* (\overline{PWRDWN} LO) (Current × Nominal Supply)			5	mW
Power Supply Rejection (100 mV p-p Signal @ 1 kHz)* (At Both Analog and Digital Supply Pins, for ADC, DAC1 and DAC2)	40			dB

CLOCK SPECIFICATIONS*

	Min	Typ	Max	Units
Input Crystal/Clock Frequency		24.576		MHz
Input Clock Duty Cycle (When an External Clock Is Used Instead of a Crystal)	25/75		75/25	%
Initialization Sample Rate Change Time			0	ms

PACKAGE CHARACTERISTICS

	Typ	Units
PQFP θ_{JA} (Thermal Resistance [Junction-to-Ambient])	96	°C/W
PQFP θ_{JC} (Thermal Resistance [Junction-to-Case])	8.75	°C/W
TQFP θ_{JA} (Thermal Resistance [Junction-to-Ambient])	30.6	°C/W
TQFP θ_{JC} (Thermal Resistance [Junction-to-Case])	4.6	°C/W

NOTES

¹The stopband repeats itself at multiples of $64 \times F_S$, where F_S is the sampling frequency. Thus the audio mode digital filter will attenuate to -91.8 dB or better across the frequency spectrum except for a range of $\pm 0.6 \times F_S$ wide at multiples of $64 \times F_S$.

²The stopband repeats itself at multiples of $64 \times F_S$, where F_S is the sampling frequency. Thus the modem mode digital filter will attenuate to -75.7 dB or better across the frequency spectrum except for a range of $\pm 0.542 \times F_S$ wide at multiples of $64 \times F_S$.

³The stopband repeats itself at multiples of $64 \times F_S$, where F_S is the sampling frequency. Thus the resampler mode digital filter will attenuate to -92.2 dB or better across the frequency spectrum except for a range of $\pm 0.5 \times F_S$ wide at multiples of $64 \times F_S$.

*Guaranteed, not tested.

Specifications subject to change without notice.

ABSOLUTE MAXIMUM RATINGS*

	Min	Max	Units
Power Supplies			
Digital (V_{DD})	-0.3	6.0	V
Analog (V_{CC})	-0.3	6.0	V
Input Current (Except Supply Pins)		± 10.0	mA
Analog Input Voltage (Signal Pins)	-0.3	$V_{CC} + 0.3$	V
Digital Input Voltage (Signal Pins)	-0.3	$V_{DD} + 0.3$	V
Ambient Temperature (Operating)	0	+70	°C
Storage Temperature	-65	+150	°C
ESD Tolerance (Human Body Model per Method 3015.2 of MIL-STD-883B)	1000		V

*Stresses greater than those listed under “Absolute Maximum Ratings” may cause permanent damage to the device. This is a stress rating only and functional operation of the device at these or any other conditions above those indicated in the operational section of this specification is not implied. Exposure to absolute maximum rating conditions for extended periods may affect device reliability.

ORDERING INFORMATION

Model	Temperature Range	Package Description	Package Option
AD1843JS	0°C to +70°C	80-Lead PQFP	S-80
AD1843JST	0°C to +70°C	100-Lead TQFP	ST-100

CAUTION

ESD (electrostatic discharge) sensitive device. Electrostatic charges as high as 4000 V readily accumulate on the human body and test equipment and can discharge without detection. Although the AD1843 features proprietary ESD protection circuitry, permanent damage may occur on devices subjected to high energy electrostatic discharges. Therefore, proper ESD precautions are recommended to avoid performance degradation or loss of functionality.



PIN CONFIGURATIONS
80-Lead PQFP

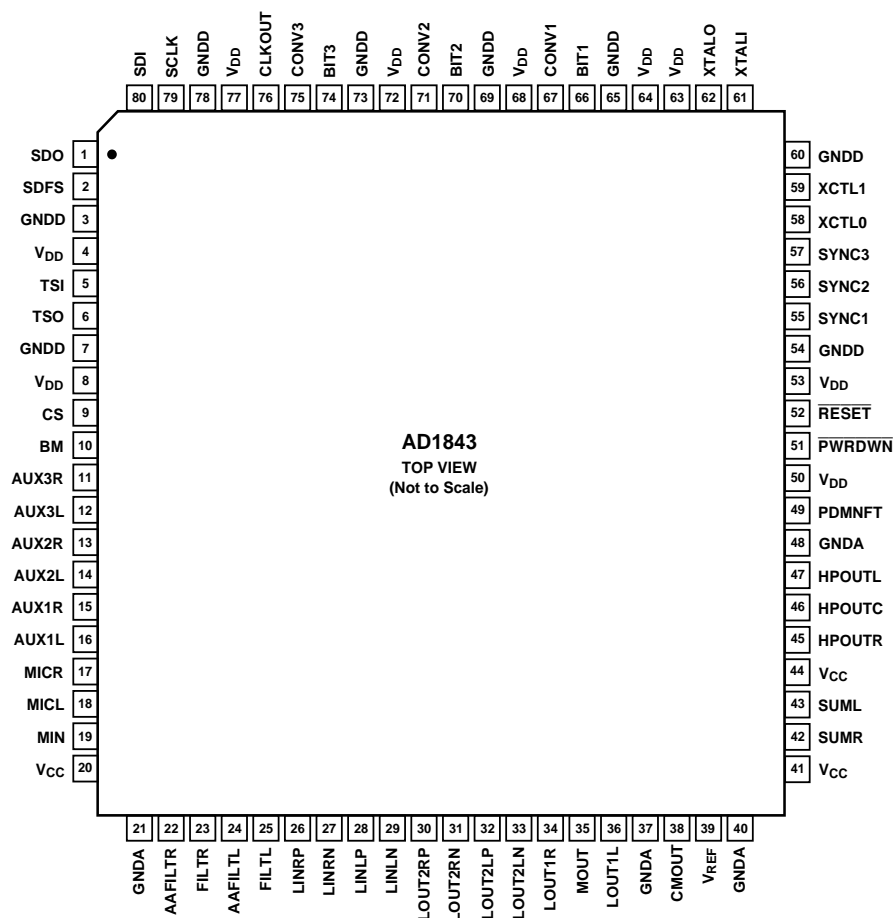

PIN DESCRIPTION

Serial Interface

Pin Name	PQFP	TQFP	I/O	Description
SCLK	79	99	I/O	Serial Clock. SCLK is a bidirectional signal that supplies the clock as an output to the serial bus when the Bus Master (BM) pin is driven HI and accepts the clock as an input when the BM pin is driven LO. When the AD1843 is configured in master mode, the SCLK frequency may be set to either 12.288 MHz or 16.384 MHz with the SCF bit in Control Register Address 26.
SDFS	2	2	I/O	Serial Data Frame Sync. SDFS is a bidirectional signal that supplies the frame synchronization signal as an output to the serial bus when the Bus Master (BM) pin is driven HI and accepts the frame synchronization signal as an input when the BM pin is driven LO.
SDI	80	100	I	Serial Data Input. SDI is used by peripheral devices such as the host CPU or a DSP to supply control and playback data information to the AD1843. All control and playback transfers are 16 bits long, MSB first.
SDO	1	1	O	Serial Data Output. SDO is used to supply status/control register readback and capture data information to peripheral devices such as the host CPU or a DSP. All status/control register readback and capture data transfers are 16 bits long, MSB first. A three-state output driver is used on this pin.
BM	10	12	I	Bus Master. When BM is tied HI the AD1843 is the serial bus master. The AD1843 will then supply the serial clock (SCLK) and the frame sync (SDFS) signals for the serial bus. No more than one device (AD1843/CPU/DSP) should be configured as the serial bus master. When BM is tied LO, the AD1843 is configured as a bus slave, and will accept the SCLK and SDFS signals as inputs. The logic level on this pin must not be changed once <u>RESET</u> is deasserted (driven HI).

PIN CONFIGURATIONS 100-Lead TQFP

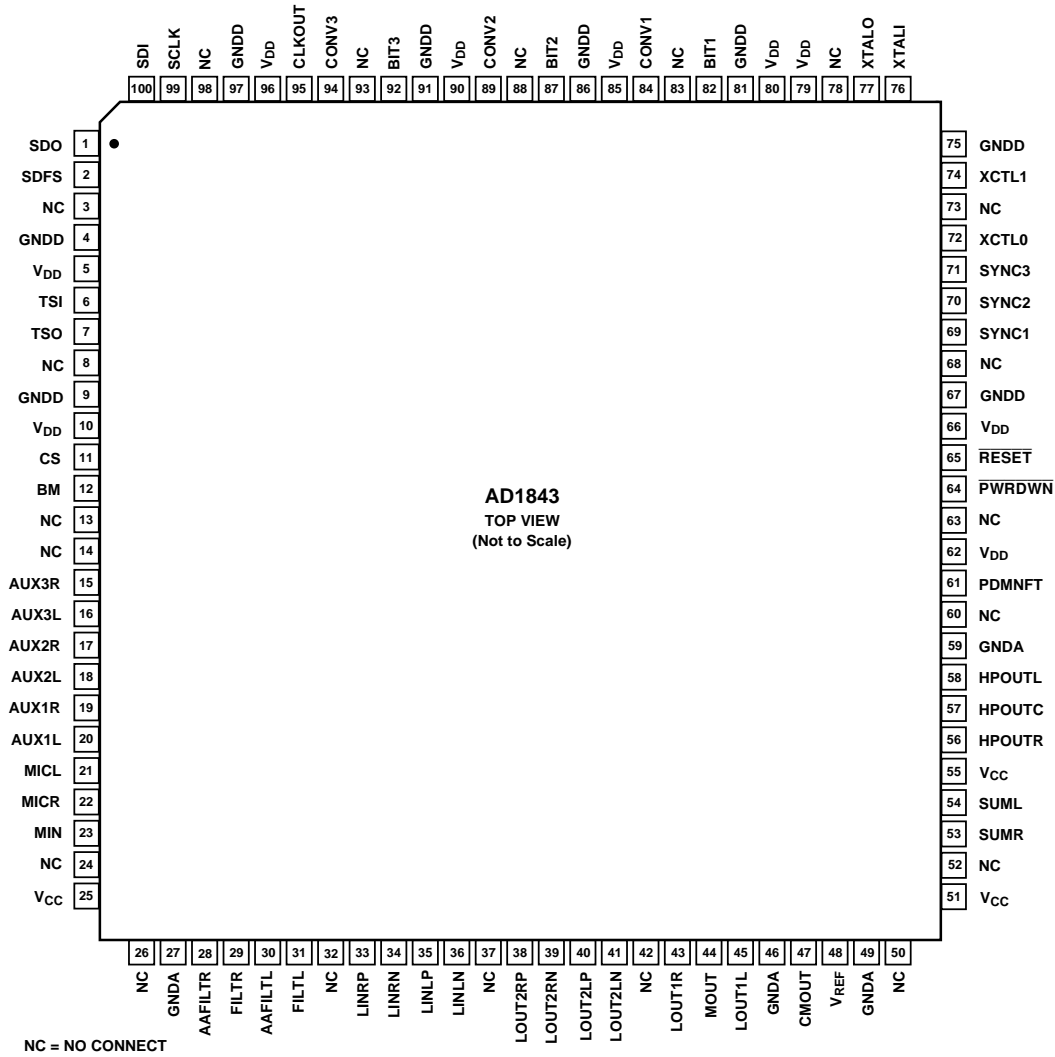

Serial Interface (Continued)

Pin Name	PQFP	TQFP	I/O	Description
CS	9	11	I	Chip Select. When CS is set HI, the serial interface I/O pins will be in their normal active states. When CS is reset LO, SCLK, SDFS, and SDO are three-stated; SCLK, SDFS and SDI inputs are ignored; and TSO drives out the logic level received on TSI.
TSO	6	7	O	Time Slot Output. TSO is asserted HI by the AD1843 simultaneously with the LSB of the last time slot used by the AD1843. It is used to daisy-chain multiple AD1843s on a common TDM serial bus. If the power-down (PWRDWN) pin is asserted or if the chip select pin (CS) is deasserted, TSO is set to the logic level on the TSI pin, allowing powered-down or unselected AD1843s on a daisy-chain to be skipped.
TSI	5	6	I	Time Slot Input. Asserting TSI HI indicates to the AD1843 that it should use the next six time slots beginning on the next SCLK period. It also enables TSO to be asserted at the end of these six time slots. TSI is ignored (but should be tied LO) when the AD1843 is the bus master since the bus master uses the first time slots in a TDM frame.
XCTL[1:0]	59, 58	72, 74	I/O	External Control. These signals reflect the status of bits (Data 8 and 9) in Control Register Address 28 of the AD1843. They may be used for signaling or controlling external logic.

Analog Signals

Pin Name	PQFP	TQFP	I/O	Description
LINLP	28	35	I	Line Input Left Channel Positive Differential Signal.
LINLN	29	36	I	Line Input Left Channel Negative Differential Signal.
LINRP	26	33	I	Line Input Right Channel Positive Differential Signal.
LINRN	27	34	I	Line Input Right Channel Negative Differential Signal.
MICL	18	21	I	Microphone Input Left Channel. Microphone input for the left channel. This signal can be either line level or -20 dB from line level.
MICR	17	22	I	Microphone Input Right Channel. Microphone input for the right channel. This signal can be either line level or -20 dB from line level.
AUX1L	16	20	I	Auxiliary #1 Left Channel Line Input.
AUX1R	15	19	I	Auxiliary #1 Right Channel Line Input.
AUX2L	14	18	I	Auxiliary #2 Left Channel Line Input.
AUX2R	13	17	I	Auxiliary #2 Right Channel Line Input.
AUX3L	12	16	I	Auxiliary #3 Left Channel Line Input.
AUX3R	11	15	I	Auxiliary #3 Right Channel Line Input.
MIN	19	23	I	Monaural (Mono) Line Input.
MOUT	35	44	O	Monaural (Mono) Line Output.
LOUT1L	36	45	O	Line Output #1 Left Channel.
LOUT1R	34	43	O	Line Output #1 Right Channel.
HPOUTL	47	58	O	Headphone Output Left Channel.
HPOUTC	46	57		Headphone Common Return.
HPOUTR	45	56	O	Headphone Output Right Channel.
LOUT2LP	32	40	O	Line Output #2 Left Channel Positive Differential Signal.
LOUT2LN	33	41	O	Line Output #2 Left Channel Negative Differential Signal.
LOUT2RP	30	38	O	Line Output #2 Right Channel Positive Differential Signal.
LOUT2RN	31	39	O	Line Output #2 Right Channel Negative Differential Signal.
SUML	43	54	I	Mixer Line Input Left Channel.
SUMR	42	53	I	Mixer Line Input Right Channel.

Clocks

Pin Name	PQFP	TQFP	I/O	Description
CLKOUT	76	95	O	Clock Output. This signal is a buffered version of XTALO (with a duty cycle restored to at least 60%/40%), the crystal clock output. This pin is enabled by default but can be three-stated by programming a bit in Control Register Address 28. The CLKOUT frequency is 24.576 MHz.
SYNC[3:1]	57, 56, 55	71, 70, 69	I	Sync Inputs. These SYNC signals are used as the clock source inputs to three receptive PLLs in the AD1843. These pins accept a clock at, or at a multiple of, the desired sample rate for A-to-D and D-to-A conversions. These inputs are ignored if a sample rate is programmed directly, but should never be left floating.
CONV[3:1]	75, 71, 67	94, 89, 84	O	Conversion Clock Outputs. These output clocks have an average period equal to (or 128 times) the internal sample rates of the AD1843. These clock outputs are three-stated by default but can be enabled by programming bits in Control Register Address 28.
BIT[3:1]	74, 70, 66	92, 87, 82	O	Bit Clock Outputs. These output clocks can be individually programmed to multiples of the sample rates. Support for V.34 or V.32 bit rates is available. These clock outputs are three-stated by default but can be enabled by programming bits in Control Register Address 28.

AD1843

Miscellaneous

Pin Name	PQFP	TQFP	I/O	Description
XTALI	61	76	I	24.576 MHz Crystal Input. When using a crystal as the clock source, the crystal should be connected between the XTALI and XTALO pins. This crystal should be 24.576 MHz for the normal sampling rate range, i.e., 4 kHz to 54 kHz. A clock input (perhaps the CLKOUT of another AD1843) may be driven into XTALI in place of a crystal. The external clock input must be greater than or equal to 512 times the maximum desired AD1843 sampling frequency.
XTALO	62	77	O	24.576 MHz Crystal Output. When using a crystal as the clock source, the crystal should be connected between the XTALI and XTALO pins. If a clock is driven directly into XTALI, then XTALO should be left unconnected.
$\overline{\text{PWRDWN}}$	51	64	I	Power Down. $\overline{\text{PWRDWN}}$ is active LO. The assertion of this signal will initialize the on-chip Control Registers to their default values, and will completely and quietly power down the AD1843. If a crystal is not connected between XTALI and XTALO, there must be a 24.576 MHz clock input on XTALI for at least 5 ms after this signal is asserted LO for proper operation. The AD1843 will not be completely powered down until after this 5 ms period elapses. The AD1843 always finishes an in-progress power-up sequence before initiating a power-down sequence, and vice versa. If the $\overline{\text{PWRDWN}}$ pin is asserted while a power-up sequence is in progress, the 24.576 MHz clock signal on XTALI must persist for a worst case maximum of 479 ms (power up = 470 ms, autocalibration = 4 ms, power down = 5 ms) after $\overline{\text{PWRDWN}}$ is asserted. When INIT (Control Register Address 0, Bit 15) is set to a "1," the power-down sequence is complete. See the "Power Management" section for important additional details.
$\overline{\text{RESET}}$	52	65	I	Reset. $\overline{\text{RESET}}$ is active LO. The assertion of this signal will initialize the on-chip registers to their default values, and will completely power down the AD1843. $\overline{\text{RESET}}$ is similar to $\overline{\text{PWRDWN}}$, except that when $\overline{\text{PWRDWN}}$ is asserted, power down is "quiet" and performed synchronously to the internal clocks. When $\overline{\text{RESET}}$ is asserted, power down is "noisy" and performed asynchronously to the internal clocks.
PDMNFT	49	61	I	Power-Down Mono Feedthrough. When the AD1843 mixer is powered down, and PDMNFT is asserted HI, the Mono Input (MIN, PQFP Pin 19) is routed to the Mono Output (MOUT, PQFP Pin 35), and the signal applied to MIN will feedthrough to MOUT. When the AD1843 mixer is powered down and PDMNFT is deasserted LO, the feedthrough of MIN to MOUT will be muted. When the AD1843 mixer is not powered down, and MIN to MOUT feedthrough is desired, the Mono Input Mix Mute (Control Register Address 8, Bit 15) and the Mono Output Mute (Control Register Address 8, Bit 6) must be unmuted. During power-down feedthrough, the signal applied to the MIN input appears only at the MOUT output. During normal operation, the signal applied to the MIN input appears at both the MOUT and the LOUT1 outputs. The state of the PDMNFT pin should be changed when the AD1843 mixer is powered up. If the state of PDMNFT is changed when the AD1843 is in total power-down, audible pops and clicks will likely result.
CMOUT	38	47	O	Common-Mode Voltage Output. Nominal 2.25 volt reference available externally for dc-coupling and level-shifting. CMOUT should not be used where it will sink or source current.
V_{REF}	39	48	I	Voltage Reference Filter. Voltage reference filter point for external bypassing only.
FILTL	25	31	I	Left Channel Filter. This pin requires a 1.0 μF capacitor to analog ground for proper operation.
FILTR	23	29	I	Right Channel Filter. This pin requires a 1.0 μF capacitor to analog ground for proper operation.
AAFILTL	24	30	I	Left Channel Antialias Filter. This pin requires a 1000 pF capacitor to analog ground for proper operation.
AAFILTR	22	28	I	Right Channel Antialias Filter. This pin requires a 1000 pF capacitor to analog ground for proper operation.

POWER SUPPLIES

Pin Name	PQFP	TQFP	I/O	Description
V _{CC}	20, 41, 44	25, 51, 55	I	Analog Supply Voltage (+5 V).
GNDA	21, 37, 40, 48	27, 46, 49, 59	O	Analog Ground.
V _{DD}	4, 8, 50, 53, 63, 64, 68, 72, 77	5, 10, 62, 66, 79, 80, 85, 90, 96	I	Digital Supply Voltage (+5/3 V).
GNDD	3, 7, 54, 60, 65, 69, 73, 78	4, 9, 67, 75, 81, 86, 91, 97	I	Digital Ground.
NC		3, 8, 13, 14, 24, 26, 32, 37, 42, 50, 52, 60, 63, 68, 73, 78, 83, 88, 93, 98		No Connect. May be left floating.

(continued from page 1)

The versatility of the device is shown by the following examples of functions it can perform:

- Stereo audio input and/or quad output, simultaneously at different sample rates
- Stereo audio output with simultaneous full duplex modem or fax operation with frequency and phase resampling
- Mono audio input and stereo audio output with simultaneous modem receive and transmit for simultaneous voice and data communications
- Dual independent audio inputs with audio output for echo-cancelling speakerphones

Audio Functional Description

The AD1843 SoundComm codec provides a complete audio solution with very few external components required. Dynamic range of the device exceeds 80 dB over the 20 kHz audio band and sample rates from 4 kHz to 49 kHz are supported (up to 54 kHz for a single channel if other channels are powered down). The audio functionality of this device is a superset of that found in the Analog Devices AD1848 SoundPort[®] device which has set the business audio standard throughout the computer industry.

Inputs to the device include a stereo microphone pair, a stereo line pair, a stereo CD input pair (AUX1), a stereo synthesized music input pair (AUX2), a dual phone line input (AUX3), a mono input, and a stereo input from an FM synthesizer (SUM). All of these inputs (except SUM) are multiplexed to the two $\Sigma\Delta$ A/D converters and are mixable directly as analog signals with the outputs of the D/A converters. All analog input signals (except SUM) can be amplified, attenuated or muted before mixing with the outputs of the D/A converters.

The device has two pairs of $\Sigma\Delta$ DACs which accept 8- or 16-bit digital data from the serial port. Each DAC pair's independent sampling rate can either be programmed by Control Register (with 1 Hz resolution) or synchronized to an external input. The second pair of DACs can be used to replace the music synthesis DAC pair found on many audio products for PCs. Outputs from the AD1843 include a line output, a mono output, a stereo headphone output with its own current return path, and a

differential stereo output for connection to a DAA. The line and differential outputs are looped back to the ADC input selector.

The AD1843's mixing and routing capabilities are extensive. The digital data from both ADC channels after interpolation can be routed back to the ADC decimators, to support digital-to-digital sample rate conversion (digital resampling). Digital data from the ADC can also be routed to the two stereo DAC pairs, for a digital loopback mode which is helpful for device-level and board-level test. Digital data from either stereo DAC can be mixed with the digital data feeding the other DAC, and the analog signal from DAC2 can be mixed with the analog output from DAC1.

Sample rates are independently programmable in the range of 4 kHz to 54 kHz to a 1 Hz resolution or sample rates can be synchronized to an external source. Up to three different signals can be applied to the device's three digital phase lock loop SYNC inputs for external synchronization.

These SYNC inputs can also be used in a special mode for audio/video synchronization. In this mode, an NTSC or PAL derived clock signal (approximately 15 kHz) is applied to the SYNC inputs and the device produces one of a variety of standard audio sample rates (32 kHz, 44.056 kHz, 44.1 kHz and 48 kHz, and most of these divided by the integers 1 through 8). In this manner, video and audio sample rates which are mathematically unrelated can be locked together.

Data Communications/Telephony Functional Description

The AD1843 includes all data conversion, filtering, and clock generation circuitry needed to implement an echo-cancelling modem with a companion digital signal processor. Software-programmable sample rates and clocking modes support all established modem standards including those for the V.34 standard.

The AD1843 utilizes advanced $\Sigma\Delta$ technology to move the entire echo-cancelling modem implementation into the digital domain. The device maintains 90 dB typical dynamic range throughout all filtering and data conversion across a 9.6 kHz passband. Purely DSP-based echo cancellation algorithms can maintain robust bit error rates under worst-case signal attenuation and echo amplitude conditions. The AD1843's on-chip interpolation filter resamples (both frequency and phase) the received signal after echo cancellation in the DSP, freeing the processor for other voice or data communications tasks.

SoundPort is a registered trademark of Analog Devices, Inc.

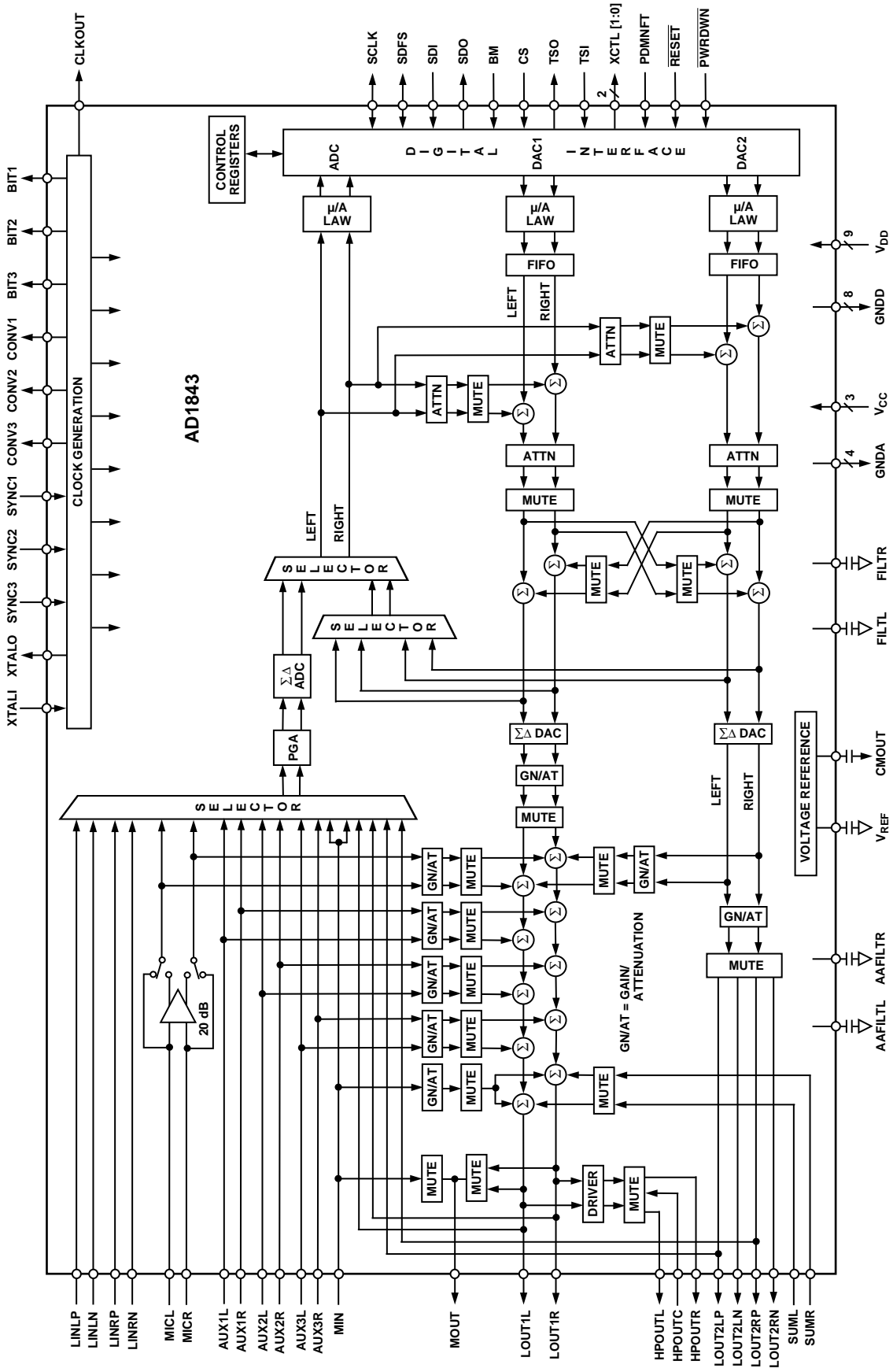

Figure 2. Detailed Functional Block Diagram

On-chip bit and baud clock generation circuitry allows either synchronous or asynchronous operation of the transmit (DAC) and receive (ADC) paths. Each path features independent phase advance and retard adjustments via software control. The AD1843 can also synchronize modem operation to an external terminal band clock. Because the device has multiple input and output channels and converters, it is well suited for telephony applications requiring multiple channels for voice and modem. A detailed block diagram of the AD1843 is shown in Figure 2.

DETAILED PRODUCT DESCRIPTION

The Serial-Port AD1843 SoundComm Codec integrates the key audio and PSTN data conversion and control functions into a single integrated circuit. The AD1843 is intended to provide a complete, single-chip audio and fax/modem solution for PC multimedia applications.

External circuit requirements are limited to a minimal number of low cost support components. Dynamic range exceeds 80 dB over the 20 kHz audio band. Sample rates from 4 kHz to 54 kHz with 1 Hz resolution are supported from a single external crystal or clock source.

The AD1843 SoundComm Codec is intended to be interfaced through a DSP chip or an ASIC to a host bus such as ISA, EISA or PCI. A general system architecture is shown in Figure 3.

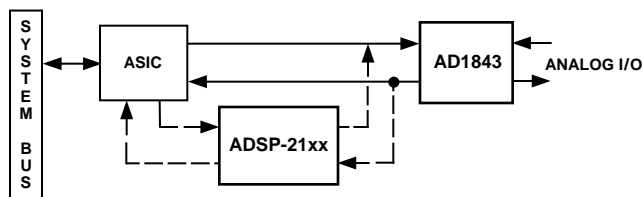

Figure 3. AD1843 System Diagram

The SoundComm codec includes a stereo pair of $\Sigma\Delta$ analog-to-digital converters and two stereo pairs of $\Sigma\Delta$ digital-to-analog converters. Inputs to the ADC can be selected from eight sources of analog signals: stereo line (LIN), stereo microphone (MIC), stereo auxiliary line #1 (AUX1), stereo auxiliary line #2 (AUX2), stereo auxiliary line #3 (AUX3), mono line (MIN), mixer output, and DAC2 output. A mono output and a stereo headphone driver are included on-chip. A stereo line level input (SUM) can be mixed into the output summer. A software-controlled programmable gain stage allows independent gain for each ADC channel. The ADCs' output can be digitally mixed with both the DAC1 and DAC2 inputs. The left and right ADC channels can be configured for different sample rates and digital filter function (audio, modem or resampling).

The pair of 16-bit outputs from the ADCs is available over a serial interface that also supports 16-bit digital input to the DACs and control/status information. The AD1843 can accept and generate 16-bit twos-complement PCM linear digital data, 8-bit unsigned magnitude PCM linear data, and 8-bit μ -law or A-law companded digital data. The data format is defined independently for each conversion resource on the AD1843.

The $\Sigma\Delta$ DACs are preceded by a four sample deep FIFO buffer and a digital interpolation filter. The DAC1 and DAC2 outputs can be mixed in the digital domain. Digital and analog attenuators provide independent user volume control (plus mute) over each DAC channel. Nyquist images and shaped quantized

noise are removed from the DACs' analog stereo output by on-chip switched-capacitor and continuous-time filters. All of the analog inputs (except the stereo line input) can be mixed with the DAC1 output in the analog domain. The DAC2 output can also be mixed with the DAC1 output in the analog domain. The DAC1 and DAC2 digital data can be fed back to the digital half of the ADC to enable digital resampling operation. DAC1 and DAC2 can be run at different sample rates and with different digital filter functions, without any beat frequency problems.

FUNCTIONAL DESCRIPTION

This section overviews the functionality of the AD1843 and is intended as a general introduction to the capabilities of the device. As much as possible, detailed reference information has been placed in "Control Registers" and other sections. The user is not expected to refer repeatedly to this section.

Analog Inputs

The AD1843 SoundComm Codec accepts stereo line-level and mic-level inputs. The mono MIN analog signal input, and LIN (differential), MIC, AUX1, AUX2, AUX3 and post-mixed DAC output analog stereo signals are multiplexed to the internal programmable gain amplifier stage (PGA).

The PGA following the input multiplexer allows left and right independent selectable gains for each channel from 0 dB to 22.5 dB in +1.5 dB steps. The Codec can operate either in a global stereo mode or in a global mono mode with left-channel inputs appearing at both channel outputs.

Analog Mixing

The MIN analog mono signal, and the MIC, AUX1, AUX2, AUX3 and SUM analog stereo signals can be mixed in the analog domain with the DAC1 output. Each channel of each auxiliary analog input can be independently gained/attenuated from +12 dB to -34.5 dB in 1.5 dB steps or completely muted. The mixer output is available on LOUT1 externally and as an input to the ADCs. Even if the AD1843 is not playing back data from its DACs, the analog mix function can still be active.

MIN allows the analog signal intended for the PC speaker to be passed through, attenuated or mixed in the AD1843's analog domain. MIN can be used to accept other mono input sources. A digital control signal pin PDMNFT (Power Down Mono Feed Through) enables the mono input signal to be fed through to the mono output when the AD1843 mixer is powered down.

Analog-to-Digital Datapath

The AD1843 $\Sigma\Delta$ ADCs incorporate a fourth-order modulator. A single pole of passive filtering is all that is required for antialiasing the analog input because of the ADC's high oversampling ratio. The ADCs include linear-phase digital decimation filters that low-pass filter the input. ADC input overrange conditions will cause bits to be set that can be read.

Each channel of the mic inputs can be amplified in the analog domain by +20 dB to compensate for the voltage swing difference between line levels and typical condenser microphone levels.

Digital-to-Analog Datapath

The $\Sigma\Delta$ DACs are preceded by a programmable attenuator and a low-pass digital interpolation filter. The anti-imaging interpolation filter oversamples and digitally filters the higher frequency images. The attenuator allows independent control of each DAC channel from +12.0 dB to -82.5 dB in 1.5 dB steps plus full mute. The DACs' $\Sigma\Delta$ noise shapers oversample and convert the signal to a single-bit stream. The DAC outputs are then

AD1843

filtered in the analog domain by a combination of switched-capacitor and continuous-time filters. They remove the very high frequency components of the DAC bitstream output. No external components are required. Phase linearity at the analog output is achieved by internally compensating for the group delay variation of the analog output filters.

Changes in DAC output attenuation may be programmed to take effect immediately, or only on zero crossings of the digital signal, thereby eliminating “zipper” noise on playback. Each channel has its own independent zero-crossing detector and attenuator change control circuitry. A timer guarantees that requested volume changes will occur even in the absence of an input signal that changes sign. The time-out period is 8 milliseconds at a 48 kHz sampling rate and 48 milliseconds at an 8 kHz sampling rate. (Time-out [ms] $\approx 384 \div F_s$ [kHz]).

Digital Mixing

Stereo digital output from the ADCs can be mixed digitally with the input to the DACs. Digital output from the ADCs going out of the serial port is unaffected by this digital mix. Along the digital mix datapath, the 16-bit linear output from the ADCs is attenuated by an amount specified with Control Register bits. The level of attenuation applied to the left and right channels is independently programmable. (Note that internally the AD1843 always works with 16-bit PCM linear data, digital mixing included; format conversions take place at the input and output.) Sixty-four steps of -1.5 dB attenuation are supported to -94.5 dB. The digital mix datapath can also be completely muted, preventing any mixing of the analog input with the analog output. Note that the level of the mixed signal is also a function of the input PGA settings, since they affect the ADCs’ output. The sample rate of the ADCs and the selected DAC pair must be the same for the digital mix function to operate properly.

The attenuated digital mix data is digitally summed with the DAC input data prior to the DACs’ datapath attenuators. The digital sum of digital mix data and DAC input data is clipped at plus or minus full scale and does not wrap around. Because both stereo signals are mixed before the output attenuators, mix data is attenuated a second time by the DACs’ datapath attenuators. In case the AD1843 is playing back data but input digital DAC data fails to arrive in time (“DAC underrun”), then a midscale zero will be added to the digital mix data in place of the unavailable DAC data.

Analog Outputs

The two mixer line-level outputs are available at external pins. Each output channel can be independently muted. When muted, the outputs will settle to a dc value near CMOUT, the midscale reference voltage. The two DAC2 stereo outputs are available at external pins differentially. The full-scale level on these pins is established by programming bits in a Control Register. In addition, there is stereo headphone output (with a current return), and a mono output. Both the headphone output and the mono output have a single mute control.

Digital Data Types

The AD1843 supports four data types: 16-bit two’s-complement linear PCM, 8-bit unsigned linear PCM, 8-bit companded μ -law, and 8-bit companded A-law, as specified by control register bits. The data type is independently assignable for each conversion resource (i.e., ADCL, ADCR, DAC1 and DAC2). Data in all four formats is always transferred MSB first. Eight-bit data is always left-justified in 16-bit fields; said in other words, the MSBs of all data types are always aligned; in yet other words, full-scale

representations in all four formats correspond to equivalent full-scale signals. The eight least-significant bit positions of 8-bit data in 16-bit fields are ignored on input and zeroed on output.

The 16-bit PCM data format is capable of representing 96 dB of dynamic range. Eight-bit PCM can represent 48 dB of dynamic range. Companded μ -law and A-law data formats use nonlinear coding with less precision for large-amplitude signals. The loss of precision is compensated for by an increase in dynamic range to 64 dB and 72 dB, respectively.

On input, 8-bit companded data is expanded to an internal linear representation, according to whether μ -law or A-law was specified in the Codec’s internal registers. Note that when μ -law compressed data is expanded to a linear format, it requires 14 bits. A-law data expanded requires 13 bits.

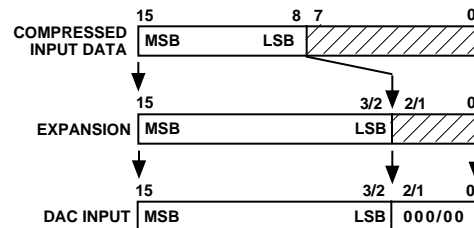

Figure 4. μ -Law or A-Law Expansion

When 8-bit companding is specified, the ADCs’ linear output is compressed to the format specified.

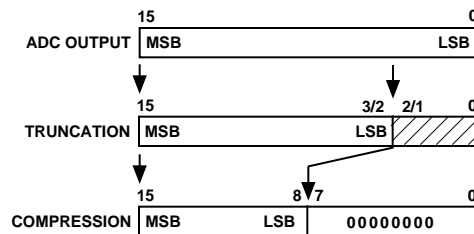

Figure 5. μ -Law or A-Law Compression

Note that all format conversions take place at input or output.

Power Supplies and Voltage Reference

The AD1843 operates from either +5.0 V analog (V_{CC}) and digital (V_{DD}) power supplies or +5.0 V analog and +3.0 V digital supplies. Independent analog and digital supplies are recommended for optimal performance though excellent results can be obtained in single-supply systems. A voltage reference is included on the Codec and its +2.25 V buffered output is available on an external pin (CMOUT). The reference output can be used for biasing op amps used in single supply systems. The internal reference is externally bypassed to analog ground at the V_{REF} pin.

Clocks and Sample Rates

The AD1843 operates from a single external clock or crystal source. From a single clock, a wide range of sample rates can be generated. When supplied with a single 24.576 MHz clock, the AD1843 can be programmed to generate any sample frequency between 4 kHz and 54 kHz with 1 Hz resolution. For modem sample rate support, the frequency programmed can also be increased by 8/7 using a control bit. All sample rate changes can be made “on the fly.”

The AD1843’s SYNC inputs can be used to synchronize the sampling activity of the four on-chip conversion resources to external clock signals, such as video HSYNC or an ISDN network clock. The SYNC inputs are used by three on-chip digital phase

lock loops, which can be arbitrarily assigned to the conversion resources. The lock range of these digital PLLs is 4 kHz to 54 kHz, which is the same range supported by the register-controlled clock generators.

If a SYNC input stops after its associated phase lock loop has had a chance to initially lock, the AD1843 will continue to generate a sample clock (as well as BIT clock and CONV clock) very similar to the initial frequency, but off by at most $\pm 1\%$. The three SYNC inputs feed three on-chip Digital Phase Lock Loops (DPLLs) which utilize a first-order loop filter with a 20 Hz corner frequency. Jitter frequencies above 20 Hz are attenuated, and jitter frequencies below 20 Hz are interpreted as time base drift, and are tracked. The DPLL provides 12 dB per octave of jitter rejection. The DPLLs have been designed to tolerate at least 2% Unit Interval (UI) of SYNC clock jitter. The DPLLs are critically damped at all input frequencies.

Power Management

The AD1843 SoundComm codec has extensive power management capabilities. Hardware power down is performed using the PWRDWN pin. Software power management is programmed using Control Register Address 27 and 28. Several elements of the AD1843 can be powered down on a selective basis. These blocks include: the DAC2 to DAC1 analog mixer; the entire DAC1 conversion channel; the entire DAC2 conversion channel; the analog half of the ADC, DAC1 and DAC2; the headphone driver; the entire analog mixer; the right ADC channel; the left ADC channel; all

four conversion channels; clock generator 1; clock generator 2; clock generator 3; conversion clock outputs 1 through 3; bit clock outputs 1 through 3; and the nominal 24.576 MHz clock output. Refer to the descriptions of Control Register Address 27 and 28 for further information.

For proper operation, the AD1843 must be calibrated following power-up. This initial calibration occurs automatically without any user intervention or programming. Subsequent to this initial power-up autocalibration, there is no requirement to recalibrate the SoundComm codec following software power-down sequences. The entire AD1843 or selected portions of the device may be powered down, allowed to idle indefinitely, then powered up and used immediately, without the need for repeated autocalibration. The digital information obtained during the initial power-up calibration is retained and valid unless the $\overline{\text{RESET}}$ or $\overline{\text{PWRDWN}}$ pin is asserted, forcing a hardware reset. (If desired, the user can specify that a calibration cycle occur when leaving the software power-down state by setting ACEN (Control Register Address 28, Bit 14) to "1.") A hardware reset or power-down clears the calibration information, and therefore a fresh autocalibration cycle is performed by the AD1843 following this event. Autocalibration takes approximately 4 ms to complete.

The following table provides an indication of the power savings associated with powering-down the various resources in the AD1843. Note that the power savings is somewhat order-

Table I. AD1843 Power-Down Savings

+5 V Digital, +5 V Analog Supplies	Total Active Operation Current: 200 mA	Average, Typical Absolute $I_{DD} + I_{CC}$ Current	Average, Typical Normalized Power Savings
Software Power Down	Control Register Bit(s)		
CLKOUT Output	ENCLKO Bit = 0	8 mA	4%
All Bit Clocks and All Conversion Clocks	ENBT3, ENBT2, ENBT1 Bits = 0 ENCV3, ENCV2, ENCV1 Bits = 0	2 mA	1%
Clock Generator 1	C1EN Bit = 0	6 mA	3%
Clock Generator 2	C2EN Bit = 0	6 mA	3%
Clock Generator 3	C3EN Bit = 0	6 mA	3%
All Clock Generators	C1EN, C2EN, C3EN Bits = 0	20 mA	10%
Headphone Driver	HPEN Bit = 0	8 mA	4%
DAC2 to DAC1 Mix	DDMEN Bit = 0	2 mA	1%
Analog Input to Analog Output Mix	AAMEN Bit = 0	8 mA	4%
ADC Left Channel	ADLEN Bit = 0	8 mA	4%
ADC Right Channel	ADREN Bit = 0	8 mA	4%
ADC Left and Right Channels	ADLEN, ADREN Bits = 0	38 mA	17%
DAC2 (Left and Right Channels)	DA2EN Bit = 0	30 mA	15%
DAC1 (Left and Right Channels)	DA1EN Bit = 0	24 mA	12%
DAC2 AND DAC1 (Left and Right Chs)	DA2EN, DA1EN Bits = 0	60 mA	30%
ADC and DAC2 and DAC1	ADLEN, ADREN, DA2EN, DA1EN Bits = 0	108 mA	54%
Analog Channel	ANAEN Bit = 0	54 mA	27%
All Control Register 27	HPEN, DDMEN, AAMEN, ADLEN, ADREN, DA2EN, DA1EN, ANAEN Bits = 0	134 mA	67%
Converter	PDNI Bit = 1	140 mA	70%
All of the Above (Register 27 and Clocks and PDNI)	ENCLKO, ENBT3, ENBT2, ENBT1, ENCV3, ENCV2, ENCV1, C1EN, C2EN, C3EN, HPEN, DDMEN, AAMEN, ADLEN, ADREN, DA2EN, DA1EN, ANAEN Bits = 0, PDNI Bit = 1	176 mA	88%

AD1843

dependent; depending upon the sequence in which the hardware resources are powered down, the savings may be more or less than the typical numbers given.

Mode Changing

In general, there are very few restrictions with respect to changing the operating mode of the AD1843. Because of the advanced Continuous Time Oversampling technology, the waiting period associated with changes to the sample rate of the data converters (“Mode Change Enable” resynchronization delay) is eliminated. The only waiting periods associated with the AD1843 occur at start-up, and are documented in the “START-UP SEQUENCE” section below. Following the start-up sequence, the sample rate of the four data conversion resources on the AD1843 may be changed at any time, on-the-fly (presuming that they are enabled). All gain, mute and attenuation settings of enabled resources may also be changed at any time.

Channel Synchronization

If multiple AD1843s are used in a daisy-chained system, and it is desired to synchronize data conversion activity among the multiple codecs, the clock generator blocks of the AD1843s must be enabled on the same frame (see step 5 in the “START-UP SEQUENCE” section below).

A DAC channel does not actually start processing samples until the first rising edge of the conversion clock (CONV pin) after the sixth rising edge of frame sync (SDFS pin) after the channel is enabled (via a write to DA1EN or DA2EN in Control Register Address 27). The wait until the sixth rising edge of frame sync is necessary to allow the four deep DAC FIFO to be filled before conversion commences. The subsequent wait until the rising edge of the conversion clock is necessary to synchronize the serial interface based DAC channel enable command with a conversion clock that is potentially already running (which is particularly likely if the SYNC pin inputs and lock mode are in use).

The ADC channels behave very similarly to the DAC channels. An ADC channel does not actually start taking samples until the first rising edge of the conversion clock (CONV pin) after the sixth rising edge of frame sync (SDFS pin) after the channel is enabled (via a write to ADLEN or ADREN in Control Register Address 27). The wait until the sixth rising edge of frame sync is present so that the ADC startup is similar to that of the DAC startup, as well as to allow some time for stale ADC data inside the AD1843 to be cleared. The subsequent wait until the rising edge of the conversion clock is necessary to synchronize the serial interface based ADC channel enable command with a conversion clock that it potentially already running (which is particularly likely if the SYNC pin inputs and lock mode are in use).

Supported Conversion Rates

With all conversion channels operating (i.e., ADC left, ADC right, DAC1 and DAC2), the AD1843 is able to support sampling rates up to 49 kHz, which 2.1% higher than the nominal maximum audio standard of 48 kHz, to accommodate timebase drift while configured in slave mode. If either one DAC (i.e., either DAC1 or DAC2) or both ADC channels (i.e., ADC left and ADC right) are shut down, then the AD1843 can support sampling up to 54 kHz on all channels of the remaining conver-

sion resources, as long as the DFREE bit (Control Register Address 27) is asserted (i.e., set to “1”). If DFREE is not asserted, then the maximum sampling rate for the remaining conversion resources is 49 kHz.

Digital Filter Selection

The operative digital filter modes for the four conversion resources on the AD1843 SoundComm are programmed using Control Register Address 25. ADLFLT (Bit 0) selects the digital filter mode for the ADC left channel and ADRFLT (Bit 1) selects the digital filter mode for the ADC right channel. Note that these bits also establish the full-scale input voltage range for these channels as well. DA1FLT (Bit 8) selects the DAC1 digital filter mode, and DA2FLT (Bit 9) selects the DAC2 digital filter mode. Note that these bits also establish the full-scale output voltage for these channels as well.

The three digital filter modes are audio, modem and resampler. The specifications for these modes are given in the description of Control Register Address 25, as well as in the “SPECIFICATIONS” section of this data sheet. The specifications have been made to satisfy the demands of the applications which the AD1843 can serve. The audio mode provides decimation and interpolation characteristics sufficient for high quality capture and playback of material from 20 Hz to 20 kHz. The modem mode provides characteristics sufficient for modulation standards up to V.34 quality. The resampling mode provides optimal characteristics for high quality sample rate conversion. While in the resampling mode, all images in the resampled data stream (including those in the transition band) are attenuated to below the quantization noise floor. Note that the maximum sample rate for modem mode is 24 kHz.

Digital Resampling

Digital resampling is best achieved by routing the digital output of one of the DACs back to the digital input of one of the ADCs. This bypasses the analog portion of the DAC and ADC, eliminating their noise and signal delay contributions. This feature is enabled by bits DAADR1:0 (Digital ADC Right Channel Source Select) and DAADL1:0 (Digital ADC Left Channel Source Select) in Control Register Address 25.

If the “Digital Resampler Filter Mode” (DRSFLT bit = “1,” Control Register Address 25) is enabled, the DAC2 pair is sacrificed, but the remaining four channels (ADC left and right, DAC1 left and right) can still be used in any way they could have been when not in “Digital Resampler Filter Mode.” When in this mode, internal AD1843 hardware normally devoted to DAC2 is reallocated to the other four channels, allowing these channels to realize superior digital filtering. Note that the AD1843 DOES NOT actually have to be in digital resampler filter mode to perform digital resampling, however the superior digital filters in this mode allow for a much higher quality digital resampling.

Using the AD1843 in a Modem Application

The AD1843 analog performance is sufficient to support the modem Analog Front End (AFE) function, for data modulation standards up to and including the 28.8 kbps V.34 ITU standard. The data pump function is performed in a companion DSP, such as the ADSP-2181, for which several V.34 algorithms (from third party Independent Algorithm Vendors) exist.

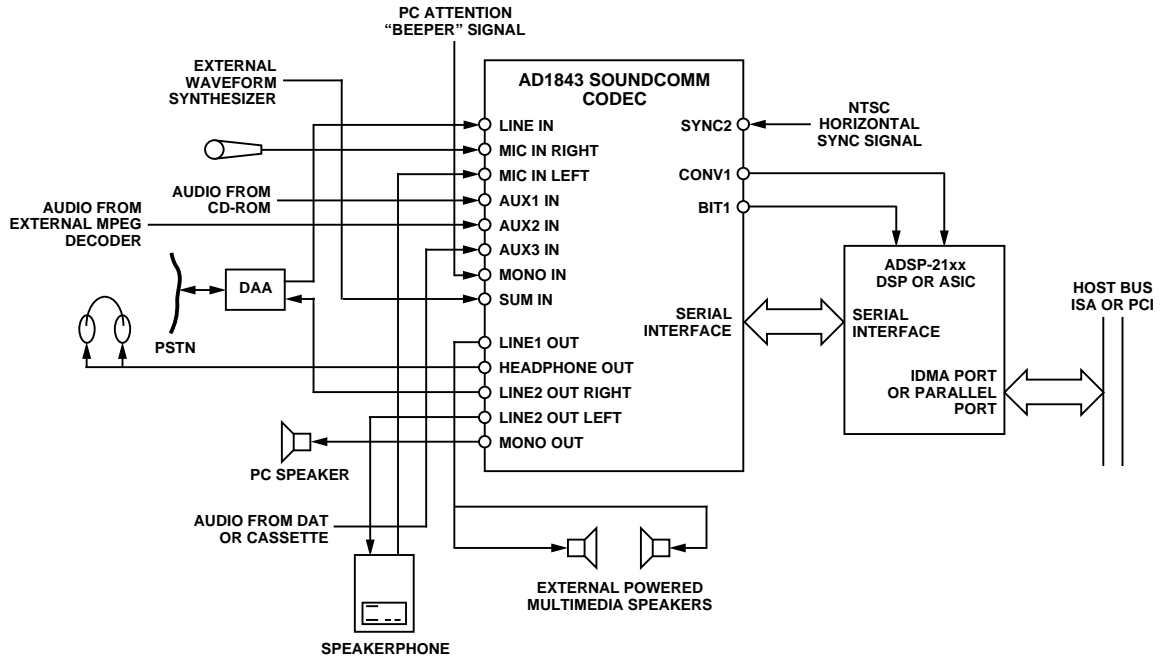

Figure 6. Typical Configurations

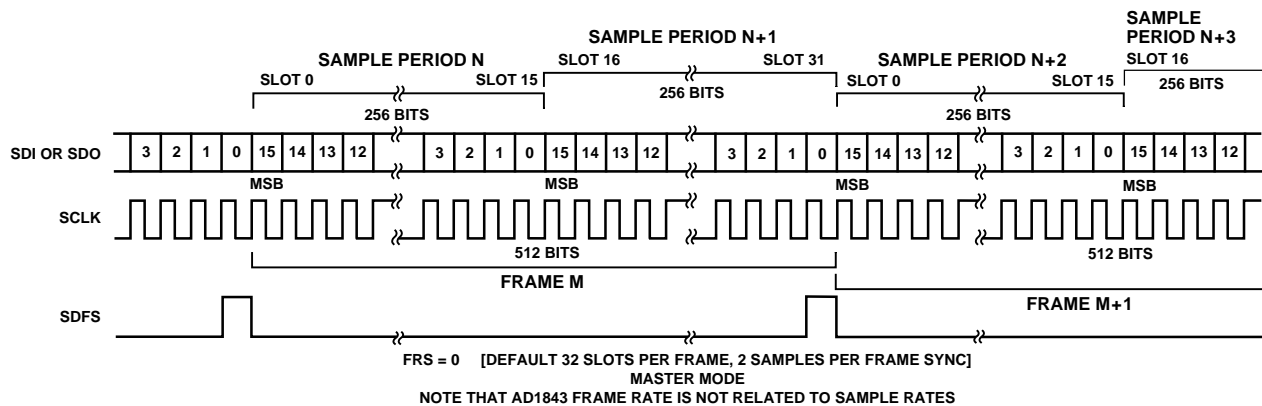

Figure 7. FRS = 0, Master Mode Timing

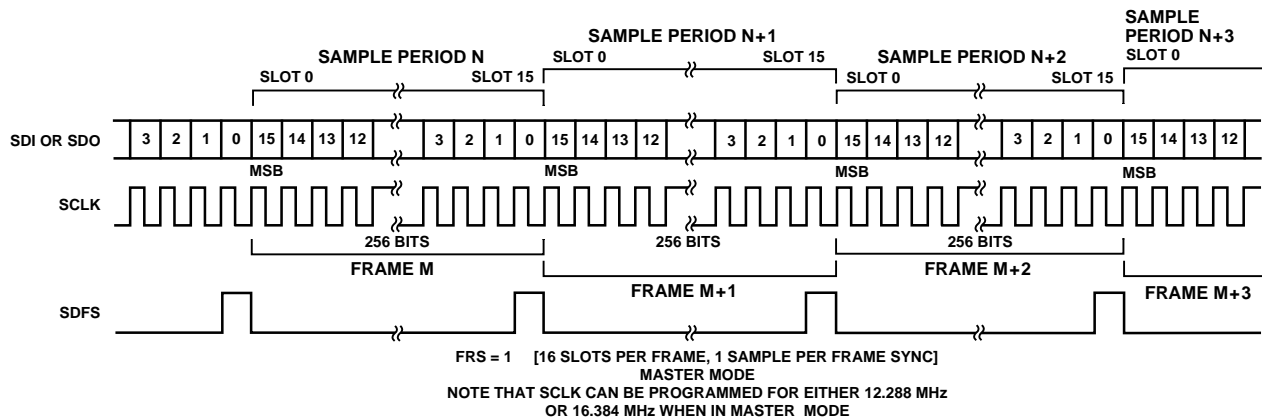

Figure 8. FRS = 1, Master Mode Timing

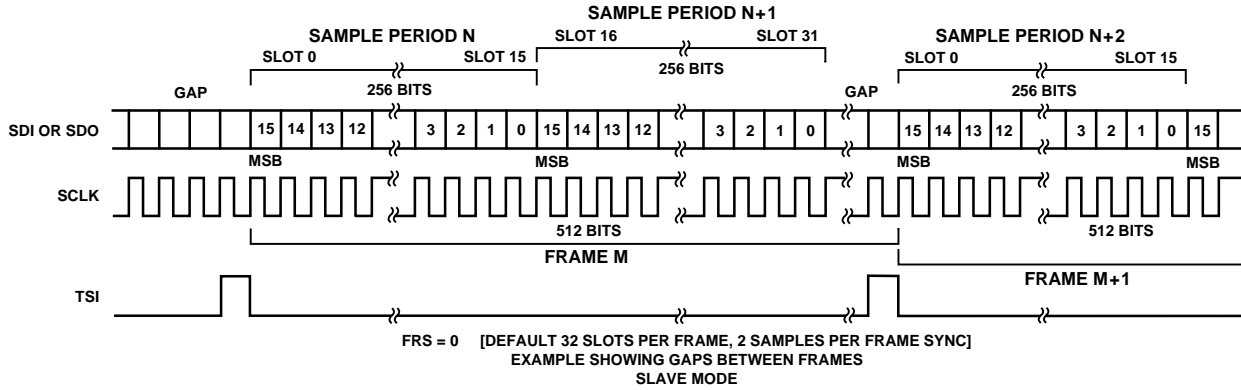

Figure 9a. FRS = 0, Slave Mode Timing

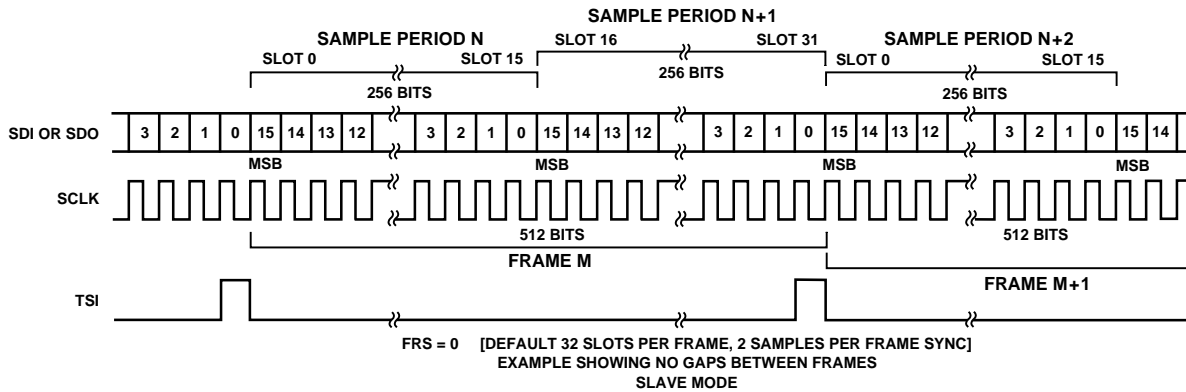

Figure 9b. FRS = 0, Slave Mode Timing

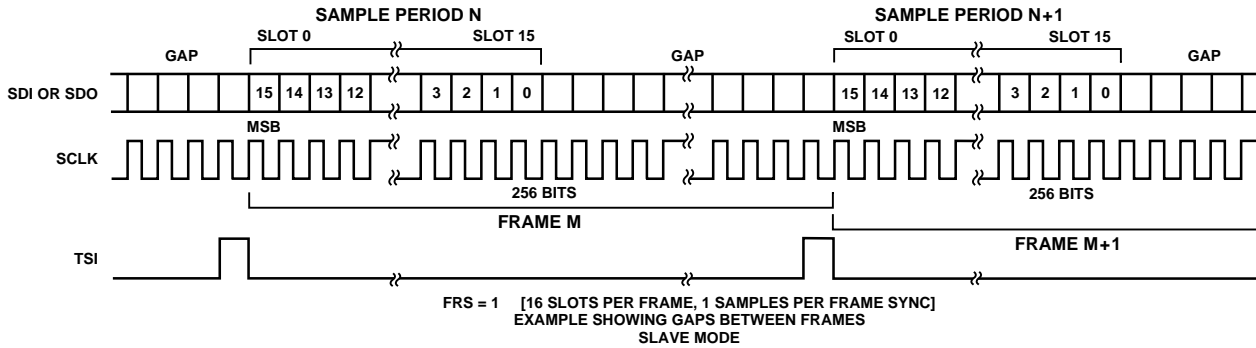

Figure 10a. FRS = 1, Slave Mode Timing

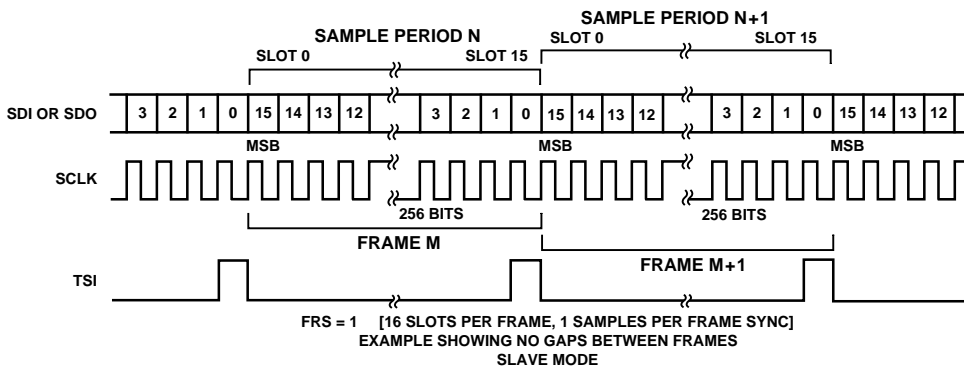

Figure 10b. FRS = 1, Slave Mode Timing

Modem Data Access Arrangement (DAA) devices are generally differential on the transmit side, and single-ended on the receive side. The DAA transmit input (generally differential) should be connected to the DAC2 output, pins LOUT2LP and LOUT2LN, or LOUT2RP and LOUT2RN. The DAA receive output (generally single-ended) should be connected to one of the ADC line inputs, LINLP or LINRP. See the “APPLICATION CIRCUITS” section below for more detail on the electrical connections. There are several software driver steps that are required to configure the SoundComm codec for use as a modem AFE.

Configure DAC2

1. Set the DA2FLT bit (Control Register Address 25, Bit 9) to “1,” to select the digital modem filter mode. The DAC2 outputs can be used either as differential outputs or single-ended outputs depending on how the pins are connected electrically; no Control Register writes are required to configure the DAC2 outputs as either differential or single-ended.
2. Program LDA2G5:0 (Control Register Address 10, Bits 8 through 13) to “00 0101” (i.e., +4.5 dB) or RDA2G5:0 (Control Register 10, Bits 0 through 5) to “00 0101” (i.e., +4.5 dB), depending on whether the DAA transmit input is connected to the left channel DAC2 output (use LDA2G5:0) or the right channel DAC2 output (use RDA2G5:0). This code establishes the DAC2 nominal analog output swing at 3.156 V p-p single-ended, or 6.312 V p-p differentially. The 3.156 V p-p level is equivalent to 3.17 dBm.

Configure ADC

1. Set the ADLFLT bit (Control Register Address 25, Bit 0) to “1,” or the ADRFLT bit (Control Register Address 25, Bit 1) to “1,” to select the digital modem filter mode. Set ADLFLT if the DAA receive output is connected to the AD1843 LINLP input; set ADRFLT if the DAA receive output is connected to the AD1843 LINRP input. Set the LINLSD bit (Control Register Address 28, Bit 0) to “1” if the DAA is connected to the AD1843 LINLP input; set the LINRSD bit (Control Register Address 28, Bit 1) to “1” if the DAA is connected to the AD1843 LINRP input.
2. Program LIG3:0 (Control Register Address 2, Bits 8 through 11) to “0000” (i.e., 0.0 dB) or RIG3:0 (Control Register Address 2, Bits 0 through 3) to “0000” (i.e., 0.0 dB) depending on whether the left or right ADC input channel is being used for the modem function. This code maps an analog input swing of 3.156 V p-p to the full dynamic range of the 16-bit digital sample (i.e., $\pm 2^{15}$). The 3.156 V p-p level is equivalent to 3.17 dBm.

Note that if the AD1843 is to be reconfigured dynamically, the affected converter must be powered down before its associated digital filter can be changed. In other words, if the digital filter for the ADC left channel is being changed from audio mode to modem mode, the ADC left channel must be powered down first (using the ADLEN bit in Control Register Address 27).

Use the ADREN bit in Control Register Address 27 for the ADC right channel, the DAC1EN bit in Control Register Address 27 for DAC1, and the DAC2EN bit in Control Register Address 27 for DAC2.

Typical Configurations

Figure 6 below illustrates example connections between the AD1843 SoundComm codec and other system resources. The rich analog input and output connectivity of the AD1843 allows a wide variety of configuration possibilities. Note that the level of modem, speakerphone and external speaker concurrency is application and DSP resource dependent.

SERIAL INTERFACE

The AD1843 SoundComm Codec transmits and receives both data and control/status information through its serial port.

The AD1843 can be configured as either master or slave of the serial interface. This is selected by using the BM pin. When BM is tied HI, the AD1843 serves as bus master and supplies the frame sync and the serial clock. When BM is tied LO, the AD1843 serves as bus slave and receives the frame sync and the serial clock. The level on BM should not be altered unless the reset pin (RESET) is asserted.

The AD1843 has six pins devoted to the serial interface: SDI, SDO, SCLK, SDFS, TSI and TSO. The SDI pin is for serial data input to the AD1843 and the SDO pin is for serial data output from the AD1843. The SCLK pin is the serial interface clock. Communication in and out of the AD1843 requires bits of data to be transmitted after a rising edge of SCLK, and sampled on a falling edge of SCLK. When the AD1843 is bus master (BM pin tied HI), the SCLK frequency driven by the AD1843 will be 12.288 MHz by default, but this can be increased to 16.384 MHz by setting the SCF bit in Control Register 26. When the AD1843 is bus slave (BM pin tied LO), the SCLK frequency driven to the AD1843 may be as high as 24.576 MHz, but must not be any higher than the frequency on the XTALI pin.

The SDFS pin is for the serial interface frame sync. When bus master, new frames are marked by a HI pulse driven out on SDFS one serial clock period before the frame begins. When bus slave, new frames must be marked by a LO to HI transition driven in on SDFS one serial clock period before the frame begins, but the transition back from HI to LO may occur at any time provided the HI and LO times of SDFS are at least one SCLK period in duration each.

When the AD1843 is bus master, frame size is controlled by the FRS bit in Control Register 26. When FRS is set to “1,” each frame is divided into 16 slots of 16 bits. When FRS is reset to “0,” each frame is divided into 32 slots of 16 bits. In 32 slot configuration, the second 16 slots of a frame must have slot assignments that are identical to the first 16 slots of the frame; 32 slot configuration is essentially 16 slot configuration with every other SDFS pulse missing. Although these are the frame sizes

AD1843

produced by an AD1843 serving as bus master, an AD1843 serving as bus slave does not actually require these frame sizes. When FRS is set to “1,” a slave will operate correctly with any number or fraction of slots, provided there are enough slots for it to complete its necessary communication (see below). When FRS is reset to “0,” a slave can also operate correctly with a wide range in the number of slots per frame, however it will automatically retake ownership of the serial interface bus 16 slots after it is first given ownership of the bus in a frame.

The nominal minimum number of slots when the AD1843 is configured in slave mode is six. The codec must be supplied with at least $6 \times 16 = 96$ SCLK periods (both rising and falling edges); SCLK may be gated (i.e., no need to be continuous) between valid slots.

While SDFS marks the beginning of frames, AD1843 bus ownership during a frame is controlled by the TSI (Time Slot In) and TSO (Time Slot Out) pins. When bus slave, a level HI on TSI grants the AD1843 bus ownership beginning with the next SCLK period. The TSI pin is monitored only when an AD1843 does not already own the bus; once an AD1843 is given ownership of the bus, the level on TSI is ignored until one SCLK period before bus ownership is relinquished. Bus ownership will last for six slots. Coincident with the final SCLK period of the final slot owned, the AD1843 asserts TSO HI. This allows chaining of AD1843s onto a common serial bus by connecting the TSO pin of one AD1843 to the TSI pin on the next later AD1843 in a chain. In single codec systems where the SoundComm is configured as bus slave, connect the AD1843 SDFS and TSI signals together. When an AD1843 is bus master, its function is identical to that just described for the slave, except a bus master always owns the first six slots and its TSI pin is ignored (but should be tied LO).

Whenever an AD1843 does not own the bus, its SDO pin will be three-stated and its SDI pin is ignored. Figures 7 through 10 illustrate the signal, slot, sample and frame relationships for the four basic operating modes of the AD1843 serial interface.

The AD1843 requires slots of communication each time it takes ownership of the serial bus. The first slot is used for a Control Word input and a Status Word output. The second slot is used

for Control Register write data input and read data output. The remaining slots are used for playback (DAC) data input and capture (ADC) data output, where each channel has an assigned slot. Table II and Figure 11 illustrate these slot assignments.

Since the conversion channels of the AD1843 can be programmed to run at different sample rates, a communication mechanism indicates when playback channels request data, when playback data is actually sent to the AD1843, and when transmission of capture data from the AD1843 becomes necessary. This is facilitated by the Control and Status Words located in the first slot. The Control Word indicates which slots in the current frame contain valid playback data. The Status Word indicates if playback data can be sent to the AD1843 during the next frame, and which slots in the current frame contain valid capture data. See the descriptions of the Control Word and the Status Word below for additional detail.

Four word FIFO buffers are used on the inputs of each of the DACs to allow data to be transferred in small bursts. This reduces the required response time to playback data requests, and also buffers differences between the frame sync rate and the channel sample rate. The Status Word indicates that playback data can be sent if there is any room in the buffers, thus tending to keep the input buffers full. Underrun flags are available in Control Register 1, which indicate if an input buffer ran out of data. If an underrun occurs, a zero is used in place of the unavailable data. To ensure underruns do not occur, playback data must be sent to the AD1843 within two sample periods after the status word indicates that the DAC FIFO is not full.

Note that the DAC Not Full status bits (DA2RQ and DA1RQ in the Status Word Output) are updated immediately (i.e., in the same frame as a valid write to the DAC FIFOs). If the DAC Input Valid Flags (DA2V and DA1V in the Control Word Input) are set (i.e., DAC data is valid) and only one location in the DAC1 and DAC2 input FIFOs is available, then the DA2RQ and DA1RQ status bits will reflect this valid write, and will be reset to “0.” This is possible because the DA2V and DA1V bits are in the most significant bits of the Control Word and the DA2RQ and DA1RQ bits are in the least significant bits of the Status Word, and the AD1843 uses this intervening time

Table II. AD1843 Slot Assignment

32 Slot Mode (FRS Reset to “0”)

Slot	SDI Pin	SDO Pin
0 & 16	Control Word Input	Status Word Output
1 & 17	Control Register Data Input	Control Register Data Output
2 & 18	Playback Data Input—DAC1 Left	Capture Data Output—ADC Left
3 & 19	Playback Data Input—DAC1 Right	Capture Data Output—ADC Right
4 & 20	Playback Data Input—DAC2 Left	Reserved (Unused)
5 & 21	Playback Data Input—DAC2 Right	Reserved (Unused)

16 Slot Mode (FRS Set to “1”)

Slot	SDI Pin	SDO Pin
0	Control Word Input	Status Word Output
1	Control Register Data Input	Control Register Data Output
2	Playback Data Input—DAC1 Left	Capture Data Output—ADC Left
3	Playback Data Input—DAC1 Right	Capture Data Output—ADC Right
4	Playback Data Input—DAC2 Left	Reserved (Unused)
5	Playback Data Input—DAC2 Right	Reserved (Unused)

interval to update the DAC Not Full status bits. Therefore driver software does not have to make provision for frame-to-frame delays between control and status information; the information in each frame is always up to date.

The AD1843 supports locking to an external clock which may result in a sample rate that is marginally higher than the nominal audio standard maximum sample rate of 48 kHz. This is necessary since two crystal-based clock sources are never *perfectly* matched to one another. One is always at a slightly higher frequency. The AD1843 conversion channels have been designed to support sample rates that are up to 2.1% higher than 48 kHz (i.e., 49 kHz), referenced to the AD1843's clock input on XTALI, when all conversion channels are simultaneously running. Even higher rates can be supported when all channels are not running simultaneously. See the "Conversion Rates" section above for additional details. The serial interface must also allow for this higher sample rate with a frame sync (SDFS) rate that is at least as high as the sample rate in 16 slot per frame

mode, or half as high as the sample rate in 32 slot per frame mode. When the AD1843 is bus master, the SCLK frequency is either 12.288 MHz or 16.384 MHz, which allows for up to 48 kHz or 64 kHz sampling rates, respectively.

The AD1843 Control Registers are read and written by transmitting a read/write request bit along with the Control Register address in the slot 0 Control Word. When a read is requested, the contents of the Control Register addressed is transmitted out during slot 1 of the following frame. When a write is requested, data to be written must be transmitted to the AD1843 in slot 1, and the former contents of the control register are transmitted out during slot 1 of the following frame. Unless otherwise noted, Control Register writes do not take effect until the current round of six communication TDM time slots concludes. Equivalently, unless otherwise noted, Control Register writes do not take effect until the subsequent falling edge of the TSO signal.

The following sections describe the bit assignments for all time slots.

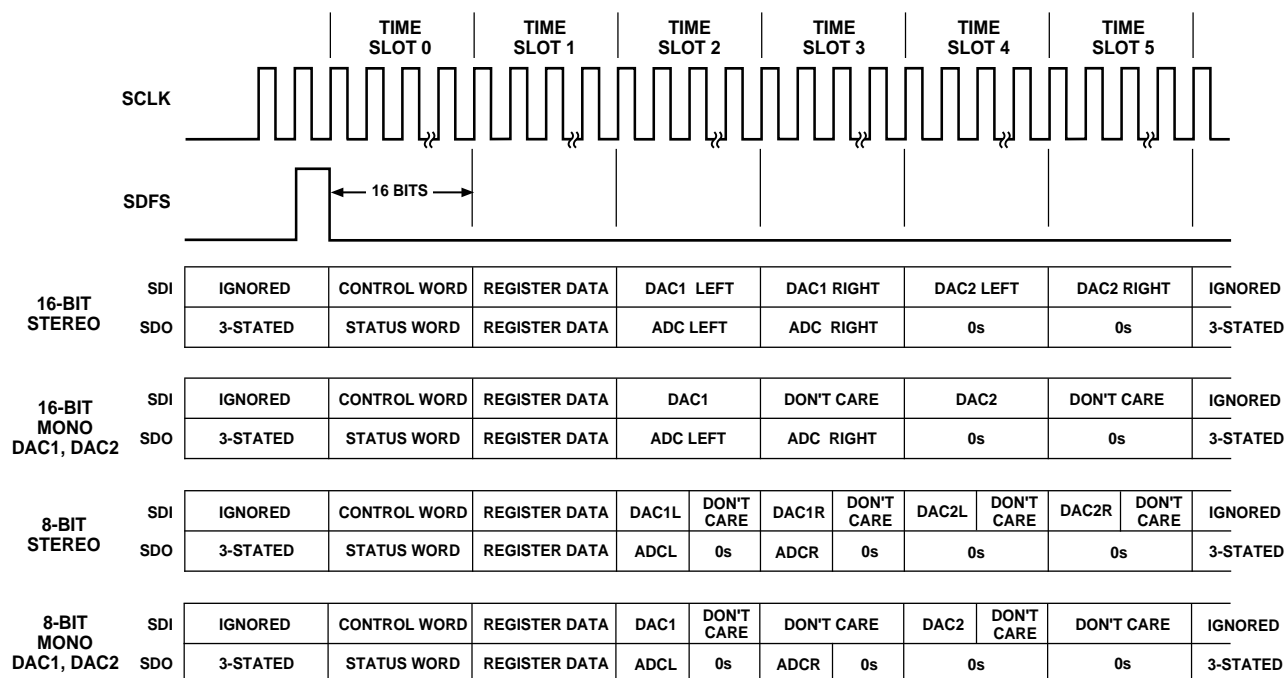

THE DIAGRAM ABOVE IS INTENDED TO BE ILLUSTRATIVE OF THE MORE COMMONLY USED CONFIGURATIONS. ADC LEFT, ADC RIGHT, DAC1 AND DAC2 CAN BE INDIVIDUALLY ASSIGNED TO 8-BIT OR 16-BIT SAMPLE WIDTH, AND DAC1 AND DAC2 CAN BE INDIVIDUALLY ASSIGNED TO STEREO OR MONO MODE. EACH AD1843 CONSUMES 6 TMD SLOTS (REQUIRING 96 SCLK PERIODS), LEAVING 10 TDM SLOTS UNUSED IN A 16 SLOT FRAME.

NOTE THAT BECAUSE THE SERIAL INTERFACE AND THE ADC AND DACS ARE IN GENERAL ASYNCHRONOUS, NOT EVERY CAPTURE OR PLAYBACK TIME SLOT WILL CONTAIN VALID DATA. THE HOST PROCESSOR MUST POLL THE STATUS WORD TO DETERMINE WHETHER THE ADC DATA IS VALID AND WHETHER THE DAC IS REQUESTING ADDITIONAL SAMPLES.

Figure 11. AD1843 Slot Assignments

AD1843

SERIAL INTERFACE INPUT

Note that the references to slot numbers are valid only when the AD1843 is configured in master mode. For slave mode, bus ownership does not necessarily start on Slot 0.

Control Word Input (Slot 0 or 16)							
Data 15	Data 14	Data 13	Data 12	Data 11	Data 10	Data 9	Data 8
res	res	res	res	res	res	DA2V	DA1V
Data 7	Data 6	Data 5	Data 4	Data 3	Data 2	Data 1	Data 0
R/W	res	res	IA4	IA3	IA2	IA1	IA0

- DA2V** DAC2 Input Valid Flag. When in DAC2 stereo mode, setting this bit to “1” indicates that slots 4 and 5 contain valid playback data for the left and right channels of DAC2, respectively. When in DAC2 mono mode, setting this bit to “1” indicates that slot 4 contains valid playback data for both left and right channels of DAC2. Slot 5 is ignored in DAC2 mono mode. When this bit is reset to “0,” data in slots 4 and 5 is ignored. This bit is ignored if the AD1843 did not request data for DAC2 in the last frame (see the DA2RQ bit in the Status Word Output).
- DA1V** DAC1 Input Valid Flag. When in DAC1 stereo mode, setting this bit to “1” indicates that slots 2 and 3 contain valid playback data for the left and right channels of DAC1, respectively. When in DAC1 mono mode, setting this bit to “1” indicates that slot 2 contains valid playback data for both left and right channels of DAC1. Slot 3 is ignored in DAC1 mono mode. When this bit is reset to “0,” data in slots 2 and 3 is ignored. This bit is ignored if the AD1843 did not request data for DAC1 in the last frame (see the DA1RQ bit in the Status Word Output).
- R/W** Read/Write Request. Either a read from or a write to a Control Register occurs every frame. Setting this bit to “1” indicates a Control Register read while resetting this bit to “0” initiates a Control Register write. Bits IA4:0 define the Control Register address. When reading, the contents of the Control Register addressed are transmitted during slot 1 of the following frame. When writing, the data to be written is taken from slot 1 and the former contents of the Control Register are transmitted during slot 1 of the following frame.
- IA4:0** Control Register address for read or write.
- res** Reserved for future expansion. To ensure future compatibility, write “0” to all reserved bits.

Control Register Write Data Input (Slot 1 or 17)							
Data 15	Data 14	Data 13	Data 12	Data 11	Data 10	Data 9	Data 8
DATA15	DATA14	DATA13	DATA12	DATA11	DATA10	DATA9	DATA8
Data 7	Data 6	Data 5	Data 4	Data 3	Data 2	Data 1	Data 0
DATA7	DATA6	DATA5	DATA4	DATA3	DATA2	DATA1	DATA0

Format for the input data to written to the addressed Control Register. MSB is first.

DAC1 Left Sample Input (Slot 2 or 18)							
Data 15	Data 14	Data 13	Data 12	Data 11	Data 10	Data 9	Data 8
DATA15	DATA14	DATA13	DATA12	DATA11	DATA10	DATA9	DATA8
Data 7	Data 6	Data 5	Data 4	Data 3	Data 2	Data 1	Data 0
DATA7	DATA6	DATA5	DATA4	DATA3	DATA2	DATA1	DATA0

Data format may be 8-bit unsigned linear PCM, 16-bit signed linear PCM, 8-bit μ -Law companded, or 8-bit A-Law companded. MSB is first. DATA7:0 are ignored in 8-bit linear or 8-bit companded modes.

DAC1 Right Sample Input (Slot 3 or 19)

Data 15	Data 14	Data 13	Data 12	Data 11	Data 10	Data 9	Data 8
DATA15	DATA14	DATA13	DATA12	DATA11	DATA10	DATA9	DATA8
Data 7	Data 6	Data 5	Data 4	Data 3	Data 2	Data 1	Data 0
DATA7	DATA6	DATA5	DATA4	DATA3	DATA2	DATA1	DATA0

Data format may be 8-bit unsigned linear PCM, 16-bit signed linear PCM, 8-bit μ -Law companded, or 8-bit A-Law companded. MSB is first. DATA7:0 are ignored in 8-bit linear or 8-bit companded modes.

DAC2 Left Sample Input (Slot 4 or 20)

Data 15	Data 14	Data 13	Data 12	Data 11	Data 10	Data 9	Data 8
DATA15	DATA14	DATA13	DATA12	DATA11	DATA10	DATA9	DATA8
Data 7	Data 6	Data 5	Data 4	Data 3	Data 2	Data 1	Data 0
DATA7	DATA6	DATA5	DATA4	DATA3	DATA2	DATA1	DATA0

Data format may be 8-bit unsigned linear PCM, 16-bit signed linear PCM, 8-bit μ -Law companded, or 8-bit A-Law companded. MSB is first. DATA7:0 are ignored in 8-bit linear or 8-bit companded modes.

DAC2 Right Sample Input (Slot 5 or 21)

Data 15	Data 14	Data 13	Data 12	Data 11	Data 10	Data 9	Data 8
DATA15	DATA14	DATA13	DATA12	DATA11	DATA10	DATA9	DATA8
Data 7	Data 6	Data 5	Data 4	Data 3	Data 2	Data 1	Data 0
DATA7	DATA6	DATA5	DATA4	DATA3	DATA2	DATA1	DATA0

Data format may be 8-bit unsigned linear PCM, 16-bit signed linear PCM, 8-bit μ -Law companded, or 8-bit A-Law companded. MSB is first. DATA7:0 are ignored in 8-bit linear or 8-bit companded modes.

AD1843

SERIAL INTERFACE OUTPUT

Status Word Output (Slot 0 or 16)							
Data 15	Data 14	Data 13	Data 12	Data 11	Data 10	Data 9	Data 8
res	res	res	res	res	res	ADRV	ADLV
Data 7	Data 6	Data 5	Data 4	Data 3	Data 2	Data 1	Data 0
res	res	res	res	res	res	DA2RQ	DA1RQ

ADRV Right ADC Channel Output Valid Flag. Set to “1” if slot 3 (or 19) contains valid right ADC capture data.

ADLV Left ADC Channel Output Valid Flag. Set to “1” if slot 2 (or 18) contains valid left ADC capture data.

DA2RQ DAC2 Input Request Flag. Set to “1” if DAC2 is enabled and its four word stereo input buffer is not full.

DA1RQ DAC1 Input Request Flag. Set to “1” if DAC1 is enabled and its four word stereo input buffer is not full.

res Reserved for future expansion. Read back as “0.” Should be ignored to ensure future compatibility.

Control Register Data Output (Slots 1 or 17)							
Data 15	Data 14	Data 13	Data 12	Data 11	Data 10	Data 9	Data 8
DATA15	DATA14	DATA13	DATA12	DATA11	DATA10	DATA9	DATA8
Data 7	Data 6	Data 5	Data 4	Data 3	Data 2	Data 1	Data 0
DATA7	DATA6	DATA5	DATA4	DATA3	DATA2	DATA1	DATA0

Contents of Control Register addressed in previous frame.

ADC Left Sample Output (Slots 2 or 18)							
Data 15	Data 14	Data 13	Data 12	Data 11	Data 10	Data 9	Data 8
DATA15	DATA14	DATA13	DATA12	DATA11	DATA10	DATA9	DATA8
Data 7	Data 6	Data 5	Data 4	Data 3	Data 2	Data 1	Data 0
DATA7	DATA6	DATA5	DATA4	DATA3	DATA2	DATA1	DATA0

Data format may be 8-bit unsigned linear PCM, 16-bit signed linear PCM, 8-bit μ -Law companded, or 8-bit A-Law companded. MSB is first. DATA7:0 are ignored in 8-bit linear or 8-bit companded modes.

ADC Right Sample Output (Slots 3 or 19)							
Data 15	Data 14	Data 13	Data 12	Data 11	Data 10	Data 9	Data 8
DATA15	DATA14	DATA13	DATA12	DATA11	DATA10	DATA9	DATA8
Data 7	Data 6	Data 5	Data 4	Data 3	Data 2	Data 1	Data 0
DATA7	DATA6	DATA5	DATA4	DATA3	DATA2	DATA1	DATA0

Data format may be 8-bit unsigned linear PCM, 16-bit signed linear PCM, 8-bit μ -Law companded, or 8-bit A-Law companded. MSB is first. DATA7:0 are ignored in 8-bit linear or 8-bit companded modes.

Reserved Output (Slots 4 or 20)

Data 15	Data 14	Data 13	Data 12	Data 11	Data 10	Data 9	Data 8
res	res	res	res	res	res	res	res
Data 7	Data 6	Data 5	Data 4	Data 3	Data 2	Data 1	Data 0
res	res	res	res	res	res	res	res

res Reserved for future expansion. Read back as “0.” Should be ignored to ensure future compatibility.

Reserved Output (Slots 5 or 21)

Data 15	Data 14	Data 13	Data 12	Data 11	Data 10	Data 9	Data 8
res	res	res	res	res	res	res	res
Data 7	Data 6	Data 5	Data 4	Data 3	Data 2	Data 1	Data 0
res	res	res	res	res	res	res	res

res Reserved for future expansion. Read back as “0.” Should be ignored to ensure future compatibility.

CONTROL REGISTERS**Control Register Architecture**

All Control Registers are cleared to their default state when either the $\overline{\text{RESET}}$ pin or the $\overline{\text{PWRDWN}}$ pin is asserted. All conversion related Control Registers (Addresses 1–15, 25 and 27) are cleared to defaults when the conversion resources of the AD1843 are powered down through the PDNI bit in Control Register Address 28. Control Registers which manage analog DAC gain/attenuation (Addresses 3–10) are cleared to defaults whenever the resource they manage is powered down. Finally, the three clock generator sample phase shift Control Registers (Addresses 18, 21 and 24) are cleared to defaults whenever their associated clock generator is powered down. Writes to Control Registers are blocked until a clearing condition no longer exists. Writes to Control Registers are also blocked immediately after the $\overline{\text{RESET}}$ pin or the $\overline{\text{PWRDWN}}$ pin is asserted until the AD1843’s internal clocks have settled, which is indicated by the INIT bit in Control Register Address 0. Control Registers may always be read.

Figures 12 and 13 associate the Control Registers to the AD1843 Block Diagram.

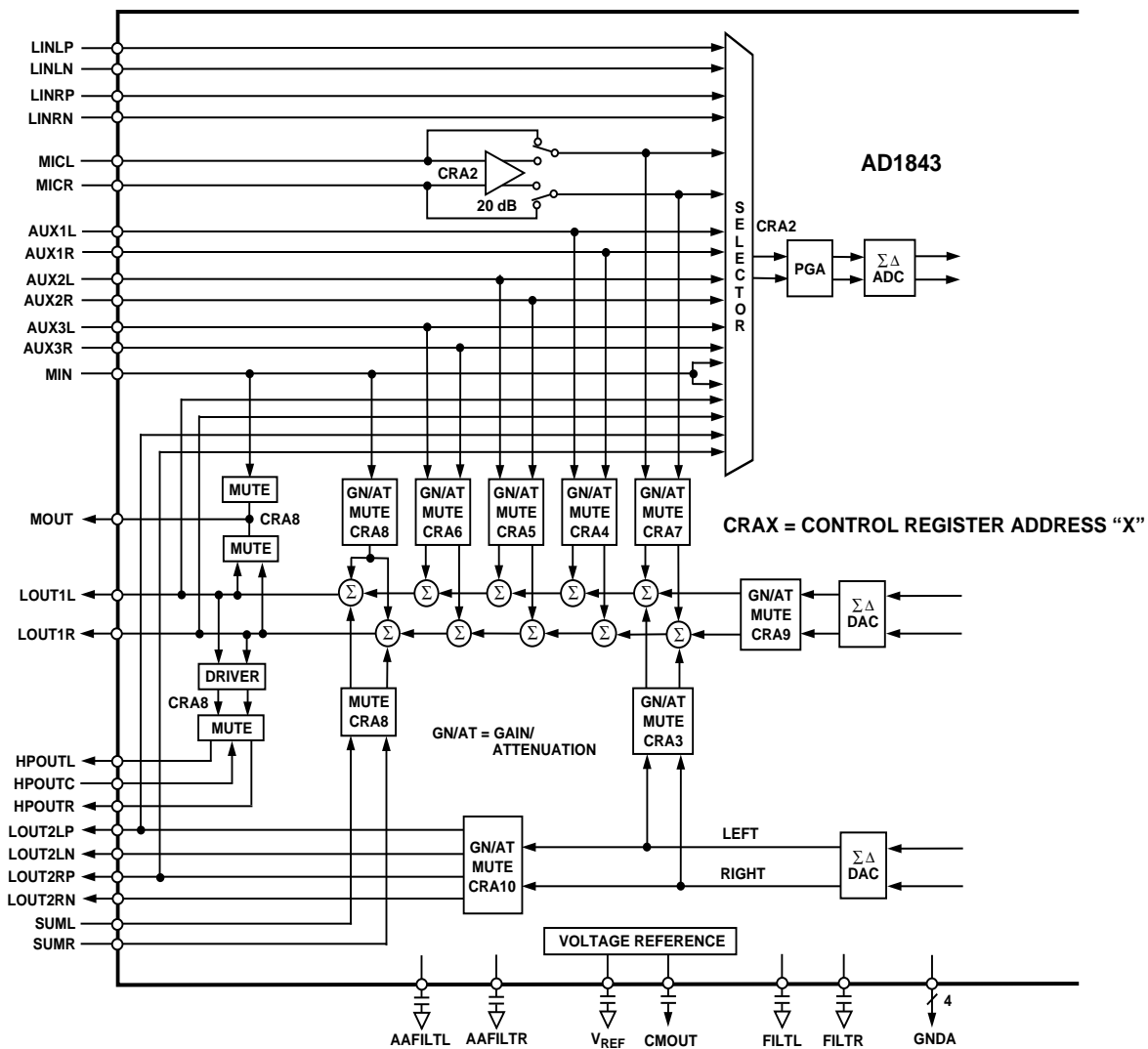

Figure 12. AD1843 Control Registers Associated with Block Diagram

Address	Register Description
0	Codec Status and Revision Identification (Read Only)
1	Channel Status Flags
2	Input Control—ADC Source and Gain/Attenuation
3	Mix Control—DAC2 to Mixer
4	Mix Control—Auxiliary 1 to Mixer
5	Mix Control—Auxiliary 2 to Mixer
6	Mix Control—Auxiliary 3 to Mixer
7	Mix Control—Mic to Mixer
8	Mix/Misc. Control—Mono In to Mixer and Miscellaneous Settings
9	Output Control—DAC1 Analog Gain/Attenuation
10	Output Control—DAC2 Analog Gain/Attenuation
11	Output Control—DAC1 Digital Attenuation
12	Output Control—DAC2 Digital Attenuation
13	Digital Mix Control—ADC to DAC1
14	Digital Mix Control—ADC to DAC2
15	Codec Configuration—Channel Sample Rate Source Select

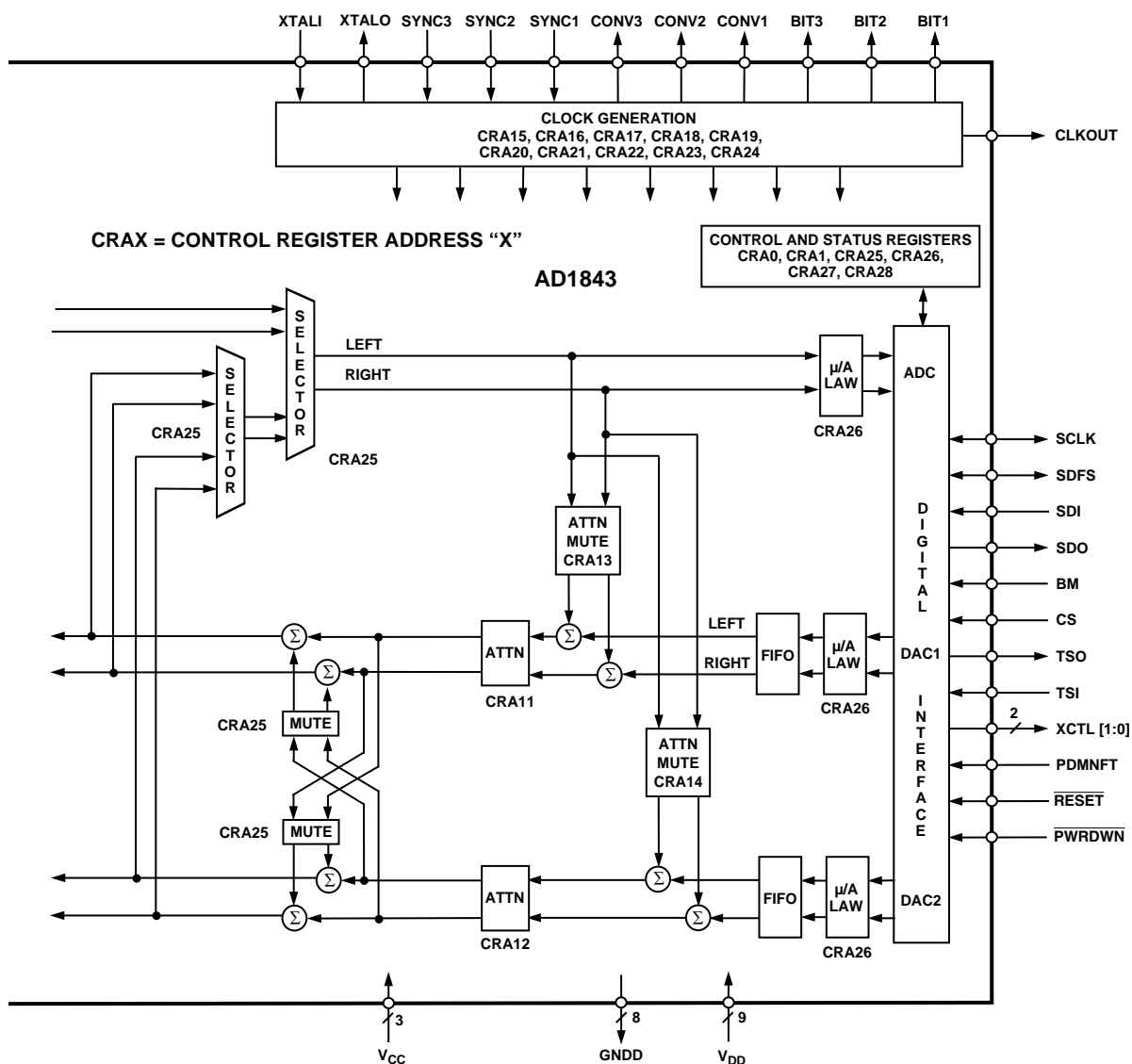

Figure 13. AD1843 Control Registers Associated with Block Diagram

Address	Register Description
16	Clock Generator 1 Control—Mode
17	Clock Generator 1 Control—Sample Rate
18	Clock Generator 1 Control—Sample Phase Shift
19	Clock Generator 2 Control—Mode
20	Clock Generator 2 Control—Sample Rate
21	Clock Generator 2 Control—Sample Phase Shift
22	Clock Generator 3 Control—Mode
23	Clock Generator 3 Control—Sample Rate
24	Clock Generator 3 Control—Sample Phase Shift
25	Codec Configuration—Digital Filter and Mode Select
26	Codec Configuration—Serial Interface
27	Codec Configuration—Channel Power Down
28	Codec Configuration—Fundamental Settings
29	Reserved for Future Expansion
30	Reserved for Future Expansion
31	Reserved for Future Expansion

AD1843

Address 0								Codec Status and Revision Identification							
Data 15		Data 14		Data 13		Data 12		Data 11		Data 10		Data 9		Data 8	
INIT		PDNO		res		res		res		res		res		res	
Data 7		Data 6		Data 5		Data 4		Data 3		Data 2		Data 1		Data 0	
res		res		res		res		ID3		ID2		ID1		ID0	

This register is read only.

INIT Clock Initialization Flag. This bit is set to “1” if the AD1843’s internal clocks generated from the crystal input pin XTALI have not yet stabilized. When set to “1,” Control Registers may be read if the AD1843 is configured as a Bus Slave (see the definition for the BM pin), but Control Register writes will be blocked. This bit is set to a “1” after the $\overline{\text{RESET}}$ pin is asserted, or when the power-down sequence (initiated by asserting the $\overline{\text{PWRDWN}}$ pin) has completed. The bit is reset to “0” usually within 400 to 800 μsec after the $\overline{\text{RESET}}$ or the $\overline{\text{PWRDWN}}$ pin is deasserted, depending upon parasitic capacitance on the XTALI and XTALO pins outside the AD1843. Because these parasitics are a function of the board design and layout, the exact amount of time required for the crystal to start to oscillate, and the internal clocks to stabilize cannot be known exactly in advance.

PDNO Converter Power-Down Flag. This bit is set to “1” if the AD1843 conversion resources are powered down, or are in the process of entering or exiting power down. Conversion resources are all resources in the AD1843 with the exception of the three clock generators and the serial interface. Conversion power-down is entered if either the power-down pin ($\overline{\text{PWRDWN}}$) is driven LO, or if the PDNI (Converter Power Down) bit in Control Register Address 28 is asserted. Power down is exited only if both pin ($\overline{\text{PWRDWN}}$) and bit (PDNI) are deasserted. When this bit is set to “1,” Control Registers may still be read, but only Control Registers 16–24, 26 and 28 which do not manage conversion resources may be written. See the “Power Management” section for further details. This bit is set to “1” immediately after a reset since the PDNI bit is initially asserted after a reset.

ID3:0 Revision Identification. These bits define the revision level of the AD1843. The first version of the AD1843 is “0001.”

res Reserved for future expansion. To ensure future compatibility, write “0” to all reserved bits.
Initial default state after reset: 1100 0000 0000 0001 (C001 hex). Cleared to default and cannot be written to when: the $\overline{\text{RESET}}$ pin is asserted LO; or when the $\overline{\text{PWRDWN}}$ pin is asserted LO.

Address 1								Channel Status Flags							
Data 15		Data 14		Data 13		Data 12		Data 11		Data 10		Data 9		Data 8	
res		res		res		res		res		res		SU2		SU1	
Data 7		Data 6		Data 5		Data 4		Data 3		Data 2		Data 1		Data 0	
res		res		res		res		OVR1		OVR0		OVL1		OVL0	

This register is cleared to all “0” after any read or write access.

SU2 DAC2 Sample Underrun. When set to “1,” this bit indicates that the four word stereo input buffer for DAC pair 2 ran out of samples. If this occurs, zeros are used in place of the unavailable data. This bit is “sticky” and is cleared after any write to this register. It is also cleared by powering down DAC2 (see the DA2EN bit in Control Register Address 27).

SU1 DAC1 Sample Underrun. When set to “1,” this bit indicates that the four word stereo input buffer for DAC pair 1 ran out of samples. If this occurs, zeros are used in place of the unavailable data. This bit is “sticky” and is cleared after any write to this register. It is also cleared by powering down DAC1 (see the DA1EN bit in Control Register Address 27).

OVR1:0 ADC Right Overrange Detect. These bits record the largest output magnitude on the ADC right channel and are cleared to “00” after any write to this register. The peak amplitude as recorded by these bits is “sticky,” i.e., the largest output magnitude recorded by these bits will persist until these bits are explicitly cleared. They are also cleared by powering down the ADC right channel (see the ADREN bit in Control Register Address 27).

00 = Greater than –1.0 dB underrange

01 = Between –1.0 dB and 0 dB underrange

10 = Between 0 dB and 1 dB overrange

11 = Greater than 1.0 dB overrange

- OVL1:0** ADC Left Overrange Detect. These bits record the largest output magnitude on the ADC left channel and are cleared to “00” after any write to this register. The peak amplitude as recorded by these bits is “sticky,” i.e., the largest output magnitude recorded by these bits will persist until these bits are explicitly cleared. They are also cleared by powering down the ADC left channel (see the ADLEN bit in Control Register Address 27).
- 00 = Greater than –1.0 dB underrange
 01 = Between –1.0 dB and 0 dB underrange
 10 = Between 0 dB and 1 dB overrange
 11 = Greater than 1.0 dB overrange
- res** Reserved for future expansion. To ensure future compatibility, write “0” to all reserved bits.
- Initial default state after reset: 0000 0000 0000 0000 (0000 hex). Cleared to default when: the $\overline{\text{RESET}}$ pin is asserted LO; when the $\overline{\text{PWRDWN}}$ pin is asserted LO; or when the PDNO bit in Control Register Address 0 is set to “1” (all conversions disabled).

Address 2		Input Control—ADC Source and Gain/Attenuation							
Data 15	Data 14	Data 13	Data 12	Data 11	Data 10	Data 9	Data 8	Data 7	Data 6
LSS2	LSS1	LSS0	LMGE	LIG3	LIG2	LIG1	LIG0	RSS2	RSS1
Data 5	Data 4	Data 3	Data 2	Data 1	Data 0				
RSS0	RMGE	RIG3	RIG2	RIG1	RIG0				

- LSS2:0** Left ADC Source Select
 000 = Left Line Input
 001 = Left Mic Input
 010 = Left Auxiliary 1 Input
 011 = Left Auxiliary 2 Input
 100 = Left Auxiliary 3 Input
 101 = Mono Input
 110 = Left DAC1 Output
 111 = Left DAC2 Output
- LMGE** Left ADC Microphone Gain Enable
 0 = 0 dB Gain
 1 = +20 dB Gain
- LIG3:0** Left ADC Input Gain. Least significant bit represents +1.5 dB.
 0000 = 0.0 dB Gain
 1111 = +22.5 dB Gain
- RSS2:0** Right ADC Source Select
 000 = Right Line Input
 001 = Right Mic Input
 010 = Right Auxiliary 1 Input
 011 = Right Auxiliary 2 Input
 100 = Right Auxiliary 3 Input
 101 = Mono Input
 110 = Right DAC1 Output
 111 = Right DAC2 Output
- RMGE** Right ADC Microphone Gain Enable
 0 = 0 dB Gain
 1 = +20 dB Gain
- RIG3:0** Right ADC Input Gain. Least significant bit represents +1.5 dB.
 0000 = 0.0 dB Gain
 1111 = +22.5 dB Gain

Initial Default State after Reset: 0000 0000 0000 0000 (0000 hex). Cleared to default and cannot be written to when: the $\overline{\text{RESET}}$ pin is asserted LO; when the $\overline{\text{PWRDWN}}$ pin is asserted LO; or when the PDNO bit in Control Register 0 is set to “1” (all conversions disabled).

AD1843

Address 3		Mix Control—DAC2 to Mixer					
Data 15	Data 14	Data 13	Data 12	Data 11	Data 10	Data 9	Data 8
LD2MM	res	res	LD2M4	LD2M3	LD2M2	LD2M1	LD2M0
Data 7	Data 6	Data 5	Data 4	Data 3	Data 2	Data 1	Data 0
RD2MM	res	res	RD2M4	RD2M3	RD2M2	RD2M1	RD2M0

- LD2MM** Left DAC2 Mix Mute
0 = Mix Enabled
1 = Mix Muted
- LD2M4:0** Left DAC2 Mix Gain/Attenuation Select. Least significant bit represents –1.5 dB. Referred to 2.0 V p-p DAC2 output level.
00000 = +12.0 dB Gain
01000 = 0.0 dB
11111 = –34.5 dB Attenuation
- RD2MM** Right DAC2 Mix Mute
0 = Mix Enabled
1 = Mix Muted
- RD2M4:0** Right DAC2 Mix Gain/Attenuation Select. Least significant bit represents –1.5 dB. Referred to 2.0 V p-p DAC2 output level.
00000 = +12.0 dB Gain
01000 = 0.0 dB
11111 = –34.5 dB Attenuation
- res** Reserved for future expansion. To ensure future compatibility, write “0” to all reserved bits.
Initial default state after reset: 1000 1000 1000 1000 (8888 hex). Cleared to default and cannot be written to when: the $\overline{\text{RESET}}$ pin is asserted LO; when the $\overline{\text{PWRDWN}}$ pin is asserted LO; when the PDNO bit in Control Register Address 0 is set to “1” (all conversions disabled); or when the DDMEN bit (DAC2 to DAC1 analog mix disabled), the DA2EN bit (DAC2 powered down), or the ANAEN bit (analog channels powered down) in Control Register Address 27 is reset to “0.”

Address 4		Mix Control—Auxiliary 1 to DAC1					
Data 15	Data 14	Data 13	Data 12	Data 11	Data 10	Data 9	Data 8
LX1MM	res	res	LX1M4	LX1M3	LX1M2	LX1M1	LX1M0
Data 7	Data 6	Data 5	Data 4	Data 3	Data 2	Data 1	Data 0
RX1MM	res	res	RX1M4	RX1M3	RX1M2	RX1M1	RX1M0

- LX1MM** Left Auxiliary 1 Mix Mute
0 = Mix Enabled
1 = Mix Muted
- LX1M4:0** Left Auxiliary 1 Mix Gain/Attenuation Select. Least significant bit represents –1.5 dB. Referred to 2.0 V p-p DAC1 output level.
00000 = +12.0 dB Gain
01000 = 0.0 dB
11111 = –34.5 dB Attenuation
- RX1MM** Right Auxiliary 1 Mix Mute
0 = Mix Enabled
1 = Mix Muted
- RX1M4:0** Right Auxiliary 1 Mix Gain/Attenuation Select. Least significant bit represents –1.5 dB. Referred to 2.0 V p-p DAC1 output level.
00000 = +12.0 dB Gain
01000 = 0.0 dB
11111 = –34.5 dB Attenuation

res Reserved for future expansion. To ensure future compatibility, write “0” to all reserved bits.
Initial default state after reset: 1000 1000 1000 1000 (8888 hex). Cleared to default and cannot be written to when: the $\overline{\text{RESET}}$ pin is asserted LO; when the $\overline{\text{PWRDWN}}$ pin is asserted LO; when the PDNO bit in Control Register Address 0 is set to “1” (all conversions disabled); or when the AAMEN bit (analog input to analog mix disabled), or the ANAEN bit (analog channels powered down) in Control Register Address 27 is reset to “0.”

Address 5		Mix Control—Auxiliary 2 to Mixer							
Data 15	Data 14	Data 13	Data 12	Data 11	Data 10	Data 9	Data 8	Data 7	Data 6
LX2MM	res	res	LX2M4	LX2M3	LX2M2	LX2M1	LX2M0		
Data 7	Data 6	Data 5	Data 4	Data 3	Data 2	Data 1	Data 0		
RX2MM	res	res	RX2M4	RX2M3	RX2M2	RX2M1	RX2M0		

LX2MM Left Auxiliary 2 Mix Mute
0 = Mix Enabled
1 = Mix Muted

LX2M4:0 Left Auxiliary 2 Mix Gain/Attenuation Select. Least significant bit represents –1.5 dB. Referred to 2.0 V p-p DAC1 output level.
00000 = +12.0 dB Gain
01000 = 0.0 dB
11111 = –34.5 dB Attenuation

RX2MM Right Auxiliary 2 Mix Mute
0 = Mix Enabled
1 = Mix Muted

RX2M4:0 Right Auxiliary 2 Mix Gain/Attenuation Select. Least significant bit represents –1.5 dB. Referred to 2.0 V p-p DAC1 output level.
00000 = +12.0 dB Gain
01000 = 0.0 dB
11111 = –34.5 dB Attenuation

res Reserved for future expansion. To ensure future compatibility, write “0” to all reserved bits.
Initial default state after reset: 1000 1000 1000 1000 (8888 hex). Cleared to default and cannot be written to when: the $\overline{\text{RESET}}$ pin is asserted LO; when the $\overline{\text{PWRDWN}}$ pin is asserted LO; when the PDNO bit in Control Register Address 0 is set to “1” (all conversions disabled); or when the AAMEN bit (analog input to analog mix disabled), or the ANAEN bit (analog channels powered down) in Control Register Address 27 is reset to “0.”

Address 6		Mix Control—Auxiliary 3 to Mixer							
Data 15	Data 14	Data 13	Data 12	Data 11	Data 10	Data 9	Data 8	Data 7	Data 6
LX3MM	res	res	LX3M4	LX3M3	LX3M2	LX3M1	LX3M0		
Data 7	Data 6	Data 5	Data 4	Data 3	Data 2	Data 1	Data 0		
RX3MM	res	res	RX3M4	RX3M3	RX3M2	RX3M1	RX3M0		

LX3MM Left Auxiliary 3 Mix Mute
0 = Mix Enabled
1 = Mix Muted

LX3M4:0 Left Auxiliary 3 Mix Gain/Attenuation Select. Least significant bit represents –1.5 dB. Referred to 2.0 V p-p DAC1 output level.
00000 = +12.0 dB Gain
01000 = 0.0 dB
11111 = –34.5 dB Attenuation

AD1843

RX3MM Right Auxiliary 3 Mix Mute
 0 = Mix Enabled
 1 = Mix Muted

RX3M4:0 Right Auxiliary 3 Mix Gain/Attenuation Select. Least significant bit represents –1.5 dB. Referred to 2.0 V p-p DAC1 output level.
 00000 = +12.0 dB Gain
01000 = 0.0 dB
 11111 = –34.5 dB Attenuation

res Reserved for future expansion. To ensure future compatibility, write “0” to all reserved bits.
 Initial default state after reset: 1000 1000 1000 1000 (8888 hex). Cleared to default and cannot be written to when: the $\overline{\text{RESET}}$ pin is asserted LO; when the $\overline{\text{PWRDWN}}$ pin is asserted LO; when the PDNO bit in Control Register Address 0 is set to “1” (all conversions disabled); or when the AAMEN bit (analog input to analog mix disabled), or the ANAEN bit (analog channels powered down) in Control Register Address 27 is reset to “0.”

Address 7								Mix Control—Mic to Mixer							
Data 15		Data 14		Data 13		Data 12		Data 11		Data 10		Data 9		Data 8	
LMCMM	res	res	res	LMCM4	LMCM3	LMCM2	LMCM1	LMCM0							
Data 7		Data 6		Data 5		Data 4		Data 3		Data 2		Data 1		Data 0	
RMCM4	res	res	res	RMCM4	RMCM3	RMCM2	RMCM1	RMCM0							

LMCMM Left Microphone Mix Mute
 0 = Mix Enabled
 1 = Mix Muted

LMCM4:0 Left Microphone Mix Gain/Attenuation Select. Least significant bit represents –1.5 dB. Referred to 2.0 V p-p DAC1 output level.
 00000 = +12.0 dB Gain
01000 = 0.0 dB
 11111 = –34.5 dB Attenuation

RMCM4 Right Microphone Mix Mute
 0 = Mix Enabled
 1 = Mix Muted

RMCM4:0 Right Microphone Mix Gain/Attenuation Select. Least significant bit represents –1.5 dB. Referred to 2.0 V p-p DAC1 output level.
 00000 = +12.0 dB Gain
01000 = 0.0 dB
 11111 = –34.5 dB Attenuation

res Reserved for future expansion. To ensure future compatibility, write “0” to all reserved bits.
 Initial default state after reset: 1000 1000 1000 1000 (8888 hex). Cleared to default and cannot be written to when: the $\overline{\text{RESET}}$ pin is asserted LO; when the $\overline{\text{PWRDWN}}$ pin is asserted LO; when the PDNO bit in Control Register Address 0 is set to “1” (all conversions disabled); or when the AAMEN bit (analog input to analog mix disabled), or the ANAEN bit (analog channels powered down) in Control Register Address 27 is reset to “0.”

Address 8								Mix/Miscellaneous Control—Mono In to Mixer and Miscellaneous Settings							
Data 15		Data 14		Data 13		Data 12		Data 11		Data 10		Data 9		Data 8	
MNMM	res	res	res	MNM4	MNM3	MNM2	MNM1	MNM0							
Data 7		Data 6		Data 5		Data 4		Data 3		Data 2		Data 1		Data 0	
ALLMM	MNOM	HPOM	HPOS	SUMM	res	DAC2T	DAC1T								

MNMM Mono Input Mix Mute
 0 = Mix Enabled
 1 = Mix Muted

MNM4:0	Left and Right Mono Mix Gain/Attenuation Select. Least significant bit represents -1.5 dB. 00000 = $+12.0$ dB Gain 01000 = 0.0 dB 11111 = -34.5 dB Attenuation
ALLMM	All Mix Mute. Mutes all mixing (MIC, AUX1, AUX2, AUX3, and DAC2) to left and right DAC1, overriding the independent mute control bits in Control Register Addresses 3 through 8. 0 = Mix to DAC1 Enabled 1 = Mix to DAC1 Muted
MNOM	Mono Output Mute 0 = Mono Output Enabled 1 = Mono Output Muted
HPOM	Headphone Output Mute (Left and Right) 0 = Headphone Output Enabled 1 = Headphone Output Muted
HPOS	Headphone Output Voltage Swing (Left and Right) 0 = 2 volts peak-to-peak 1 = 4 volts peak-to-peak
SUMM	Sum Left and Right Mute. Mutes mixing from SUML and SUMR pins to DAC1. 0 = SUML and SUMR Mix to DAC1 Enabled 1 = SUML and SUMR Mix to DAC1 Muted
DAC2T	DAC2 Gain/Attenuation Change Timing. This bit controls when changes to the DAC2 gain/attenuation setting (Control Register 10) take effect. When set to "1," changes take effect immediately. When reset to "0," changes are delayed until either the output level on DAC2 crosses zero (midscale), or until after a 10 to 12 ms time-out period is reached. Delaying gain/attenuation changes until zero crossings reduces instantaneous output voltage changes, which reduces audible "clicks." 0 = Gain/Attenuation Changes Applied on Signal Zero Crossing or After a 10-12 ms Time-Out 1 = Gain/Attenuation Changes Applied Immediately
DAC1T	DAC1 Gain/Attenuation Change Timing. This bit controls when changes to the DAC1 gain/attenuation setting (Control Register 9) take effect. When set to "1," changes take effect immediately. When reset to "0," changes are delayed until either the output level on DAC1 crosses zero (midscale), or until after a 10 to 12 ms time-out period is reached. Delaying gain/attenuation changes until zero crossings reduces instantaneous output voltage changes, which reduces audible "clicks." 0 = Gain/Attenuation Changes Applied on Signal Zero Crossing or After a 10-12 ms Time-Out 1 = Gain/Attenuation Changes Applied Immediately
res	Reserved for future expansion. To ensure future compatibility, write "0" to all reserved bits. Initial default state after reset: 1000 1000 0110 1000 (8868 hex). Cleared to default and cannot be written to when: the RESET pin is asserted LO; when the PWRDWN pin is asserted LO; or when the PDNO bit in Control Register Address 0 is set to "1" (all conversions powered down). The MSB half (Data 15 through Data 8) of this Control Register is cleared to default and cannot be written to also when: the AAMEN bit (analog input to analog mix disabled), or the ANAEN bit (analog channels powered down) in Control Register 27 is reset to "0."

Address 9		Output Control—DAC1 Analog Gain/Attenuation					
Data 15	Data 14	Data 13	Data 12	Data 11	Data 10	Data 9	Data 8
LDA1GM	res	LDA1G5	LDA1G4	LDA1G3	LDA1G2	LDA1G1	LDA1G0
Data 7	Data 6	Data 5	Data 4	Data 3	Data 2	Data 1	Data 0
RDA1GM	res	RDA1G5	RDA1G4	RDA1G3	RDA1G2	RDA1G1	RDA1G0

LDA1GM	Left DAC1 Analog Mute 0 = Left DAC1 Enabled 1 = Left DAC1 Muted
--------	---

AD1843

LDA1G5:0 Left DAC1 Analog/Digital Gain/Attenuation Select. Least significant bit represents –1.5 dB. Note that the implementation of the attenuation is mixed analog and digital.

0 00000 =	+12.0 dB:	+12.0 dB Analog,	+0.0 dB Digital
0 01000 =	0.0 dB:	+0.0 dB Analog,	+0.0 dB Digital
0 11111 =	–34.5 dB:	–34.5 dB Analog,	+0.0 dB Digital
1 00000 =	–36.0 dB:	–34.5 dB Analog,	–1.5 dB Digital
1 11111 =	–82.5 dB:	–34.5 dB Analog,	–48.0 dB Digital

RDA1GM Right DAC1 Analog Mute
 0 = Right DAC1 Enabled
 1 = Right DAC1 Muted

RDA1G5:0 Right DAC1 Analog/Digital Gain/Attenuation Select. Least significant bit represents –1.5 dB. Note that the implementation of the attenuation is mixed analog and digital.

0 00000 =	+12.0 dB:	+12.0 dB Analog,	+0.0 dB Digital
0 01000 =	0.0 dB:	+0.0 dB Analog,	+0.0 dB Digital
0 11111 =	–34.5 dB:	–34.5 dB Analog,	+0.0 dB Digital
1 00000 =	–36.0 dB:	–34.5 dB Analog,	–1.5 dB Digital
1 11111 =	–82.5 dB:	–34.5 dB Analog,	–48.0 dB Digital

res Reserved for future expansion. To ensure future compatibility, write “0” to all reserved bits.

Initial default state after reset: 1000 1000 1000 1000 (8888 hex). Cleared to default and cannot be written to when: the $\overline{\text{RESET}}$ pin is asserted LO; when the $\overline{\text{PWRDWN}}$ pin is asserted LO; when the PDNO bit in Control Register Address 0 is set to “1” (all conversions disabled); when the ANAEN bit in Control Register Address 27 is reset to “0” (analog channels powered down); or when the DA1EN bit in Control Register Address 27 is reset to “0” (DAC1 disabled).

Address 10		Output Control—DAC2 Analog Gain/Attenuation					
Data 15	Data 14	Data 13	Data 12	Data 11	Data 10	Data 9	Data 8
LDA2GM	res	LDA2G5	LDA2G4	LDA2G3	LDA2G2	LDA2G1	LDA2G0
Data 7	Data 6	Data 5	Data 4	Data 3	Data 2	Data 1	Data 0
RDA2GM	res	RDA2G5	RDA2G4	RDA2G3	RDA2G2	RDA2G1	RDA2G0

LDA2GM Left DAC2 Analog Mute
 0 = Left DAC2 Enabled
 1 = Left DAC2 Muted

LDA2G5:0 Left DAC2 Analog/Digital Gain/Attenuation Select. Least significant bit represents –1.5 dB. Note that the implementation of the attenuation is mixed analog and digital.

0 00000 =	+12.0 dB:	+12.0 dB Analog,	+0.0 dB Digital
0 01000 =	0.0 dB:	+0.0 dB Analog,	+0.0 dB Digital
0 11111 =	–34.5 dB:	–34.5 dB Analog,	+0.0 dB Digital
1 00000 =	–36.0 dB:	–34.5 dB Analog,	–1.5 dB Digital
1 11111 =	–82.5 dB:	–34.5 dB Analog,	–48.0 dB Digital

RDA2GM Right DAC2 Analog Mute
 0 = Right DAC2 Enabled
 1 = Right DAC2 Muted

RDA2G5:0 Right DAC2 Analog/Digital Gain/Attenuation Select. Least significant bit represents –1.5 dB. Note that the implementation of the attenuation is mixed analog and digital.

0 00000 =	+12.0 dB:	+12.0 dB Analog,	+0.0 dB Digital
0 01000 =	0.0 dB:	+0.0 dB Analog,	+0.0 dB Digital
0 11111 =	–34.5 dB:	–34.5 dB Analog,	+0.0 dB Digital
1 00000 =	–36.0 dB:	–34.5 dB Analog,	–1.5 dB Digital
1 11111 =	–82.5 dB:	–34.5 dB Analog,	–48.0 dB Digital

res Reserved for future expansion. To ensure future compatibility, write “0” to all reserved bits.

Initial default state after reset: 1000 1000 1000 1000 (8888 hex). Cleared to default and cannot be written to when: the $\overline{\text{RESET}}$ pin is asserted LO; when the $\overline{\text{PWRDWN}}$ pin is asserted LO; when the PDNO bit in Control Register Address 0 is set to “1” (all conversions disabled); when the ANAEN bit in Control Register Address 27 is reset to “0” (analog channels powered down); or when the DA2EN bit in Control Register Address 27 is reset to “0” (DAC2 disabled).

Address 11		Output Control—DAC1 Digital Attenuation					
Data 15	Data 14	Data 13	Data 12	Data 11	Data 10	Data 9	Data 8
LDA1AM	res	LDA1A5	LDA1A4	LDA1A3	LDA1A2	LDA1A1	LDA1A0
Data 7	Data 6	Data 5	Data 4	Data 3	Data 2	Data 1	Data 0
RDA1AM	res	RDA1A5	RDA1A4	RDA1A3	RDA1A2	RDA1A1	RDA1A0

LDA1AM Left DAC1 Digital Mute
0 = Left DAC1 Enabled
1 = Left DAC1 Muted

LDA1A5:0 Left DAC1 Digital Attenuation Select. Least significant bit represents –1.5 dB.
000000 = +0.0 dB Attenuation
111111 = –94.5 dB Attenuation

RDA1AM Right DAC1 Digital Mute
0 = Right DAC1 Enabled
1 = Right DAC1 Muted

RDA1A5:0 Right DAC1 Digital Attenuation Select. Least significant bit represents –1.5 dB.
000000 = +0.0 dB Attenuation
111111 = –94.5 dB Attenuation

res Reserved for future expansion. To ensure future compatibility, write “0” to all reserved bits.

Initial default state after reset: 0000 0000 0000 0000 (0000 hex). Cleared to default and cannot be written to when: the $\overline{\text{RESET}}$ pin is asserted LO; when the $\overline{\text{PWRDWN}}$ pin is asserted LO; or when the PDNO bit in Control Register Address 0 is set to “1” (all conversions disabled).

Address 12		Output Control—DAC2 Digital Attenuation					
Data 15	Data 14	Data 13	Data 12	Data 11	Data 10	Data 9	Data 8
LDA2AM	res	LDA2A5	LDA2A4	LDA2A3	LDA2A2	LDA2A1	LDA2A0
Data 7	Data 6	Data 5	Data 4	Data 3	Data 2	Data 1	Data 0
RDA2AM	res	RDA2A5	RDA2A4	RDA2A3	RDA2A2	RDA2A1	RDA2A0

LDA2AM Left DAC2 Digital Mute
0 = Left DAC2 Enabled
1 = Left DAC2 Muted

LDA2A5:0 Left DAC2 Digital Attenuation Select. Least significant bit represents –1.5 dB.
000000 = +0.0 dB Attenuation
111111 = –94.5 dB Attenuation

RDA2AM Right DAC2 Digital Mute
0 = Right DAC2 Enabled
1 = Right DAC2 Muted

RDA2A5:0 Right DAC2 Digital Attenuation Select. Least significant bit represents –1.5 dB.
000000 = +0.0 dB Attenuation
111111 = –94.5 dB Attenuation

res Reserved for future expansion. To ensure future compatibility, write “0” to all reserved bits.

Initial default state after reset: 0000 0000 0000 0000 (0000 hex). Cleared to default and cannot be written to when: the $\overline{\text{RESET}}$ pin is asserted LO; when the $\overline{\text{PWRDWN}}$ pin is asserted LO; or when the PDNO bit in Control Register Address 0 is set to “1” (all conversions disabled).

AD1843

Address 13		Digital Mix Control—ADC to DAC1					
Data 15	Data 14	Data 13	Data 12	Data 11	Data 10	Data 9	Data 8
LAD1MM	res	LAD1M5	LAD1M4	LAD1M3	LAD1M2	LAD1M1	LAD1M0
Data 7	Data 6	Data 5	Data 4	Data 3	Data 2	Data 1	Data 0
RAD1MM	res	RAD1M5	RAD1M4	RAD1M3	RAD1M2	RAD1M1	RAD1M0

Restrictions: ADC and DAC channel mixed must receive conversion rate from same Clock Generator. Serial interface must be running at a rate greater than or equal to the ADC/DAC conversion rate. For bus master: SDFS frequency \geq ADC/DAC conversion rate. For bus slave: TSI frequency \geq ADC/DAC conversion rate.

LAD1MM Digital Mix of Left ADC Output with Left DAC1 Input Mute.
 0 = Mix Enabled
 1 = Mix Muted

LAD1M5:0 Digital Mix of Left ADC Output with Left DAC1 Input Attenuation Select. Least significant bit represents -1.5 dB.
000000 = $+0.0$ dB Attenuation
111110 = -93.0 dB Attenuation
111111 = Full Mute

RAD1MM Digital Mix of Right ADC Output with Right DAC1 Input Mute.
 0 = Mix Enabled
 1 = Mix Muted

RAD1M5:0 Digital Mix of Right ADC Output with Right DAC1 Input Attenuation Select. Least significant bit represents -1.5 dB.
000000 = $+0.0$ dB Attenuation
111110 = -93.0 dB Attenuation
111111 = Full Mute

res Reserved for future expansion. To ensure future compatibility, write “0” to all reserved bits.

Initial default state after reset: 1000 0000 1000 0000 (8080 hex). Cleared to default and cannot be written to when: the **RESET** pin is asserted LO; when the **PWRDWN** pin is asserted LO; or when the **PDNO** bit in Control Register Address 0 is set to “1” (all conversions disabled).

Address 14		Digital Mix Control—ADC to DAC2					
Data 15	Data 14	Data 13	Data 12	Data 11	Data 10	Data 9	Data 8
LAD2MM	res	LAD2M5	LAD2M4	LAD2M3	LAD2M2	LAD2M1	LAD2M0
Data 7	Data 6	Data 5	Data 4	Data 3	Data 2	Data 1	Data 0
RAD2MM	res	RAD2M5	RAD2M4	RAD2M3	RAD2M2	RAD2M1	RAD2M0

Restrictions: ADC and DAC channel mixed must receive conversion rate from same Clock Generator. Serial interface must be running at a rate greater than or equal to the ADC/DAC conversion rate. For bus master: SDFS frequency \geq ADC/DAC conversion rate. For bus slave: TSI frequency \geq ADC/DAC conversion rate.

LAD2MM Digital Mix of Left ADC Output with Left DAC2 Input Mute.
 0 = Mix Enabled
 1 = Mix Muted

LAD2M5:0 Digital Mix of Left ADC Output with Left DAC2 Input Attenuation Select. Least significant bit represents -1.5 dB.
000000 = $+0.0$ dB Attenuation
111110 = -93.0 dB Attenuation
111111 = Full Mute

RAD2MM Digital Mix of Right ADC Output with Right DAC2 Input Mute.
 0 = Mix Enabled
 1 = Mix Muted

RAD2M5:0 Digital Mix of Right ADC Output with Right DAC2 Input Attenuation Select. Least significant bit represents -1.5 dB.
000000 = $+0.0$ dB Attenuation
111110 = -93.0 dB Attenuation
111111 = Full Mute

res Reserved for future expansion. To ensure future compatibility, write “0” to all reserved bits.

Initial default state after reset: 1000 0000 1000 0000 (8080 hex). Cleared to default and cannot be written to when: the **RESET** pin is asserted LO; when the **PWRDWN** pin is asserted LO; or when the **PDNO** bit in Control Register Address 0 is set to “1” (all conversions disabled).

Address 15		Codec Configuration—Channel Sample Rate Source Select					
Data 15	Data 14	Data 13	Data 12	Data 11	Data 10	Data 9	Data 8
res	res	res	res	DA2C1	DA2C0	DA1C1	DA1C0
Data 7	Data 6	Data 5	Data 4	Data 3	Data 2	Data 1	Data 0
res	res	res	res	ADRC1	ADRC0	ADLC1	ADLC0

- DA2C1:0 DAC2 Sample Rate Source. Selects the sample rate clock source for left and right channels of DAC2.
00 = Conversion Sample Rate is 48.0 kHz
01 = Conversion Sample Rate is from Clock Generator 1
10 = Conversion Sample Rate is from Clock Generator 2
11 = Conversion Sample Rate is from Clock Generator 3
- DA1C1:0 DAC1 Sample Rate Source. Selects the sample rate clock source for left and right channels of DAC1.
00 = Conversion Sample Rate is 48.0 kHz
01 = Conversion Sample Rate is from Clock Generator 1
10 = Conversion Sample Rate is from Clock Generator 2
11 = Conversion Sample Rate is from Clock Generator 3
- ADRC1:0 ADC Right Sample Rate Source. Selects the sample rate clock source for the right ADC channel.
00 = Conversion Sample Rate is 48.0 kHz
01 = Conversion Sample Rate is from Clock Generator 1
01 = Conversion Sample Rate is from Clock Generator 2
11 = Conversion Sample Rate is from Clock Generator 3
- ADLC1:0 ADC Left Sample Rate Source. Selects the sample rate clock source for the left ADC channel.
00 = Conversion Sample Rate is 48.0 kHz
01 = Conversion Sample Rate is from Clock Generator 1
10 = Conversion Sample Rate is from Clock Generator 2
11 = Conversion Sample Rate is from Clock Generator 3
- res Reserved for future expansion. To ensure future compatibility, write “0” to all reserved bits.
 Initial default state after reset: 0000 0000 0000 0000 (0000 hex). Cleared to default and cannot be written to when: the $\overline{\text{RESET}}$ pin is asserted LO; when the $\overline{\text{PWRDWN}}$ pin is asserted LO; or when the PDNO bit in Control Register Address 0 is set to “1” (all conversions disabled).

Address 16		Clock Generator 1 Control—Mode					
Data 15	Data 14	Data 13	Data 12	Data 11	Data 10	Data 9	Data 8
C1REF	C1VID	C1PLLG	C1P200	C1X8/7	C1C128	res	res
Data 7	Data 6	Data 5	Data 4	Data 3	Data 2	Data 1	Data 0
C1M7	C1M6	C1M5	C1M4	C1M3	C1M2	C1M1	C1M0

- C1REF Clock Generator 1 Reference Select. Selects the fundamental clock reference used by Clock Generator 1 to synthesize its “Conversion” (sample) and “Bit” clock rates.
- 0** = Clocks are referenced to the input on pin XTALI (crystal or master clock input).
 Sample clock frequency is defined by Control Register Address 17 and Bit C1X8/7.
 Sample clock phase may be shifted by Control Register Address 18.
 Bit clock frequency is defined by bits C1M7:0 and C1P200.
 Bit C1VID is ignored.
- 1** = Clocks are referenced to the input on pin SYNC1 (Sync 1 Clock Input).
 Sample clock frequency is defined by C1VID and C1M7:0.
 Sample clock phase is locked to SYNC1 and cannot be shifted.
 Bit clock frequency is defined by bits C1M7:0 and C1P200 unless in Video Lock Mode (C1VID set to “1”) where the Bit clocks are not produced.
 Control Register Addresses 17, 18 and the C1X8/7 bit are ignored.

AD1843

- C1VID** Clock Generator 1 Video Lock Mode. This bit is used to select between lock modes when the Clock Generator 1 is referenced to SYNC1 (C1REF set to “1”). This bit should be reset to “0” if C1REF is reset to “0.” When reset to “0,” Clock Generator 1 is in *normal* lock mode where the Conversion clock will be frequency and phase locked to SYNC1, and the Bit clock frequency is chosen using bits C1M7:0 and C1P200. When set to “1,” Clock Generator 1 is in *video* lock mode, where the Conversion clock frequency is selected using bits C1M7:0, and a Bit clock is not produced.
- C1PLLG** Clock Generator 1 PLL Loop Gain Select. If reset to “0,” this bit selects finite PLL loop gain, and if set to “1,” this bit selects infinite PLL loop gain. This bit should nominally be reset to “0.” Setting it to “1” may enhance the PLL’s ability to lock to certain SYNC1 inputs, but it may also increase conversion noise.
- C1P200** Clock Generator 1 Bit Clock +200 Frequency Modifier. When set to “1,” the Bit clock driven out of pin BIT1 will have a frequency that is 200 Hertz greater than the frequency selected through bit C1M7:0. This bit is ignored when in Video Lock Mode (C1VID set to “1”). C1P200 only modifies the bit clock driven on the BIT1 pin.
- C1X8/7** Clock Generator 1 Conversion Clock 8/7 Frequency Modifier. When set to “1,” the Conversion clock frequency generated will be 8/7 times the value programmed in Control Register Address 17. This bit is ignored when clocks are referenced to SYNC1 (C1REF set to “1”).
- C1C128** Clock Generator 1 Conversion Clock Pin (CONV1) Frequency Select. When set to “1,” the frequency driven on to the CONV1 pin will be 128 times the conversion rate. When reset to “0,” the frequency driven on to the CONV1 pin will be the same as the conversion rate. C1C128 only modifies the clock frequency driven on the CONV1 pin.
- res** Reserved for future expansion. To ensure future compatibility, write “0” to all reserved bits.
- C1M7:0** Clock Generator 1 Clock Rate Modifiers.

When not in Video Lock Mode (C1REF and C1VID are not both set to “1”):

Bits C1M7:0 select the Bit clock rate which will be driven out on pin BIT1. Using the following table, the least significant four bits (C1M3:0) are programmed to the desired Bit clock rate, and the most significant four bits (C1M7:4) must be programmed to the Conversion clock rate established using Control Register Address 17 and the C1X8/7 bit. If the actual Conversion clock differs from the value selected by C1M7:4, then the resultant Bit clock will be different from the rate selected by the ratio of the C1M7:4 selected rate to the Control Register Address 17 plus the C1X8/7 bit actual rate.

C1M3:0	Bit Clock Frequency*	C1M7:4	Conversion (Sample) Rate
0000	2,400 Hertz	0000	7,200 Hertz
0001	4,800	0001	8,400
0010	7,200	0010	9,000
0011	9,600	0011	9,600
0100	12,000	0100	11,200
0101	14,400	0101	12,000
0110	16,800	0110	12,800
0111	19,200	0111	7,200 × 8/7
1000	21,600	1000	9,000 × 8/7
1001	24,000	1001	9,600 × 8/7
1010	26,400	1010	12,000 × 8/7
1011	28,800	1011	Reserved
1100	Reserved	1100	Reserved
1101	Reserved	1101	Reserved
1110	Reserved	1110	Reserved
1111	See Below	1111	See Below

*Bit clock frequencies listed will be increased by 200 Hz if C1P200 is set to “1.”

When C1M7:4 is programmed to “1111” and C1M3:0 is programmed to “1111,” the Bit clock rate will be 128 times the Conversion rate.

When in Video Lock Mode (C1REF and C1VID are both set to “1”):

Bits C1M7:0 select the Conversion clock rate. The most significant bit (C1M7) must be set to indicate the type of video lock, either NTSC or PAL. For an NTSC lock, C1M7 must be reset to “0,” and the SYNC1 pin must receive the NTSC sync frequency (525 lines/frame × 30 Hz × 1000/1001 frame rate ≈ 15.734 kHz). For a PAL lock, C1M7 must be set to “1,” and the SYNC1 pin must receive the PAL sync frequency (625 lines/frame × 25 Hz frame rate ≈ 15.625 kHz). The next three most significant bits (C1M6:4) select a desired *base* Conversion clock rate, and the least significant four bits (C1M3:0) select a *divisor*. The Conversion clock created by Clock Generator 1 will be the *base* divided by the *divisor*. The following tables list the possible choices for base and divisor.

NTSC	(C1M7 = "0"):	Base Frequency In Hz (C1M6:4)					
		48,000	32,000	44,100	44,100 × 2/3	48,000*	44,056
<u>Divisor</u>	<u>(C1M3:0)</u>	(000)	(001)	(010)	(011)	(100)	(101)
1	(0000)	Yes	Yes	Yes	Yes	Yes	Yes
2	(0001)	Yes	Yes	Yes	Yes	Yes	Yes
3	(0010)	Yes	No	Yes	No	Yes	Yes
4	(0011)	Yes	Yes	Yes	Yes	Yes	Yes
5	(0100)	Yes	Yes	Yes	Yes	Yes	Yes
6	(0101)	Yes	No	Yes	No	Yes	Yes
7	(0110)	No	No	Yes	No	Yes	Yes
8	(0111)	Yes	No	Yes	No	Yes	Yes

*When C1M6:4 = "100," base frequency is 48,000 Hz only if NTSC sync rate is increased by 1001/1000, or is exactly 15.750 kHz.

PAL	(C1M7 = "1"):	Base Frequency In Hz (C1M6:4)			
		48,000	32,000	44,100	44,100 × 2/3
<u>Divisor</u>	<u>(C1M3:0)</u>	(000)	(001)	(010)	(011)
1	(0000)	Yes	Yes	Yes	Yes
2	(0001)	Yes	Yes	Yes	Yes
3	(0010)	Yes	No	Yes	No
4	(0011)	Yes	Yes	Yes	Yes
5	(0100)	Yes	Yes	Yes	Yes
6	(0101)	Yes	No	Yes	No
7	(0110)	Yes	No	Yes	No
8	(0111)	Yes	No	Yes	No

Initial default state after reset: 0000 0000 1111 1111 (00FF hex). Cleared to default and cannot be written to when: the **RESET** pin is asserted LO; or when the **PWRDWN** pin is asserted LO.

Address 17		Clock Generator 1 Control—Sample Rate					
Data 15	Data 14	Data 13	Data 12	Data 11	Data 10	Data 9	Data 8
C1C15	C1C14	C1C13	C1C12	C1C11	C1C10	C1C9	C1C8
Data 7	Data 6	Data 5	Data 4	Data 3	Data 2	Data 1	Data 0
C1C7	C1C6	C1C5	C1C4	C1C3	C1C2	C1C1	C1C0

C1C15:0 Clock Generator 1 Conversion (Sample) Rate Select. Defines the conversion rate produced by Clock Generator 1 when not referenced to the SYNC1 pin (Control Register Address 16 Bit 15 [C1REF]). One LSB represents exactly one Hertz, assuming a 24.576 MHz clock input on the XTALI pin. Usable range is 4 kHz (0x0FA0) to 54 kHz (0xD2F0).

Initial default state after reset: 1011 1011 1000 0000 (BB80 hex), which is 48 kHz, assuming a 24.576 MHz clock input on the XTALI pin. Cleared to default and cannot be written to when: the **RESET** pin is asserted LO; or when the **PWRDWN** pin is asserted LO.

Address 18		Clock Generator 1 Control—Sample Phase Shift					
Data 15	Data 14	Data 13	Data 12	Data 11	Data 10	Data 9	Data 8
res	res	res	res	res	res	res	C1PD
Data 7	Data 6	Data 5	Data 4	Data 3	Data 2	Data 1	Data 0
C1P7	C1P6	C1P5	C1P4	C1P3	C1P2	C1P1	C1P0

C1PD Clock Generator 1 Phase Shift Direction. This bit controls the direction of sample clock phase shift.
0 = Phase Advance
1 = Phase Retard

C1P7:0 Clock Generator 1 Phase Shift Magnitude. These bits control the magnitude of sample clock phase shift. One LSB represents exactly 0.12 degrees. LSBs are processed and decremented at a rate of 3.072 MHz (assuming a 24.576 MHz clock input on the XTALI pin). When this register is read, it indicates any phase advance/retard remaining to be processed as of the beginning of slot 0 if bus master, or when TSI was received if bus slave. This register may be

AD1843

overwritten even if all previously programmed phase advance/retard has not been processed. When written, the contents of this register (just prior to the write) are transmitted during slot 1 of the following frame (as with all Control Register writes).

res Reserved for future expansion. To ensure future compatibility, write “0” to all reserved bits.

Initial default state after reset: 0000 0000 0000 0000 (0000 hex). Cleared to default and cannot be written to when: the $\overline{\text{RESET}}$ pin is asserted LO; when the $\overline{\text{PWRDWN}}$ pin is asserted LO; or when the G1EN bit in Control Register Address 28 is reset to “0” (clock generator 1 disabled).

Address 19								Clock Generator 2 Control—Mode							
Data 15		Data 14		Data 13		Data 12		Data 11		Data 10		Data 9		Data 8	
C2REF		C2VID		C2PLLG		C2P200		C2X8/7		C2C128		res		res	
Data 7		Data 6		Data 5		Data 4		Data 3		Data 2		Data 1		Data 0	
C2M7		C2M6		C2M5		C2M4		C2M3		C2M2		C2M1		C2M0	

C2REF Clock Generator 2 Reference Select. Selects the fundamental clock reference used by Clock Generator 2 to synthesize its “Conversion” (sample) and “Bit” clock rates.

0 = Clocks are referenced to the input on pin XTALI (crystal or master clock input).

Sample clock frequency is defined by Control Register Address 20 and Bit C2X8/7.

Sample clock phase may be shifted by Control Register Address 21.

Bit clock frequency is defined by bits C2M7:0 and C2P200.

Bit C2VID is ignored.

1 = Clocks are referenced to the input on pin SYNC2 (Sync 2 Clock Input).

Sample clock frequency is defined by C2VID and C2M7:0.

Sample clock phase is locked to SYNC2 and cannot be shifted.

Bit clock frequency is defined by bits C2M7:0 and C2P200 unless in Video Lock Mode (C2VID set to “1”) where the Bit clocks are not produced.

Control Register Addresses 17, 18 and the C2X8/7 bit are ignored.

C2VID Clock Generator 2 Video Lock Mode. This bit is used to select between lock modes when the Clock Generator 2 is referenced to SYNC2 (C2REF set to “1”). This bit should be reset to “0” if C2REF is reset to “0.” When reset to “0,” Clock Generator 2 is in *normal* lock mode where the Conversion clock will be frequency and phase locked to SYNC2, and the Bit clock frequency is chosen using bits C2M7:0 and C2P200. When set to “1,” Clock Generator 2 is in *video* lock mode, where the Conversion clock frequency is selected using bits C2M7:0, and a Bit clock is not produced.

C2PLLG Clock Generator 2 PLL Loop Gain Select. If reset to “0,” this bit selects finite PLL loop gain, and if set to “1,” this bit selects infinite PLL loop gain. This bit should nominally be reset to “0.” Setting it to “1” may enhance the PLL’s ability to lock to certain SYNC2 inputs, but it may also increase conversion noise.

C2P200 Clock Generator 2 Bit Clock +200 Frequency Modifier. When set to “1,” the Bit clock driven out of pin BIT2 will have a frequency that is 200 Hertz greater than the frequency selected through bit C2M7:0. This bit is ignored when in Video Lock Mode (C2VID set to “1”). C2P200 only modifies the bit clock driven on the BIT2 pin.

C2X8/7 Clock Generator 2 Conversion Clock 8/7 Frequency Modifier. When set to “1,” the Conversion clock frequency generated will be 8/7 times the value programmed in Control Register Address 20. This bit is ignored when clocks are referenced to SYNC2 (C2REF set to “1”).

C2C128 Clock Generator 2 Conversion Clock Pin (CONV2) Frequency Select. When set to “1,” the frequency driven on to the CONV2 pin will be 128 times the conversion rate. When reset to “0,” the frequency driven on to the CONV2 pin will be the same as the conversion rate. C2C128 only modifies the clock frequency driven on the CONV2 pin.

res Reserved for future expansion. To ensure future compatibility, write “0” to all reserved bits.

C2M7:0 Clock Generator 2 Clock Rate Modifiers.

When not in Video Lock Mode (C2REF and C2VID are not both set to “1”):

Bits C2M7:0 select the Bit clock rate which will be driven out on pin BIT2. Using the following table, the least significant four bits (C2M3:0) are programmed to the desired Bit clock rate, and the most significant four bits

(C2M7:4) must be programmed to the Conversion clock rate established using Control Register Address 20 and the C2X8/7 bit. If the actual Conversion clock differs from the value selected by C2M7:4, then the resultant Bit clock will be different from the rate selected by the ratio of the C2M7:4 selected rate to the Control Register Address 20 plus the C2X8/7 bit actual rate.

C2M3:0	Bit Clock Frequency*	C2M7:4	Conversion (Sample) Rate
0000	2,400 Hertz	0000	7,200 Hertz
0001	4,800	0001	8,400
0010	7,200	0010	9,000
0011	9,600	0011	9,600
0100	12,000	0100	11,200
0101	14,400	0101	12,000
0110	16,800	0110	12,800
0111	19,200	0111	7,200 × 8/7
1000	21,600	1000	9,000 × 8/7
1001	24,000	1001	9,600 × 8/7
1010	26,400	1010	12,000 × 8/7
1011	28,800	1011	Reserved
1100	Reserved	1100	Reserved
1101	Reserved	1101	Reserved
1110	Reserved	1110	Reserved
1111	See Below	1111	See Below

*Bit clock frequencies listed will be increased by 200 Hz if C2P200 is set to "1."

When C2M7:4 is programmed to "1111" and C2M3:0 is programmed to "1111," the Bit clock rate will be 128 times the Conversion rate.

When in Video Lock Mode (C2REF and C2VID are both set to "1"):

Bits C2M7:0 select the Conversion clock rate. The most significant bit (C2M7) must be set to indicate the type of video lock, either NTSC or PAL. For an NTSC lock, C2M7 must be reset to "0," and the SYNC2 pin must receive the NTSC sync frequency (525 lines/frame × 30 Hz × 1000/1001 frame rate ≈ 15.734 kHz). For a PAL lock, C2M7 must be set to "1," and the SYNC2 pin must receive the PAL sync frequency (625 lines/frame × 25 Hz frame rate ≈ 15.625 kHz). The next three most significant bits (C2M6:4) select a desired *base* Conversion clock rate, and the least significant four bits (C2M3:0) select a *divisor*. The Conversion clock created by Clock Generator 2 will be the *base* divided by the *divisor*. The following tables list the possible choices for base and divisor.

NTSC		(C2M7 = "0"):					
		Base Frequency In Hz (C2M6:4)					
Divisor	(C2M3:0)	48,000	32,000	44,100	44,100 × 2/3	48,000*	44,056
1	(0000)	Yes	Yes	Yes	Yes	Yes	Yes
2	(0001)	Yes	Yes	Yes	Yes	Yes	Yes
3	(0010)	Yes	No	Yes	No	Yes	Yes
4	(0011)	Yes	Yes	Yes	Yes	Yes	Yes
5	(0100)	Yes	Yes	Yes	Yes	Yes	Yes
6	(0101)	Yes	No	Yes	No	Yes	Yes
7	(0110)	No	No	Yes	No	Yes	Yes
8	(0111)	Yes	No	Yes	No	Yes	Yes

*When C2M6:4 = "100," base frequency is 48,000 Hz only if NTSC sync rate is increased by 1001/1000, or is exactly 15.750 kHz.

PAL		(C2M7 = "1"):			
		Base Frequency In Hz (C2M6:4)			
Divisor	(C2M3:0)	48,000	32,000	44,100	44,100 × 2/3
1	(0000)	Yes	Yes	Yes	Yes
2	(0001)	Yes	Yes	Yes	Yes
3	(0010)	Yes	No	Yes	No
4	(0011)	Yes	Yes	Yes	Yes
5	(0100)	Yes	Yes	Yes	Yes
6	(0101)	Yes	No	Yes	No
7	(0110)	Yes	No	Yes	No
8	(0111)	Yes	No	Yes	No

Initial default state after reset: 0000 0000 1111 1111 (00FF hex). Cleared to default and cannot be written to when: the $\overline{\text{RESET}}$ pin is asserted LO; or when the $\overline{\text{PWRDWN}}$ pin is asserted LO.

AD1843

Address 20		Clock Generator 2 Control—Sample Rate					
Data 15	Data 14	Data 13	Data 12	Data 11	Data 10	Data 9	Data 8
C2C15	C2C14	C2C13	C2C12	C2C11	C2C10	C2C9	C2C8
Data 7	Data 6	Data 5	Data 4	Data 3	Data 2	Data 1	Data 0
C2C7	C2C6	C2C5	C2C4	C2C3	C2C2	C2C1	C2C0

C2C15:0 Clock Generator 2 Conversion (Sample) Rate Select. Defines the conversion rate produced by Clock Generator 2 when not referenced to the SYNC2 pin (Control Register Address 19 Bit 15 [C2REF]). One LSB represents exactly one Hertz, assuming a 24.576 MHz clock input on the XTALI pin. Usable range is 4 kHz (0x0FA0) to 54 kHz (0xD2F0).
Initial default state after reset: 1011 1011 1000 0000 (BB80 hex), which is 48 kHz, assuming a 24.576 MHz clock input on the XTALI pin. Cleared to default and cannot be written to when: the $\overline{\text{RESET}}$ pin is asserted LO; or when the $\overline{\text{PWRDWN}}$ pin is asserted LO.

Address 21		Clock Generator 2 Control—Sample Phase Shift					
Data 15	Data 14	Data 13	Data 12	Data 11	Data 10	Data 9	Data 8
res	res	res	res	res	res	res	C2PD
Data 7	Data 6	Data 5	Data 4	Data 3	Data 2	Data 1	Data 0
C2P7	C2P6	C2P5	C2P4	C2P3	C2P2	C2P1	C2P0

C2PD Clock Generator 2 Phase Shift Direction. This bit controls the direction of sample clock phase shift.
0 = Phase Advance
1 = Phase Retard

C2P7:0 Clock Generator 2 Phase Shift Magnitude. These bits control the magnitude of sample clock phase shift. One LSB represents exactly 0.12 degrees. LSBs are processed and decremented at a rate of 3.072 MHz (assuming a 24.576 MHz clock input on the XTALI pin). When this register is read, it indicates any phase advance/retard remaining to be processed as of the beginning of slot 0 if bus master, or when TSI was received if bus slave. This register may be overwritten even if all previously programmed phase advance/retard has not been processed. When written, the contents of this register (just prior to the write) are transmitted during slot 1 of the following frame (as with all Control Register writes).

res Reserved for future expansion. To ensure future compatibility, write “0” to all reserved bits.
Initial default state after reset: 0000 0000 0000 0000 (0000 hex). Cleared to default and cannot be written to when: the $\overline{\text{RESET}}$ pin is asserted LO; when the $\overline{\text{PWRDWN}}$ pin is asserted LO; or when the G2EN bit in Control Register Address 28 is reset to “0” (clock generator 2 disabled).

Address 22		Clock Generator 3 Control—Mode					
Data 15	Data 14	Data 13	Data 12	Data 11	Data 10	Data 9	Data 8
C3REF	C3VID	C3PLLG	C3P200	C3X8/7	C3C128	res	res
Data 7	Data 6	Data 5	Data 4	Data 3	Data 2	Data 1	Data 0
C3M7	C3M6	C3M5	C3M4	C3M3	C3M2	C3M1	C3M0

C3REF Clock Generator 3 Reference Select. Selects the fundamental clock reference used by Clock Generator 3 to synthesize its “Conversion” (sample) and “Bit” clock rates.

0 = Clocks are referenced to the input on pin XTALI (crystal or master clock input).

Sample clock frequency is defined by Control Register Address 23 and Bit C3X8/7.

Sample clock phase may be shifted by Control Register Address 24.

Bit clock frequency is defined by bits C3M7:0 and C3P200.

Bit C3VID is ignored.

1 = Clocks are referenced to the input on pin SYNC3 (Sync 3 Clock Input).

Sample clock frequency is defined by C3VID and C3M7:0.

Sample clock phase is locked to SYNC3 and cannot be shifted.

Bit clock frequency is defined by bits C3M7:0 and C3P200 unless in Video Lock Mode (C3VID set to "1") where the Bit clocks are not produced.

Control Register Addresses 23, 24 and the C3X8/7 bits are ignored.

C3VID	Clock Generator 3 Video Lock Mode. This bit is used to select between lock modes when the Clock Generator 3 is referenced to SYNC3 (C3REF set to "1"). This bit should be reset to "0" if C3REF is reset to "0." When reset to "0," Clock Generator 3 is in <i>normal</i> lock mode where the Conversion clock will be frequency and phase locked to SYNC3, and the Bit clock frequency is chosen using bits C3M7:0 and C3P200. When set to "1," Clock Generator 3 is in <i>video</i> lock mode, where the Conversion clock frequency is selected using bits C3M7:0, and a Bit clock is not produced.
C3PLLG	Clock Generator 3 PLL Loop Gain Select. If reset to "0," this bit selects finite PLL loop gain, and if set to "1," this bit selects infinite PLL loop gain. This bit should nominally be reset to "0." Setting it to "1" may enhance the PLL's ability to lock to certain SYNC3 inputs, but it may also increase conversion noise.
C3P200	Clock Generator 3 Bit Clock +200 Frequency Modifier. When set to "1," the Bit clock driven out of pin BIT3 will have a frequency that is 200 Hertz greater than the frequency selected through bit C3M7:0. This bit is ignored when in Video Lock Mode (C3VID set to "1"). C3P200 only modifies the bit clock driven on the BIT3 pin.
C3X8/7	Clock Generator 3 Conversion Clock 8/7 Frequency Modifier. When set to "1," the Conversion clock frequency generated will be 8/7 times the value programmed in Control Register Address 23. This bit is ignored when clocks are referenced to SYNC3 (C3REF set to "1").
C3C128	Clock Generator 3 Conversion Clock Pin (CONV3) Frequency Select. When set to "1," the frequency driven on to the CONV3 pin will be 128 times the conversion rate. When reset to "0," the frequency driven on to the CONV3 pin will be the same as the conversion rate. C3C128 only modifies the clock frequency driven on the CONV3 pin.
res	Reserved for future expansion. To ensure future compatibility, write "0" to all reserved bits.
C3M7:0	Clock Generator 3 Clock Rate Modifiers.

When not in Video Lock Mode (C3REF and C3VID are not both set to "1"):

Bits C3M7:0 select the Bit clock rate which will be driven out on pin BIT3. Using the following table, the least significant four bits (C3M3:0) are programmed to the desired Bit clock rate, and the most significant four bits (C3M7:4) must be programmed to the Conversion clock rate established using Control Register Address 23 and the C3X8/7 bit. If the actual Conversion clock differs from the value selected by C3M7:4, then the resultant Bit clock will be different from the rate selected by the ratio of the C3M7:4 selected rate to the Control Register Address 23 plus the C3X8/7 bit actual rate.

C3M3:0	Bit Clock Frequency*	C3M7:4	Conversion (Sample) Rate
0000	2,400 Hertz	0000	7,200 Hertz
0001	4,800	0001	8,400
0010	7,200	0010	9,000
0011	9,600	0011	9,600
0100	12,000	0100	11,200
0101	14,400	0101	12,000
0110	16,800	0110	12,800
0111	19,200	0111	7,200 × 8/7
1000	21,600	1000	9,000 × 8/7
1001	24,000	1001	9,600 × 8/7
1010	26,400	1010	12,000 × 8/7
1011	28,800	1011	Reserved
1100	Reserved	1100	Reserved
1101	Reserved	1101	Reserved
1110	Reserved	1110	Reserved
1111	See Below	1111	See Below

*Bit clock frequencies listed will be increased by 200 Hz if C3P200 is set to "1."

When C3M7:4 is programmed to "1111" and C3M3:0 is programmed to "1111," the Bit clock rate will be 128 times the Conversion rate.

AD1843

When in Video Lock Mode (C3REF and C3VID are both set to “1”):

Bits C3M7:0 select the Conversion clock rate. The most significant bit (C3M7) must be set to indicate the type of video lock, either NTSC or PAL. For an NTSC lock, C3M7 must be reset to “0,” and the SYNC3 pin must receive the NTSC sync frequency (525 lines/frame × 30 Hz × 1000/1001 frame rate ≈ 15.734 kHz). For a PAL lock, C3M7 must be set to “1,” and the SYNC3 pin must receive the PAL sync frequency (625 lines/frame × 25 Hz frame rate ≈ 15.625 kHz). The next three most significant bits (C3M6:4) select a desired *base* Conversion clock rate, and the least significant four bits (C3M3:0) select a *divisor*. The Conversion clock created by Clock Generator 3 will be the *base* divided by the *divisor*. The following tables list the possible choices for base and divisor.

NTSC		(C3M7 = “0”): <u>Base Frequency In Hz (C3M6:4)</u>					
<u>Divisor</u>	<u>(C3M3:0)</u>	48,000 (000)	32,000 (001)	44,100 (010)	44,100 × 2/3 (011)	48,000* (100)	44,056 (101)
1	(0000)	Yes	Yes	Yes	Yes	Yes	Yes
2	(0001)	Yes	Yes	Yes	Yes	Yes	Yes
3	(0010)	Yes	No	Yes	No	Yes	Yes
4	(0011)	Yes	Yes	Yes	Yes	Yes	Yes
5	(0100)	Yes	Yes	Yes	Yes	Yes	Yes
6	(0101)	Yes	No	Yes	No	Yes	Yes
7	(0110)	No	No	Yes	No	Yes	Yes
8	(0111)	Yes	No	Yes	No	Yes	Yes

*When C3M6:4 = “100,” base frequency is 48,000 Hz only if NTSC sync rate is increased by 1001/1000, or is exactly 15.570 kHz.

PAL		(C3M7 = “1”): <u>Base Frequency In Hz (C3M6:4)</u>			
<u>Divisor</u>	<u>(C3M3:0)</u>	48,000 (000)	32,000 (001)	44,100 (010)	44,100 × 2/3 (011)
1	(0000)	Yes	Yes	Yes	Yes
2	(0001)	Yes	Yes	Yes	Yes
3	(0010)	Yes	No	Yes	No
4	(0011)	Yes	Yes	Yes	Yes
5	(0100)	Yes	Yes	Yes	Yes
6	(0101)	Yes	No	Yes	No
7	(0110)	Yes	No	Yes	No
8	(0111)	Yes	No	Yes	No

Initial default state after reset: 0000 0000 1111 1111 (00FF hex). Cleared to default and cannot be written to when: the $\overline{\text{RESET}}$ pin is asserted LO; or when the $\overline{\text{PWRDWN}}$ pin is asserted LO.

Address 23		Clock Generator 3 Control—Sample Rate							
Data 15	Data 14	Data 13	Data 12	Data 11	Data 10	Data 9	Data 8	Data 7	Data 6
C3C15	C3C14	C3C13	C3C12	C3C11	C3C10	C3C9	C3C8	Data 5	Data 4
Data 3	Data 2	Data 1	Data 0	C3C7	C3C6	C3C5	C3C4	C3C3	C3C2
C3C1	C3C0								

C3C15:0 Clock Generator 3 Conversion (Sample) Rate Select. Defines the conversion rate produced by Clock Generator 3 when not referenced to the SYNC3 pin (Control Register Address 22 Bit 15 [C3REF]). One LSB represents exactly one Hertz, assuming a 24.576 MHz clock input on the XTALI pin. Usable range is 4 kHz (0x0FA0) to 54 kHz (0xD2F0).

Initial default state after reset: 1011 1011 1000 0000 (BB80 hex), which is 48 kHz, assuming a 24.576 MHz clock input on the XTALI pin. Cleared to default and cannot be written to when: the $\overline{\text{RESET}}$ pin is asserted LO; or when the $\overline{\text{PWRDWN}}$ pin is asserted LO.

Address 24		Clock Generator 3 Control—Sample Phase Shift						
Data 15	Data 14	Data 13	Data 12	Data 11	Data 10	Data 9	Data 8	
res	res	res	res	res	res	res	C3PD	
Data 7	Data 6	Data 5	Data 4	Data 3	Data 2	Data 1	Data 0	
C3P7	C3P6	C3P5	C3P4	C3P3	C3P2	C3P1	C3P0	

- C3PD** Clock Generator 3 Phase Shift Direction. This bit controls the direction of sample clock phase shift.
0 = Phase Advance
1 = Phase Retard
- C3P7:0** Clock Generator 3 Phase Shift Magnitude. These bits control the magnitude of sample clock phase shift. One LSB represents exactly 0.12 degrees. LSBs are processed and decremented at a rate of 3.072 MHz (assuming a 24.576 MHz clock input on the XTALI pin). When this register is read, it indicates any phase advance/retard remaining to be processed as of the beginning of slot 0 if bus master, or when TSI was received if bus slave. This register may be overwritten even if all previously programmed phase advance/retard has not been processed. When written, the contents of this register (just prior to the write) are transmitted during slot 1 of the following frame (as with all Control Register writes).
- res** Reserved for future expansion. To ensure future compatibility, write “0” to all reserved bits.
 Initial default state after reset: 0000 0000 0000 0000 (0000 hex). Cleared to default and cannot be written to when: the $\overline{\text{RESET}}$ pin is asserted LO; when the $\overline{\text{PWRDWN}}$ pin is asserted LO; or when the G3EN bit in Control Register Address 28 is reset to “0” (clock generator 3 disabled).

Address 25		Codec Configuration—Digital Filter and Mode Select						
Data 15	Data 14	Data 13	Data 12	Data 11	Data 10	Data 9	Data 8	
DRSFLT	DAMIX	res	res	res	res	DA2FLT	DA1FLT	
Data 7	Data 6	Data 5	Data 4	Data 3	Data 2	Data 1	Data 0	
DAADR1	DAADR0	DAADL1	DAADL0	res	res	ADRFLT	ADLFLT	

Restrictions: Modem filter should not be selected when channel sample rate is above 24 kHz.

- DRSFLT** Digital Resampler Filter Mode. DAC2 is sacrificed so that the remaining four channels (left ADC, right ADC, left and right DAC1) have sufficient resources to realize the more stringent resampling filter requirements. See below for filter specifications. (Note: Digital resampling can be done without using the resampling filters but performance is not as optimal.) This bit can be altered only if all channels (DAC1, DAC2, ADL, and ADR) are powered down. Note that this bit enables the digital resampler filters, but does not enable the digital resampler data pathways. Use the DAADR1:0 and DAADL1:0 bits to enable the resampler data pathways.
0 = Audio/Modem Filter Modes (Defined by DA1FLT, DA2FLT, ADLFLT and ADRFLT)
1 = Digital Resampler Filter Mode (DA1FLT, DA2FLT, ADLFLT and ADRFLT filter selections are ignored).
- DAMIX** DAC Digital Mix Enable. When set to “1,” DAC1 and DAC2 are mixed at the output of the digital interpolation filter. Left and right channels are still separated, but DAC1 and DAC2 outputs are identical. This bit can be altered only if both DAC1 and DAC2 are powered down.
0 = Digital Mix Disabled
1 = Digital Mix Enabled
- DA2FLT** DAC2 (Left and Right Channels) Digital Filter Select and Analog Output Swing Select. Digital filter selected is overridden when DRSFLT is set to “1.” See below for filter specifications. This bit can be altered only if DAC2 is powered down.
0 = Digital Audio Filter. Nominal analog swing is 2.000 V p-p when output level is +0.0 dB (see Control Register Address 10).
1 = Digital Modem Filter. Nominal analog swing is 3.156 V p-p when output level is +4.5 dB (see Control Register Address 10).

AD1843

- DA1FLT** DAC1 (Left and Right Channels) Digital Filter Select. This bit is overridden when DRSFLT is set to “1.” See below for filter specifications. This bit can be altered only if DAC1 is powered down. Unlike DA2FLT, this bit does not control the analog output swing of DAC1, which is fixed at 2.000 V p-p when the output level is set to 0 dB by Control Register Address 9.
0 = Digital Audio Filter
1 = Digital Modem Filter
- DAADR1:0** Digital ADC Right Channel Source Select.
00 = Input from Analog: ADC Right Channel (Normal Operation)
01 = Reserved
10 = Input from Digital: DAC1 Right Channel (Digital Resampler)
11 = Input from Digital: DAC2 Right Channel (Digital Resampler)
- DAADL1:0** Digital ADC Left Channel Source Select.
00 = Input from Analog: ADC Left Channel (Normal Operation)
01 = Reserved
10 = Input from Digital: DAC1 Left Channel (Digital Resampler)
11 = Input from Digital: DAC2 Left Channel (Digital Resampler)
- ADRFLT** ADC Right Channel Digital Filter Select and Analog Input Full Scale Mapping Select. Digital filter selected is overridden when DRSFLT is set to “1.” See below for filter specifications. This bit can be altered only if the ADC right channel is powered down.
0 = Digital Audio Filter. 2.800 V p-p analog input maps to $\pm 2^{15}$ when gain is set to 0.0 dB (see Control Register Address 2).
1 = Digital Modem Filter. 3.156 V p-p analog input maps to $\pm 2^{15}$ when gain is set to 0.0 dB (see Control Register Address 2).
- ADLFLT** ADC Left Channel Digital Filter Select and Analog Input Full Scale Mapping Select. Digital filter selected is overridden when DRSFLT is set to “1.” See below for filter specifications. This bit can be altered only if the ADC left channel is powered down.
0 = Digital Audio Filter. 2.800 V p-p analog input maps to $\pm 2^{15}$ when gain is set to 0.0 dB (see Control Register Address 2).
1 = Digital Modem Filter. 3.156 V p-p analog input maps to $\pm 2^{15}$ when gain is set to 0.0 dB (see Control Register Address 2).

res Reserved for future expansion. To ensure future compatibility, write “0” to all reserved bits.
 Initial default state after reset: 0000 0000 0000 0000 (0000 hex). Cleared to default and cannot be written to when: the $\overline{\text{RESET}}$ pin is asserted LO; when the $\overline{\text{PWRDWN}}$ pin is asserted LO; or when the PDNO bit in Control Register Address 0 is set to “1” (all conversions disabled).

The table below lists the single path (DAC or ADC only) filter characteristics of the “Audio,” “Modem,” and “Resampler” digital filters. Passband ripple and group delay must be doubled if the DAC is routed back through the ADC for digital resampling. For further information, see the “Filter Selection” section and the filter frequency response plots, Figures 34 through 36.

Filter	Passband Ripple	Edge	Stopband Ripple	Edge	Linear Group Delay
Audio	-0.016 dB	$0.400 \times F_S$	< -91.8 dB	$0.600 \times F_S$	< $15/F_S$
Modem	-0.220 dB	$0.442 \times F_S$	< -75.7 dB	$0.542 \times F_S$	< $19/F_S$
Resampler	-0.035 dB	$0.400 \times F_S$	< -92.2 dB	$0.500 \times F_S$	< $25/F_S$

F_S is the conversion (sample) rate.

Address 26								Codec Configuration—Serial Interface							
Data 15		Data 14		Data 13		Data 12		Data 11		Data 10		Data 9		Data 8	
DA2SM		DA1SM		res		res		DA2F1		DA2F0		DA1F1		DA1F0	
Data 7		Data 6		Data 5		Data 4		Data 3		Data 2		Data 1		Data 0	
SCF		FRS		FRST		ADTLK		ADRF1		ADRF0		ADLF1		ADLF0	

DA2SM	DAC2 Stereo/Mono Mode Select. When in stereo mode, data transmitted to the AD1843 during slot 4 is used by DAC2 left and data transmitted to the AD1843 during slot 5 is used by DAC2 right. When in mono mode, data transmitted to the AD1843 during slot 4 is used by both DAC2 left and right, and data transmitted to the AD1843 during slot 5 is ignored. (Note: slot 0 is assumed to be the first slot.) 0 = Stereo Mode 1 = Mono Mode
DA1SM	DAC1 Stereo/Mono Mode Select. When in stereo mode, data transmitted to the AD1843 during slot 2 is used by DAC1 left and data transmitted to the AD1843 during slot 3 is used by DAC1 right. When in mono mode, data transmitted to the AD1843 during slot 2 is used by both DAC1 left and right, and data transmitted to the AD1843 during slot 3 is ignored. (Note: slot 0 is assumed to be the first slot.) 0 = Stereo Mode 1 = Mono Mode
DA2F1:0	DAC2 (Left and Right Channels) Data Format Select. 00 = 8-bit Unsigned Linear PCM 01 = 16-bit Signed Linear PCM 10 = 8-bit μ -Law Companded 11 = 8-bit A-Law Companded
DA1F1:0	DAC1 (Left and Right Channels) Data Format Select. 00 = 8-bit Unsigned Linear PCM 01 = 16-bit Signed Linear PCM 10 = 8-bit μ -Law Companded 11 = 8-bit A-Law Companded
SCF	SCLK Frequency Select. Changes to this bit do not take effect until shortly after the sixth slot (the final slot owned) is completed. Relevant when the AD1843 is in Master Mode only. 0 = 12.288 MHz 1 = 16.384 MHz
FRS	Frame Size Select. Selects the number of slots per frame. Changes to this bit do not take effect until the time specified by the FRST bit. 0 = 32 Slots per Frame 1 = 16 Slots per Frame
FRST	Frame Size Change Timing. Selects the point in time when FRS takes effect. 0 = Frame Size Changes Once the Current Frame is Complete 1 = Frame Size Changes Immediately, Beginning with the Current Frame
ADTLK	ADC Transmit Lock Mode Select. When this bit is set to "1," ADC transmit lock mode is entered. In this mode, left and right ADC samples are transmitted during a frame only if both left and right samples are ready to be transmitted. When not in ADC transmit lock mode, left and right samples are transmitted as they individually become available. Note that even if left and right ADCs are programmed to the same sample rate, unless the AD1843 is in transmit lock mode, ADC samples will not necessarily be transmitted paired together in a TDM frame. This bit should be set to "1" only if both ADCs are powered down and only if both ADCs will be programmed to the sample rate once they are enabled. This bit may be reset to "0" at any time. While in ADC transmit lock mode, both ADCs must be enabled and disabled simultaneously (write to Control Register Address 27 must set ADLEN and ADREN both to "0" or to "1"). 0 = ADC Transmit Lock Mode Disabled 1 = ADC Transmit Lock Mode Enabled
ADRF1:0	ADC Right Channel Data Format Select. 00 = 8-bit Unsigned Linear PCM 01 = 16-bit Signed Linear PCM 10 = 8-bit μ -Law Companded 11 = 8-bit A-Law Companded
ADLF1:0	ADC Left Channel Data Format Select. 00 = 8-bit Unsigned Linear PCM 01 = 16-bit Signed Linear PCM 10 = 8-bit μ -Law Companded 11 = 8-bit A-Law Companded
res	Reserved for future expansion. To ensure future compatibility, write "0" to all reserved bits. Initial default state after reset: 0000 0000 0000 0000 (0000 hex). Cleared to default and cannot be written to when: the RESET pin is asserted LO; or when the PWRDWN pin is asserted LO.

AD1843

Address 27								Codec Configuration—Channel Power Down							
Data 15		Data 14		Data 13		Data 12		Data 11		Data 10		Data 9		Data 8	
DFREE		res		res		DDMEN		res		res		DA2EN		DA1EN	
Data 7		Data 6		Data 5		Data 4		Data 3		Data 2		Data 1		Data 0	
ANAEN		HPEN		res		AAMEN		res		res		ADREN		ADLEN	

- DFREE** Digital Resource Free. When set to “1,” this bit reduces the level of power down normally achieved by asserting the power down bits in this Control Register. However, it allows the digital resources of channels powered down to be partially transferred to the remaining enabled channels and thus permits conversion rates higher than the 48 kHz nominal maximum. See the “Supported Conversion Rates” section.
0 = Power Down of Digital Resources is Complete
1 = Power Down of Digital Resources is Incomplete, Freeing Transferable Resources to Enabled Channels
- DDMEN** DAC2 to DAC1 Mix Enable/Power Down. When reset to “0,” Control Register Address 3 is cleared to its default and cannot be written.
0 = Mix is Powered Down
1 = Mix is Enabled
- DA2EN** DAC2 (Left and Right Channels) Enable/Power Down. When this bit is reset to “0,” DAC2 is powered down and serial interface requests for samples (see slot 0) will cease immediately. When this bit is set to “1,” DAC2 is enabled and requests for samples resume on the next frame. Conversions will not actually begin until the first rising edge of the conversion clock (CONV pin) after the sixth rising edge of frame sync (SDFS pin) after this bit is set to “1.” This delay allows the four word stereo input buffer for DAC2 to be filled before conversions begin and allows the serial interface to synchronize with the conversion clock, which is potentially already running. This delay also allows DACs on multiple AD1843s sharing the same frame sync to begin conversions synchronously, providing they are enabled at any time during the same frame. When this bit is reset to “0,” Control Register Address 10, which is the Output Level Control Register for DAC2, is cleared to default and cannot be written.
0 = DAC2 is Powered Down, Control Register Address 10 (DAC2 Output Level Control) is Cleared
1 = DAC2 is Enabled
- DA1EN** DAC1 (Left and Right Channels) Enable/Power Down. When this bit is reset to “0,” DAC1 is powered down and serial interface requests for samples (see slot 0) will cease immediately. When this bit is set to “1,” DAC1 is enabled and requests for samples resume on the next frame. Conversions will not actually begin until the first rising edge of the conversion clock (CONV pin) after the sixth rising edge of frame sync (SDFS pin) after this bit is set to “1.” This delay allows the four word stereo input buffer for DAC1 to be filled before conversions begin and allows the serial interface to synchronize with the conversion clock, which is potentially already running. This delay also allows DACs on multiple AD1843s sharing the same frame sync to begin conversions synchronously, providing they are enabled at any time during the same frame. When this bit is reset to “0,” Control Register Address 9, which is the Output Level Control Register for DAC1, is cleared to default and cannot be written.
0 = DAC1 is Powered Down, Control Register Address 9 (DAC1 Output Level Control) is Cleared
1 = DAC1 is Enabled
- ANAEN** Analog Channel Enable/Power Down. If this bit is reset to “0,” all analog conversion circuitry (related to bits DA1EN, DA2EN, ADLEN, ADREN, DDMEN and AAMEN) will be powered down. When reset to “0,” the only conversion channels usable (but must be enabled separately) are the digital resampling paths. Since resetting this bit to “0” powers down the analog ADC, DAC1, DAC2 and analog mixers, their related output level Control Register Addresses 4 through 7, half of 8, 9 and 10 are cleared and cannot be written while ANAEN remains “0.”
0 = Analog Channels are Powered Down, Control Register Addresses 4 through 7, half of 8, 9 and 10 are Cleared to Default (Digital to Digital Still Possible)
1 = Analog DAC and ADC Paths are Controlled by DA1EN, DA2EN, ADLEN, ADREN, DDMEN and AAMEN
- HPEN** Headphone Enable/Power Down.
0 = Headphone Output is Powered Down
1 = Headphone Output is Enabled
- AAMEN** Analog Input to Analog Output Mix Enable/Power Down. When reset to “0,” Control Register Addresses 4 - 7 and half of Control Register Address 8 are cleared and cannot be written.
0 = Mix is Powered Down
1 = Mix is Enabled

ADREN ADC Right Channel Enable/Power Down. When this bit is reset to “0,” the right ADC channel is powered down and serial interface sample output will cease after the current frame. When this bit is set to “1,” the right ADC channel is enabled and sampling of analog input will begin on the first rising edge of the conversion clock (CONV pin) after the sixth rising edge of frame sync (SDFS pin). This delay allows the ADC startup to be similar to the DAC startup, and allows some time for stale ADC data inside the AD1843 to be cleared. It also allows the serial interface to synchronize with the conversion clock, which is potentially already running. Multiple ADCs on multiple AD1843s which share the same frame sync will be synchronously started if they are enabled at any time during the same frame.

0 = ADC Right Channel is Powered Down
1 = ADC Right Channel is Enabled

ADLEN ADC Left Channel Enable/Power Down. When this bit is reset to “0,” the left ADC channel is powered down and serial interface sample output will cease after the current frame. When this bit is set to “1,” the left ADC channel is enabled and sampling of analog input will begin on the first rising edge of the conversion clock (CONV pin) after the sixth rising edge of frame sync (SDFS pin). This delay allows the ADC startup to be similar to the DAC startup, and allows some time for stale ADC data inside the AD1843 to be cleared. It also allows the serial interface to synchronize with the conversion clock, which is potentially already running. Multiple ADCs on multiple AD1843s which share the same frame sync will be synchronously started if they are enabled at any time during the same frame.

0 = ADC Left Channel is Powered Down
1 = ADC Left Channel is Enabled

res Reserved for future expansion. To ensure future compatibility, write “0” to all reserved bits.

Initial default state after reset: 0000 0000 1100 0000 (00C0 hex). Cleared to default and cannot be written to when: the $\overline{\text{RESET}}$ pin is asserted LO; when the $\overline{\text{PWRDWN}}$ pin is asserted LO; or when the PDNO bit in Control Register Address 0 is set to “1” (all conversions disabled).

Address 28								Codec Configuration—Fundamental Settings							
Data 15	Data 14	Data 13	Data 12	Data 11	Data 10	Data 9	Data 8	Data 7	Data 6	Data 5	Data 4	Data 3	Data 2	Data 1	Data 0
PDNI	ACEN	C3EN	C2EN	C1EN	ENCLKO	XCTL1	XCTL0	ENCV3	ENBT3	ENCV2	ENBT2	ENCV1	ENBT1	LINRS	LINLS

PDNI Converter Power Down. When set to “1,” this bit initiates the process of powering down all conversion channels, overriding the settings in Control Register Address 27. Unlike the individual power down bits in Control Register Address 27, asserting this bit allows the DAC and V_{REF} output pins to slowly decay to ground. Setting this bit to “1” results in lower power consumption than results from powering down all channels individually through Control Register Address 27, and also reduces speaker “click” if asserted before the power supply is removed. Power down is not complete until approximately 5 ms after this bit is set to “1.” During this time, the AD1843 still requires a clock input from XTALI for proper operation. When reset to “0,” this bit initiates the process of preparing the AD1843 for conversions after power down. Approximately 470 ms are necessary to exit power down. The power up/down status of the AD1843 may be monitored through the PDNO bit in Control Register Address 0. Asserting the power down pin ($\overline{\text{PWRDWN}}$) will result in an even greater degree of power down as it also powers down the serial interface and crystal oscillator. Once a power up or power down sequence has been initiated, its completion cannot be interrupted. Changes made to the state of PDNI (i.e., writes to PDNI) are ignored until a previously pending PDNI state change has been completely processed.

0 = Normal (Non-Power Down) Operation
1 = Initiate Power Down of All Conversion Channels

ACEN Autocalibration Enable. When set to “1,” autocalibration will occur each time power down is exited (PDNI is changed from a “1” to a “0”). Autocalibration increases the time required to exit power down by 4 ms (from 470 ms to 474 ms). When reset to “0,” autocalibration is disabled. This bit is set to “1” initially after reset and cannot be overwritten until after the AD1843 has come out of power down (PDNO bit in Control Register Address 0 reset to “0”) at least once. Note that an autocalibration cycle is always performed following a hardware reset (i.e., $\overline{\text{RESET}}$ pin asserted) or a hardware power down (i.e., $\overline{\text{PWRDWN}}$ pin asserted), regardless of the state of ACEN.

0 = Autocalibration Disabled
1 = Autocalibration Enabled, Initiated upon Exiting Power Down

C3EN Clock Generator 3 Enable/Power Down.

0 = Clock Generator 3 Powered Down
1 = Clock Generator 3 Enabled

AD1843

- C2EN** Clock Generator 2 Enable/Power Down.
0 = Clock Generator 2 Powered Down
1 = Clock Generator 2 Enabled
- C1EN** Clock Generator 1 Enable/Power Down.
0 = Clock Generator 1 Powered Down
1 = Clock Generator 1 Enabled
- ENCLKO** CLKOUT Pin Enable.
0 = Clock Output is Three-stated (Powered Down)
1 = Clock Output is Enabled
- XCTL1:0** External Control. The state of these independent bits is reflected on the respective XCTL1 and XCTL0 output pins.
0 = TTL Logic Level LO on XCTL1/XCTL0 pin
1 = TTL Logic Level HI on XCTL1/XCTL0 pin
- ENCV3** CONV3 Pin Enable.
0 = CONV3 is Three-stated (Powered Down)
1 = CONV3 is Enabled
- ENBT3** BIT3 Pin Enable.
0 = BIT3 is Three-stated (Powered Down)
1 = BIT3 is Enabled
- ENCV2** CONV2 Pin Enable.
0 = CONV2 is Three-stated (Powered Down)
1 = CONV2 is Enabled
- ENBT2** BIT2 Pin Enable.
0 = BIT2 is Three-stated (Powered Down)
1 = BIT2 is Enabled
- ENCV1** CONV1 Pin Enable.
0 = CONV1 is Three-stated (Powered Down)
1 = CONV1 is Enabled
- ENBT1** BIT1 Pin Enable.
0 = BIT1 is Three-stated (Powered Down)
1 = BIT1 is Enabled
- LINRSD** Line Input Right Channel Single-Ended or Differential Configuration.
0 = Right Channel Line Input is Single-Ended
1 = Right Channel Line Input is Differential
- LINLSD** Line Input Left Channel Single-Ended or Differential Configuration.
0 = Left Channel Line Input is Single-Ended
1 = Left Channel Line Input is Differential
- res** Reserved for future expansion. To ensure future compatibility, write “0” to all reserved bits.
 Initial default state after reset: 1100 0100 0000 0000 (C400 hex). Cleared to default and cannot be written to when: the $\overline{\text{RESET}}$ pin is asserted LO; or when the $\overline{\text{PWRDWN}}$ pin is asserted LO.

Address 29		Reserved for Future Expansion							
	Data 15	Data 14	Data 13	Data 12	Data 11	Data 10	Data 9	Data 8	
	res	res	res	res	res	res	res	res	
	Data 7	Data 6	Data 5	Data 4	Data 3	Data 2	Data 1	Data 0	
	res	res	res	res	res	res	res	res	

- res** Reserved for future expansion. To ensure future compatibility, write “0” to all reserved bits.
 Initial default state after reset: 0000 0000 0000 0000 (0000 hex). Cleared to default and cannot be written to when: the $\overline{\text{RESET}}$ pin is asserted LO; or when the $\overline{\text{PWRDWN}}$ pin is asserted LO.

Address 30								Reserved for Future Expansion							
Data 15		Data 14		Data 13		Data 12		Data 11		Data 10		Data 9		Data 8	
res		res		res		res		res		res		res		res	
Data 7		Data 6		Data 5		Data 4		Data 3		Data 2		Data 1		Data 0	
res		res		res		res		res		res		res		res	

res Reserved for future expansion. To ensure future compatibility, write “0” to all reserved bits.
 Initial default state after reset: 0000 0000 0000 0000 (0000 hex). Cleared to default and cannot be written to when: the **RESET** pin is asserted LO; or when the **PWRDWN** pin is asserted LO.

Address 31								Reserved for Future Expansion							
Data 15		Data 14		Data 13		Data 12		Data 11		Data 10		Data 9		Data 8	
res		res		res		res		res		res		res		res	
Data 7		Data 6		Data 5		Data 4		Data 3		Data 2		Data 1		Data 0	
res		res		res		res		res		res		res		res	

res Reserved for future expansion. To ensure future compatibility, write “0” to all reserved bits.
 Initial default state after reset: 0000 0000 0000 0000 (0000 hex). Cleared to default and cannot be written to when: the **RESET** pin is asserted LO; or when the **PWRDWN** pin is asserted LO.

BIT AND REGISTER MAPS

A map of all TDM time slot bit assignments and Control Register contents is summarized for reference as follows in Figure 14 and Figure 15:

INPUT SLOT	DATA 15	DATA 14	DATA 13	DATA 12	DATA 11	DATA 10	DATA 9	DATA 8	DATA 7	DATA 6	DATA 5	DATA 4	DATA 3	DATA 2	DATA 1	DATA 0
0 OR 16	RES	RES	RES	RES	RES	RES	DA2V	DA1V	R/W	RES	RES	IA4	IA3	IA2	IA1	IA0
1 OR 17	DATA 15	DATA 14	DATA 13	DATA 12	DATA 11	DATA 10	DATA 9	DATA 8	DATA 7	DATA 6	DATA 5	DATA 4	DATA 3	DATA 2	DATA 1	DATA 0
2 OR 18	DATA 15	DATA 14	DATA 13	DATA 12	DATA 11	DATA 10	DATA 9	DATA 8	DATA 7	DATA 6	DATA 5	DATA 4	DATA 3	DATA 2	DATA 1	DATA 0
3 OR 19	DATA 15	DATA 14	DATA 13	DATA 12	DATA 11	DATA 10	DATA 9	DATA 8	DATA 7	DATA 6	DATA 5	DATA 4	DATA 3	DATA 2	DATA 1	DATA 0
4 OR 20	DATA 15	DATA 14	DATA 13	DATA 12	DATA 11	DATA 10	DATA 9	DATA 8	DATA 7	DATA 6	DATA 5	DATA 4	DATA 3	DATA 2	DATA 1	DATA 0
5 OR 21	DATA 15	DATA 14	DATA 13	DATA 12	DATA 11	DATA 10	DATA 9	DATA 8	DATA 7	DATA 6	DATA 5	DATA 4	DATA 3	DATA 2	DATA 1	DATA 0

OUTPUT SLOT	DATA 15	DATA 14	DATA 13	DATA 12	DATA 11	DATA 10	DATA 9	DATA 8	DATA 7	DATA 6	DATA 5	DATA 4	DATA 3	DATA 2	DATA 1	DATA 0
0 OR 16	RES	RES	RES	RES	RES	RES	ADRV	ADLV	RES	RES	RES	RES	RES	RES	DA2RQ	DA1RQ
1 OR 17	DATA 15	DATA 14	DATA 13	DATA 12	DATA 11	DATA 10	DATA 9	DATA 8	DATA 7	DATA 6	DATA 5	DATA 4	DATA 3	DATA 2	DATA 1	DATA 0
2 OR 18	DATA 15	DATA 14	DATA 13	DATA 12	DATA 11	DATA 10	DATA 9	DATA 8	DATA 7	DATA 6	DATA 5	DATA 4	DATA 3	DATA 2	DATA 1	DATA 0
3 OR 19	DATA 15	DATA 14	DATA 13	DATA 12	DATA 11	DATA 10	DATA 9	DATA 8	DATA 7	DATA 6	DATA 5	DATA 4	DATA 3	DATA 2	DATA 1	DATA 0
4 OR 20	RES	RES	RES	RES	RES	RES	RES	RES	RES	RES	RES	RES	RES	RES	RES	RES
5 OR 21	RES	RES	RES	RES	RES	RES	RES	RES	RES	RES	RES	RES	RES	RES	RES	RES

Figure 14. AD1843 TDM Time Slot Bit Assignment Map

AD1843

CONTROL REG	DATA 15	DATA 14	DATA 13	DATA 12	DATA 11	DATA 10	DATA 9	DATA 8	DATA 7	DATA 6	DATA 5	DATA 4	DATA 3	DATA 2	DATA 1	DATA 0	
ADDRESS 0	INIT	PDNO	RES	RES	RES	RES	RES	RES	RES	RES	RES	RES	ID3	ID2	ID1	ID0	
ADDRESS 1	RES	RES	RES	RES	RES	RES	SU2	SU1	RES	RES	RES	RES	OVR1	OVR0	OV1	OV0	
ADDRESS 2	LSS2	LSS1	LSS0	LMGE	LIG3	LIG2	LIG1	LIG0	RSS2	RSS1	RSS0	RMGE	RIG3	RIG2	RIG1	RIG0	
ADDRESS 3	LD1MM	RES	RES	LD1M4	LD1M3	LD1M2	LD1M1	LD1M0	RD1MM	RES	RES	RD1M4	RD1M3	RD1M2	RD1M1	RD1M0	
ADDRESS 4	LX1MM	RES	RES	LX1M4	LX1M3	LX1M2	LX1M1	LX1M0	RX1MM	RES	RES	RX1M4	RX1M3	RX1M2	RX1M1	RX1M0	
ADDRESS 5	LX2MM	RES	RES	LX2M4	LX2M3	LX2M2	LX2M1	LX2M0	RX2MM	RES	RES	RX2M4	RX2M3	RX2M2	RX2M1	RX2M0	
ADDRESS 6	LX3MM	RES	RES	LX3M4	LX3M3	LX3M2	LX3M1	LX3M0	RX3MM	RES	RES	RX3M4	RX3M3	RX3M2	RX3M1	RX3M0	
ADDRESS 7	LMCMM	RES	RES	LMC4	LMC3	LMC2	LMC1	LMC0	RMCM	RES	RES	RMCM4	RMCM3	RMCM2	RMCM1	RMCM0	
ADDRESS 8	MNMM	RES	RES	MNM4	MNM3	MNM2	MNM1	MNM0	ALLMM	MNOM	HPOM	HPOS	SUMM	RES	DAC2T	DAC1T	
ADDRESS 9	LDA1GM	RES	LDA1G5	LDA1G4	LDA1G3	LDA1G2	LDA1G1	LDA1G0	RDA1GM	RES	RDA1G5	RDA1G4	RDA1G3	RDA1G2	RDA1G1	RDA1G0	
ADDRESS 10	LDA2GM	RES	LDA2G5	LDA2G4	LDA2G3	LDA2G2	LDA2G1	LDA2G0	RDA2GM	RES	RDA2G5	RDA2G4	RDA2G3	RDA2G2	RDA2G1	RDA2G0	
ADDRESS 11	LDA1AM	RES	LDA1A5	LDA1A4	LDA1A3	LDA1A2	LDA1A1	LDA1A0	RDA1AM	RES	RDA1A5	RDA1A4	RDA1A3	RDA1A2	RDA1A1	RDA1A0	
ADDRESS 12	LDA2AM	RES	LDA2A5	LDA2A4	LDA2A3	LDA2A2	LDA2A1	LDA2A0	RDA2AM	RES	RDA2A5	RDA2A4	RDA2A3	RDA2A2	RDA2A1	RDA2A0	
ADDRESS 13	LAD1MM	RES	LAD1M5	LAD1M4	LAD1M3	LAD1M2	LAD1M1	LAD1M0	RAD1MM	RES	RAD1M5	RAD1M4	RAD1M3	RAD1M2	RAD1M1	RAD1M0	
ADDRESS 14	LAD2MM	RES	LAD2M5	LAD2M4	LAD2M3	LAD2M2	LAD2M1	LAD2M0	RAD2MM	RES	RAD2M5	RAD2M4	RAD2M3	RAD2M2	RAD2M1	RAD2M0	
ADDRESS 15	RES	RES	RES	RES	DA2C1	DA2C0	DA1C1	DA1C0	RES	RES	RES	RES	ADRC1	ADRC0	ADLC1	ADLC0	
ADDRESS 16	C1REF	C1VID	C1PLLG	C1P200	C1X8/7	C1C128	RES	RES	C1M7	C1M6	C1M5	C1M4	C1M3	C1M2	C1M1	C1M0	
ADDRESS 17	C1C15	C1C14	C1C13	C1C12	C1C11	C1C10	C1C9	C1C8	C1C7	C1C6	C1C5	C1C4	C1C3	C1C2	C1C1	C1C0	
ADDRESS 18	RES	RES	RES	RES	RES	RES	RES	C1PD	C1P7	C1P6	C1P5	C1P4	C1P3	C1P2	C1P1	C1P0	
ADDRESS 19	C2REF	C2VID	C2PLLG	C2P200	C2X8/7	C2C128	RES	RES	C2M7	C2M6	C2M5	C2M4	C2M3	C2M2	C2M1	C2M0	
ADDRESS 20	C2C15	C2C14	C2C13	C2C12	C2C11	C2C10	C2C9	C2C8	C2C7	C2C6	C2C5	C2C4	C2C3	C2C2	C2C1	C2C0	
ADDRESS 21	RES	RES	RES	RES	RES	RES	RES	C2PD	C2P7	C2P6	C2P5	C2P4	C2P3	C2P2	C2P1	C2P0	
ADDRESS 22	C3REF	C3VID	C3PLLG	C3P200	C3X8/7	C3C128	RES	RES	C3M7	C3M6	C3M5	C3M4	C3M3	C3M2	C3M1	C3M0	
ADDRESS 23	C3C15	C3C14	C3C13	C3C12	C3C11	C3C10	C3C9	C3C8	C3C7	C3C6	C3C5	C3C4	C3C3	C3C2	C3C1	C3C0	
ADDRESS 24	RES	RES	RES	RES	RES	RES	RES	C3PD	C3P7	C3P6	C3P5	C3P4	C3P3	C3P2	C3P1	C3P0	
ADDRESS 25	DRSFLT	DAMIX	RES	RES	RES	RES	RES	DA2FLT	DA1FLT	DAADR1	DAADR0	DAADL1	DAADL0	RES	RES	ADRF1	ADRF0
ADDRESS 26	DA2SM	DA1SM	RES	RES	DA2F1	DA2F0	DA1F1	DA1F0	SCF	FRS	FRST	ADTLK	ADRF1	ADRF0	ADLF1	ADLF0	
ADDRESS 27	DFREE	RES	RES	DDMEN	RES	RES	DA2EN	DA1EN	ANAEN	HPEN	RES	AAMEN	RES	RES	ADREN	ADLEN	
ADDRESS 28	PDNI	ACEN	C3EN	C2EN	C1EN	ENCKO	XCTL1	XCTL0	ENCV3	ENBT3	ENCV2	ENBT2	ENCV1	ENBT1	LINRS	LINLS	
ADDRESS 29	RES	RES	RES	RES	RES	RES	RES	RES	RES	RES	RES	RES	RES	RES	RES	RES	
ADDRESS 30	RES	RES	RES	RES	RES	RES	RES	RES	RES	RES	RES	RES	RES	RES	RES	RES	
ADDRESS 31	RES	RES	RES	RES	RES	RES	RES	RES	RES	RES	RES	RES	RES	RES	RES	RES	

Figure 15. AD1843 Control Register Map

Figure 16 shows an annotated version of the AD1843 detailed block diagram, indicating the specific Control Register bit fields which configures the various features of the SoundComm codec.

START-UP SEQUENCE

The following paragraphs describe a typical, generic start-up sequence, for the purpose of helping hardware, systems and software driver engineers understand some of the considerations involved in bringing up a system which includes the AD1843. Note that it does not exhaustively outline all of the flexible configurations and features available in the AD1843.

- System power supplies stabilize.** Ideally, the AD1843 $\overline{\text{RESET}}$ pin should be held LO during this period. If $\overline{\text{RESET}}$ is not asserted, the AD1843 will come up in an unknown state.
- Assert the $\overline{\text{RESET}}$ signal (PLCC Pin 52, TQFP Pin 65).** Once the power supplies have stabilized, the AD1843 $\overline{\text{RESET}}$ must be asserted LO for at least 100 ns with BM (PLCC Pin 10, TQFP Pin 12) tied to the appropriate level to establish whether the codec is serial bus master or slave.
- Deassert the $\overline{\text{RESET}}$ signal and enter a wait period to allow the AD1843 internal clocks and the external crystal oscillator to stabilize.** The wait period duration will be typically 400 μs to 800 μs after $\overline{\text{RESET}}$ is deasserted, but significantly longer time may be necessary depending on XTALI and XTALO pin parasitics. If the AD1843 is serial bus master, the host CPU or DSP can poll the INIT bit (Control Register Address 0, Bit 15) to determine when the AD1843 is ready to proceed. Alternatively, the host CPU or DSP can write to Control Register 16 through 24, or 26 or 28 (using a data pattern different from the initial reset default for that Control Register), and proceed when the Control

Register readback (on the following frame) matches the data written. Writes to these Control Registers will fail until the AD1843 internal clocks are stabilized. If the system has been designed for 16 slots per frame, it is suggested that this first “polling write/readback” is to Control Register Address 26, with FRS (Bit 6) set to “1” and FRST (Bit 5) set to “1,” so that the AD1843 will support the 16 slot per frame mode immediately.

- Put the conversion resources into standby.** With the exception of the serial interface, the AD1843 is still completely powered down before this step. The PDNI bit (Control Register Address 28, Bit 15) should now be reset to “0” to initiate the process of taking the AD1843 conversion resources out of power down and into standby. This requires approximately 470 ms. An autocalibration cycle always occurs (automatically, without user programming or intervention) following the deassertion of the $\overline{\text{RESET}}$ pin or the $\overline{\text{PWRDWN}}$ pin (i.e., hardware reset or hardware power down), adding another approximately 4 ms, for a total of approximately 474 ms. Subsequent software power-down cycles, programmed using Control Register bits, do not ordinarily require additional calibration cycles. The original calibration information is retained during the power down sequence. However, the user can force an autocalibration to occur following a software power down by setting ACEN (Control Register Address 28, Bit 14) to “1.” The host CPU or DSP can poll the PDNO bit (Control Register Address 0, Bit 14) to determine when the conversion resources are out of power down. Alternatively, the host CPU or DSP can write to Control Register Address 27 (using a data pattern different from the initial reset default), and proceed when the

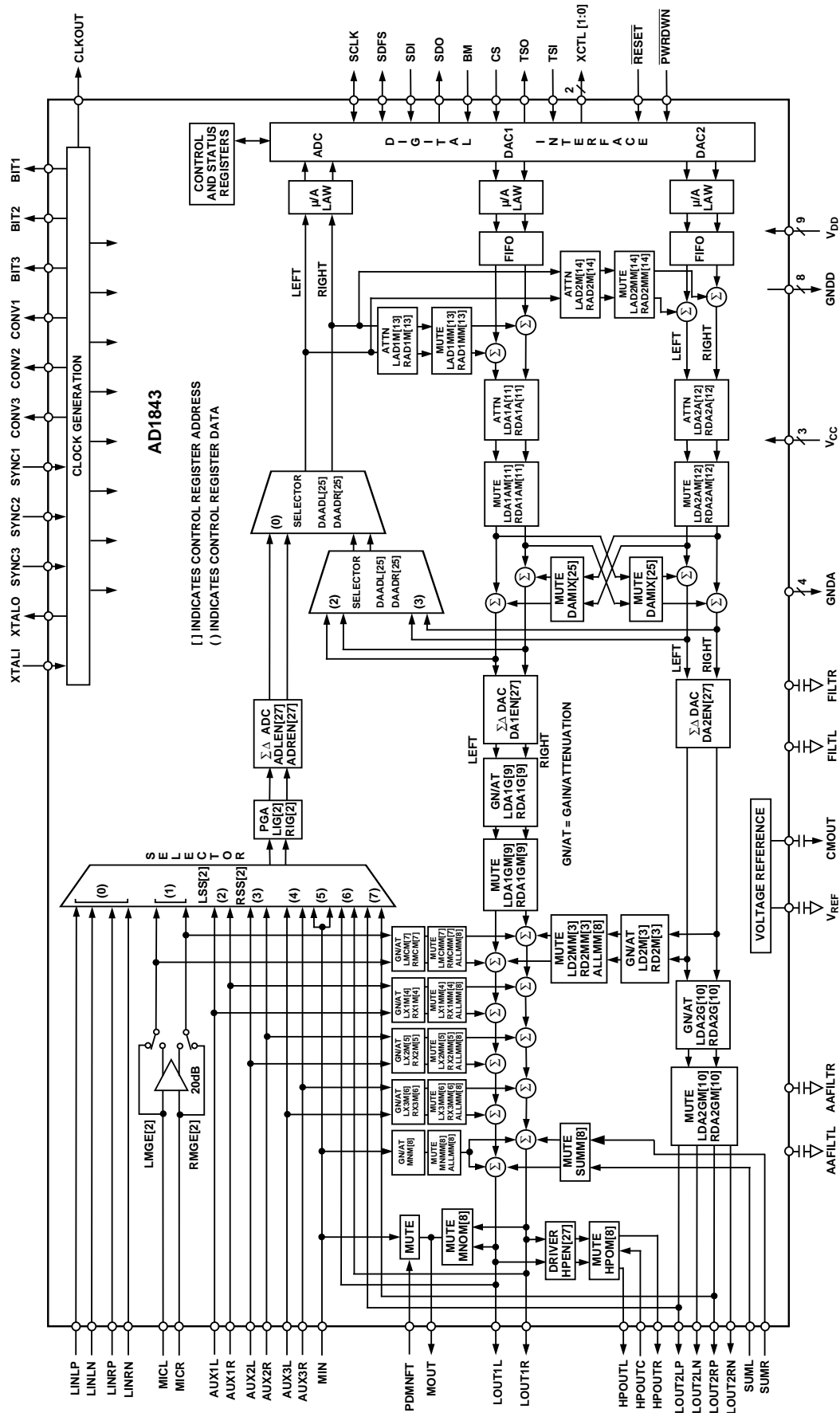

Figure 16. AD1843 Annotated Detailed Block Diagram with Control Register Address and Data Values

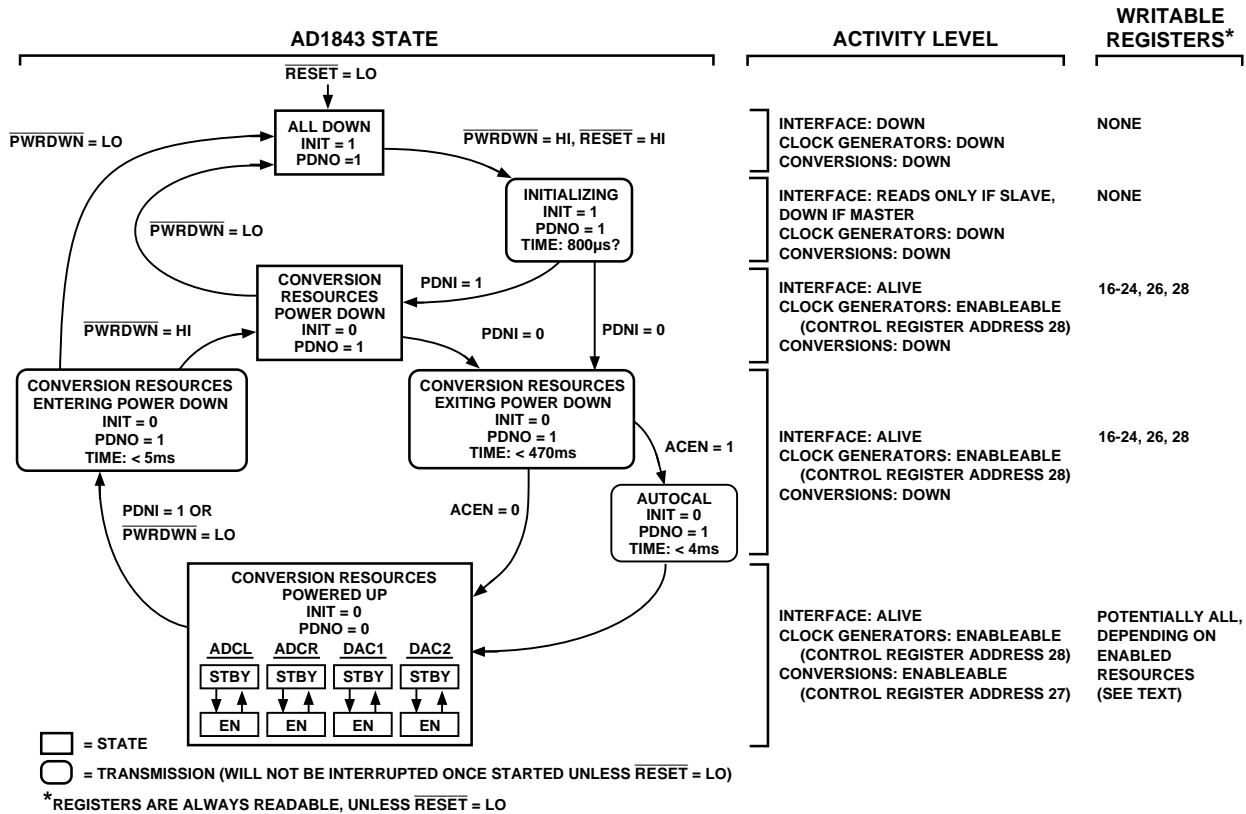

Figure 17. AD1843 Start-Up Sequence State Diagram

Control Register readback (on the following frame) matches the data written. Writes to Control Register Address 27 will fail unless the conversion resources are out of power down.

- Power up the clock generators and enable clock output pins.** When the PDNI bit (Control Register Address 28, Bit 15) is reset to “0” in Step 4 above, the C3EN, C2EN, C1EN, CONV[3:1], and BIT[3:1] bits, which are also located in Control Register Address 28, may be set to “1” to power up any clock generators which will be used, and to enable any conversion clock and bit clock outputs needed. While waiting for the conversion resources to enter standby, it is convenient to write to the clock generator Control Registers (16 through 24) to select sample rates, bit clock frequencies, external/internal sample rate lock mode, etc. This is also a convenient time to write to Control Register Address 26 (if it was not already written in Step 3) to select the serial interface configuration such as data format, SCLK frequency, etc.
- Configure conversion resources while they are in standby.** Once in standby, the conversion resources may be configured. They are forced to their defaults whenever powered down. Control Register Address 2 may be written to select between ADC sources and gain levels. Control Register Address 15 may be written to select the assignments of sample clock sources to conversion resource. Control Register Addresses 13 and 14 may be written to enable digital data flow paths which mix ADC output back into the DAC input. Control Register Address 25 may be written to select conversion resource filter mode (audio, modem or resampler), and to select digital data flow paths which may be used to achieve

digital-to-digital sample rate conversion and DAC-to-DAC digital mixing. Note that, with the exception of filter mode and DAC-to-DAC digital mixing, all of these configuration selections may also be changed while a conversion resource is out of standby and enabled.

- Enable conversion resources.** Conversion resources are taken out of standby and enabled by writes to Control Register Address 27. Control Register Address 27 contains individual enable bits for the conversion resources which are grouped as follows: DAC1 (stereo pair); DAC2 (stereo pair); ADC left channel; ADC right channel; DAC2 to DAC1 mix; and ADC input to DAC1 output mix.

If a DAC is enabled, it will begin requesting playback samples on the next TDM frame (i.e., the DA2RQ and/or the DA1RQ flags in the Status Register will be set to “1”). Conversions will not actually begin until the first rising edge of the conversion clock (assigned to the DAC) after the sixth rising edge of the frame sync (SDFS) signal. This delay allows the four word deep stereo FIFOs to be filled before conversions begin. (Six frames are required to fill a four word deep FIFO because on the first frame, the DAC playback is enabled; on the second frame, the DA2RQ and/or DA1RQ flags are set to “1”; then four more frames are required to actually fill the FIFO.)

If an ADC is enabled, sampling of the analog input will begin on the first rising edge of the conversion clock (assigned to the ADC) after the sixth rising edge of the frame sync (SDFS) signal. The data valid flags (ADRV and/or ADLV) in the Status Word will be set to a “1,” indicating a sample is being transmitted shortly thereafter. The exact TDM frame

in which the valid flag is first asserted, and continues to be asserted in future frames, depends on how the AD1843 is configured, i.e., the sample rates selected, the frame size selected, and how the shared digital resources within the AD1843 are internally allocated to process all conversion channels. Note that because of this, two ADCs which are enabled during the same frame and share the same sample rate clock, will not necessarily transmit data during the same frames thereafter, even though their analog inputs will always be sampled at the same instant in time. The two ADCs will transmit data during the same frame if ADTLK (Control Register Address 26, Bit 4) is set HI. See the description of the ADTLK bit for restrictions.

If mixing is enabled, either a mix from DAC2 to DAC1 or a mix from an ADC input to a DAC output, then the mix will begin during the same TDM frame that it is enabled.

8. Configure conversion resources while they are enabled.

Once enabled, DAC output gain/attenuation levels may be changed using Control Register Addresses 3 through 10. These registers are forced to their default of full attenuation whenever the resource they control is either in standby or completely powered down. Note that while a conversion resource is enabled, all configuration selections related to it may be changed except those outlined in Step 6.

The AD1843 Start-Up Sequence state diagram is shown in Figure 17.

APPLICATIONS CIRCUITS

The AD1843 SoundComm Codec has been designed to require a minimum of external circuitry. The recommended circuits are shown in Figures 18 through 34. Analog Devices estimates that the total cost of all the components shown in these Figures (including the crystal but not including the DAA) to be less than \$6 in 10,000 piece quantities.

Industry-standard compact disc “line-levels” are 2 V rms centered around analog ground. (For other audio equipment, “line level” is much more loosely defined.) The AD1843 SoundComm Codec is a +5 V analog supply powered device. Nominal line level voltage swings for the AD1843 are defined to be 1 V rms (ADRFLT and ADLFLT = 0) for a sine wave ADC input and 0.707 V rms for a sine wave DAC output (DA2FLT = 0). Thus, 2 V rms input analog signals must be attenuated and either centered around the reference voltage intermediate between 0 V and +5 V or ac-coupled. The CMOUT pin will be at this intermediate voltage, nominally 2.25 V. It has limited drive but can be used as a voltage datum to an op amp input. CMOUT loading should be minimized to limit any audible clicks and pops. Note that dc-coupled inputs are not recommended, as they provide no performance benefits with the AD1843 architecture. Furthermore, dc offsets on inputs create the potential for clicks when changing the input mix gain/attenuation/mute.

The $\overline{\text{RESET}}$ pin must be asserted at or shortly after power up in order to initialize the AD1843 Control Registers to their default states. If the AD1843 will not be used immediately, and if it is desired to utilize the mono input to mono output feedthrough feature, it is essential that the mono output is ac-coupled to prevent audible pops and clicks. It is recommended that all outputs are ac coupled, as standing current in output loads or in the voltage reference will contribute to audible pops and clicks.

A circuit for 2 V rms line-level inputs is shown in Figure 18. Note that this is a divide-by-two resistive divider, and that the line input is being used in a single-ended configuration. The 1 μF ac-coupling capacitor may be of any type (tantalum is a popular choice).

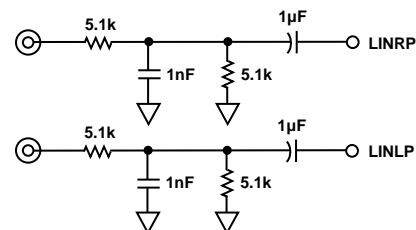

Figure 18. AD1843 2 V rms Single-Ended Line-Level Input Circuit

If line-level inputs are already at the 1 V rms levels expected by the AD1843, the circuit shown in Figure 19 below should be used. Note that when single-ended line inputs are desired, only the LINRP and LINLP pins are used. DO NOT use the LINRN or LINLN pins if the line input is single-ended.

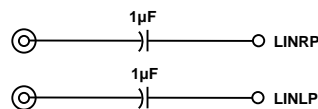

Figure 19. AD1843 1 V rms Single-Ended Line-Level Input Circuit

The three auxiliary inputs, the SUM inputs, and the mono input of the AD1843 present an input impedance which is lower than the stereo line input. The circuit shown in Figure 20 should be used with 2 V rms swings on these inputs. With 1 V rms swings, the circuit in Figure 19 above should be used.

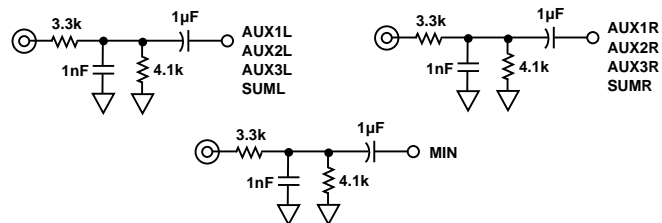

Figure 20. AD1843 2 V rms Aux, SUM, and Mono Input Circuits

For optimal performance, the AD1843 includes provision for a differential configuration of the LIN inputs. Figure 21 illustrates a simple single-ended to differential converter. For the best noise immunity, the circuitry to the left of the dotted line should be located as close to the driving signal source as possible. **The 0.9K resistor and the 1000 pF capacitor are mandatory when using the LINRN and/or the LINLN inputs.** Furthermore, the 0.9K resistor and the 1000 pF NPO capacitor should be located as close to the AD1843 as possible. If the output range of the source does not match that of the AD1843 input, the op amp gain setting resistor values should be scaled to match the source voltage range to the AD1843 input voltage range.

Inexpensive feedback capacitors can be added (as shown in the Figure 21 with dotted lines) for additional noise filtering (6 dB per octave). Without the additional filter capacitor, there is a single antialiasing pole at approximately 160 kHz. There is

AD1843

“room” in the frequency domain for a second pole, especially in modem applications, where the signal bandwidth is 4.2 kHz. A suggested capacitor value is 120 pF when using the 10K op amp feedback resistor as shown, for a -3 dB point of approximately 133 kHz. Note that the combined effect of both filters causes a gain error of approximately 0.1% at 4.2 kHz.

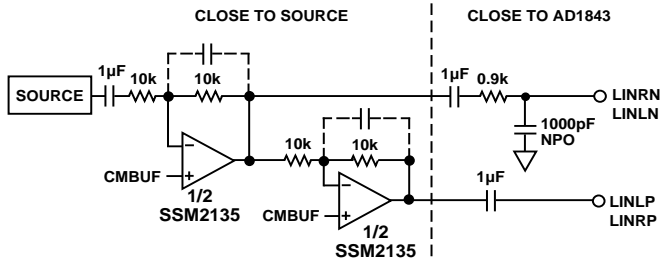

Figure 21. Single-Ended to Differential Converter

The AD1843 Codec contains an optional +20 dB gain block to accommodate condenser microphones. Particular system requirements will depend upon the characteristics of the intended microphone. Figure 22 illustrates one example of how an electret condenser mic requiring phantom power could be connected to the AD1843. CMOUT is shown buffered by an op amp; the current drawn from CMOUT should be as minimal as possible. Note that if a battery-powered microphone is used, the buffer and R2s are not needed. The values of R1, R2, and C should be chosen in light of the mic characteristics and intended gain. Typical values for these might be R1 = 20 kΩ, R2 = 2 kΩ, and C = 220 pF. Figure 22 shows a voltage follower buffer on the CMOUT signal. The output of this buffer, CMBUF, can be used in any circuit which needs the common-mode bias point from the AD1843’s on-chip voltage reference. The AD820 is a JFET input op amp whose very high impedance inputs present essentially no load on the CMOUT output from the AD1843.

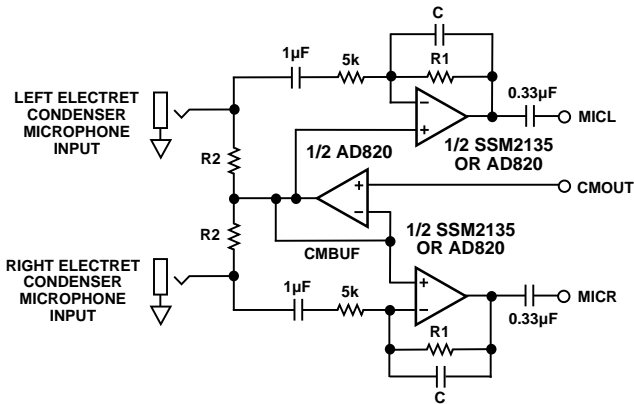

Figure 22. AD1843 “Phantom-Powered” Microphone Input Circuit

Connect unused analog inputs to CMBUF or leave them unconnected; do not connect unused analog inputs to either analog power or ground!

Figure 23 shows ac-coupled line outputs. The resistors are used to center the output signals around analog ground. If dc-coupling is desired, CMOUT could be used with op amps as mentioned above, if desired.

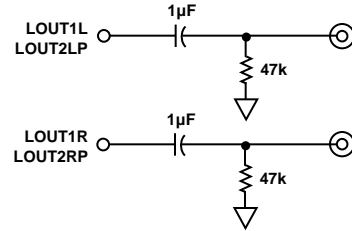

Figure 23. AD1843 (Single-Ended) Line Output Connections

For optimal performance, the AD1843 DAC2 output has provision for a differential configuration. A simple differential-to-single-ended conversion circuit is shown in Figure 24. The noise rejection of this circuit is limited by the match of the R_i and R_f resistors. The resistors should be 1% tolerance components. The equation that determines the output voltage is as follows:

$$V_o = (R_f/R_i)(V_+) - (R_f/R_i)(V_-)$$

For maximum noise immunity, this circuit should be located in close proximity to where V_o is processed. Another differential receiver option is the SSM2141, which provides better matching than a discrete implementation.

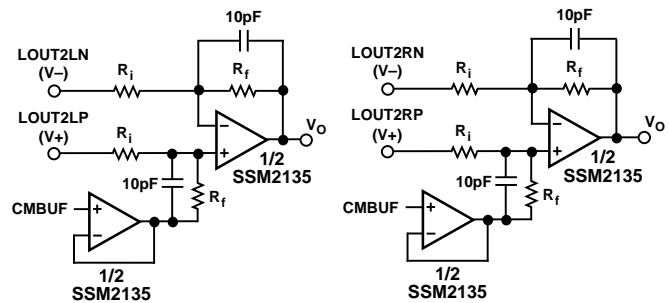

Figure 24. AD1843 Differential-to-Single-Ended Converter Line Output Connections

A circuit for headphone drive is illustrated in Figure 25. The AD1843 headphone output is designed to drive loads of 32 ohms or smaller (i.e., higher impedance). If larger loads are used (e.g., 16 ohms or 8 ohms), the analog output will be distorted for large output signals because of current limiting. “Walkman”-type headphone impedances are generally around 32 ohms. Telephone handset impedances are typically 150 ohms.

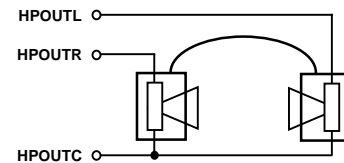

Figure 25. AD1843 Headphone Drive Connections

Figure 26 shows an example circuit for the mono output (MOUT) from the AD1843. The OP279 is a single +5 V supply op amp which can drive a small 8 ohm or 16 ohm speaker to modest levels.

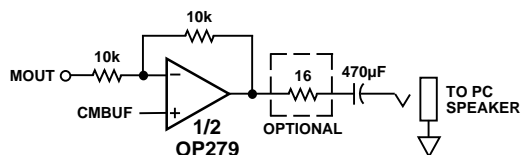

Figure 26. AD1843 Mono Output Circuit

Figure 27 illustrates reference bypassing. V_{REF} should only be connected to its bypass capacitors. The $10\ \mu\text{F}$ capacitor should be tantalum, and the $0.1\ \mu\text{F}$ capacitor should be ceramic. Figure 27 shows an optional voltage follower buffer on the CMOUT signal. The output of this buffer, CMBUF, can be used in any circuit which needs the common-mode bias point from the AD1843's on-chip voltage reference. The AD820 is a JFET input op amp whose very high impedance inputs present essentially no load on the CMOUT output from the AD1843.

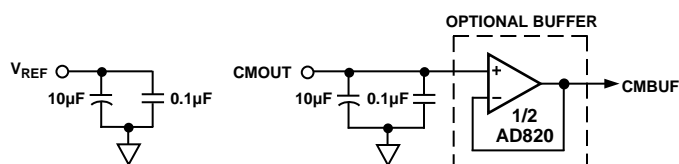

Figure 27. AD1843 Voltage Reference Bypassing

Figure 28 illustrates the signal-path filtering capacitors, FILTL and FILTR, connections to analog ground. The $1.0\ \mu\text{F}$ capacitors required by the AD1843 can be of any type.

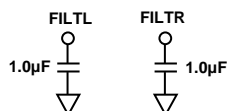

Figure 28. AD1843 External Filter Capacitor Connections

Figure 29 illustrates the antialias filtering capacitors, AAFILTL and AAFILTR, connections to analog ground. The $1000\ \text{pF}$ capacitors must be NPO types.

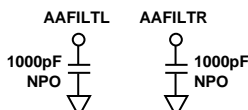

Figure 29. AD1843 Antialias Filter Capacitor Connections

The $24.576\ \text{MHz}$ crystal shown in the crystal connection circuitry of Figure 30 should be fundamental-mode and parallel-tuned. Note that using the exact data sheet frequency is not

required and that external clock sources can be used in place of the AD1843's internal oscillator. If using an external clock source, apply it to the crystal input pin (XTALI) while leaving the crystal output pin (XTALO) unconnected. Attention

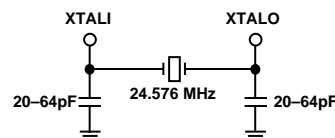

Figure 30. AD1843 Crystal Connections

should be paid to providing a low-jitter external input clock. Ideally, there should be no greater than $5\ \text{ns}$ rms of random (white) phase jitter to ensure that it does not significantly degrade the SNR of the AD1843.

Figure 31 and Figure 32 show example circuits for a Data Access Arrangement (DAA). These circuits are shown as examples only; DAA circuits are subject to regulatory approval since they connect directly to the Public Switched Telephone Network (PSTN).

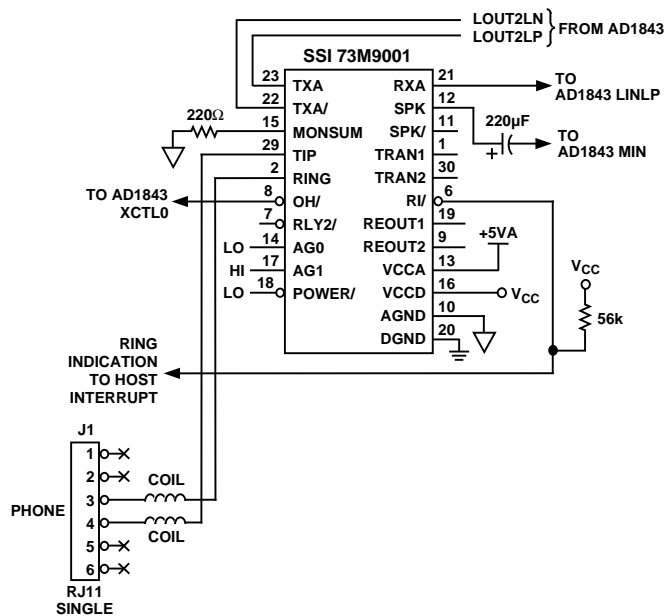
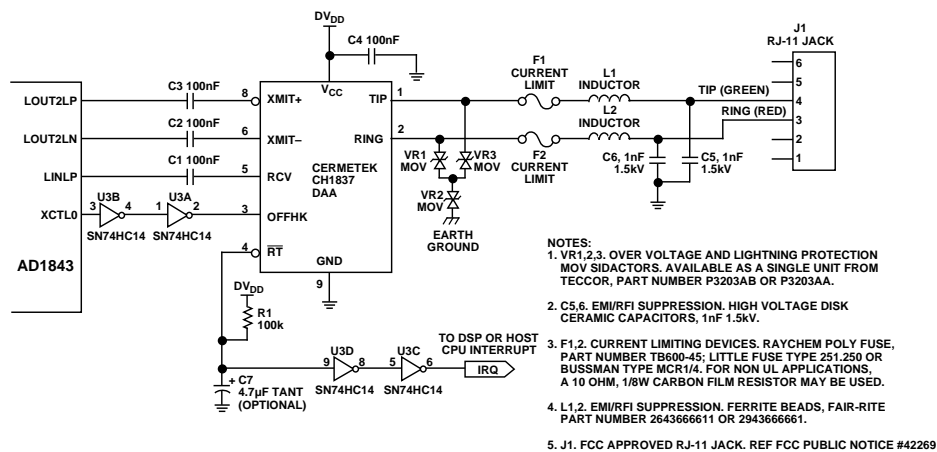

Figure 31. Silicon Systems DAA Example Circuit



- NOTES:
- VR1,2,3. OVER VOLTAGE AND LIGHTNING PROTECTION MOV SIDACTORS. AVAILABLE AS A SINGLE UNIT FROM TECCOR, PART NUMBER P3203AB OR P3203AA.
 - C5,6. EMI/RFI SUPPRESSION. HIGH VOLTAGE DISK CERAMIC CAPACITORS, $1\ \text{nF}$ $1.5\ \text{kV}$.
 - F1,2. CURRENT LIMITING DEVICES. RAYCHEM POLY FUSE, PART NUMBER TB600-45; LITTLE FUSE TYPE 251.250 OR BUSSMAN TYPE MCR1/4. FOR NON UL APPLICATIONS, A $10\ \Omega$, $1/8\ \text{W}$ CARBON FILM RESISTOR MAY BE USED.
 - L1,2. EMI/RFI SUPPRESSION. FERRITE BEADS, FAIR-RITE PART NUMBER 2643666611 OR 2943666611.
 - J1. FCC APPROVED RJ-11 JACK. REF FCC PUBLIC NOTICE #42269

Figure 32. Cermetek DAA Example Circuit

AD1843

Good, standard engineering practices should be applied for power-supply decoupling. Decoupling capacitors should be placed as close as possible to package pins. If a separate analog power supply is not available, we recommend the circuit shown in Figure 33 for using a single +5 V supply. This circuitry should be as close to the supply pins as is practical.

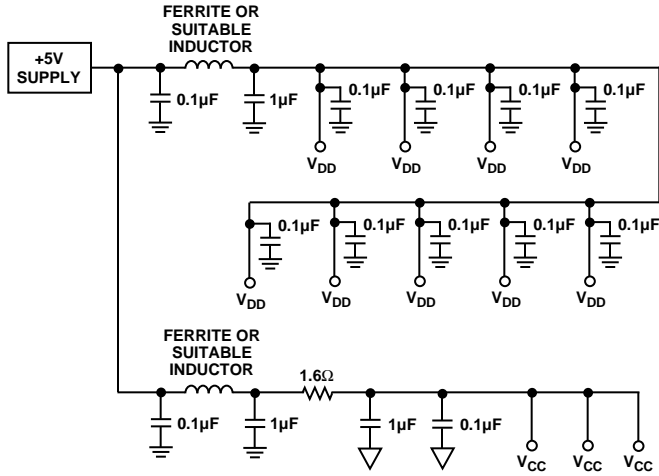

Figure 33. AD1843 Recommended Power Supply Bypassing

Figure 34 illustrates an optional circuit for generating the +5 V analog supply for the AD1843. The +12 V rail available on the ISA bus can be regulated down to +5 V using an ordinary 7805 three-terminal regulator and the bypassing and decoupling capacitors shown. The digital supply should still be decoupled and bypassed as shown above in Figure 33.

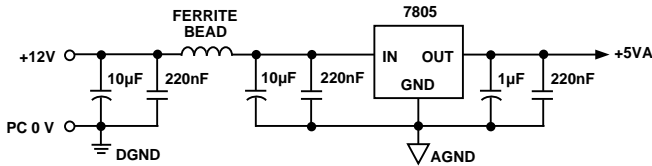

Figure 34. AD1843 Optional Analog Supply Regulation

Analog Devices recommends a split ground plane as shown in Figure 35a (PQFP) and Figure 35b (TQFP). The analog plane and the digital plane are connected directly under the AD1843. Splitting the ground plane directly under the SoundComm Codec is optimal because analog pins will be located above the analog ground plane and digital pins will be located directly above the digital ground plane for the best isolation. The digital ground and analog ground should be tied together in the vicinity of the AD1843. Other schemes may also yield satisfactory results. If the split ground plane recommended here is not possible, the AD1843 should be entirely over the analog ground plane.

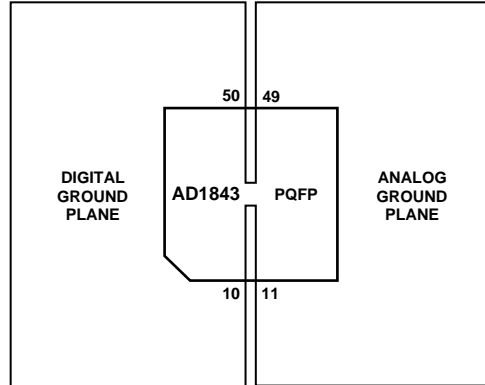

Figure 35a. AD1843 Recommended PQFP Ground Plane

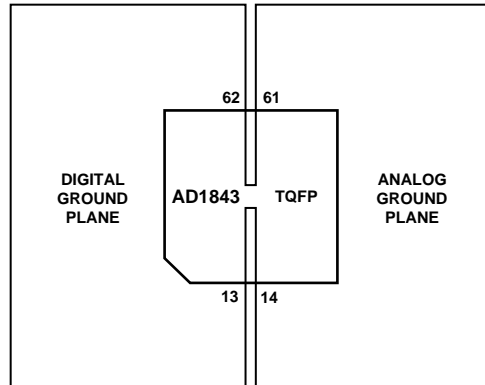
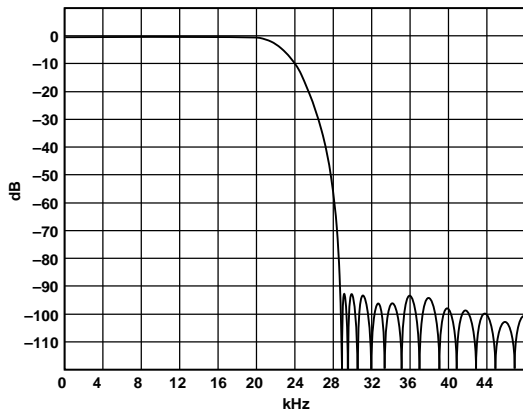
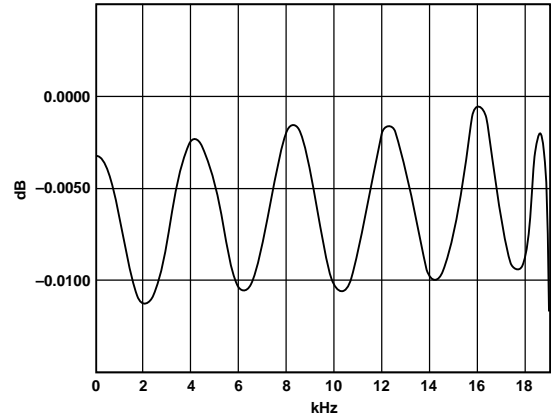

Figure 35b. AD1843 Recommended TQFP Ground Plane

Frequency Response Plots—AD1843



a. ADC Audio Full



c. ADC Audio Passband

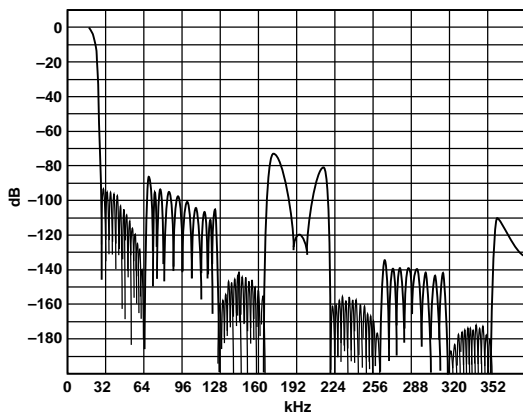

b. DAC Audio 0–384 kHz

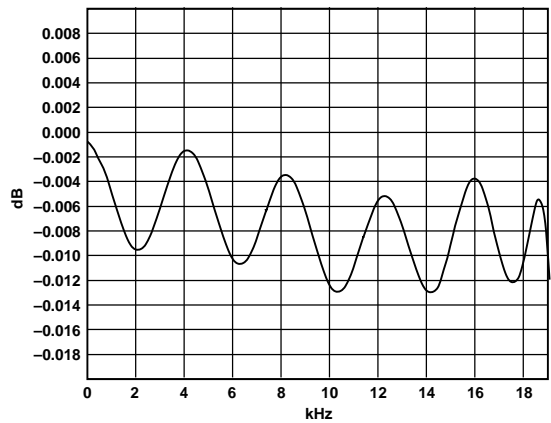

d. DAC Audio Passband

Figure 36. AD1843 Audio Mode Frequency Response Plots (Full-Scale Line-Level Inputs, 0 dB Gain) Based on 48 kHz sample rate; other sample rates will show slightly different behavior. See the "Specifications" section for performance limits. The DAC plots do not reflect the additional beneficial roll-off of the AD1843 analog filters. Out-of-band images will be attenuated by an additional 31.4 dB at 100 kHz.

AD1843

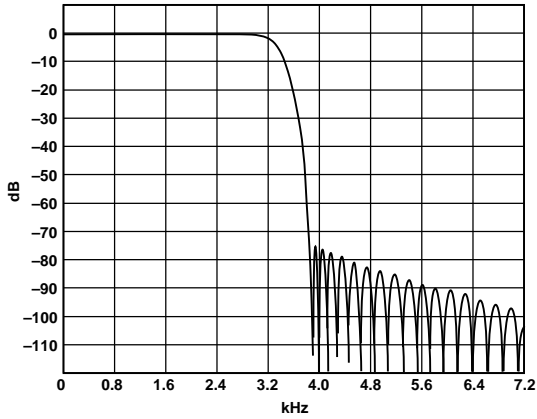

a. ADC Modem Full

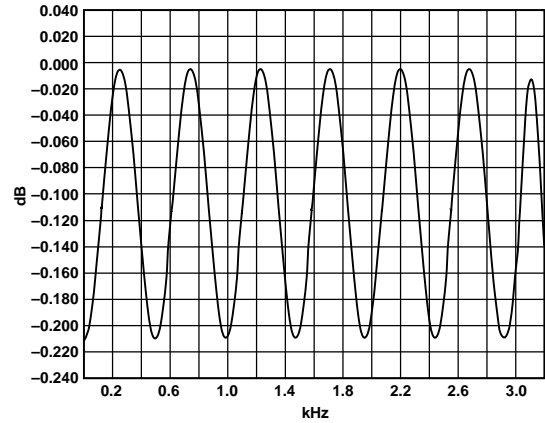

c. ADC Modem Passband

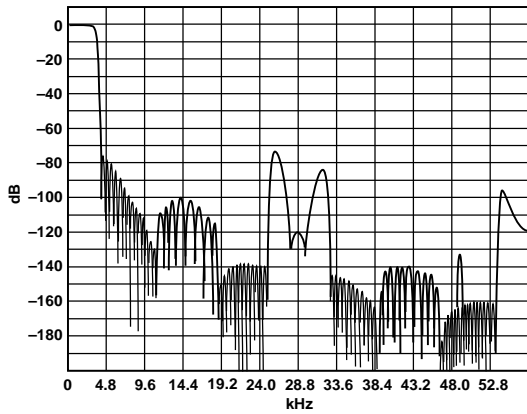

b. DAC Modem 0-57.6 kHz

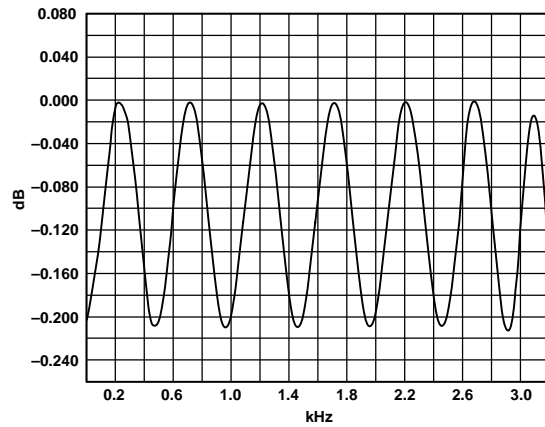

d. DAC Modem Passband

Figure 37. AD1843 Modem Mode Frequency Response Plots (Full-Scale Line-Level Inputs, 0 dB Gain) Based on 7.2 kHz sample rate; other sample rates will show slightly different behavior. See the "Specifications" section for performance limits. The DAC plots do not reflect the additional beneficial roll-off of the AD1843 analog filters. Out-of-band images will be attenuated by an additional 31.4 dB at 100 kHz.

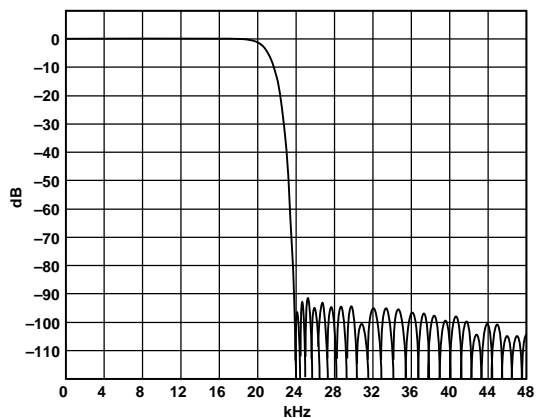

a. ADC Resampler Full

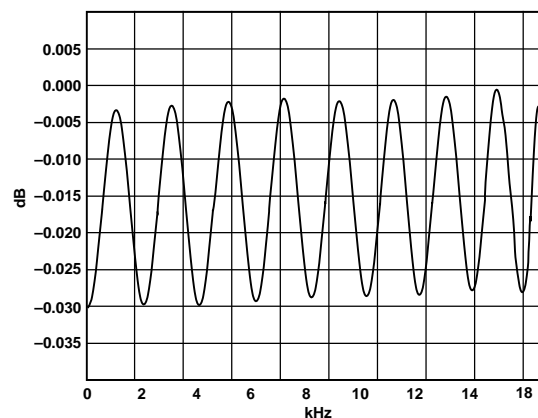

c. ADC Resampler Passband

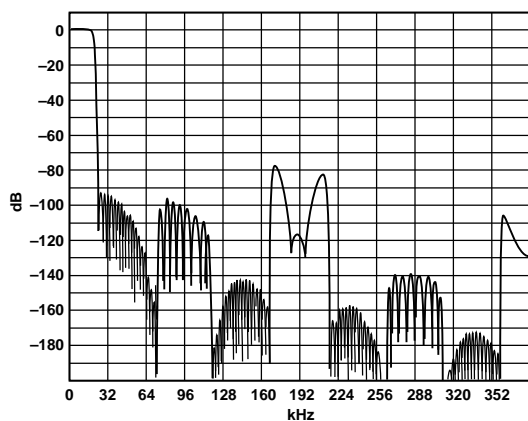

b. DAC Resampler 0-384 kHz

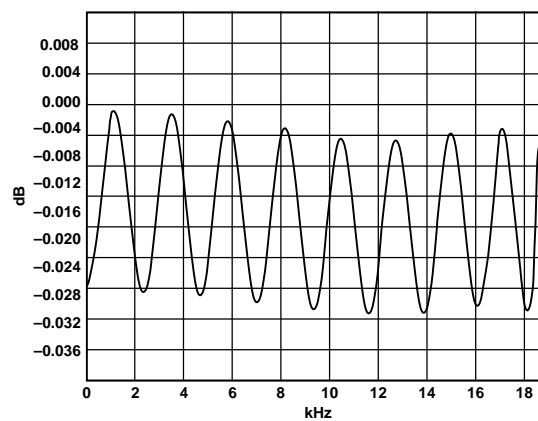

d. DAC Resampler Passband

Figure 38. AD1843 Resampler Mode Frequency Response Plots (Full-Scale Line-Level Inputs, 0 dB Gain) Based on 48 kHz sample rate; other sample rates will show slightly different behavior. See the "Specifications" section for performance limits. The DAC plots do not reflect the additional beneficial roll-off of the AD1843 analog filters. Out-of-band images will be attenuated by an additional 31.4 dB at 100 kHz.

TABLE OF CONTENTS

FEATURES	1
GENERAL PRODUCT DESCRIPTION	1
SPECIFICATIONS	2
ORDERING INFORMATION	6
PIN DESCRIPTION	7
PIN CONFIGURATIONS	7, 8
DETAILED FUNCTIONAL BLOCK DIAGRAM	12
DETAILED PRODUCT DESCRIPTION	13
FUNCTIONAL DESCRIPTION	13
SERIAL INTERFACE	19
SERIAL INTERFACE INPUT	22
SERIAL INTERFACE OUTPUT	24
CONTROL REGISTERS	25
BIT AND REGISTER MAPS	51
START-UP SEQUENCE	52
APPLICATIONS CIRCUITS	55
FREQUENCY RESPONSE PLOTS	59

OUTLINE DIMENSIONS

Dimensions shown in inches and (mm)

