



# Intel® IXP1200 Network Processor

## Datasheet

### Product Features

The Intel® IXP1200 Network Processor delivers high-performance processing power and flexibility to a wide variety of LAN and telecommunications products. Distinguishing features of the IXP1200 are the performance of ASIC hardware along with programmability of a microprocessor.

- **Applications**
  - Multi-layer LAN Switches
  - Multi-protocol Telecommunications Products
  - Broadband Cable Products
  - Remote Access Devices
  - Intelligent PCI adapters
- **Integrated StrongARM Core**
  - High-performance, low-power, 32-bit Embedded RISC processor
  - 16 Kbyte instruction cache
  - 8 Kbyte data cache
  - 512 byte mini-cache for data that is used once and then discarded
  - Write buffer
  - Memory management unit
  - Access to IXP1200 FBI Unit, PCI Unit and SDRAM Unit via the ARM\* AMBA Bus
- **Six Integrated Programmable Microengines**
  - Operating frequency of up to 232 MHz
  - Multi-thread support of four threads per microengine
  - Single-cycle ALU and shift operations
  - Zero context swap overhead
  - Large Register Set: 128 General-Purpose and 128 Transfer Registers
  - 2 K x 32-bit Instruction Control Store
  - Access to the IXP1200 FBI Unit, PCI DMA channels, SRAM, and SDRAM
- **High Bandwidth I/O Bus (IX Bus)**
  - 64-bit, up to 104 MHz operation
  - 6.6 Gbps peak bandwidth
  - 64-bit or dual 32-bit bus options
- **Integrated 32-bit, 66 MHz PCI Interface**
  - Supports PCI 2.2 as a Bus Master
  - 264 Mbytes/sec peak burst mode operation
  - I<sub>2</sub>O\* support for StrongARM Core
  - Dual DMA channels
- **Industry Standard 64-bit SDRAM Interface**
  - Peak bandwidth of up to 928 Mbytes/sec
  - Address up to 256 Mbytes of SDRAM
  - Memory bandwidth improvement through bank switching
  - Read-modify-write support
  - Byte aligner/merger
- **Industry Standard 32-bit SRAM Interface**
  - Peak bandwidth of up to 464 Mbytes/sec
  - Address up to 8 Mbytes of SRAM
  - Up to 8 Mbytes FlashROM for booting StrongARM Core
  - Supports atomic push/pop operations
  - Supports atomic bit set and bit clear operations
  - Memory bandwidth improvement by reduced read/write turnaround bus cycles
- **Other Integrated Features**
  - Hardware Hash Unit for generation of 48- or 64-bit adaptive polynomial hash keys
  - Serial UART port
  - Real Time Clock
  - Four general-purpose I/O pins
  - Four 24-bit timers with CPU watchdog support
  - Limited JTAG Support
  - 4 Kbyte Scratchpad Memory
- **432-pin, HL-BGA package**
- **2 V CMOS device**
  - 3.3 V tolerant I/O
- **IXP1200 Developer Workbench**
  - Integrated Development Environment
  - Text Editor
  - Microcode Assembler
  - StrongARM and Microcode Linker
  - Cycle accurate Transactor Simulator

**Notice:** This document contains preliminary information on new products in production. The specifications are subject to change without notice. Verify with your local Intel sales office that you have the latest datasheet before finalizing a design.

## Revision History

---

Date	Revision	Description
8/30/99	001	Initial Release
1/1/00	002	Beta 3 Release
3/3/00	003	Beta 4 Release. Contains B0 step changes and TME input.
5/26/00	004	Version 1.0 release. Updates for 200 MHz version.
9/27/00	005	Version 1.1 release.
12/13/00	006	C0 stepping updates.
02/21/01	007	Updated power and derating tables in Section 7.
05/11/01	008	Updated power and derating tables and made miscellaneous corrections.
08/10/01	009	Updates for the V2.0 SDK release. Changes to the SRAM Bus and SDRAM Bus signal timing parameters.
12/10/01	010	Updates for the V2.01 SDK release.

Information in this document is provided in connection with Intel® products. No license, express or implied, by estoppel or otherwise, to any intellectual property rights is granted by this document. Except as provided in Intel's Terms and Conditions of Sale for such products, Intel assumes no liability whatsoever, and Intel disclaims any express or implied warranty, relating to sale and/or use of Intel products including liability or warranties relating to fitness for a particular purpose, merchantability, or infringement of any patent, copyright or other intellectual property right. Intel products are not intended for use in medical, life saving, or life sustaining applications.

Intel may make changes to specifications and product descriptions at any time, without notice.

Designers must not rely on the absence or characteristics of any features or instructions marked "reserved" or "undefined." Intel reserves these for future definition and shall have no responsibility whatsoever for conflicts or incompatibilities arising from future changes to them.

The IXP1200 Network Processor may contain design defects or errors known as errata which may cause the product to deviate from published specifications. Current characterized errata are available on request.

Contact your local Intel sales office or your distributor to obtain the latest specifications and before placing your product order.

Copies of documents which have an ordering number and are referenced in this document, or other Intel literature may be obtained by calling 1-800-548-4725 or by visiting Intel's website at <http://www.intel.com>.

Copyright © Intel Corporation, 2001

Intel is a registered trademark of Intel Corporation or its subsidiaries in the United States and other countries

\*Other names and brands may be claimed as the property of others.

# Contents

---

1.0	Product Description .....	9
2.0	Introduction.....	11
3.0	Related Documents.....	11
4.0	Conventions .....	11
5.0	Functional Units.....	12
5.1	StrongARM* Core.....	12
5.2	Microengines .....	12
5.3	FBI Unit and the IX Bus.....	12
5.3.1	IX Bus Access Behavior .....	13
5.3.1.1	Reset and Idle Bus Considerations .....	15
5.4	SDRAM and SRAM Units.....	15
5.4.1	SDRAM Unit .....	16
5.4.2	SDRAM Bus Access Behavior .....	17
5.4.3	SDRAM Configurations .....	17
5.4.4	SRAM Unit.....	18
5.4.4.1	SRAM Types Supported.....	19
5.4.4.2	SRAM Configurations.....	20
5.4.4.3	BootROM Configurations .....	20
5.4.4.4	SRAM Bus Access Behavior .....	20
5.5	PCI Unit.....	21
5.5.1	PCI Arbitration and Central Function Support .....	22
5.6	Device Reset.....	22
5.6.1	Hardware Initiated Reset.....	24
5.6.2	Software Initiated Reset .....	24
5.6.3	PCI Initiated Reset .....	24
5.6.4	Watchdog Timer Initiated Reset .....	24
6.0	Signal Description .....	25
6.1	Pinout Diagram.....	25
6.2	Pin Type Legend .....	26
6.3	Pin Description, Grouped by Function.....	27
6.3.1	Processor Support Pins.....	27
6.3.2	SRAM Interface Pins .....	28
6.3.3	SDRAM Interface Pins .....	30
6.3.4	IX Bus Interface Pins.....	32
6.3.5	General Purpose I/Os.....	36
6.3.6	Serial Port (UART) Pins .....	36
6.3.7	PCI Interface Pins .....	37
6.3.8	Power Supply Pins .....	40
6.3.9	IEEE 1149.1 Interface Pins .....	41
6.3.10	Miscellaneous Test Pins.....	41
6.3.11	Pin Usage Summary .....	42
6.4	Pin/Signal List.....	43
6.5	Signals Listed in Alphabetical Order .....	47

6.6	IX Bus Pins Function Listed by Operating Mode.....	52
6.7	IX Bus Decode Table Listed by Operating Mode Type .....	62
6.8	Pin State During Reset.....	64
6.9	Pullup/Pulldown and Unused Pin Guidelines .....	66
7.0	Electrical Specifications .....	67
7.1	Absolute Maximum Ratings .....	67
7.2	DC Specifications.....	70
7.2.1	Type 1 Driver DC Specifications .....	70
7.2.2	Type 2 Driver DC Specifications .....	71
7.2.3	Overshoot/Undershoot Specifications .....	71
7.3	AC Specifications .....	72
7.3.1	Clock Timing Specifications .....	72
7.3.2	PXTAL Clock Input.....	72
7.3.3	PXTAL Clock Oscillator Specifications.....	73
7.3.4	PCI .....	73
7.3.4.1	PCI Electrical Specification Conformance.....	73
7.3.4.2	PCI Clock Signal AC Parameter Measurements.....	73
7.3.4.3	PCI Bus Signals Timing.....	75
7.3.5	Reset.....	76
7.3.5.1	Reset Timings Specification .....	76
7.3.6	IEEE 1149.1 .....	77
7.3.6.1	IEEE 1149.1 Timing Specifications .....	78
7.3.7	IX Bus.....	80
7.3.7.1	FCLK Signal AC Parameter Measurements.....	80
7.3.7.2	IX Bus Signals Timing .....	81
7.3.7.3	IX Bus Protocol.....	83
7.3.7.4	RDYBus.....	117
7.3.7.5	TK_IN/TK_OUT .....	120
7.3.8	SRAM Interface .....	120
7.3.8.1	SRAM SCLK Signal AC Parameter Measurements .....	120
7.3.8.2	SRAM Bus Signal Timing .....	122
7.3.8.3	SRAM Bus - SRAM Signal Protocol and Timing .....	124
7.3.8.4	SRAM Bus - BootROM and SlowPort Timings.....	128
7.3.8.5	SRAM Bus - BootRom Signal Protocol and Timing.....	128
7.3.8.6	SRAM Bus - Slow-Port Device Signal Protocol and Timing....	131
7.3.9	SDRAM Interface .....	135
7.3.9.1	SDCLK AC Parameter Measurements.....	135
7.3.9.2	SDRAM Bus Signal Timing .....	136
7.3.9.3	SDRAM Signal Protocol .....	137
7.4	Asynchronous Signal Timing Descriptions.....	141
8.0	Mechanical Specifications.....	142
8.1	Package Dimensions .....	142
8.2	IXP1200 Package Dimensions (mm) .....	144

## Figures

1	Block Diagram.....	9
2	IXP1200 System Block Diagram .....	10
3	SDRAM Unit Block Diagram .....	16
4	SRAM Unit Block Diagram .....	18

5	Reset Logic .....	23
6	Pinout Diagram.....	25
7	64-Bit Bidirectional IX Bus, 1-2 MAC Mode.....	52
8	64-Bit Bidirectional IX Bus, 1-2 MAC Mode, FastPort Device .....	53
9	64-Bit Bidirectional IX Bus, 3+ MAC Mode.....	55
10	32-Bit Unidirectional IX Bus, 1-2 MAC Mode .....	58
11	32-bit Unidirectional IX Bus, 3+ MAC Mode (3-4 MACs Supported).....	60
12	Typical IXP1200 Heatsink Application.....	69
13	PXTAL Clock Input .....	72
14	PCI Clock Signal AC Parameter Measurements.....	73
15	PCI Bus Signals .....	74
16	RESET_IN# Timing Diagram .....	76
17	IEEE 1149.1/Boundary-Scan General Timing.....	78
18	IEEE 1149.1/Boundary-Scan Tri-State Timing.....	79
19	FCLK Signal AC Parameter Measurements.....	80
20	IX Bus Signals Timing .....	81
21	64-Bit Bidirectional IX Bus Timing, 1-2 MAC Mode, Consecutive Receive and Transmit, No EOP .....	83
22	64-Bit Bidirectional IX Bus Timing - Consecutive Receive and Transmit, No EOP .....	84
23	64-Bit Bidirectional IX Bus Timing - Consecutive Receive and Transmit, EOP on 8th Data Return with Status.....	85
24	64-Bit Bidirectional IX Bus Timing - Consecutive Receive and Transmit, EOP on 7th Data Return with Status.....	86
25	64-Bit Bidirectional IX Bus Timing - Consecutive Receive and Transmit, EOP on 6th Data Return with Status.....	87
26	64-Bit Bidirectional IX Bus Timing - Consecutive Receive and Transmit, EOP on 5th Data Return with Status.....	88
27	64-Bit Bidirectional IX Bus Timing - Consecutive Receive and Transmit, EOP on 4th Data Return with Status.....	89
28	64-Bit Bidirectional IX Bus Timing - Consecutive Receive and Transmit, EOP on 1st through 3rd Data Return with Status (3rd Data Return Shown).....	90
29	64-Bit Bidirectional IX Bus Timing - Consecutive Receives, EOP on 1st Data Return, No Status.....	91
30	64-Bit Bidirectional IX Bus Timing - Consecutive Receives, No EOP.....	92
31	64-Bit Bidirectional IX Bus Timing - Consecutive Receives, EOP on 8th Data Return with Status .....	93
32	64-Bit Bidirectional IX Bus Timing - Consecutive Receives, EOP on 7th Data Return with Status .....	94
33	64-Bit Bidirectional IX Bus Timing - Consecutive Receives, EOP on 6th Data Return with Status.....	95
34	64-Bit Bidirectional IX Bus Timing - Consecutive Receives, EOP, Two Element Transfer with Status .....	96
35	64-Bit Bidirectional IX Bus Timing - Consecutive Receives, Fetch-9, No EOP... ..	97
36	64-Bit Bidirectional IX Bus Timing - Consecutive Transmits, EOP.....	98
37	64-Bit Bidirectional IX Bus Timing - Consecutive Transmits with Prepend, EOP.....	99
38	32-Bit Unidirectional IX Bus Timing - Consecutive Receives, No EOP.....	100
39	32-Bit Unidirectional IX Bus Timing - Consecutive Receives, EOP on 16th Data Return with Status .....	101
40	32-Bit Unidirectional IX Bus Timing - Consecutive Receives, EOP on 15th Data Return with Status .....	102

41	32-Bit Unidirectional IX Bus Timing - Consecutive Receives, EOP on 14th Data Return with Status .....	103
42	32-Bit Unidirectional IX Bus Timing - Consecutive Receives, EOP on 1st Through 13th Data Return with Status (13th Data Return Shown) .....	104
43	32-Bit Unidirectional IX Bus Timing - Consecutive Receives, EOP, 64-Bit Status .....	105
44	32-Bit Unidirectional IX Bus Timing - Consecutive Receives, Two Element Transfers with 32-Bit Status .....	106
45	32-Bit Unidirectional IX Bus Timing - Consecutive Transmits, EOP .....	107
46	32-Bit Unidirectional IX Bus Timing - Consecutive Transmits with Prepend, EOP .....	108
47	64-Bit Bidirectional IX Bus Timing - Consecutive FastPort Receives, Same Port, EOP, No Status, FP_READY_WAIT=0 .....	109
48	64-Bit Bidirectional IX Bus Timing - Consecutive FastPort Receives, Same Port, EOP, No Status, FP_READY_WAIT=5 .....	110
49	64-Bit Bidirectional IX Bus Timing - Consecutive FastPort Receives, Same Port, EOP, with Status, FP_READY_WAIT=0 .....	111
50	64-Bit Bidirectional IX Bus Timing - Consecutive FastPort Receives, Same Port, EOP, No Status, FP_READY_WAIT=5 .....	112
51	64-Bit Bidirectional IX Bus Timing - Consecutive FastPort Receives, Same Port, EOP, No Status, FP_READY_WAIT=0, Cancelled Request .....	113
52	64-Bit Bidirectional IX Bus Timing - Consecutive FastPort Receives, Same Port, No EOP, FP_READY_WAIT=Don't Care .....	114
53	64-Bit Bidirectional IX Bus Timing - Consecutive FastPort Receives, Different Ports, EOP, No Status, FP_READY_WAIT=0 .....	115
54	64-Bit Bidirectional IX Bus Timing - Consecutive FastPort Receives, Different Ports, EOP, No Status, FP_READY_WAIT=0, Cancelled Request ...	116
55	Consecutive Fetch Ready Flags, 1-2 MAC Mode (with No External Registered Decoder) - RDYBUS_TEMPLATE_CTL[10]=1 .....	117
56	Consecutive Fetch Ready Flags, 3+ MAC Mode (with External Decoder) - RDYBUS_TEMPLATE_CTL[10]=0 .....	117
57	Fetch Ready Flags, Get/Send Commands, 3+ MAC Mode (with External Registered Decoder) - RDYBUS_TEMPLATE_CTL[10]=0 .....	118
58	Ready Bus Control Timing, Fetch Ready Flags - Flow Control - Fetch Ready Flags, 1-2 MAC Mode (with No External Registered Decoder) - RDYBUS_TEMPLATE_CTL[10]=1 .....	118
59	Ready Bus Control Timing, Fetch Ready Flags - Flow Control - Fetch Ready Flags, 3+ MAC Mode (with External Registered Decoder) - RDYBUS_TEMPLATE_CTL[10]=0 .....	119
60	IX Bus Ownership Passing .....	120
61	SRAM SCLK Signal AC Parameter Measurements .....	120
62	SRAM Bus Signal Timing .....	122
63	Pipelined SRAM Read Burst of Eight Longwords .....	124
64	Pipelined SRAM Write Burst of Eight Longwords .....	124
65	Pipelined SRAM Read Burst of Four From Bank 0 Followed by Write Burst of Four From Bank 8 .....	125
66	Pipelined SRAM Longword Write Followed by 2 Longword Burst Read Followed by 4 Longword Burst Write .....	126
67	Flowthrough SRAM Read Burst of Eight Longwords .....	127
68	BootROM Read .....	128
69	BootROM Write .....	129
70	Pipelined SRAM Two Longword Burst Read Followed by BootROM Write .....	130
71	SRAM SlowPort Read .....	131

72	SRAM SlowPort Write .....	132
73	SRAM SlowPort RDY# .....	133
74	Pipelined SRAM Two Longword Burst Read Followed By SlowPort Write .....	134
75	SDCLK AC Timing Diagram .....	135
76	SDRAM Bus Signal Timing .....	136
77	SDRAM Initialization Sequence .....	139
78	SDRAM Read Cycle .....	140
79	SDRAM Write Cycle .....	140
80	SDRAM Read-Modify-Write Cycle .....	141
81	IXP1200 Part Marking .....	142
82	432-Pin HL-BGA Package - Bottom View .....	143
83	IXP1200 Side View.....	143
84	IXP1200 A-A Section View.....	143

## Tables

1	64-bit IX Bus Receive Remainder Cycles, No Status Transfer .....	14
2	64-bit IX Bus Receive Remainder Cycles, with Status Transfer .....	14
3	32-bit IX Bus Receive Remainder Cycles, No Status Transfer .....	14
4	32-bit IX Bus Receive Remainder Cycles, with Status Transfer .....	14
5	SDRAM Configurations .....	17
6	SRAM Configurations.....	20
7	BootROM x32 Sample Configurations .....	20
8	BootROM x16 Sample Configurations .....	20
9	PCI Configuration Options.....	22
10	Signal Type Abbreviations.....	26
11	Processor Support Pins.....	27
12	SRAM Interface Pins .....	28
13	SDRAM Interface Pins .....	30
14	IX Bus Interface Pins.....	32
15	General Purpose I/Os.....	36
16	Serial Port (UART) Pins .....	36
17	PCI Interface Pins .....	37
18	Power Supply Pins .....	40
19	IEEE 1149.1 Interface Pins .....	41
20	Miscellaneous Test Pins.....	41
21	Pin Usage Summary .....	42
22	Pin Table in Pin Order .....	43
23	Pin Table in Alphabetical Order.....	47
24	64-Bit Bidirectional IX Bus, 1-2 MAC Mode.....	54
25	64-Bit Bidirectional IX Bus, 3+ MAC Mode (Shared IX Bus Operation Only in This Mode) .....	56
26	32-Bit Unidirectional IX Bus, 1-2 MAC Mode .....	59
27	32-bit Unidirectional IX Bus, 3+ MAC Mode.....	61
28	IX Bus Decode Table Listed by Operating Mode Type .....	62
29	Pin State During Reset.....	64
30	Absolute Maximum Ratings.....	67
31	Functional Operating Range .....	68
32	Typical and Maximum Power .....	68
33	Maximum and Typical Bus Loading Used for the Power Calculations .....	68

34	I1, I3, O1, O3, O4, and O5 Pin Types .....	70
35	I2 and O2 Pin Types .....	71
36	Overshoot/Undershoot Specifications .....	71
37	PXTAL Clock Inputs .....	72
38	66 MHz PCI Clock Signal AC Parameters .....	73
39	33 MHz PCI Clock Signal AC Parameters .....	74
40	33 MHz PCI Signal Timing .....	75
41	66 MHz PCI Signal Timing .....	75
42	Reset Timings Specification .....	76
43	IEEE 1149.1/Boundary-Scan Interface Timing .....	79
44	FCLK Signal AC Parameter Measurements .....	80
45	IX Bus Signals Timing .....	81
46	Signal Delay Derating .....	82
47	SRAM SCLK Signal AC Parameter Measurements .....	121
48	SRAM Bus Signal Timing .....	122
49	Signal Delay Deratings for $T_{val}$ and $T_{ctl}$ .....	123
50	SDCLK AC Parameter Measurements .....	135
51	SDRAM Bus Signal Timing Parameters .....	136
52	Signal Delay Deratings for $T_{val}$ and $T_{ctl}$ .....	137
53	IXP1200 Package Dimensions (mm) .....	144



## 1.0 Product Description

The Intel® IXP1200 Network Processor is a highly integrated, hybrid data processor that delivers high-performance parallel processing power and flexibility to a wide variety of networking, communications, and other data-intensive products. The IXP1200 is designed specifically as a data control element for applications that require access to a fast memory subsystem, a fast interface to I/O devices such as network MAC devices, and processing power to perform efficient manipulation on bits, bytes, words, and longword data.

The IXP1200 combines the popular StrongARM® processor with six independent 32-bit RISC data engines with hardware multithread support that combined, provide over 1 giga-operations per second. The Microengines contain the processing power to perform tasks typically reserved for high speed ASICs. In LAN switching applications, the six Microengines are capable of packet forwarding of over 3 million Ethernet packets per second at Layer 3. The StrongARM® processor can then be used for more complex tasks such as address learning, building and maintaining forwarding tables, and network management.

Figure 1. Block Diagram

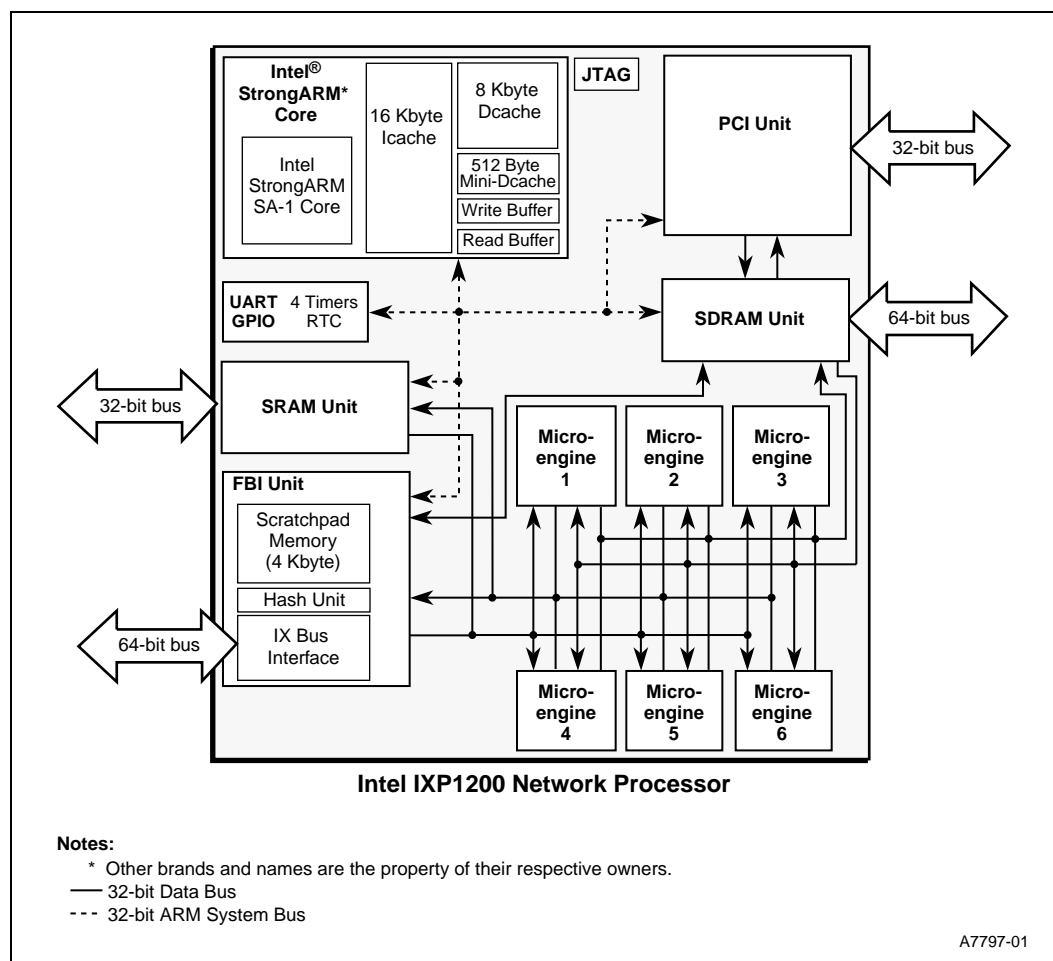

As shown in [Figure 2](#),

- The IXP1200 interfaces to a maximum of 256 Mbytes of SDRAM over a 64-bit data bus.
- A separate 32-bit SRAM bus supports up to 8 Mbytes of SSRAM and 8 Mbytes of BootROM. The SRAM Bus also supports memory-mapped I/O devices within a 2 Mbyte memory space.
- A 32-bit PCI interface supports interfacing with industry-standard PCI devices.
- The IX Bus, a flexible 64-bit or dual 32-bit interface, supports attachment of MACs, framers, custom logic devices, and an additional IXP1200.
- An asynchronous serial interface is supported for a debugger console over an RS-232 link.
- An IEEE 1149.1 interface is supported for Boundary Scan testing.

**Figure 2. IXP1200 System Block Diagram**

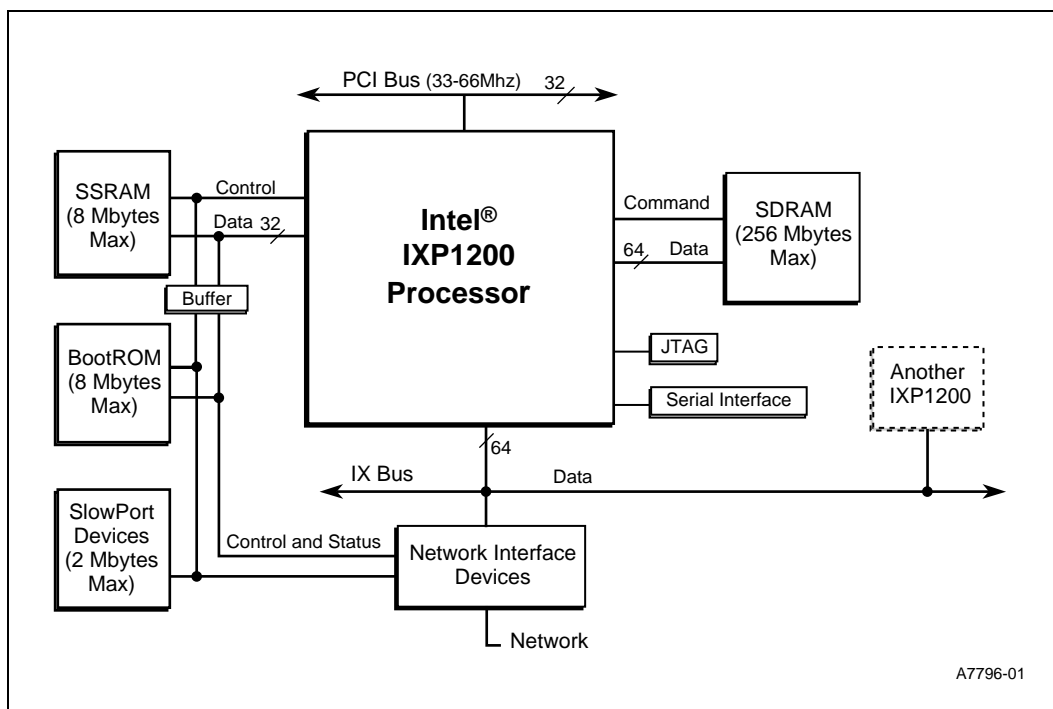

## 2.0 Introduction

---

Intel has created a new architecture, the IXP1200 Network Processor, to address the requirements of today's network equipment designers. The network processor is a fully programmable device which has been specifically designed to handle the high speed data manipulation requirements of networking equipment. It implements a symmetric array of six RISC data processors and a StrongARM\* processor, two memory interfaces, a PCI Interface, and an IX Bus Interface on a single chip.

The IXP1200 architecture was defined as a loosely-coupled, hybrid parallel processor set, integrating a StrongARM\* processor with an array of RISC data engines. Maximum throughput can be maintained by isolating them from memory accesses and the resulting latencies. This is done by decoupling the functional units for the IX Bus, PCI Bus, SDRAM, and SRAM interfaces from the execution pipelines through the extensive use of FIFO queues, and event task signaling. Semaphore mechanisms and thread-level support are implemented in hardware, allowing for zero-overhead context switching between threads executing on the Microengines.

Up to four thread-level tasks can be allocated per Microengine for a total of twenty-four threads in a single IXP1200. Multiple IXP1200 devices can be aggregated in a serial or parallel fashion, or in serial-parallel combinations to support diverse applications. Support chips from Intel can assist the system designer in using the IXP1200 in these multiprocessor designs.

A full suite of software tools is available from Intel for Microengine code development, simulation, and target hardware debugging. These tools can be used in conjunction with third-party StrongARM\* software tools and Realtime Operating Systems to build a complete embedded solution.

## 3.0 Related Documents

---

- *Intel® IXP1200 Network Processor Family Microcode Programmer's Reference Manual*
- *Intel® IXP1200 Network Processor Specification Update*
- *Intel® IXP1200 Network Processor Family Development Tools User's Guide*
- *Intel® IXP1200 Network Processor Family Hardware Reference Manual*
- *Intel® IXP1200 Network Processor Family Microcode Software Reference Manual*
- *ARM\* V4.0 Architecture Reference*

## 4.0 Conventions

---

- In all signal descriptions, an active low signal is indicated by a pound sign (#) in the signal name.
- In this and related IXP1200 documents, a word is equal to 16 bits, a longword is equal to 32 bits, and a quadword is equal to 64 bits. StrongARM\* processor documents and the ARM\* V4.0 Architecture Reference typically refer to a word as being equal to 32 bits, and a halfword as being equal to 16 bits.

## 5.0 Functional Units

---

### 5.1 StrongARM\* Core

The StrongARM\* core is the same industry standard 32-bit RISC processor as used in the Intel® StrongARM\* SA-1100. It is compatible with the StrongARM\* processor family currently used in applications such as network computers, PDAs, palmtop computers and portable telephones. The differentiating feature of the StrongARM\* processor is that it provides very high performance in a low-power, compact design. This makes it feasible to combine it with a collection of other dedicated execution units on the same silicon die.

The StrongARM\* core processor and six RISC Microengines provide the processing power required to forward greater than 3 million Ethernet packets per second through the IXP1200. A multi-IXP1200 system scales linearly so that a system comprised of eight IXP1200s can process over 24 million packets per second.

The designer can partition his/her application by allocating Microengines, threads, and StrongARM\* tasks. If necessary, multiple IXP1200 devices can be used to aggregate CPU MIPs, increase data bandwidth, increase port fanout and density, or some combination of all three metrics.

The StrongARM\* core operates at a frequency determined by programming the Phase-Locked Loop Configuration register (PLL\_CFG) and the maximum rated operating frequency of the IXP1200 device selected. The IXP1200 is currently available with an  $F_{core}$  operating frequency of 166, 200, or 232 MHz.

### 5.2 Microengines

Six 32-bit, multithreaded RISC Microengines perform data movement and processing without assistance from the StrongARM\* core. Each Microengine has four independent program counters, zero overhead context switching and hardware semaphores from other hardware units to ensure that each Microengine can be fully utilized. A Microengine's powerful ALU and shifter perform both ALU and shift operations in a single cycle. The instruction set was specifically designed for networking and communications applications that require bit, byte, word and longword operations to forward data quickly and efficiently. Each Microengine contains a large amount of local memory and registers: 4 Kbytes organized as 1024 by 32 bits of high-speed RAM Control Store for program execution, 128 32-bit General Purpose Registers, and 128 32-bit transfer registers to service the SRAM and SDRAM Units.

The Microengines operate at the core clock frequency ( $F_{core}$ ).

### 5.3 FBI Unit and the IX Bus

The FBI Unit is responsible for servicing fast peripherals, such as MAC-layer devices, on the IX Bus. This includes moving data to and from the IXP1200 Receive and Transmit FIFOs.

The IX Bus provides a 4.4 Gbps interface to peripheral devices. The IX Bus was specifically designed to provide a simple and efficient interface. The IX Bus can be configured as either a 64-bit bidirectional bus or as two 32-bit unidirectional buses. The maximum operating frequency of the IX Bus is 104 MHz.

Two IXP1200 devices can be placed on a single IX Bus in shared IX Bus mode. This option is supported only in 64-bit bidirectional mode.

The FBI Unit contains the Transmit and Receive FIFO elements, control and status registers (CSRs), a 4 Kbyte Scratchpad RAM, and a Hash Unit for generating 48- and 64-bit hash keys. It also contains the drivers and receivers for the IX Bus.

The IX Bus consists of 64 data pins, 23 control pins, and a clock input pin. A sideband bus operating in parallel to the IX Bus, called the Ready Bus, consists of eight additional data pins and five control pins.

The Ready Bus is synchronous to the IX Bus clock, but operation is controlled by a programmable hardware sequencer. Ready Bus cycles are separate and distinct from IX Bus cycles. Up to twelve sequencer commands are loaded at chip initialization time, and run in a continuous loop. The commands can consist of sampling FIFO status for the IX Bus devices, sending Flow Control messages to MAC devices, and reads/writes to other IXP1200 devices as required by the application design. Refer to the *IXP1200 Network Processor Hardware Reference Manual* for specific details on using the Ready Bus.

### 5.3.1 IX Bus Access Behavior

There are two basic modes of IX Bus operation. This is a configuration option only and is not intended to be used “on the fly” to switch between modes.

- 64-Bit Bidirectional Mode

The entire 64-bit data path FDAT[63:0] is used for reads or writes to IX Bus devices. The IXP1200 always drives and receives all 64 bits of the IX Bus in this mode. Valid bytes are indicated on the FBE#[7:0] signals driven by the IXP1200 during writes and by the IX Bus slave device on reads.

- 32-Bit Unidirectional Mode

The IX Bus is split into independent 32-bit transmit and 32-bit receive data paths. Transmit data is driven on FDAT[63:32] and receive data is input on FDAT[31:0]. In this mode, the transmit path is always driven. The receive path is an input during receive cycles and driven by the IXP1200 during device reset cycles or during prolonged idle time on the bus. Valid bytes are identified for the transmit path by the FBE#[7:4] signals. Valid bytes are identified for the receive path by the FBE#[3:0] signals.

Each basic mode has two additional modes depending on the number of IX Bus devices and ports being used: 1-2 MAC mode for one or two slave devices, and 3+ MAC mode when using three to seven slave devices. Bus timing and the functions of the IX Bus signals are slightly different in each mode. These functional definitions per IX Bus mode are listed in [Section 6.6](#) and [Section 6.7](#).

In addition, a shared IX Bus mode is supported in 64-bit bidirectional mode. Refer to the list at the bottom of [Table 25](#) for the signals that the IX Bus masters must drive and IX Bus slaves must tri-state.

The IX Bus and Intel devices using the IX Bus, such as the 21440 and IXF1002, observe a pipelined bus protocol. When receive transfers are terminated early, the pipeline continues to cause several extra bus cycles depending on when the EOP/EOP\_RX signal was asserted. Data is a “don’t

care” for these trailing bus cycles, except in the case of a status transfer where the IX Bus burst includes a possible status transfer if the device were programmed to support it. Slave devices must drive valid logic levels on the FDAT data pins during these cycles.

The tables below show the number of total IX Bus data cycles that will occur for a burst with EOP/EOP\_RX asserted at specific clocks for 64-bit and 32-bit IX Bus modes. In each case, the tables show IX Bus cycles with and without the optional status transfer cycle. Refer to the IX Bus Protocol Timing diagrams (Figure 21 through Figure 54) when interpreting these tables.

**Table 1. 64-bit IX Bus Receive Remainder Cycles, No Status Transfer**

EOP/EOP_RX signaled on this cycle:	1	2	3	4	5	6	7	8
# of bus cycles in burst:	5	6	7	8	8	8	8	8
# of Don't Care cycles:	4	4	4	4	3	2	1	0

**Table 2. 64-bit IX Bus Receive Remainder Cycles, with Status Transfer**

EOP/EOP_RX signaled on this cycle:	1	2	3	4	5	6	7	8
# of bus cycles in burst:	5	6	7	8	8	8	8	8
Status transfer	1	1	1	1	1	1	1	Note 1
# of Don't Care cycles:	3	3	3	3	2	1	0	0

**NOTE:**

1. Status transfer occurs on a subsequent IX Bus status cycle.

**Table 3. 32-bit IX Bus Receive Remainder Cycles, No Status Transfer**

EOP/EOP_RX signaled on this cycle:	1	2	3	4	5	6	7	8	9	10	11	12	13	14	15	16
# of bus cycles in burst:	5	6	7	8	9	10	11	12	13	14	15	16	16	16	16	16
# of Don't Care cycles:	4	4	4	4	4	4	4	4	4	4	4	4	3	2	1	0

**Table 4. 32-bit IX Bus Receive Remainder Cycles, with Status Transfer**

EOP/EOP_RX signaled on this cycle:	1	2	3	4	5	6	7	8	9	10	11	12	13	14	15	16
# of bus cycles in burst:	5	6	7	8	9	10	11	12	13	14	15	16	16	16	16	16
Status transfer	32-bit status	1	1	1	1	1	1	1	1	1	1	1	1	1	1	Note 1
	64-bit status	2	2	2	2	2	2	2	2	2	2	2	2	2	2	
# of Don't Care cycles:	3	3	3	3	3	3	3	3	3	3	3	3	2	1	0	0

**NOTE:**

1. Status transfer occurs on one or two subsequent IX Bus cycles.

In both 32-bit and 64-bit modes, all of the associated FBE# signals (FBE#[7:4] in 32-bit mode and FBE#[7:0] for 64-bit mode) are driven low on a transmit. The last bus transfer, identified by the assertion of EOP/EOP\_RX in 64-bit mode or by TK\_REQ\_IN/EOP\_TX in 32-bit mode, indicates the number of valid bytes of this last transfer by driving only the valid FBE# signals.

Similarly for receive cycles, in both 32-bit and 64-bit modes, all associated FBE# signals must be driven low by the peripheral or MAC device. The FBE# signals must identify the number of valid bytes on the last transfer driven with EOP/EOP\_RX. The IXP1200 uses this information to update the RCV\_CTL register's Valid Bytes field. Driving fewer than the four or eight FBE#, except for the last transfer with EOP/EOP\_RX, may cause undefined behavior.

### 5.3.1.1 Reset and Idle Bus Considerations

While the IXP1200 is in reset, or when the IX Bus is idle for at least 4 FCLK cycles and no bus requests are pending, the IXP1200 drives the pins listed below. This is done so that the bus is not left in a high-Z state for a prolonged period of time. This allows the designer to avoid the use of keeper resistors on the pins to maintain valid levels.

FDAT[63:0]  
FBE#[7:0]  
FPS[2:0]  
TXASIS/TXERR  
RDYBUS[7:0]  
RDYCTL#[3:0]  
RDYCTL#[4]/FC\_EN1#/RXPEN#  
EOP/EOP\_RX  
SOP/SOP\_RX  
TK\_REQ\_IN/EOP\_TX  
TK\_REQ\_OUT/SOP\_TX  
RXFAIL

In shared IX Bus mode, pullups should be used on PORTCTL#[3:0], FPS[2:0], and TXASIS/TXERR to maintain valid logic levels during bus exchanges.

In configurations where two IXP1200s are in Shared IX Bus Mode, the IXP1200s must be reset synchronously, preferably with the same signal driving RESET\_IN#. During reset, the IXP1200s drive the pins listed above to identical logic states thereby avoiding logic state contention. If the two devices are not reset synchronously, bus contention could result if one of the devices is held in reset while the alternate device assumes the role of initial IX Bus owner and begins driving transactions. This would result in obvious bus malfunction, and over time could affect device reliability due to resulting high current conditions in the device.

## 5.4 SDRAM and SRAM Units

The IXP1200 supports two high performance memory units. The SRAM Unit provides fast memory that can be used to store look-up tables. The SDRAM Unit provides lower cost memory for forwarding information and transmit queues. Both units contain features that improve memory bandwidth utilization.

### 5.4.1 SDRAM Unit

The IXP1200 provides an SDRAM Unit to access low cost, high bandwidth memory for mass data storage. The StrongARM® core address space allows up to 256 Mbytes of SDRAM to be addressed. The SDRAM interface operates at half the core frequency ( $0.5 * F_{core}$ ), providing a peak bandwidth of 928 Mbytes per second at 232 MHz.

Bus cycles are generated by requests from the PCI Unit including PCI DMA cycles, the StrongARM® core, and the Microengines.

The SDRAM is operated by commands that are loaded into command queues within the unit. The SDRAM Unit decodes the command, reads or writes the data, then deletes the command from the head of the queue. The read and write sources may be SDRAM memory locations, transfer registers, or the Transmit and Receive FIFOs in the FBI Unit. Refer to the *IXP1200 Network Processor Family Hardware Reference Manual* for details on how these requests are queued, prioritized, and serviced by the SDRAM Unit.

SDRAM should have an access time ( $t_{ac}$ ) of 6 ns or less (CAS latency = 2), PC100 compatible.

Figure 3 details the major components of the SDRAM Unit.

Figure 3. SDRAM Unit Block Diagram

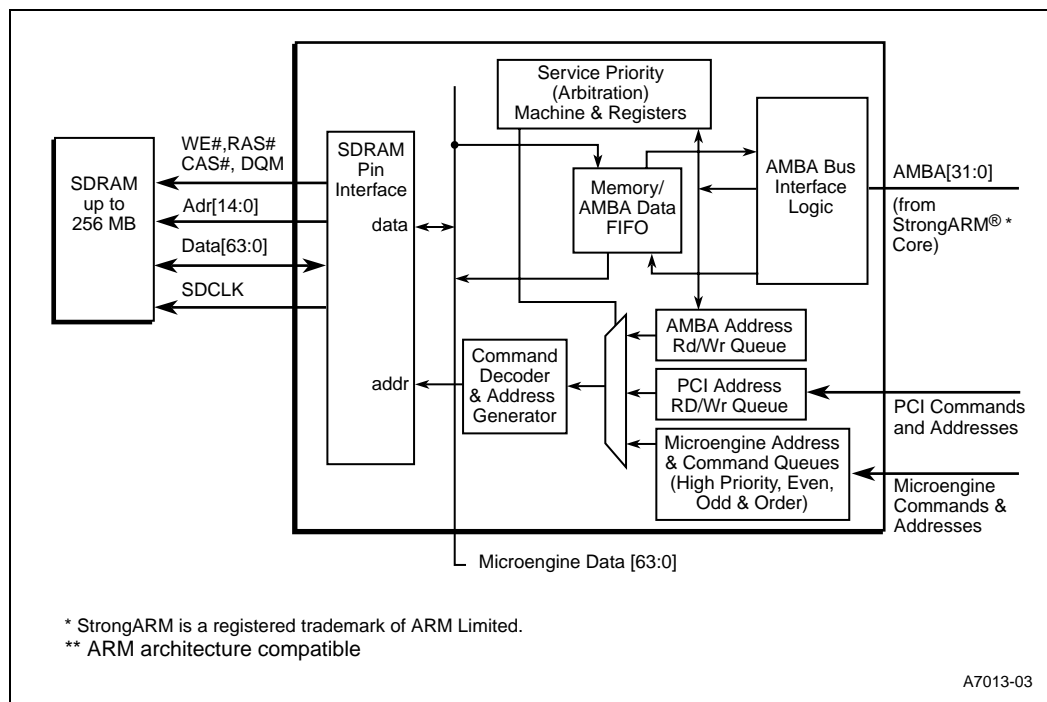

The SDRAM Bus consists of 15 row/column address bits, 64 data bits, RAS#, CAS#, write enable, DQM control, and a synchronous output clock running at one-half the IXP1200 core frequency ( $0.5 * F_{core}$ ).

The PCI, Microengines, and StrongARM® core require single byte, word, and longword write capabilities. The SDRAM Unit supports this using a read-modify-write technique. As data is written from the PCI or StrongARM® core to SDRAM, a quadword is read from SDRAM. The



IXP1200 then updates only the bytes that were enabled and writes the entire quadword of data back to SDRAM memory. (Note that the bytes do not have to be consecutive.) These three steps are performed automatically.

### 5.4.2 SDRAM Bus Access Behavior

- The number of quadwords transferred by the SDRAM Unit is determined by the requesting interface (StrongARM\* core, Microengine, or PCI). The SDRAM Unit may reorder SDRAM accesses for best performance.
- Accesses are always quadword (64-bit) cycles on the SDRAM Bus.
- Accesses from the StrongARM\* core.
  - Byte, word, and longword accesses generated from the StrongARM\* core result in Read-Modify-Write cycles to SDRAM space.
  - Consecutive longword writes over the AMBA Bus to the same quadword address are buffered and aggregated into quadword writes to SDRAM.
  - Read accesses using the Prefetch Memory address space allow the SDRAM Unit to prefetch quadword data to be supplied to the AMBA Bus using 32-bit burst cycles.
- Accesses from the Microengines.
  - The **sdram** microinstruction defines the number of 64-bit accesses to make, with up to 16 quadwords with one instruction.
  - Only quadword accesses are supported. Less than 8 bytes can be written when using the byte mask within an instruction, but result in Read-Modify-Write cycles.

### 5.4.3 SDRAM Configurations

Table 5. SDRAM Configurations

Total Memory	# of Chips	Size DRAM	Configuration (per bank)	Internal Banks	Bank Bits	RAS Bits	CAS Bits
8 Mbytes	4	16 Mbit	512 K x 16-bit	2	1	11	8
16 Mbytes	8	16 Mbit	1 M x 8-bit	2	1	11	9
32 Mbytes	4	64 Mbit	2 M x 16-bit	2	1	13	8
64 Mbytes	8	64 Mbit	4 M x 8-bit	2	1	13	9
32 Mbytes	4	64 Mbit	1 M x 16-bit	4	2	12	8
64 Mbytes	8	64 Mbit	2 M x 8-bit	4	2	12	9
64 Mbytes	4	128 Mbit	2 M x 16-bit	4	2	12	9
128 Mbytes	8	128 Mbit	4 M x 8-bit	4	2	12	10
128 Mbytes	4	256 Mbit	4 M x 16-bit	4	2	13	9
256 Mbytes	8	256 Mbit	8 M x 8-bit	4	2	13	10

### 5.4.4 SRAM Unit

The IXP1200 provides an SRAM Unit for very high bandwidth memory for storage of lookup tables and other data for the packet processing Microengines. The SRAM Unit controls the SRAM (up to 8 Mbytes), BootROM (up to 8 Mbytes) for booting, and 2 Mbytes of SlowPort address space for peripheral device access. The I/O signal timing is determined by internal address decodes and configuration registers for the BootROM and SlowPort address regions. The SRAM Unit includes an 8 entry Push/Pop register list for fast queue operations, bit test, set and clear instructions for atomic bit operations, and an 8 entry CAM for Read Locks.

The SRAM interface operates at one-half the IXP1200 core frequency ( $0.5 * F_{core}$ ).

The SRAM Unit supports both Pipelined Burst Double Cycle Deselect (DCD) and Flowthru SRAM types. Other SSRAM devices, including single cycle deselect, are not supported. The bus is also used to attach BootROM and can be used to interface other peripheral devices such as custom interface logic or MAC management ports. The SRAM interface provides three separate timing domains for the three device types: SRAM, BootROM, and Peripheral (also referred to as SlowPort access).

BootROM devices may be either 32 bits or 16 bits in width. This is determined by GPIO[3] during reset. When 16-bit BootROM devices are used, the maximum BootROM address space is reduced from 8 Mbytes to 4 Mbytes.

Figure 4 details the major components of the SRAM Unit.

Figure 4. SRAM Unit Block Diagram

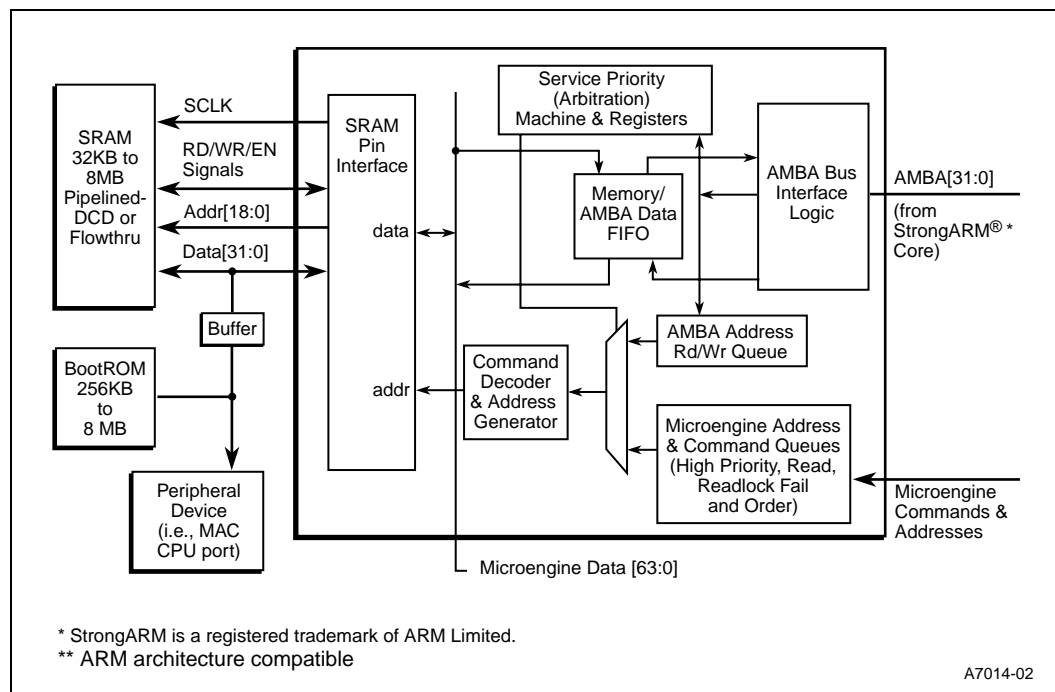

The SRAM Bus consists of 19 address bits, 32 data bits, 4 chip enable bits, 8 buffer and read/write control signals, a synchronous output clock (SCLK) running at one-half the IXP1200 core frequency, and a synchronous input clock (SCLKIN). When using Flowthru SRAM types, it is recommended to route the SCLK signal from the SRAMs back to the SCLKIN input. Routing this

trace identically to the DQ data signals will skew the SCLKIN slightly to track the return data trace propagation delay. When using Pipelined/DCD SRAMs, the SCLKIN input is not used and may be held inactive with a pulldown to GND to save power.

The SRAM Unit receives memory requests from seven sources: the StrongARM\* core and each of the six Microengines. Refer to the IXP1200 Hardware Reference Manual for details on the prioritization and queues provided for servicing these requests.

The IXP1200 supports the use of an optional asynchronous ready input for flexibility in interfacing memory-mapped I/O devices to the SRAM Slowport region. This will allow the I/O device to add wait-states to IXP1200 I/O accesses. This function is supported on the HIGH\_EN#/RDY# pin. An I/O device must drive HIGH\_EN#/RDY# with a wired-OR open drain buffer configuration, and only drive the pin when the I/O device is selected.

To use the RDY# pin function, it must be enabled by setting SRAM\_CSR[19]=1. The RDY# Pause State Value field located in register SRAM\_SLOW\_CONFIG[23:16] must be programmed with the state value at which you choose to pause the internal wait-state logic. This pause state relates to the other timing parameters programmed into the SRAM\_SLOW\_CONFIG and SRAM\_SLOWPORT\_CONFIG register fields. See [Figure 73](#) which illustrates this example. The SCC value is the total number of core clocks for the I/O cycle, and the SRWA, SCEA, SRWD, and SCED values specify the RD/WR and Chip Enable signal assert and deassert times. When the I/O cycles begins, the SCC value is loaded into the internal state counter and is decremented on each core clock tick (twice the SCLK frequency). When the state counter reaches the RDY# Pause State Value, it will remain in that state until the HIGH\_EN#/RDY# pin is sampled LOW, allowing the state counter to resume its decrement operation. The HIGH\_EN#/RDY# must be driven for at least two SCLK periods to be sampled properly by the IXP1200.

The RDY# Pause State must also occur at a minimum of 5 core clock periods prior to the SRWD state to be recognized. A RDY# Pause State value of SRWD+5 (Decimal 10, Hexidecimal A) is used in this example.

In this example, 6 additional core clock “wait-states” are inserted. If the RDY# input is synchronous to SCLK and it meets the specified setup and hold times, the resulting number of wait states will be predictable. However, if the RDY# input is asynchronous to SCLK, the number of wait-states the IXP1200 inserts could vary by +/- 2 core clock periods.

#### 5.4.4.1 SRAM Types Supported

Pipeline Burst DCD (double cycle deselect) type: tKQmax=4.2 ns, 3.3 V.

Flowthru type: tKQmax= 9 ns, 3.3 V.

**Note:** Other SSRAM devices, including single cycle deselect, are not supported.

### 5.4.4.2 SRAM Configurations

Table 6. SRAM Configurations

Total Memory	# of Chips (Maximum of 8)	Size of SRAM	Device Organization
1 Mbytes	8	1 Mbit	32 K x 32-bit
2 Mbytes	8	2 Mbit	64 K x 32-bit
2 Mbytes	8	2 Mbit	128 K x 16-bit
4 Mbytes	8	4 Mbit	128 K x 32-bit
4 Mbytes	8	4 Mbit	256 K x 16-bit
8 Mbytes (maximum)	8	8 Mbit	256 K x 32-bit

### 5.4.4.3 BootROM Configurations

Table 7. BootROM x32 Sample Configurations

Total Memory	# of Chips (Maximum of 8)	Size of Boot ROM	Device Organization
512 Kbytes	2	2 Mbit	128 K x 16-bit
2 Mbytes	8	2 Mbit	128 K x 16-bit
4 Mbytes	8	4 Mbit	256 K x 16-bit
6 Mbytes	6	8 Mbit	512 K x 16-bit
8 Mbytes	8	8 Mbit	512 K x 16-bit

Table 8. BootROM x16 Sample Configurations

Total Memory	# of Chips (Maximum of 8)	Size of Boot ROM	Device Organization
256 Kbytes	1	2 Mbit	128 K x 16-bit
512 Kbytes - 4 Mbytes	2 - 8	2 Mbit	128 K x 16-bit
512 Kbytes	1	4 Mbit	256 K x 16-bit
1 Mbytes - 4 Mbytes	2 - 8	4 Mbit	256 K x 16-bit
1 Mbytes	1	8 Mbit	512 K x 16-bit
2Mbytes - 4 Mbytes	2 - 4	8 Mbit	512 K x 16-bit

### 5.4.4.4 SRAM Bus Access Behavior

- The SRAM controller within the IXP1200 will never initiate automatic bursting. Bursting is controlled by the requestor (StrongARM\* core or Microengine) depending on the type and number of SRAM accesses needed.
- Accesses are always longword 32-bit cycles on the SRAM Bus.
- The IXP1200 always drives the address for each data cycle. No external address generation or address advance control to SRAM devices is required.

- Accesses from the StrongARM\* core:
  - Byte, word, and longword accesses generated from the StrongARM\* core are supported.
  - Bit operations are supported via StrongARM\* core accesses to the SRAM Alias Address Space to perform the same operations as a Microengine can accomplish implicitly in a microinstruction (Push, Pop, Bit Test and Set, CAM operations, Lock/Unlock, etc.).
  - Bit, byte, and word writes result in Read-Modify-Write cycles.
  - Declare memory-mapped I/O as non-cachable to prevent line fill burst cycles, and disable caching and write buffering to ensure I/O device coherency.
  - For best performance, use longword accesses to avoid Read-Modify-Write cycles on the SRAM Bus that occur with byte and word accesses.
- Accesses from the Microengines:
  - The **sram** microinstruction defines the number of 32-bit accesses to make, up to 8 longwords with one Microengine command.
  - Only bit and longword accesses are supported.
  - Bit write accesses result in Read-Modify-Write cycles.
  - Unlike the StrongARM\* core, the Microengine microinstruction allows you to perform bit operations within the instruction (Push, Pop, Bit Test and Set, CAM operations, Lock/Unlock, etc.).

## 5.5 PCI Unit

The PCI Unit provides an industry standard 32-bit PCI Bus to interface to PCI peripheral devices such as host processors and MAC devices. The PCI Unit supports operating speeds from DC up to 66 MHz, and supports *PCI Local Bus Specification, Revision 2.2*. This unit contains:

- Arbitration logic to support up to three PCI Bus masters,
- PCI Intelligent I/O (I<sub>2</sub>O),
- Two DMA channels, and
- Four 24-bit timers.

Refer to the *Intel® IXP1200 Network Processor Family Hardware Reference Manual* for details on PCI Bus behavior for Target (Slave) and Initiator (Master) modes, configuration and register definitions.

The PCI interface is specified to operate from DC up to 66 MHz. Above 33 MHz operation, two PCI devices are supported only, the IXP1200 and a second PCI device. To increase the number of PCI devices supported or to add connectors to the bus at the higher PCI Bus speeds, a PCI-to-PCI bridge device, such as the Intel 21150, 21152, or 21153 is required.

Both PCI Initiator and Target cycles are supported. As a target device, the IXP1200 responds as a Medium Speed device asserting DEVSEL# two PCI\_CLK cycles after FRAME# is asserted.

### 5.5.1 PCI Arbitration and Central Function Support

The IXP1200 contains an optional arbiter to support up to three PCI Bus masters. This includes the IXP1200 plus two external PCI Bus master devices. The external masters are supported by two request signals, REQ#[1:0], and two grant signals GNT#[1:0].

The IXP1200 can also provide PCI Central Function support. In this configuration, the IXP1200:

- Drives the PCI Reset signal, PCI\_RST#, as an output,
- Monitors the PCI System Error input signal, SERR#, and
- Provides Bus Parking where the IXP1200 is the default PCI Bus master, and it drives valid logic levels on the PCI A/D, C/BE, and PAR pins during reset and idle PCI Bus conditions.

Two configuration pins, PCI\_CFN[1:0], are sampled at the rising edge of RESET\_IN# to determine the PCI configuration (see [Table 9](#)).

**Table 9. PCI Configuration Options**

PCI_CFN[1:0]	PCI FUNCTION
00	Central Function and Arbitration disabled.
10	Reserved for future use.
01	Reserved for future use.
11	Central Function and Arbitration enabled.

### 5.6 Device Reset

The IXP1200 can be reset by the following:

- Hardware Reset via RESET\_IN# pin
- Software Reset by StrongARM\* core or by PCI device write to the IXP1200\_RESET register
- PCI Reset via the PCI\_RST# pin
- Watchdog Timer expiration

[Figure 5](#) illustrates details of the internal reset function logic.

Figure 5. Reset Logic

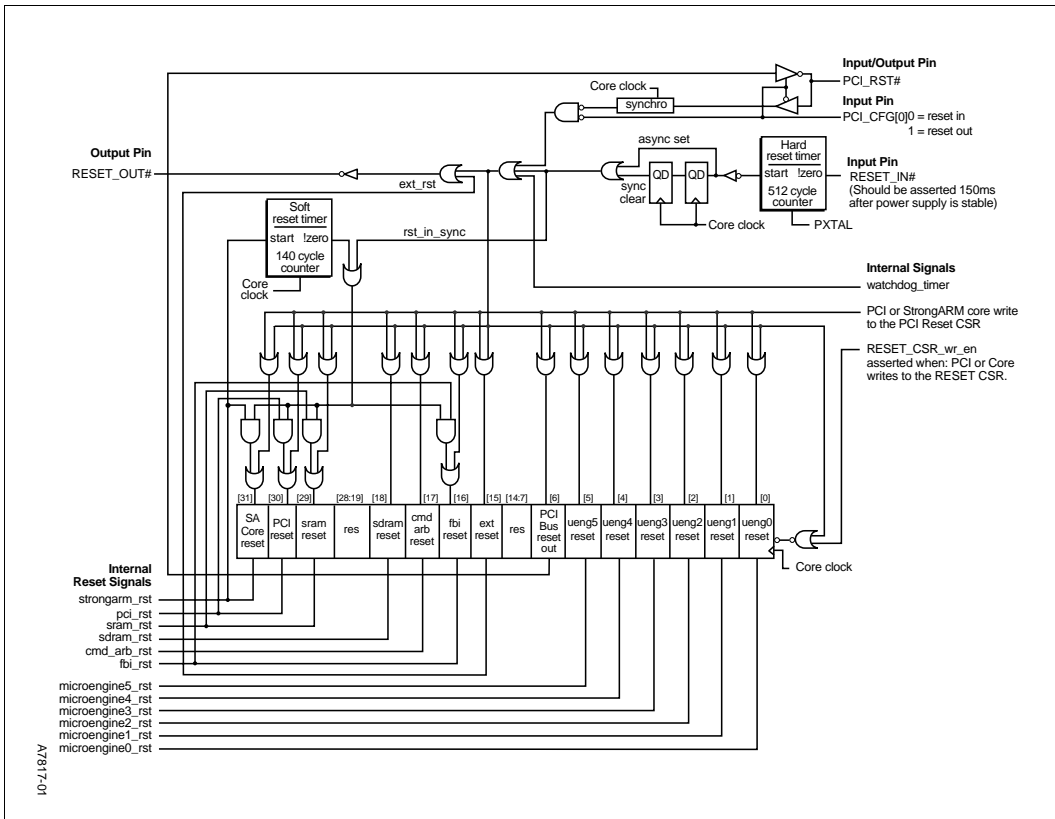

A7817-01

### 5.6.1 Hardware Initiated Reset

The IXP1200 provides the RESET\_IN# pin so that an external device can reset the IXP1200. Asserting this pin resets the internal functions and generates an external reset via the RESET\_OUT# pin.

Upon power-up, RESET\_IN# must remain asserted for 150 ms after VDD and VDDX are stable to properly reset the IXP1200 and ensure that the PXTAL clock input and PLL Clock generator are stable.

While RESET\_IN# is asserted, the processor is held reset. When RESET\_IN# is released, the StrongARM\* processor begins execution from SRAM address 0 after 512 PXTAL cycles. If RESET\_IN# is asserted while the StrongARM\* core is executing, the current instruction terminated abnormally and the on-chip caches, MMU, and write buffer are disabled.

The RESET\_OUT# signal remains asserted until deasserted by the StrongARM\* core. The StrongARM\* core deasserts the signal by writing bit 15 of the IXP1200\_RESET register.

### 5.6.2 Software Initiated Reset

The StrongARM\* core or an external PCI Bus master can reset specific functions in the IXP1200 by writing to the IXP1200\_RESET register. In most cases, only the individual Microengines are reset and the external RESET\_OUT# pin will be asserted via this register. The ability to reset the other functions is provided for debugging. The SRAM Unit is always reset when the StrongARM\* core is reset. To ensure a proper reset, the StrongARM\* core and the SRAM Unit are held in reset for 140 system clock cycles after RESET\_IN# is deasserted. The other functions that can be reset via the IXP1200\_RESET register are properly reset when consecutive writes are performed to assert and deassert the reset.

### 5.6.3 PCI Initiated Reset

The IXP1200 can be reset by an external PCI Bus master when the IXP1200 is not the PCI Central Function and arbiter device (PCI\_CFG[1:0] = 00) and PCI\_RST# is an input. The entire IXP1200 is reset during a PCI Initiated Reset. When the IXP1200 is assigned as the PCI Central Function and arbiter device (PCI\_CFG[1:0] = 11), the IXP1200 drives PCI\_RST# as an output to the other devices on the PCI Bus.

### 5.6.4 Watchdog Timer Initiated Reset

The IXP1200 provides a watchdog timer that can reset the StrongARM\* core. The StrongARM\* core should be programmed to reset the watchdog timer periodically to ensure that the timer does not expire. If the watchdog timer expires, it is assumed the StrongARM\* core has ceased executing instructions properly. The reset generated by the Watchdog Timer will reset each of the functions in the IXP1200.



## 6.0 Signal Description

### 6.1 Pinout Diagram

Figure 6. Pinout Diagram

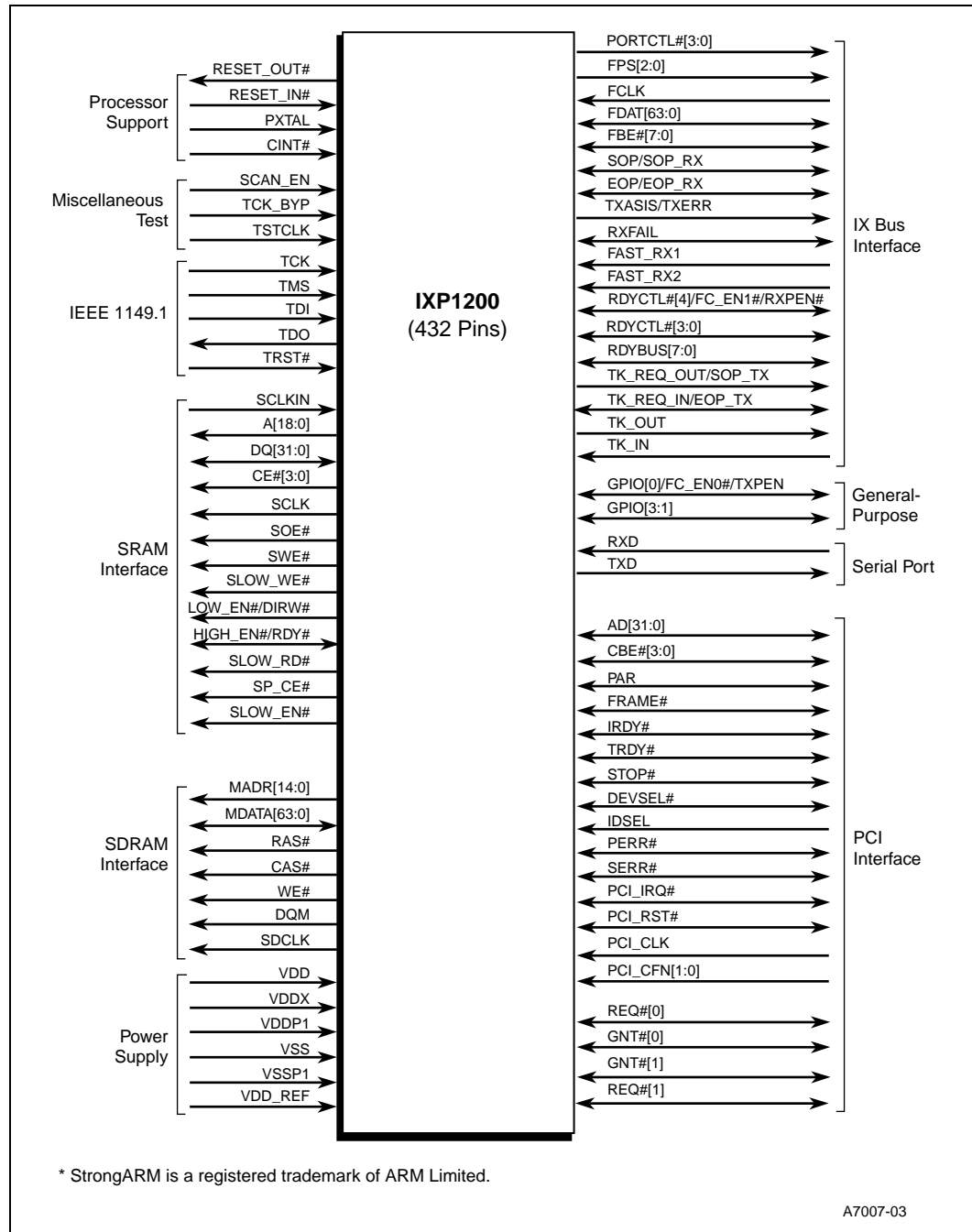

## 6.2 Pin Type Legend

The IXP1200 signals are categorized into one of several groups: Processor Support, Miscellaneous/Test, IEEE 1149.1, SRAM Interface, SDRAM Interface, IX Bus Interface, General Purpose, Serial Port, and PCI Interface.

Table 10 defines the signal type abbreviations used in the Pin Description section.

**Table 10. Signal Type Abbreviations**

Signal Type	Description
I	Standard input only. There are three types of inputs (I1,I2, and I3) for the IXP1200. Refer to <a href="#">Table 34</a> and <a href="#">Table 35</a> for more information.
O	Standard output only. There are 5 types of outputs (O1,O2,O3,O4, O5) for the IXP1200. Refer to <a href="#">Table 34</a> and <a href="#">Table 35</a> for more information.
TS	Tri-state output.
STS	Sustained tri-state. Active low signal owned and driven by one and only one agent at a time. The agent that drives this pin low must drive it high for at least one clock before letting it float. A new agent cannot start driving this signal any sooner than one clock after the previous owner tri-states it. A pullup is required to sustain the inactive state until another agent drives it, and it must be provided by the central resource (that is, on a PC board).
P	Power supply.
OD	Standard open drain allows multiple devices to share as a wire-OR. A pullup is required to sustain the inactive state until another agent drives it, and it must be provided by the central resource.

## 6.3 Pin Description, Grouped by Function

### 6.3.1 Processor Support Pins

Table 11. Processor Support Pins

Processor Support Signal Names	Pin #	Type	Total	Pin Descriptions
PXTAL	B4	I1	1	Input connection for system oscillator. Typically 3.6864 MHz. Drives internal PLL clock generator.
CINT#	Y28	I1	1	Level-sensitive interrupt input to the StrongARM* core.
RESET_OUT#	A5	O4	1	IXP1200 System Reset Output. Asserted when: <ul style="list-style-type: none"> <li>• RESET_IN# is asserted.</li> <li>• PCI Central Function and arbiter disabled (PCI_CFN[1:0]=00) and PCI_RST# is asserted.</li> <li>• A soft reset is initiated.</li> <li>• The Watchdog Timer expires.</li> </ul> To deassert, write register IXP1200_RESET bit 15.
RESET_IN#	C6	I1	1	IXP1200 System Reset Input. If asserted, the IXP1200 will reset and will assert RESET_OUT#. If PCI Central Function and arbiter enabled (PCI_CFN[1:0]=11), PCI_RST# output will also be asserted.
Totals:			4	

## 6.3.2 SRAM Interface Pins

Table 12. SRAM Interface Pins

SRAM Interface Signal Names	Pin #	Type	Total	Pin Descriptions
A[18:0]	[18] A28 [17] B28 [16] D27 [15] E28 [14] D30 [13] D31 [12] E29 [11] F28 [10] E30 [9] E31 [8] F29 [7] F30 [6] F31 [5] G29 [4] H28 [3] G30 [2] G31 [1] H29 [0] J28	O4	19	Address outputs
DQ[31:0]	[31] H30 [30] J30 [29] J31 [28] K29 [27] L28 [26] K30 [25] K31 [24] L29 [23] M28 [22] L30 [21] L31 [20] M29 [19] N28 [18] M30 [17] M31 [16] N29 [15] N30 [14] N31 [13] P29 [12] R28 [11] P30 [10] R29 [9] R30 [8] R31 [7] T28 [6] T29 [5] T30 [4] T31 [3] U29 [2] U28 [1] V30 [0] V29	I1/O4	32	32 Bidirectional data signals

**Table 12. SRAM Interface Pins (Continued)**

SRAM Interface Signal Names	Pin #	Type	Total	Pin Descriptions
CE#[3:0] [3] [2] [1] [0]	A26 B26 C26 A27	O4	4	SRAM Bus chip enable outputs. Internally decoded from SRAM address. Valid during SRAM and BootROM accesses.
SCLK	W31	O3	1	SRAM clock output - Frequency is one half the speed of the core clock ( $\frac{1}{2} * F_{core}$ ).
SCLKIN	B24	I1	1	SRAM clock input, used to compensate for skew in data path when using Flowthru SRAMs. Must be connected to SCLK output when using Flowthru devices. Not used with Pipelined devices and should be pulled low.
SOE#	W30	O4	1	SRAM output enable.
SWE#	Y30	O4	1	SRAM write enable.
SLOW_WE#	W28	O4	1	Asynchronous interface write enable (BootROM or MAC devices).
LOW_EN#/DIRW#	D26	O4	1	Low order SRAM bank enable and buffer direction select for slow interface. When used as the buffer direction select: 0 = write and 1 = read.
HIGH_EN#/RDY#	C27	I1/O4	1	High-order SRAM bank enable output and Flash PROM/BootROM read enable or asynchronous Ready input from I/O devices. The pin function is determined by programming SRAM_CSR[19] = 1, which enables RDY# or SRAM_CSR[19] = 0, which enables the HIGH_EN# function. When using the RDY# function, I/O devices must drive this signal using a wired-OR configuration, which requires a pullup resistor on this pin. Note that this pin is driven as an output until SRAM_CSR[19] is set.
SLOW_EN#	Y29	O4	1	Slow device enable: 0 = Slow device (BootROM or SlowPort), 1=SRAM.
SP_CE#	W29	O4	1	Slow asynchronous interface chip enable output.
SLOW_RD#	Y31	O4	1	Slow asynchronous interface read enable output.
Totals:			65	

### 6.3.3 SDRAM Interface Pins

Table 13. SDRAM Interface Pins

SDRAM Interface Signal Names	Pin #	Type	Total	Pin Descriptions
MADR[14:0] [14] AK5 [13] AD1 [12] AC3 [11] AC2 [10] AC1 [9] AB3 [8] AA4 [7] AB2 [6] AB1 [5] AA3 [4] AA1 [3] Y3 [2] W4 [1] Y2 [0] Y1		O4	15	Multiplexed Row/Column address outputs.
MDATA[63:0] [63] AH6 [62] AJ5 [61] AL4 [60] AK4 [59] AH5 [58] AH2 [57] AH1 [56] AG3 [55] AF4 [54] AG2 [53] AG1 [52] AF3 [51] AF2 [50] AF1 [49] AE3 [48] AD4 [47] AE2 [46] AE1 [45] U4 [44] V2 [43] U3 [42] U2 [41] U1 [40] T4 [39] T3 [38] T2 [37] T1 [36] R3 [35] R4 [34] P2 [33] P3 [32] N1 [31] N2 [30] N3 [29] M1 [28] M2 [27] N4 [26] M3		I1/O1	64	64 Bidirectional data signals.

Table 13. SDRAM Interface Pins (Continued)

SDRAM Interface Signal Names	Pin #	Type	Total	Pin Descriptions
[25] L1 [24] L2 [23] M4 [22] L3 [21] K1 [20] K3 [19] J1 [18] J2 [17] J3 [16] H1 [15] H2 [14] J4 [13] H3 [12] G1 [11] G2 [10] H4 [9] G3 [8] F1 [7] F2 [6] F3 [5] E1 [4] E2 [3] F4 [2] E3 [1] D1 [0] D2				
RAS#	W2	O4	1	Row Address Select output. Precharge cycle indicated if asserted with WE#.
CAS#	W3	O4	1	Column Address Select output.
WE#	W1	O4	1	Write Enable output.
DQM	V3	O4	1	SDRAM data control output. SDRAMs use this signal to enable their data buffers to drive MDATA[63:0] on reads, or enable the SDRAM to accept input data from MDATA[63:0] for writes.
SDCLK	AD2	O3	1	SDRAM Clock output. Frequency is one half the speed of the core clock ( $\frac{1}{2} * F_{core}$ ).
Totals:			84	

### 6.3.4 IX Bus Interface Pins

Table 14. IX Bus Interface Pins

IX Bus Signal Names	Pin #	Type	Total	Pin Descriptions
FCLK	AB30	I3	1	IX Bus Clock input. All IX Bus transfers are synchronized to this clock. Typical operating frequency 33 MHz - 104 MHz.
PORTCTL#[3:0] [3] [2] [1] [0]	AC30 AC31 AB29 AA28	O1/TS	4	Port Control outputs. Used to select the transmit and/or receive mode for IX Bus devices, typically MAC devices. In 64-bit bidirectional IX Bus mode, this is a 4-bit bus used to indicate transmit or receive commands and device selects. In 32-bit unidirectional IX Bus mode, bits [1:0] are used to select the receive device and bits [3:2] are used to select the transmit device. In a shared IX Bus system, these pins will be tri-stated when passing ownership of the IX Bus.
FPS[2:0] [2] [1] [0]	AC29 AD31 AD30	O4/TS	3	MAC Port Select outputs. In 32-bit and 64-bit modes, these pins select one of eight MAC receive ports from the selected MAC device. See IX Bus control signal decode tables. In a shared IX Bus system, these pins will be tri-stated when passing ownership of the IX Bus.
FDAT[63:0] [63] [62] [61] [60] [59] [58] [57] [56] [55] [54] [53] [52] [51] [50] [49] [48] [47] [46] [45] [44] [43] [42] [41] [40] [39] [38] [37] [36] [35] [34] [33] [32] [31]	AC28 AD29 AE31 AE30 AF31 AF30 AF29 AG31 AG30 AF28 AG29 AH31 AH30 AH27 AK28 AL28 AJ27 AH26 AK27 AL27 AJ26 AK26 AL26 AJ25 AH24 AK25 AL25 AJ24 AH23 AK24 AL24 AJ23 AK23	I2/O5/ TS	64	IX Bus Data. One 64-bit bus in bidirectional IX Bus mode. Two 32-bit buses in unidirectional IX Bus mode where bits [63:32] are used for Transmit Data output and [31:0] are used for Receive Data input. In a shared IX Bus system, these pins will be tri-stated when passing ownership of the IX Bus.



Table 14. IX Bus Interface Pins (Continued)

IX Bus Signal Names	Pin #	Type	Total	Pin Descriptions
[30] [29] [28] [27] [26] [25] [24] [23] [22] [21] [20] [19] [18] [17] [16] [15] [14] [13] [12] [11] [10] [9] [8] [7] [6] [5] [4] [3] [2] [1] [0]	AL23 AJ22 AH21 AK22 AL22 AJ21 AH20 AK21 AL21 AJ20 AH19 AK20 AL20 AJ19 AK19 AL19 AJ18 AH17 AK18 AJ17 AK17 AL17 AH16 AJ16 AK16 AL16 AJ15 AH15 AK14 AJ14 AL13			
FBE#[7:0] [7] [6] [5] [4] [3] [2] [1] [0]	AK13 AJ13 AL12 AK12 AH13 AJ12 AL11 AK11	I2/O5/ TS	8	Bidirectional Byte Enables. 64-bit bidirectional IX Bus mode. Bits [7:0] indicate transmit and receive valid bytes on FDAT[63:0]. 32-bit unidirectional IX Bus mode. Bits [7:4] are used to indicate valid transmit bytes on FDAT[63:32] and bits [3:0] are used to indicate valid receive bytes on FDAT[31:0]. In a shared IX Bus system, these pins will be tri-stated when passing ownership of the IX Bus.
TXASIS/TXERR	AL10	O4/TS	1	Transmit As Is/Transmit Error output. TXASIS/TXERR states are output according to values programmed in the TFIFO control field. TXASIS value driven coincident with SOP/SOP_TX signal. TXERR value driven coincident with EOP/EOP_TX signal. In a shared IX Bus system, these pins will be tri-stated when passing ownership of the IX Bus.
RXFAIL	AK10	I1/O1/ TS	1	Receive Packet Failure. As input, asserted by a MAC device if a packet was received with errors. Mimics the behavior of EOP/EOP_RX to terminate an IX Bus cycle. As output, driven when no receive cycle in-progress. In a shared IX Bus system, these pins will be tri-stated when passing ownership of the IX Bus.
FAST_RX1	AH11	I1	1	Ready Input from Fast Port 0 (i.e., Gigabit port). Pulldown through 10 KOhms to VSS if not used.

Table 14. IX Bus Interface Pins (Continued)

IX Bus Signal Names	Pin #	Type	Total	Pin Descriptions
FAST_RX2	AJ10	I1	1	Ready Input from Fast Port 1 (i.e., Gigabit port). Pulldown through 10 KOhms to VSS if not used.
RDYCTL#[4]/ FC_EN1#/ RXPEN#	AK6	I1/O4/ TS	1	<p>In 64-bit Bidirectional IX Bus Mode:</p> <ul style="list-style-type: none"> <li>1-2 MAC mode: Used as an active low flow control enable for MAC 1 (GPIO[0]/FC_EN0#/TXPEN is used as a flow control enable for MAC 0).</li> <li>3+ MAC mode: Used in conjunction with RDYCTL#[3:0].</li> <li>In a shared IX Bus system the IXP1200 Ready Bus Master drives this pin. IXP1200 Ready Bus slave devices snoop this pin.</li> </ul> <p>In 32-bit Unidirectional Mode:</p> <ul style="list-style-type: none"> <li>1-2 MAC mode: Used as an active low flow control enable for MAC 1. GPIO[0]/FC_EN0#/TXPEN is used as a flow control enable for MAC 0.</li> <li>3+ MAC mode: Used as an active low enable for an external decoder for the PORTCTL[1:0] signals.</li> </ul>
RDYCTL#[3:0] [3] [2] [1] [0]	AL6 AJ7 AH8 AK7	I1/O4/ TS	4	<p>Bidirectional Ready Control signals.</p> <p>In 64-bit Bidirectional IX Bus Mode:</p> <ul style="list-style-type: none"> <li>1-2 MAC mode: Bits [3:0] are used to enable the transmit or receive FIFO Ready Flags.</li> <li>3+ MAC mode: The transmit and receive FIFO Ready, the flow control, and inter-processor communication enables are decoded from RDYCTL#[4:0].</li> <li>In a shared IX Bus system the IXP1200 Ready Bus Master drives this bus. IXP1200 Ready Bus slave devices snoop these pins as inputs.</li> </ul> <p>In 32-bit Unidirectional Mode:</p> <ul style="list-style-type: none"> <li>1-2 MAC mode: Bits [3:0] are used to enable the transmit or receive FIFO Ready Flags.</li> <li>3+ MAC mode: The transmit and receive FIFO ready and flow control enables are decoded from RDYCTL#[3:0].</li> </ul>
RDYBUS[7:0] [7] [6] [5] [4] [3] [2] [1] [0]	AL9 AK9 AJ9 AL8 AK8 AH9 AJ8 AL7	I1/O4	8	<p>8-Bit Bidirectional Ready Bus data.</p> <ul style="list-style-type: none"> <li>Inputs the Transmit and Receive Ready Flags from IX Bus devices.</li> <li>Outputs flow control data to IX Bus devices.</li> <li>Data bus for interprocessor communications.</li> </ul>
SOP/SOP_RX	AH12	I1/O4/ TS	1	<p>Start of Packet indication.</p> <ul style="list-style-type: none"> <li>Receive Start of Packet Input in 32-bit unidirectional IX Bus mode.</li> <li>Input/Output in 64-bit bidirectional IX Bus mode. SOP/SOP_RX is Transmit Start of Packet output according to values programmed in the TFIFO control field. Is Receive Start of Packet input during receive cycles.</li> <li>In a shared IX Bus system, this pin will be tri-stated when passing ownership of the IX Bus.</li> </ul>

Table 14. IX Bus Interface Pins (Continued)

IX Bus Signal Names	Pin #	Type	Total	Pin Descriptions
EOP/EOP_RX	AJ11	I1/O4/TS	1	End of Packet Indication. <ul style="list-style-type: none"> <li>Receive End of Packet Input in 32-bit unidirectional IX Bus mode.</li> <li>Input/Output in 64-bit bidirectional IX Bus mode. EOP/EOP_RX is Transmit End of Packet output according to values programmed in the TFIFO control field. Is Receive End of Packet input during receive cycles.</li> <li>In a shared IX Bus system, this pin will be tri-stated when passing ownership of the IX Bus.</li> </ul>
TK_REQ_OUT/SOP_TX	AJ6	O4	1	Transmit Start Of Packet Indication/Token Request Output. <ul style="list-style-type: none"> <li>Output in 32-bit unidirectional IX Bus modes. TK_REQ_OUT/SOP_TX is Transmit Start of Packet output during transmit according to values programmed in the TFIFO control field.</li> <li>64-bit bidirectional 3+ MAC shared bus mode, is IX Bus Token Request output indication when high.</li> <li>64-bit bidirectional 1-2 MAC mode, not used and should be left unconnected.</li> </ul>
TK_REQ_IN/EOP_TX	AL5	I1/O4	1	Transmit End Of Packet/Token Request Input. <ul style="list-style-type: none"> <li>32-bit unidirectional IX Bus modes TK_REQ_IN/EOP_TX is Transmit End of Packet output according to values programmed in the TFIFO control field.</li> <li>64-bit bidirectional IX Bus modes, single-chip operation, this input should be pulled high.</li> <li>In shared IX Bus mode, an input indicating IX Bus Token Request Pending from another device when high.</li> </ul>
TK_OUT	AA29	O1	1	Token Output. Used to pass ownership of the IX Bus in a shared IX Bus system in 64-bit bidirectional IX Bus mode. In 32-bit unidirectional mode this bit is unused and should be left unconnected.
TK_IN	AB31	I1	1	Token Input. 64-bit bidirectional IX Bus Mode: A high-to-low transition indicates that this device has been given ownership of the IX Bus in a shared IX Bus system. In 32-bit unidirectional mode, this input is not used and should be pulled high. During Reset, used to configure the device as initial IX Bus owner. 1= device is initial owner, 0= device does not own the IX Bus. TK_IN is sampled from the rising edge of RESET_IN#.
Totals:			103	

### 6.3.5 General Purpose I/Os

Table 15. General Purpose I/Os

General Purpose I/O Signal Names	Pin #	Type	Total	Pin Descriptions
GPIO[3:1] [3] [2] [1]	A25 B25 D24	I1/O4	3	Bidirectional General Purpose pins. 64-bit Bidirectional IX Bus mode: Accessible by StrongARM* core. Configurable as Input or Output. 32-bit Unidirectional IX Bus mode: Transmit Port Select [2:0] outputs. GPIO[3] is sampled during reset to determine if a 32-bit or 16-bit BootROM device is used. If low, enable 32-bit BootROM. If high, Enable 16-bit BootROM.
GPIO[0]/ FC_EN0#/ TXPEN	C25	I1/O4	1	Bidirectional General Purpose I/O pin. 1-2 MAC mode (Uni or Bidirectional mode): Active low Flow Control Enable output for MAC 0. 3+ MAC 64-bit Bidirectional IX Bus mode: Accessible to the StrongARM* core. Configurable as input or output. 3+ MAC 32-bit Unidirectional IX Bus mode: Active high Transmit Port Enable for an external PORTCTL#[3:2] decoder.
Totals:			4	

### 6.3.6 Serial Port (UART) Pins

Table 16. Serial Port (UART) Pins

Serial Port (UART) Signal Names	Pin #	Type	Total	Pin Descriptions
RXD	D23	I1	1	UART Receive data.
TXD	C24	O1	1	UART Transmit data.
Totals:			2	

### 6.3.7 PCI Interface Pins

**Table 17. PCI Interface Pins**

PCI Interface Signal Names	Pin #	Type	Total	Pin Descriptions
AD[31:0]	[31] B20 [30] A20 [29] C19 [28] C18 [27] B18 [26] D17 [25] C17 [24] A16 [23] D16 [22] A15 [21] B15 [20] C15 [19] B14 [18] D15 [17] C14 [16] A13 [15] A10 [14] B10 [13] D11 [12] C10 [11] A9 [10] B9 [9] C9 [8] A8 [7] D9 [6] C8 [5] A7 [4] B7 [3] D8 [2] C7 [1] A6 [0] B6	I2/O2/ TS	32	Address/data. These signals are multiplexed address and data bus. The IXP1200 receives addresses as target and drives addresses as master. It receives write data and drives read data as target. It drives write data and receives read data as master.
CBE#[3:0]	[3] B16 [2] B13 [1] C11 [0] B8	I2/O2/ TS	4	Command byte enables. These signals are multiplexed command and byte enable signals. The IXP1200 receives commands as target and drives commands as master. It receives byte enables as target and drives byte enables as master.
PAR	D12	I2/O2/ TS	1	Parity. This signal carries even parity for AD and CBE# pins. It has the same receive and drive characteristics as the address and data bus, except that it occurs on the next PCI clock cycle.
FRAME#	C13	I2/O2/ STS	1	FRAME# indicates the beginning and duration of an access. The IXP1200 receives as target and drives as master.
IRDY#	A12	I2/O2/ STS	1	Initiator ready. Indicates the master's ability to complete the current data phase of the transaction. The IXP1200 receives as target and drives as master.
TRDY#	B12	I2/O2/ STS	1	Target ready. Indicates the target's ability to complete the current data phase of the transaction. The IXP1200 drives as target and receives as master.
STOP#	C12	I2/O2/ STS	1	Stop. Indicates that the target is requesting the master to stop the current transaction. The IXP1200 drives as target and receives as master.

Table 17. PCI Interface Pins (Continued)

PCI Interface Signal Names	Pin #	Type	Total	Pin Descriptions
DEVSEL#	D13	I2/O2/STS	1	Device Select. Indicates that the target has decoded its address as the target of the current access. The IXP1200 drives as target and receives as initiator.
IDSEL	C16	I2	1	Initialization Device Select. Used as Chip Select during PCI Configuration Space read and write transactions.
PERR#	A11	I2/O2/STS	1	Parity error. Used to report data parity errors. The IXP1200 asserts this when it receives bad data parity as target of a write or master of a read.
SERR#	B11	I2/O2/OD	1	System Error. As an input, it can cause an interrupt to the StrongARM* core if the IXP1200 is selected for PCI Central Function and arbitration support (PCI_CFN[1:0]=11). As an output it can be asserted by the IXP1200 by writing the SERR bit in the PCI control register, or in response to a PCI address parity error when not providing PCI Central Function and arbitration support (PCI_CFN[1:0]=00).
PCI_IRQ#	A22	I2/O2/OD	1	PCI Interrupt Request. As output, used to interrupt the PCI Host Processor. It is asserted when there is a doorbell set or there are messages on the I <sub>2</sub> O outbound post list. This is usually connected to INTA# on the PCI Bus. As Input, It is asserted when there is a doorbell set or there are messages on the I <sub>2</sub> O outbound post list.
PCI_RST#	C21	I2/O2/TS	1	PCI Reset. <ul style="list-style-type: none"> <li>When providing PCI Central Function and arbitration support (PCI_CFN[1:0]=11), PCI_RST# is an output controlled by the StrongARM* core. Used to reset the PCI Bus.</li> <li>When not providing PCI Central Function and arbitration (PCI_CFN[1:0]=00), PCI_RST# is an input, and when asserted resets the IXP1200 StrongARM* core, all registers, all transaction queues, and all PCI related state.</li> </ul>
PCI_CLK	D20	I2	1	PCI Clock input. Reference for PCI signals and internal operations. PCI clock is typically 33 to 66 MHz.
PCI_CFN[1:0]	A24 C23	I2	2	PCI Central Function and arbitration select inputs. Sampled on the rising edge of RESET_IN#. When = 11, the IXP1200 provides the PCI Central Function and arbitration support and: <ul style="list-style-type: none"> <li>PCI_RST# is an output asserted by the PCI Unit when initiated by the StrongARM* core.</li> <li>IXP1200 provides bus parking during reset.</li> <li>SERR# is an input that can generate an interrupt to the StrongARM* core.</li> </ul> When = 00, PCI Central Function and arbitration is disabled and: <ul style="list-style-type: none"> <li>PCI_RST# is an input asserted by the Host processor.</li> <li>The IXP1200 does not provide bus parking during reset.</li> </ul> Values of 10 and 01 are reserved for future use.

**Table 17. PCI Interface Pins (Continued)**

PCI Interface Signal Names	Pin #	Type	Total	Pin Descriptions
GNT#[0]	B21	I2/O2	1	<p>PCI Bus Master Grant 1.</p> <p>Internal PCI arbiter is enabled (PCI_CFN[1:0] = 11): Pin is an output to grant a PCI device 1 control of the PCI Bus. (The IXP1200 is PCI device 0 in this case)</p> <p>Internal PCI arbiter is disabled (PCI_CFN[1:0] = 00): Pin is an input that indicates that the IXP1200 can assert FRAME# and become the bus master. If the IXP1200 is idle when GNT#[0] is asserted, it parks the PCI Bus.</p>
REQ#[0]	A21	I2/O2	1	<p>PCI Bus Master Request 1.</p> <p>Internal PCI arbiter is enabled (PCI_CFN[1:0] = 11): Pin is an input indicating an external PCI device is requesting use of the PCI Bus.</p> <p>Internal PCI arbiter is disabled (PCI_CFN[1:0] = 00): Pin is an output indicating that the IXP1200 is requesting use of the PCI Bus.</p>
GNT#[1]	C20	I2/O2	1	<p>PCI Bus Master Grant 2.</p> <p>Internal PCI arbiter is enabled (PCI_CFN[1:0] = 11): Pin is an output to grant a PCI device 2 control of the PCI Bus (The IXP1200 is PCI device 0 in this case).</p> <p>When Internal PCI arbiter is disabled (PCI_CFN[1:0]=00, GNT#[1] should be connected to VDDX through a pullup resistor of 10 KOhms.</p>
REQ#[1]	D19	I2/O2	1	<p>PCI Bus Master Request 2.</p> <p>Internal PCI arbiter is enabled (PCI_CFN[1:0] = 11): This input indicates that PCI device 2 is requesting to take control of the PCI Bus.</p> <p>Is driven to an output high level when internal PCI arbiter is disabled (PCI_CFN[1:0] = 00).</p>
Totals:			54	

## 6.3.8 Power Supply Pins

**Table 18. Power Supply Pins**

Supply Signal Names	Pin #	Type	Total	Pin Descriptions
VDD		P	17	IXP1200 core supply (2V).
	A19, B19, B27, H31, J29, K2, L4, Y4, AA2, AA30, AA31, AC4, AD3, AD28, AE29, AG4, AG28			
Total VDD pins			17	
VDDX		P	40	IXP1200 I/O supply (3.3V).
	A1, A31, B2, B30, C3, C29, D4, D7, D10, D14, D18, D22, D25, D28, G4, G28, K4, K28, P4, P28, V4, V28, AB4, AB28, AE4, AE28, AH4, AH7, AH10, AH14, AH18, AH22, AH25, AH28, AJ3, AJ29, AK2, AK30, AL1, AL31			
Total VDDX pins			40	
VDD_REF	E4	P	1	IXP1200 3.3V reference - used to bias the ESD circuitry Can be tied directly to VDDX external to chip.
VSSP1	A4	P	1	IXP1200 PLL ground.
VDDP1	D5	P	1	IXP1200 2V PLL supply. Use decoupling capacitor between VDDP1 and VSSP1.
Total			3	
VSS		P	48	IXP1200 ground.
	A2, A3, A14, A17, A18, A29, A30, B1, B3, B17, B29, B31, C1, C2, C4, C28, C30, C31, D3, D29, P1, P31, R1, R2, U30, U31, V1, V31, AH3, AH29, AJ1, AJ2, AJ4, AJ28, AJ30, AJ31, AK1, AK3, AK15, AK29, AK31, AL2, AL3, AL14, AL15, AL18, AL29, AL30			
Total VSS pins			48	
Total Power Supply Pins			108	



### 6.3.9 IEEE 1149.1 Interface Pins

Table 19. IEEE 1149.1 Interface Pins

IEEE 1149.1 Interface Pin Name	Pin #	Type	Total	Pin Description
TCK	A23	I1	1	Test Interface reference clock. This clock times all the transfers on the IEEE 1149.1 test interface.
TMS	C22	I1	1	Test Interface mode select. Causes state transitions on the test access port (TAP) controller.
TDI	B22	I1	1	Test Interface data input. The serial input through which IEEE 1149.1 instructions and test data enter the IEEE 1149.1 interface.
TDO	D21	O1	1	Test Interface data output. The serial output through which test instruction and data from the test logic leave the IXP1200.
TRST#	B23	I1	1	Test Interface RESET. When asserted low, the TAP controller is asynchronously forced to enter a reset state, and disables the IEEE 1149.1 port. This pin must be driven or held low to achieve normal device operation.
Totals:			5	

### 6.3.10 Miscellaneous Test Pins

Table 20. Miscellaneous Test Pins

Processor Support Signal Names	Pin #	Type	Total	Pin Descriptions
SCAN_EN	C5	I1	1	Used for Intel test purposes only. Enables internal scan chains for chip testing. This pin should be connected to VSS through a pulldown resistor.
TCK_BYP	D6	I1	1	Used for Intel test purposes only. When high, bypasses PLL for Test/debug. Must be low for normal system operation.
TSTCLK	B5	I1	1	Used for Intel test purposes only. Used as clock input when bypassing the internal PLL clock generator. For Normal operation, this pin should not be allowed to float. It should be pulled up or pulled down through the proper value resistor.
Totals:			3	

### 6.3.11 Pin Usage Summary

Table 21. Pin Usage Summary

Type	Quantity
Inputs	21
Outputs	68
Bidirectional	235
Total Signal	324
Power	108
Overall Totals:	432

## 6.4 Pin/Signal List

Table 22. Pin Table in Pin Order

Pin Number	Signal Name	Pin Number	Signal Name	Pin Number	Signal Name
A1	VDDX	B4	PXTAL	C7	AD[2]
A2	VSS	B5	TSTCLK	C8	AD[6]
A3	VSS	B6	AD[0]	C9	AD[9]
A4	VSSP1	B7	AD[4]	C10	AD[12]
A5	RESET_OUT#	B8	CBE#[0]	C11	CBE#[1]
A6	AD[1]	B9	AD[10]	C12	STOP#
A7	AD[5]	B10	AD[14]	C13	FRAME#
A8	AD[8]	B11	SERR#	C14	AD[17]
A9	AD[11]	B12	TRDY#	C15	AD[20]
A10	AD[15]	B13	CBE#[2]	C16	IDSEL
A11	PERR#	B14	AD[19]	C17	AD[25]
A12	IRDY#	B15	AD[21]	C18	AD[28]
A13	AD[16]	B16	CBE#[3]	C19	AD[29]
A14	VSS	B17	VSS	C20	GNT#[1]
A15	AD[22]	B18	AD[27]	C21	PCI_RST#
A16	AD[24]	B19	VDD	C22	TMS
A17	VSS	B20	AD[31]	C23	PCI_CFN[1]
A18	VSS	B21	GNT#[0]	C24	TXD
A19	VDD	B22	TDI	C25	GPIO[0]/FC_EN0#/ TXPEN
A20	AD[30]	B23	TRST#	C26	CE#[1]
A21	REQ#[0]	B24	SCLKIN	C27	HIGH_EN#/RDY#
A22	PCI_IRQ#	B25	GPIO[2]	C28	VSS
A23	TCK	B26	CE#[2]	C29	VDDX
A24	PCI_CFN[0]	B27	VDD	C30	VSS
A25	GPIO[3]	B28	A[17]	C31	VSS
A26	CE#[3]	B29	VSS	D1	MDATA[1]
A27	CE#[0]	B30	VDDX	D2	MDATA[0]
A28	A[18]	B31	VSS	D3	VSS
A29	VSS	C1	VSS	D4	VDDX
A30	VSS	C2	VSS	D5	VDDP1
A31	VDDX	C3	VDDX	D6	TCK_BYP
B1	VSS	C4	VSS	D7	VDDX
B2	VDDX	C5	SCAN_EN	D8	AD[3]
B3	VSS	C6	RESET_IN#	D9	AD[7]

Table 22. Pin Table in Pin Order (Continued)

Pin Number	Signal Name	Pin Number	Signal Name	Pin Number	Signal Name
D10	VDDX	F31	A[6]	L28	DQ[27]
D11	AD[13]	G1	MDATA[12]	L29	DQ[24]
D12	PAR	G2	MDATA[11]	L30	DQ[22]
D13	DEVSEL#	G3	MDATA[9]	L31	DQ[21]
D14	VDDX	G4	VDDX	M1	MDATA[29]
D15	AD[18]	G28	VDDX	M2	MDATA[28]
D16	AD[23]	G29	A[5]	M3	MDATA[26]
D17	AD[26]	G30	A[3]	M4	MDATA[23]
D18	VDDX	G31	A[2]	M28	DQ[23]
D19	REQ#[1]	H1	MDATA[16]	M29	DQ[20]
D20	PCI_CLK	H2	MDATA[15]	M30	DQ[18]
D21	TDO	H3	MDATA[13]	M31	DQ[17]
D22	VDDX	H4	MDATA[10]	N1	MDATA[32]
D23	RXD	H28	A[4]	N2	MDATA[31]
D24	GPIO[1]	H29	A[1]	N3	MDATA[30]
D25	VDDX	H30	DQ[31]	N4	MDATA[27]
D26	LOW_EN#/DIRW#	H31	VDD	N28	DQ[19]
D27	A[16]	J1	MDATA[19]	N29	DQ[16]
D28	VDDX	J2	MDATA[18]	N30	DQ[15]
D29	VSS	J3	MDATA[17]	N31	DQ[14]
D30	A[14]	J4	MDATA[14]	P1	VSS
D31	A[13]	J28	A[0]	P2	MDATA[34]
E1	MDATA[5]	J29	VDD	P3	MDATA[33]
E2	MDATA[4]	J30	DQ[30]	P4	VDDX
E3	MDATA[2]	J31	DQ[29]	P28	VDDX
E4	VDD_REF	K1	MDATA[21]	P29	DQ[13]
E28	A[15]	K2	VDD	P30	DQ[11]
E29	A[12]	K3	MDATA[20]	P31	VSS
E30	A[10]	K4	VDDX	R1	VSS
E31	A[9]	K28	VDDX	R2	VSS
F1	MDATA[8]	K29	DQ[28]	R3	MDATA[36]
F2	MDATA[7]	K30	DQ[26]	R4	MDATA[35]
F3	MDATA[6]	K31	DQ[25]	R28	DQ[12]
F4	MDATA[3]	L1	MDATA[25]	R29	DQ[10]
F28	A[11]	L2	MDATA[24]	R30	DQ[9]
F29	A[8]	L3	MDATA[22]	R31	DQ[8]
F30	A[7]	L4	VDD	T1	MDATA[37]

**Table 22. Pin Table in Pin Order (Continued)**

Pin Number	Signal Name	Pin Number	Signal Name	Pin Number	Signal Name
T2	MDATA[38]	Y31	SLOW_RD#	AE28	VDDX
T3	MDATA[39]	AA1	MADR[4]	AE29	VDD
T4	MDATA[40]	AA2	VDD	AE30	FDAT[60]
T28	DQ[7]	AA3	MADR[5]	AE31	FDAT[61]
T29	DQ[6]	AA4	MADR[8]	AF1	MDATA[50]
T30	DQ[5]	AA28	PORTCTL#[0]	AF2	MDATA[51]
T31	DQ[4]	AA29	TK_OUT	AF3	MDATA[52]
U1	MDATA[41]	AA30	VDD	AF4	MDATA[55]
U2	MDATA[42]	AA31	VDD	AF28	FDAT[54]
U3	MDATA[43]	AB1	MADR[6]	AF29	FDAT[57]
U4	MDATA[45]	AB2	MADR[7]	AF30	FDAT[58]
U28	DQ[2]	AB3	MADR[9]	AF31	FDAT[59]
U29	DQ[3]	AB4	VDDX	AG1	MDATA[53]
U30	VSS	AB28	VDDX	AG2	MDATA[54]
U31	VSS	AB29	PORTCTL#[1]	AG3	MDATA[56]
V1	VSS	AB30	FCLK	AG4	VDD
V2	MDATA[44]	AB31	TK_IN	AG28	VDD
V4	VDDX	AC1	MADR[10]	AG29	FDAT[53]
V28	VDDX	AC2	MADR[11]	AG30	FDAT[55]
V29	DQ[0]	AC3	MADR[12]	AG31	FDAT[56]
V30	DQ[1]	AC4	VDD	AH1	MDATA[57]
V31	VSS	AC28	FDAT[63]	AH2	MDATA[58]
W1	WE#	AC29	FPS[2]	AH3	VSS
W2	RAS#	AC30	PORTCTL#[3]	AH4	VDDX
W3	CAS#	AC31	PORTCTL#[2]	AH5	MDATA[59]
W4	MADR[2]	AD1	MADR[13]	AH6	MDATA[63]
W28	SLOW_WE#	AD2	SDCLK	AH7	VDDX
W29	SP_CE#	AD3	VDD	AH8	RDYCTL#[1]
W30	SOE#	AD4	MDATA[48]	AH9	RDYBUS[2]
W31	SCLK	AD28	VDD	AH10	VDDX
Y1	MADR[0]	AD29	FDAT[62]	AH11	FAST_RX1
Y2	MADR[1]	AD30	FPS[0]	AH12	SOP/SOP_RX
Y3	MADR[3]	AD31	FPS[1]	AH13	FBE#[3]
Y4	VDD	AE1	MDATA[46]	AH14	VDDX
Y28	CINT#	AE2	MDATA[47]	AH15	FDAT[3]
Y29	SLOW_EN#	AE3	MDATA[49]	AH16	FDAT[8]
Y30	SWE#	AE4	VDDX	AH17	FDAT[13]

Table 22. Pin Table in Pin Order (Continued)

Pin Number	Signal Name	Pin Number	Signal Name	Pin Number	Signal Name
AH18	VDDX	AJ23	FDAT[32]	AK28	FDAT[49]
AH19	FDAT[20]	AJ24	FDAT[36]	AK29	VSS
AH20	FDAT[24]	AJ25	FDAT[40]	AK30	VDDX
AH21	FDAT[28]	AJ26	FDAT[43]	AK31	VSS
AH22	VDDX	AJ27	FDAT[47]	AL1	VDDX
AH23	FDAT[35]	AJ28	VSS	AL2	VSS
AH24	FDAT[39]	AJ29	VDDX	AL3	VSS
AH25	VDDX	AJ30	VSS	AL4	MDATA[61]
AH26	FDAT[46]	AJ31	VSS	AL5	TK_REQ_IN/EOP_TX
AH27	FDAT[50]	AK1	VSS	AL6	RDYCTL#[3]
AH28	VDDX	AK2	VDDX	AL7	RDYBUS[0]
AH29	VSS	AK3	VSS	AL8	RDYBUS[4]
AH30	FDAT[51]	AK4	MDATA[60]	AL9	RDYBUS[7]
AH31	FDAT[52]	AK5	MADR[14]	AL10	TXASIS
AJ1	VSS	AK6	RDYCTL#[4]/FC_EN1# /RXPEN#	AL11	FBE#[1]
AJ2	VSS	AK7	RDYCTL#[0]	AL12	FBE#[5]
AJ3	VDDX	AK8	RDYBUS[3]	AL13	FDAT[0]
AJ4	VSS	AK9	RDYBUS[6]	AL14	VSS
AJ5	MDATA[62]	AK10	RXFAIL	AL15	VSS
AJ6	TK_REQ_OUT/ SOP_TX	AK11	FBE#[0]	AL16	FDAT[5]
AJ7	RDYCTL#[2]	AK12	FBE#[4]	AL17	FDAT[9]
AJ8	RDYBUS[1]	AK13	FBE#[7]	AL18	VSS
AJ9	RDYBUS[5]	AK14	FDAT[2]	AL19	FDAT[15]
AJ10	FAST_RX2	AK15	VSS	AL20	FDAT[18]
AJ11	EOP/EOP_RX	AK16	FDAT[6]	AL21	FDAT[22]
AJ12	FBE#[2]	AK17	FDAT[10]	AL22	FDAT[26]
AJ13	FBE#[6]	AK18	FDAT[12]	AL23	FDAT[30]
AJ14	FDAT[1]	AK19	FDAT[16]	AL24	FDAT[33]
AJ15	FDAT[4]	AK20	FDAT[19]	AL25	FDAT[37]
AJ16	FDAT[7]	AK21	FDAT[23]	AL26	FDAT[41]
AJ17	FDAT[11]	AK22	FDAT[27]	AL27	FDAT[44]
AJ18	FDAT[14]	AK23	FDAT[31]	AL28	FDAT[48]
AJ19	FDAT[17]	AK24	FDAT[34]	AL29	VSS
AJ20	FDAT[21]	AK25	FDAT[38]	AL30	VSS
AJ21	FDAT[25]	AK26	FDAT[42]	AL31	VDDX
AJ22	FDAT[29]	AK27	FDAT[45]		

## 6.5 Signals Listed in Alphabetical Order

**Table 23. Pin Table in Alphabetical Order**

Signal Name	Pin Number	Signal Name	Pin Number	Signal Name	Pin Number
A[0]	J28	AD[22]	A15	DQ[14]	N31
A[1]	H29	AD[23]	D16	DQ[15]	N30
A[10]	E30	AD[24]	A16	DQ[16]	N29
A[11]	F28	AD[25]	C17	DQ[17]	M31
A[12]	E29	AD[26]	D17	DQ[18]	M30
A[13]	D31	AD[27]	B18	DQ[19]	N28
A[14]	D30	AD[28]	C18	DQ[2]	U28
A[15]	E28	AD[29]	C19	DQ[20]	M29
A[16]	D27	AD[3]	D8	DQ[21]	L31
A[17]	B28	AD[30]	A20	DQ[22]	L30
A[18]	A28	AD[31]	B20	DQ[23]	M28
A[2]	G31	AD[4]	B7	DQ[24]	L29
A[3]	G30	AD[5]	A7	DQ[25]	K31
A[4]	H28	AD[6]	C8	DQ[26]	K30
A[5]	G29	AD[7]	D9	DQ[27]	L28
A[6]	F31	AD[8]	A8	DQ[28]	K29
A[7]	F30	AD[9]	C9	DQ[29]	J31
A[8]	F29	CAS#	W3	DQ[3]	U29
A[9]	E31	CBE#[0]	B8	DQ[30]	J30
AD[0]	B6	CBE#[1]	C11	DQ[31]	H30
AD[1]	A6	CBE#[2]	B13	DQ[4]	T31
AD[10]	B9	CBE#[3]	B16	DQ[5]	T30
AD[11]	A9	CE#[0]	A27	DQ[6]	T29
AD[12]	C10	CE#[1]	C26	DQ[7]	T28
AD[13]	D11	CE#[2]	B26	DQ[8]	R31
AD[14]	B10	CE#[3]	A26	DQ[9]	R30
AD[15]	A10	CINT#	Y28	DQM	V3
AD[16]	A13	DEVSEL#	D13	EOP/EOP_RX	AJ11
AD[17]	C14	DQ[0]	V29	FAST_RX1	AH11
AD[18]	D15	DQ[1]	V30	FAST_RX2	AJ10
AD[19]	B14	DQ[10]	R29	FBE#[0]	AK11
AD[2]	C7	DQ[11]	P30	FBE#[1]	AL11
AD[20]	C15	DQ[12]	R28	FBE#[2]	AJ12
AD[21]	B15	DQ[13]	P29	FBE#[3]	AH13

Table 23. Pin Table in Alphabetical Order (Continued)

Signal Name	Pin Number	Signal Name	Pin Number	Signal Name	Pin Number
FBE#[4]	AK12	FDAT[37]	AL25	FRAME#	C13
FBE#[5]	AL12	FDAT[38]	AK25	GNT#[0]	B21
FBE#[6]	AJ13	FDAT[39]	AH24	GNT#[1]	C20
FBE#[7]	AK13	FDAT[4]	AJ15	GPIO[0]/FC_EN0#/ TXPEN	C25
FCLK	AB30	FDAT[40]	AJ25	GPIO[1]	D24
FDAT[0]	AL13	FDAT[41]	AL26	GPIO[2]	B25
FDAT[1]	AJ14	FDAT[42]	AK26	GPIO[3]	A25
FDAT[10]	AK17	FDAT[43]	AJ26	HIGH_EN#/RDY#	C27
FDAT[11]	AJ17	FDAT[44]	AL27	IDSEL	C16
FDAT[12]	AK18	FDAT[45]	AK27	IRDY#	A12
FDAT[13]	AH17	FDAT[46]	AH26	LOW_EN#/DIRW#	D26
FDAT[14]	AJ18	FDAT[47]	AJ27	MADR[0]	Y1
FDAT[15]	AL19	FDAT[48]	AL28	MADR[1]	Y2
FDAT[16]	AK19	FDAT[49]	AK28	MADR[10]	AC1
FDAT[17]	AJ19	FDAT[5]	AL16	MADR[11]	AC2
FDAT[18]	AL20	FDAT[50]	AH27	MADR[12]	AC3
FDAT[19]	AK20	FDAT[51]	AH30	MADR[13]	AD1
FDAT[2]	AK14	FDAT[52]	AH31	MADR[14]	AK5
FDAT[20]	AH19	FDAT[53]	AG29	MADR[2]	W4
FDAT[21]	AJ20	FDAT[54]	AF28	MADR[3]	Y3
FDAT[22]	AL21	FDAT[55]	AG30	MADR[4]	AA1
FDAT[23]	AK21	FDAT[56]	AG31	MADR[5]	AA3
FDAT[24]	AH20	FDAT[57]	AF29	MADR[6]	AB1
FDAT[25]	AJ21	FDAT[58]	AF30	MADR[7]	AB2
FDAT[26]	AL22	FDAT[59]	AF31	MADR[8]	AA4
FDAT[27]	AK22	FDAT[6]	AK16	MADR[9]	AB3
FDAT[28]	AH21	FDAT[60]	AE30	MDATA[0]	D2
FDAT[29]	AJ22	FDAT[61]	AE31	MDATA[1]	D1
FDAT[3]	AH15	FDAT[62]	AD29	MDATA[10]	H4
FDAT[30]	AL23	FDAT[63]	AC28	MDATA[11]	G2
FDAT[31]	AK23	FDAT[7]	AJ16	MDATA[12]	G1
FDAT[32]	AJ23	FDAT[8]	AH16	MDATA[13]	H3
FDAT[33]	AL24	FDAT[9]	AL17	MDATA[14]	J4
FDAT[34]	AK24	FPS[0]	AD30	MDATA[15]	H2
FDAT[35]	AH23	FPS[1]	AD31	MDATA[16]	H1
FDAT[36]	AJ24	FPS[2]	AC29	MDATA[17]	J3



Table 23. Pin Table in Alphabetical Order (Continued)

Signal Name	Pin Number	Signal Name	Pin Number	Signal Name	Pin Number
MDATA[18]	J2	MDATA[50]	AF1	RDYBUS[5]	AJ9
MDATA[19]	J1	MDATA[51]	AF2	RDYBUS[6]	AK9
MDATA[2]	E3	MDATA[52]	AF3	RDYBUS[7]	AL9
MDATA[20]	K3	MDATA[53]	AG1	RDYCTL#[0]	AK7
MDATA[21]	K1	MDATA[54]	AG2	RDYCTL#[1]	AH8
MDATA[22]	L3	MDATA[55]	AF4	RDYCTL#[2]	AJ7
MDATA[23]	M4	MDATA[56]	AG3	RDYCTL#[3]	AL6
MDATA[24]	L2	MDATA[57]	AH1	RDYCTL#[4]/FC_EN1#/ RXPEN#	AK6
MDATA[25]	L1	MDATA[58]	AH2	REQ#[0]	A21
MDATA[26]	M3	MDATA[59]	AH5	REQ#[1]	D19
MDATA[27]	N4	MDATA[6]	F3	RESET_IN#	C6
MDATA[28]	M2	MDATA[60]	AK4	RESET_OUT#	A5
MDATA[29]	M1	MDATA[61]	AL4	RXD	D23
MDATA[3]	F4	MDATA[62]	AJ5	RXFAIL	AK10
MDATA[30]	N3	MDATA[63]	AH6	SCLKIN	B24
MDATA[31]	N2	MDATA[7]	F2	SCAN_EN	C5
MDATA[32]	N1	MDATA[8]	F1	SCLK	W31
MDATA[33]	P3	MDATA[9]	G3	SDCLK	AD2
MDATA[34]	P2	PAR	D12	SERR#	B11
MDATA[35]	R4	PCI_CFN[0]	A24	SLOW_EN#	Y29
MDATA[36]	R3	PCI_CFN[1]	C23	SLOW_RD#	Y31
MDATA[37]	T1	PCI_CLK	D20	SLOW_WE#	W28
MDATA[38]	T2	PCI_IRQ#	A22	SOE#	W30
MDATA[39]	T3	PCI_RST#	C21	SOP/SOP_RX	AH12
MDATA[4]	E2	PERR#	A11	SP_CE#	W29
MDATA[40]	T4	PORTCTL#[0]	AA28	STOP#	C12
MDATA[41]	U1	PORTCTL#[1]	AB29	SWE#	Y30
MDATA[42]	U2	PORTCTL#[2]	AC31	TCK	A23
MDATA[43]	U3	PORTCTL#[3]	AC30	TCK_BYP	D6
MDATA[44]	V2	PXTAL	B4	TDI	B22
MDATA[45]	U4	RAS#	W2	TDO	D21
MDATA[46]	AE1	RDYBUS[0]	AL7	TK_IN	AB31
MDATA[47]	AE2	RDYBUS[1]	AJ8	TK_OUT	AA29
MDATA[48]	AD4	RDYBUS[2]	AH9	TK_REQ_IN/EOP_TX	AL5
MDATA[49]	AE3	RDYBUS[3]	AK8	TK_REQ_OUT/SOP_TX	AJ6
MDATA[5]	E1	RDYBUS[4]	AL8	TMS	C22

Table 23. Pin Table in Alphabetical Order (Continued)

Signal Name	Pin Number	Signal Name	Pin Number	Signal Name	Pin Number
TRDY#	B12	VDDX	D28	VSS	B29
TRST#	B23	VDDX	G4	VSS	B31
TSTCLK	B5	VDDX	G28	VSS	C1
TXASIS	AL10	VDDX	K4	VSS	C2
TXD	C24	VDDX	K28	VSS	C4
VDD	A19	VDDX	P4	VSS	C28
VDD	B19	VDDX	P28	VSS	C30
VDD	B27	VDDX	V4	VSS	C31
VDD	H31	VDDX	V28	VSS	D3
VDD	J29	VDDX	AB4	VSS	D29
VDD	K2	VDDX	AB28	VSS	P1
VDD	L4	VDDX	AE4	VSS	P31
VDD	Y4	VDDX	AE28	VSS	R1
VDD	AA2	VDDX	AH4	VSS	R2
VDD	AA30	VDDX	AH7	VSS	U30
VDD	AA31	VDDX	AH10	VSS	U31
VDD	AC4	VDDX	AH14	VSS	V1
VDD	AD3	VDDX	AH18	VSS	V31
VDD	AD28	VDDX	AH22	VSS	AH3
VDD	AE29	VDDX	AH25	VSS	AH29
VDD	AG4	VDDX	AH28	VSS	AJ1
VDD	AG28	VDDX	AJ3	VSS	AJ2
VDD_REF	E4	VDDX	AJ29	VSS	AJ4
VDDP1	D5	VDDX	AK2	VSS	AJ28
VDDX	A1	VDDX	AK30	VSS	AJ30
VDDX	A31	VDDX	AL1	VSS	AJ31
VDDX	B2	VDDX	AL31	VSS	AK1
VDDX	B30	VSS	A2	VSS	AK3
VDDX	C3	VSS	A3	VSS	AK15
VDDX	C29	VSS	A14	VSS	AK29
VDDX	D4	VSS	A17	VSS	AK31
VDDX	D7	VSS	A18	VSS	AL2
VDDX	D10	VSS	A29	VSS	AL3
VDDX	D14	VSS	A30	VSS	AL14
VDDX	D18	VSS	B1	VSS	AL15
VDDX	D22	VSS	B3	VSS	AL18
VDDX	D25	VSS	B17	VSS	AL29

Table 23. Pin Table in Alphabetical Order (Continued)

Signal Name	Pin Number	Signal Name	Pin Number	Signal Name	Pin Number
VSS	AL30				
VSSP1	A4				
WE#	W1				

## 6.6 IX Bus Pins Function Listed by Operating Mode

Figure 7 through Figure 11 illustrate the four IX Bus modes. Each figure shows the logic interface to one or more MAC devices and is accompanied by a pin description for the IX Bus in that mode.

Figure 7. 64-Bit Bidirectional IX Bus, 1-2 MAC Mode

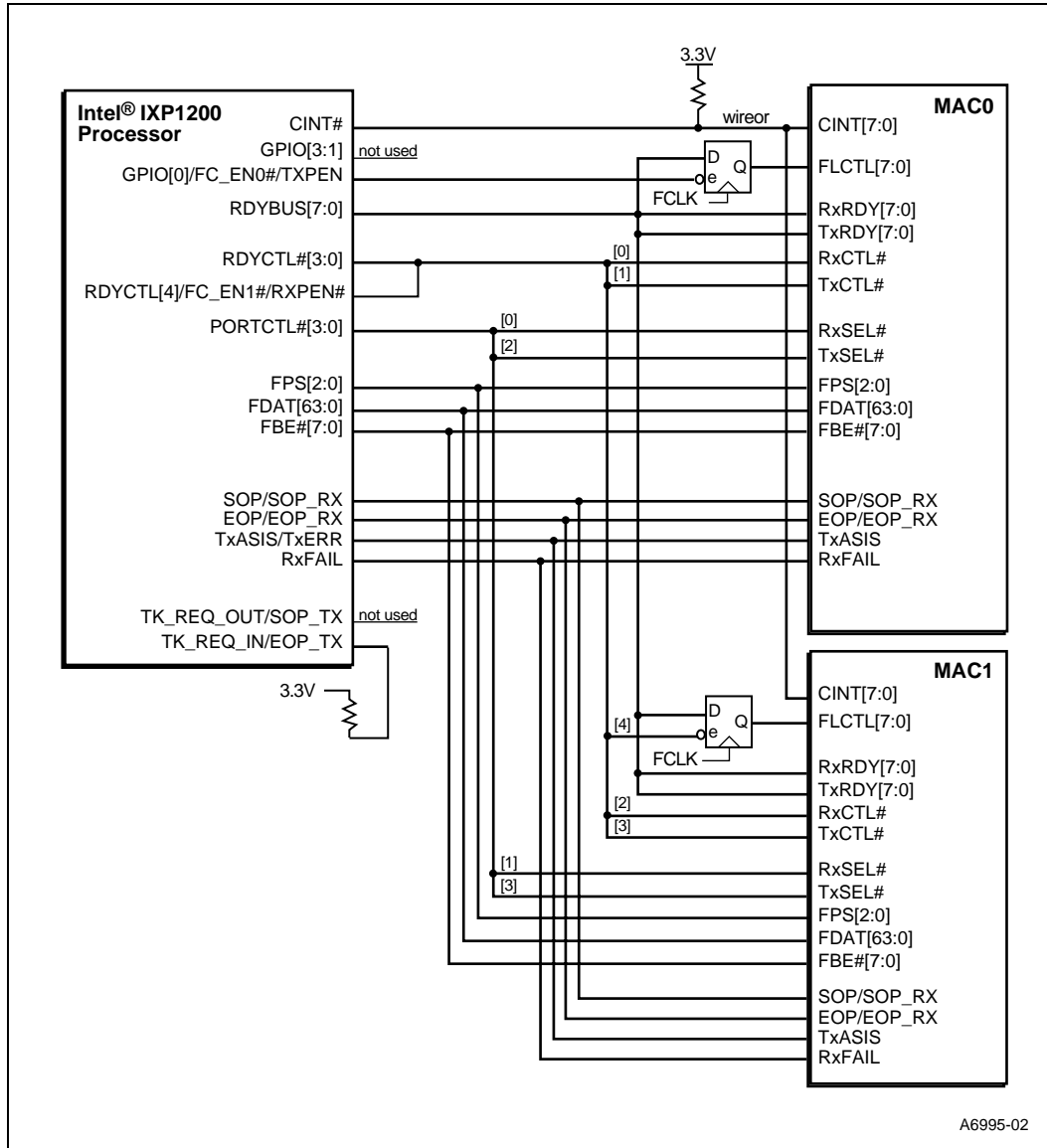

Figure 8. 64-Bit Bidirectional IX Bus, 1-2 MAC Mode, FastPort Device

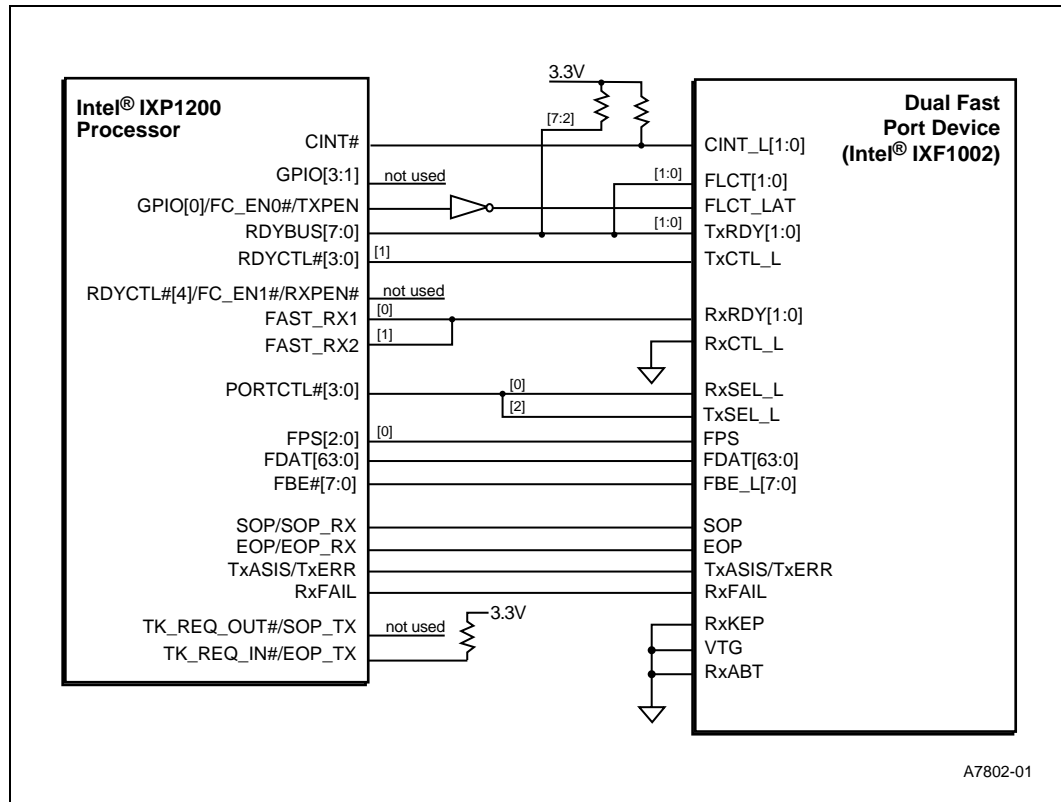
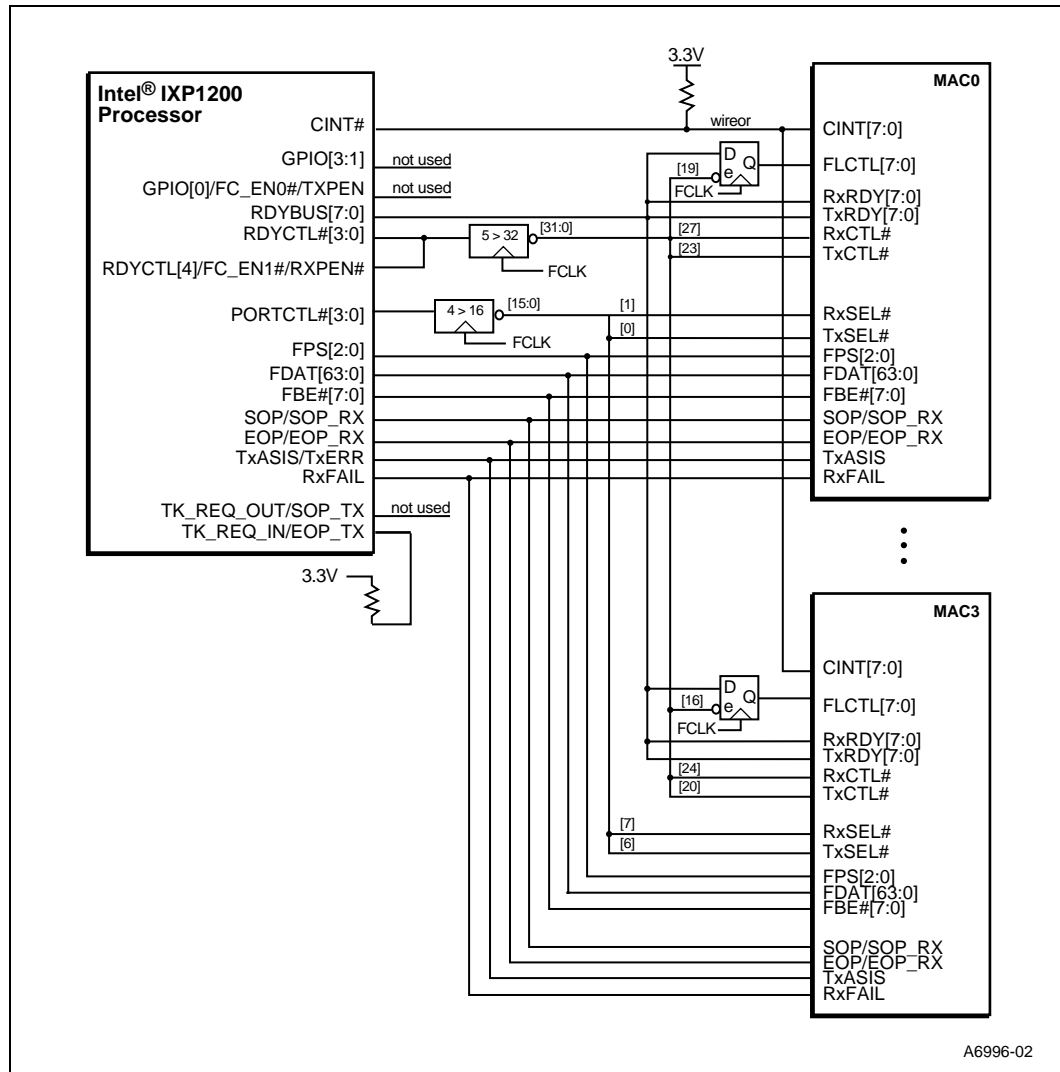

Table 24. 64-Bit Bidirectional IX Bus, 1-2 MAC Mode

Signal	Description
GPIO[3:1]	Active High, input/output assigned to StrongARM* core not used for MAC interface.
GPIO[0]/FC_EN0#/TXPEN	Active Low, output flow-control enable for MAC 0.
RDYCTL#[3:0]	Active Low, output, enables for Transmit or Receive Ready flags.
RDYCTL#[4]/FC_EN1#/RXPEN#	Active Low, output, flow-control enable for MAC 1.
RDYBUS[7:0]	Active High, input/output, Transmit or Receive Ready flags, and flow control mask data.
PORTCTL#[3:0]	Active Low, output, transmit and receive device selects.
FPS[2:0]	Active High, output, port select.
SOP/SOP_RX	Active High, input/output, Start of Packet indication. SOP/SOP_RX is an output during transmit according to values programmed in the TFIFO control field. Is an input during receives indicating Receive Start of Packet from MAC.
TK_REQ_OUT/SOP_TX	Output, not used, no connect.
EOP/EOP_RX	Active High, input/output, End of Packet indication. EOP/EOP_RX is an output during transmit according to values programmed in the TFIFO control field. Is an input during receives indicating Receive End of Packet from MAC.
TK_REQ_IN/EOP_TX	Input/output, not used, terminate through 10 KOhms to VDDX.
TK_IN	Input, not used, must be pulled High in this mode.
TK_OUT	Output, not used, no connect.
RXFAIL	Active High, input/output. Input - Receive Error input. Output - driven low during transmit and when bus maintains a No-Select state.
TXASIS/TXERR	Active High, output. TXASIS/TXERR states are output according to values programmed in the TFIFO Control field. TXASIS state is output coincident with SOP/SOP_RX signal, TXERR state is output coincident with EOP/EOP_RX signal.
FBE#[7:0]	Active Low, byte enables for FDAT [64:0].
FDAT[63:0]	Active High, read and write data.
FAST_RX1	Active High ready input from FastPort 0, pulldown 10 KOhms to GND if not used.
FAST_RX2	Active High ready input from FastPort 1, pulldown 10 KOhms to GND if not used.

Figure 9. 64-Bit Bidirectional IX Bus, 3+ MAC Mode



**Table 25. 64-Bit Bidirectional IX Bus, 3+ MAC Mode  
(Shared IX Bus Operation Only in This Mode)**

Signal	Description
GPIO[3:1]	Active High input/output assigned to StrongARM* core not used for MAC interface.
GPIO[0]/FC_EN0#/ TXPEN	Active High, output assigned to StrongARM* core not used for MAC interface.
RDYCTL#[4:0]	Output, 5 bits encoded for Transmit/Receive ready flags, flow-control, and inter-chip communication in shared IX Bus mode. Shared IX Bus mode, Initial Ready Bus master drives RDYCTL#[4:0] and Ready Bus slave snoops.
RDYBUS[7:0]	Active High, input/output, Transmit or Receive Ready flags, flow control mask data, and inter-processor communication in shared IX Bus mode.
PORTCTL#[3:0]	Active Low, output, 4 bits encoded for transmit and receive commands and device selects. Shared IX Bus mode - Tri-stated when the IXP1200 does not own the IX Bus.
FPS[2:0]	Active High, output, port select. Shared IX Bus mode - Tri-stated when the IXP1200 does not own the IX Bus.
SOP/SOP_RX	Active High, input/output, Start of Packet indication. SOP/SOP_RX is an output during transmit according to values programmed in the TFIFO control field. Is an input during receives indicating Receive Start of Packet from MAC. Shared IX Bus mode - Tri-stated when the IXP1200 does not own the IX Bus.
TK_REQ_OUT/ SOP_TX	Active High, output. Single chip mode - not used, no connect. Shared IX Bus mode - IX Bus Request.
EOP/EOP_RX	Active High, input/output, End of Packet indication. EOP/EOP_RX is an output during transmit according to values programmed in the TFIFO control field. Is an input during receives indicating Receive End of Packet from MAC. Shared IX Bus mode - Tri-stated when the IXP1200 does not own the IX Bus.
TK_REQ_IN/EOP_TX	Active High, input/output. Single chip mode - output, not used, terminate through 10 KOhms to VDDX. Shared IX Bus mode - input, IX Bus Request pending.
TK_IN	Input in Shared IX Bus mode. Single chip mode - pullup through 10 KOhms to VDDX. Shared IX Bus mode - Token_Input, enables IX Bus ownership when a high-to-low transition is detected. At reset, pull down through 10 KOhms to GND to tell the IXP1200 that it does not own the IX Bus, pull up through 10 KOhms to VDDX to set as initial IX Bus owner.
TK_OUT	Active High, output. Single chip mode - output, not used, no connect. Shared IX Bus mode - Token_Output. When high, indicates this IXP1200 owns the IX Bus.
RXFAIL	Active High, input/output. Input - Receive Error input. Output - driven low during transmit and when bus maintains a No-Select state. Shared IX Bus mode - Tri-stated when the IXP1200 does not own the IX Bus.
TXASIS/TXERR	Active High, output. TXASIS/TXERR states are output according to values programmed in the TFIFO Control field. TXASIS state is output coincident with SOP/SOP_RX signal, TXERR state is output coincident with EOP/EOP_RX signal. Shared IX Bus mode - Tri-stated when the IXP1200 does not own the IX Bus.



**Table 25. 64-Bit Bidirectional IX Bus, 3+ MAC Mode  
(Shared IX Bus Operation Only in This Mode) (Continued)**

Signal	Description
FBE#[7:0]	Active Low, byte enables for FDAT [64:0]. Tri-stated in shared IX Bus Mode when the IXP1200 does not own the IX Bus.
FDAT[63:0]	Active High, read and write data. Tri-stated in shared IX Bus mode when the IXP1200 does not own the IX Bus.
FAST_RX1	Active High ready input from FastPort 0, pulldown 10 KOhms to GND if not used.
FAST_RX2	Active High ready input from FastPort 1, pulldown 10 KOhms to GND if not used.
<p><b>Shared IX Bus Operation Signals</b></p> <p>These signals are driven by the IXP1200 IX Bus owner, and are tri-stated when the IXP1200 does not own the IX Bus:</p> <p>PORTCTL#[3:0]            FPS[2:0]            FDAT[63:0]            FBE#[7:0]            TXASIS/TXERR            RXFAIL            SOP/SOP_RX            EOP/EOP_RX</p>	

Figure 10. 32-Bit Unidirectional IX Bus, 1-2 MAC Mode

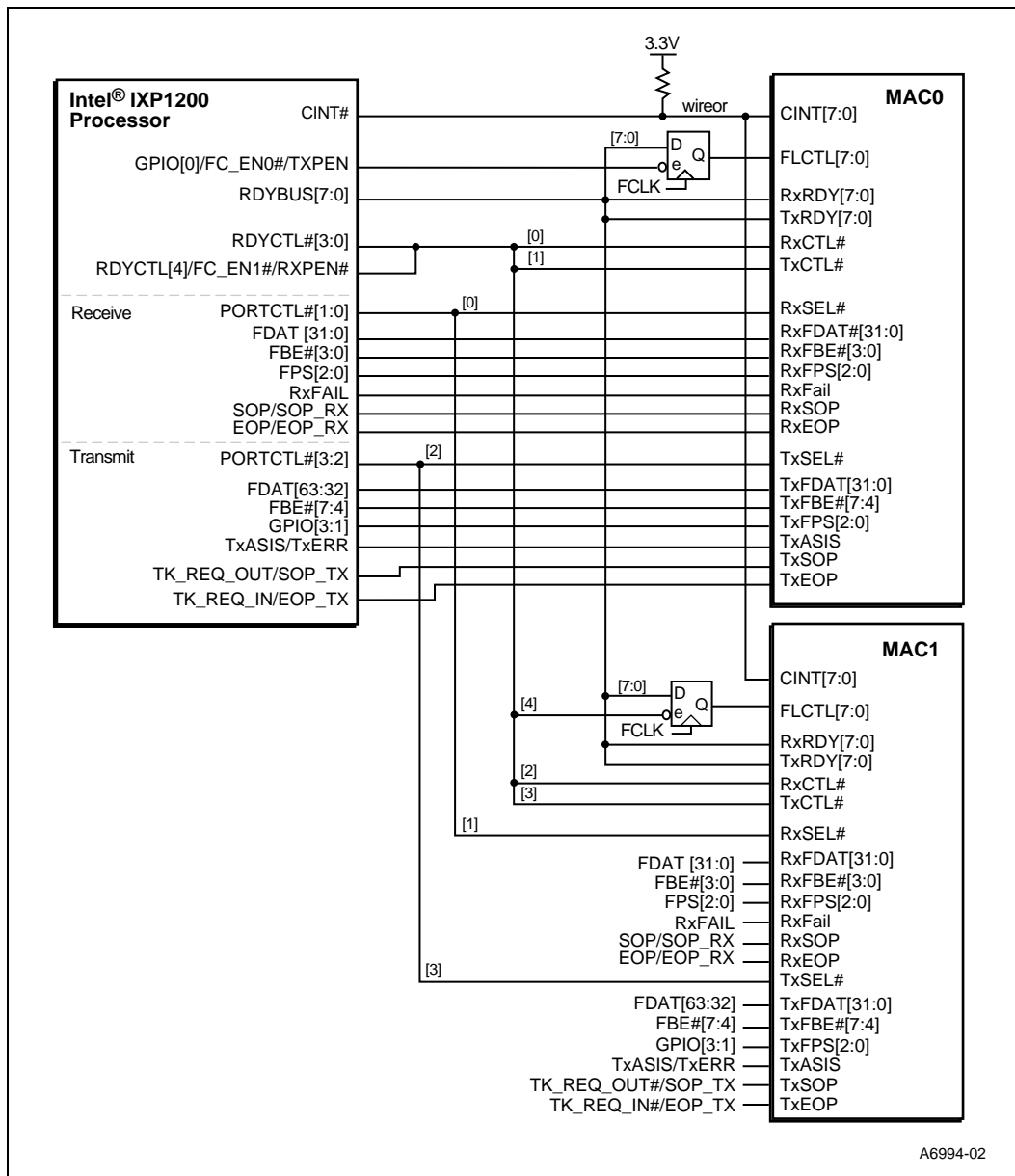

**Table 26. 32-Bit Unidirectional IX Bus, 1-2 MAC Mode**

<b>Transmit Path Signals</b>	<b>Description</b>
GPIO[3:1]	Active high outputs, Transmit Port Select [2:0].
PORTCTL#[3:2]	Active Low, output. Transmit Device Selects [1:0].
TK_REQ_OUT/ SOP_TX	Active High, output, transmit Start of Packet. TK_REQ_OUT/SOP_TX is output during transmit according to value programmed in the TFIFO control field.
TK_REQ_IN/EOP_TX	Active High, output, transmit End of Packet. TK_REQ_IN/EOP_TX is output during transmit according to value programmed in the TFIFO control field.
TXASIS/TXERR	Active High, output. TXASIS/TXERR states are output according to values programmed in the TFIFO Control field. TXASIS state is output coincident with TK_REQ_OUT/SOP_TX signal, TXERR state is output coincident with TK_REQ_IN/EOP_TX signal.
FBE#[7:4]	Active Low, output, byte enables for FDATA [63:31].
FDATA[63:31]	Active High, output, 32-bit transmit data.
<b>Receive Path Signals</b>	
FPS[2:0]	Active High, output. Receive Port Selects [2:0].
PORTCTL#[1:0]	Active Low, output. Receive Device Selects [1:0].
SOP/SOP_RX	Active High, input/output, input receive Start of Packet from the MAC. Driven as output when bus remains in No-Select state.
EOP/EOP_RX	Active High, input/output, input receive End of Packet from the MAC. Driven as output when bus remains in No-Select state.
RXFAIL	Active High, input/output, input Receive Error indication from the MAC. Driven as output when bus remains in No-Select state.
FBE#[3:0]	Active Low, input/output, input byte enables for FDATA [31:0] from the MAC. Driven as output when bus remains in No-Select state.
FDATA[31:0]	Active High, input/output, input 32-bit receive data from the MAC. Driven as output when bus remains in No-Select state.
<b>Control Signals Common to both Transmit/Receive Paths</b>	
GPIO[0]/FC_EN0#/ TXPEN	Active Low, output, flow-control for MAC 0.
RDYCTL#[4]/FC_EN1#/ RXPEN#	Active Low, output, flow-control for MAC 1.
RDYCTL#[3:0]	Active Low enable outputs for Transmit or Receive Ready flags.
RDYBUS[7:0]	Active High, input/output, Transmit or Receive Ready flags, and flow control mask data.
TK_IN	Input, not used, must be pulled High in this mode.
TK_OUT	Output, not used, no connect.
FAST_RX1	Active High, ready input from Fast Port 0, pulldown 10 KOHms if not used.
FAST_RX2	Active High, ready input from Fast Port 1, pulldown 10 KOHms if not used.

Figure 11. 32-bit Unidirectional IX Bus, 3+ MAC Mode (3-4 MACs Supported)

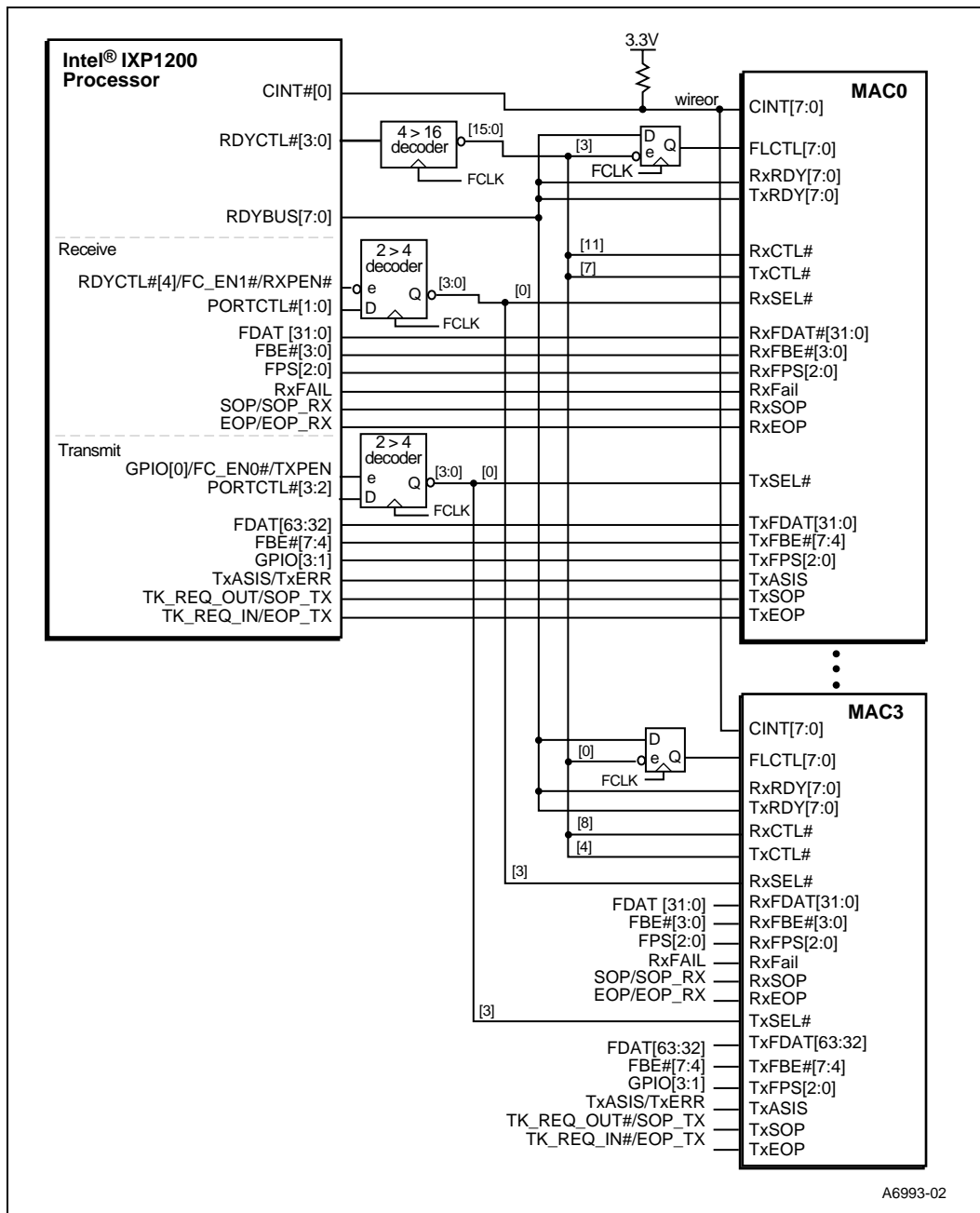

**Table 27. 32-bit Unidirectional IX Bus, 3+ MAC Mode**

Transmit Path Signals	Description
GPIO[3:1]	Active high outputs, Transmit Port Selects [2:0].
PORTCTL#[3:2]	Active Low, outputs. Used with GPIO[0]/FC_EN0#/TXPEN for transmit device select via external 2-to-4 decoder.
GPIO[0]/FC_EN0#/TXPEN	Active High, output, transmit enable. Used with PORTCTL#[3:2] for transmit device select via external 2-to-4 decoder.
TK_REQ_OUT/SOP_TX	Active High, output, transmit Start of Packet. TK_REQ_OUT/SOP_TX is output during transmit according to values programmed in the TFIFO control field.
TK_REQ_IN/EOP_TX	Active High, output, transmit End of Packet. TK_REQ_IN/EOP_TX is output during transmit according to values programmed in the TFIFO control field.
TXASIS/TXERR	Active High, output. TXASIS/TXERR states are output according to values programmed in the TFIFO Control field. TXASIS state is output coincident with TK_REQ_OUT/SOP_TX signal, TXERR state is output coincident with TK_REQ_IN/EOP_TX signal.
FBE#[7:4]	Active Low, output, byte enables for FDATA [63:31].
FDATA[63:31]	Active High, output, 32-bit transmit data.
<b>Receive Path Signals</b>	
FPS[2:0]	Active High, output. Receive Port Selects [2:0].
PORTCTL#[1:0]	Active Low, output. Used with RDYCTL#[4]/FC_EN1#/RXPEN# for receive device select via external 2-to-4 decoder.
RDYCTL#[4]/FC_EN1#/RXPEN#	Active Low, output, receive enable. Used to enable an external 2-to-4 decoder. Used with PORTCTL#[1:0].
SOP/SOP_RX	Active High, input/output, input receive Start of Packet from the MAC. Driven as output when bus remains in No-Select state.
EOP/EOP_RX	Active High, input/output, input receive End of Packet from the MAC. Driven as output when bus remains in No-Select state.
RXFAIL	Active Low, input/output, input Receive Error indication from the MAC. Driven as output when bus remains in No-Select state.
FBE#[3:0]	Active High, input/output, input byte enables for FDATA [31:0] from the MAC. Driven as output when bus remains in No-Select state.
FDATA[31:0]	Active High, input/output, input 32-bit receive data from the MAC. Driven as output when bus remains in No-Select state.
<b>Control Signals Common to both Transmit/Receive Paths</b>	
RDYCTL#[3:0]	Output, 4 bits encoded for Transmit/Receive Ready flags, flow-control, and inter-chip communication. Decode with external 4-to-16 decoder.
RDYBUS[7:0]	Active High, input/output, Transmit or Receive Ready flags, and flow control mask data.
TK_IN	Input, not used, must be pulled High in this mode.
TK_OUT	Output, not used, no connect.
FAST_RX1	Active High, ready input from Fast Port 0, pulldown 10 KOHms if not used.
FAST_RX2	Active High, ready input from Fast Port 1, pulldown 10 KOHms if not used.

## 6.7 IX Bus Decode Table Listed by Operating Mode Type

Table 28. IX Bus Decode Table Listed by Operating Mode Type

PIN NAME	64-bit Bidirectional 1-2 MAC mode	64-bit Bidirectional 3+ MAC mode	32-bit Unidirectional 1-2 MAC mode	32-bit Unidirectional 3+ MAC mode
PORTCTL#[3:0]	1110 MAC0 RxSEL 1101 MAC1 RxSEL 1011 MAC0 TxSEL 0111 MAC1 TxSEL 1111 No Select	0000 MAC0 TxSEL 0001 MAC0 RxSEL 0010 MAC1 TxSEL 0011 MAC1 RxSEL 0100 MAC2 TxSEL 0101 MAC2 RxSEL 0110 MAC3 TxSEL 0111 MAC3 RxSEL 1000 MAC4 TxSEL 1001 MAC4 RxSEL 1010 MAC5 TxSEL 1011 MAC5 RxSEL 1100 MAC6 TxSEL 1101 MAC6 RxSEL 1110/1111 No Select	1110 MAC0 RxSel 1101 MAC1 RxSel 1011 MAC0 TxSel 0111 MAC1 TxSel 1010 MAC0 TxSel/ MAC0 RxSel 0110 MAC1 TxSel/ MAC0 RxSel 1001 MAC0 TxSel/ MAC1 RxSel 0101 MAC1 TxSel/ MAC1 RxSel	If RDYCTL#[4]/ FC_EN1#/ RXPEN# = 0 XX00 MAC0 RxSEL XX01 MAC1 RxSEL XX10 MAC2 RxSEL XX11 MAC3 RxSEL <hr/> If RDYCTL#[4]/ FC_EN1#/ RXPEN# = 1 No Select <hr/> If GPIO[0]/ FC_EN0#/ TXPEN = 1 00XX MAC0 TxSEL 01XX MAC1 TxSEL 10XX MAC2 TxSEL 11XX MAC3 TxSEL <hr/> If GPIO[0]/ FC_EN0#/ TXPEN = 0 No Select
FPS[2:0]	Rx/Tx Port Select	Rx/Tx Port Select	Rx Port Select	Rx Port Select
GPIO[3:1]	Not used	Not used	Tx Port Select	Tx Port Select
GPIO[0]/ FC_EN0#/ TXPEN	MAC0 Flw Ctl enable when low	Not used	MAC0 Flw Ctl enable when low	PORTCTL#[3:2] Tx enable (see above)
FDAT[63:32]	Rx/Tx Data	Rx/Tx Data	Tx Data	Tx Data
FDAT[31:0]	Rx/Tx Data	Rx/Tx Data	Rx Data	Rx Data
FBE#[7:4]	Rx/Tx Byte Enables	Rx/Tx Byte Enables	Tx Byte Enables	Tx Byte Enables
FBE#[3:0]	Rx/Tx Byte Enables	Rx/Tx Byte Enables	Rx Byte Enables	Rx Byte Enables
SOP/SOP_RX	Rx/Tx SOP	Rx/Tx SOP	Rx SOP	Rx SOP
EOP/EOP_RX	Rx/Tx EOP	Rx/Tx EOP	Rx EOP	Rx EOP
TK_REQ_OUT/ SOP_TX	Not used	Not used	Tx SOP	Tx SOP

Table 28. IX Bus Decode Table Listed by Operating Mode Type (Continued)

PIN NAME	64-bit Bidirectional 1-2 MAC mode	64-bit Bidirectional 3+ MAC mode	32-bit Unidirectional 1-2 MAC mode	32-bit Unidirectional 3+ MAC mode
EOP/EOP_TX	Not used	Not used	Tx EOP	Tx EOP
RDYCTL#[4]/ FC_EN1#/ RXPEN#	MAC1 Flw Ctl enable when low	Ready Control (see below)	MAC1 Flw Ctl enable when low	PORTCTL#[1:0] Rx enable (see above)
RDYCTL#[4:0]	x1111 NOP x1110 MAC0 Rx x1101 MAC0 Tx x1011 MAC1 Rx x0111 MAC1 Tx	11111 NOP 11110 GET 1 11100 autopush  11011 MAC0 Rx 11010 MAC1 Rx 11001 MAC2 Rx 11000 MAC3 Rx  10111 MAC0 Tx 10110 MAC1 Tx 10101 MAC2 Tx 10100 MAC3 Tx  10011 MAC0 Flw Ctl enable 10010 MAC1 Flw Ctl enable 10001 MAC2 Flw Ctl enable 10000 MAC3 Flw Ctl enable  01110 GET 2 01101 SEND  01011 MAC4 Rx 01010 MAC5 Rx 01001 MAC6 Rx 00111 MAC4 Tx 00110 MAC5 Tx 00101 MAC6 Tx  00011 MAC4 Flw Ctl enable 00010 MAC5 Flw Ctl enable 00001 MAC6 Flw Ctl enable	x1111 NOP x1110 MAC0 Rx x1101 MAC0 Tx x1011 MAC1 Rx x0111 MAC1 Tx  x1111 NOP x1110 MAC0 Rx x1101 MAC0 Tx x1011 MAC1 Rx x0111 MAC1 Tx	x1111 NOP x1110 GET 1 x1101 SEND x1100 autopush  x1011 MAC0 Rx x1010 MAC1 Rx x1001 MAC2 Rx x1000 MAC3 Rx  x0111 MAC0 Tx x0110 MAC1 Tx x0101 MAC2 Tx x0100 MAC3 Tx  x0011 MAC0 Flw Ctl enable x0010 MAC1 Flw Ctl enable x0001 MAC2 Flw Ctl enable x0000 MAC3 Flw Ctl enable

## 6.8 Pin State During Reset

Table 29 summarizes IXP1200 pin states during reset.

**Table 29. Pin State During Reset**

Function	Pin Name	Pin Reset State	Comment
SRAM	SCLK	output, low	
SRAM	A[17:0]	output, low	
SRAM	DQ[31:0]	output, low	
SRAM	CE#[3:0]	output, high	
SRAM	SLOW_EN#	output, high	
SRAM	SOE#	output, high	
SRAM	SWE#	output, high	
SRAM	HIGH_EN#/RDY#	output, high	
SRAM	LOW_EN#/DIRW#	output, high	
SRAM	SLOW_RD#	output, high	
SRAM	SP_CE#	output, high	
SRAM	SLOW_WE#	output, high	
SRAM	SCLKIN	input	
SDRAM	SDCLK	active clock output	
SDRAM	MADR[14:0]	output, low	
SDRAM	MDATA[63:0]	output, low	
SDRAM	CAS#	output, high	
SDRAM	DQM	output, high	
SDRAM	RAS#	output, high	
SDRAM	WE#	output, high	
PCI	PCI_CLK	input	
PCI	AD[31:0]	PCI_CFN[1:0]=00, AD[31:0]=Hi-Z PCI_CFN[1:0]=11 AD[31:0]=output, low	
PCI	CBE#[3:0]	PCI_CFN[1:0]=00, CBE#[3:0]=Hi-Z PCI_CFN[1:0]=11 CBE#[3:0]=output, low	
PCI	FRAME#	Hi-Z	
PCI	IRDY#	Hi-Z	
PCI	PAR	PCI_CFN[1:0]=00, PAR=Hi-Z PCI_CFN[1:0]=11 PAR=output, low	
PCI	IDSEL	Hi-Z	
PCI	PCI_CFN[0]	input	



**Table 29. Pin State During Reset (Continued)**

Function	Pin Name	Pin Reset State	Comment
PCI	PCI_CFN[1]	input	
PCI	PCI_IRQ#	Hi-Z	
PCI	PCI_RST#	PCI_CFN[1:0]=00, PCI_RST=Hi-Z PCI_CFN[1:0]=11, PCI_RST=output, low	
PCI	PERR#	Hi-Z	
PCI	SERR#	Hi-Z	
PCI	STOP#	Hi-Z	
PCI	DEVSEL#	Hi-Z	
PCI	TRDY#	Hi-Z	
PCI	GNT#[1:0]	PCI_CFN[1:0]=00, GNT#[1:0]=Hi-Z PCI_CFN[1:0]=11, GNT#[1:0]=output, high	
PCI	REQ#[1:0]	Hi-Z	
IX Bus	FCLK	input	
IX Bus	FDAT[63:0]	output, high	
IX Bus	FBE#[7:4]	output, high	
IX Bus	FBE#[3:0]	output, high	
IX Bus	FPS[2:0]	output, high	
IX Bus	TXASIS/TXERR	output, high	
IX Bus	PORTCTL#[3:0]	output, high	
IX Bus	FAST_RX1	input	
IX Bus	FAST_RX2	input	
IX Bus	RDYBUS[7:0]	output, high	
IX Bus	RDYCTL#[3:0]	output, high	
IX Bus	RDYCTL#[4]/FC_EN1#/RXPEN#	output, high	
IX Bus	EOP/EOP_RX	output, high	
IX Bus	SOP/SOP_RX	output, high	
IX Bus	TK_REQ_IN/EOP_TX	output, high	
IX Bus	TK_REQ_OUT/SOP_TX	output, high	
IX Bus	RXFAIL	output, high	
IX Bus	TK_IN	input	drive or pullup high to select initial owner
IX Bus	TK_OUT	Hi-Z	
IX Bus	GPIO[3]	input	
IX Bus	GPIO[2]	input	
IX Bus	GPIO[1]	input	
IX Bus	GPIO[0]/FC_EN0#/TXPEN	input	

Table 29. Pin State During Reset (Continued)

Function	Pin Name	Pin Reset State	Comment
Misc Test	TCK_BYP	input	
Misc Test	TSTCLK	input	
Misc Test	SCAN_EN	input	
Processor Support	PXTAL	input	
Processor Support	CINT#	input	
Processor Support	RESET_IN#	input	
Processor Support	RESET_OUT#	output, low	
Serial	RXD	input	
Serial	TXD	output, high	
IEEE 1149.1	TCK	input	
IEEE 1149.1	TDI	input	
IEEE 1149.1	TDO	output, undefined	
IEEE 1149.1	TMS	input	
IEEE 1149.1	TRST#	input	

## 6.9 Pullup/Pulldown and Unused Pin Guidelines

For normal (i.e., non-test mode) operation, terminate signals as follows:

- Pullup these signals to VDDX: TMS, TDI.
- TCK may be pulled up to VDDX or pulled down to VSSX at the system designer's option.
- Pulldown these signals to VSS: SCAN\_EN, TCK\_BYP, TRST#.
- Pullup this signal to VDDX or pulldown to VSS; do not allow it to float: TSTCLK.
- GPIO[3:1] and GPIO[0]/FC\_EN0#/TXPEN are tri-stated during reset. If these signals are used to drive external logic, pullup or pulldown as appropriate to ensure valid logic levels during reset.

Terminate unused signals as follows:

- Pullup these signals to VDDX: GNT#[1], TK\_IN, TK\_REQ\_IN/EOP\_TX.
- Pulldown these signals to VSS: SCLKIN, FAST\_RX1, FAST\_RX2.

For shared IX Bus operation, it is recommended to pullup PORTCTL#[3:0] and, additionally, FPS[2:0] and TXASIS/TXERR at the designer's discretion.

Typical pullup/pulldown resistor values are in the range of 5-10 KOhms.

## 7.0 Electrical Specifications

This chapter specifies the following electrical behavior of the IXP1200:

- Absolute maximum ratings.
- DC specifications.
- AC timing specifications for the following signal interfaces:
  - PXTAL Clock input.
  - PCI Bus Interface.
  - IX Bus Interface.
  - Ready Bus Interface.
  - TK\_OUT/TK\_IN signals.
  - SRAM interface.
  - SDRAM Interface.
  - Reset signals.
  - GPIO signals.
  - IEEE 1149.1 Interface.
  - Serial Port signals.

### 7.1 Absolute Maximum Ratings

The IXP1200 is specified to operate at a maximum core frequency ( $F_{\text{core}}$ ) of 232 MHz at a junction temperature ( $T_j$ ) not to exceed 100°C. Table 30 lists the absolute maximum ratings for the IXP1200. These are stress ratings only; stressing the device beyond the absolute maximum ratings may cause permanent damage. Operating beyond the functional operating range (Table 30) is not recommended and extended exposure beyond the functional operating range may affect reliability.

Under all operating conditions, the 3.3 V to 2.0 V supply voltage difference ( $V_{\text{delta}}$ ) must not be exceeded or permanent damage to the device may result.

**Table 30. Absolute Maximum Ratings**

Parameter	Minimum	Maximum	Comment
Junction temperature, $T_j$	---	100°C	
Maximum voltage applied to signal pins		3.6 V	
Supply voltage (core and PLL), VDD, VDDP1	1.9 V	2.1 V	2 V supply
Supply voltage (I/O), VDDX, VDDREF	3.0 V	3.6 V	3.3 V supply
Storage temperature range	-55°C	125°C	
$V_{\text{delta}}$	0.0 V	1.8 V	(VDDX - VDD) or (VDDX - VDDP1)

The power specifications listed below are based on the following assumption:

- PCI Bus Frequency (PCI\_CLK) = 66 MHz.

**Table 31. Functional Operating Range**

Parameter	Minimum	Maximum	Comment
Operating temperature range	0°C	70°C	Tjmax to be managed to stay below 100°C. (see the Heatsink application in Figure 12).
Supply voltage (core and PLL), VDD, VDDP1	1.9 V	2.1 V	2.0 V +/- 5%
Supply voltage (I/O), VDDX, VDDREF	3.0 V	3.6 V	3.3 V +/- 10%

**Table 32. Typical and Maximum Power**

Parameter	Core Freq/IX Bus Freq 166 MHz/66 MHz		Core Freq/IX Bus Freq 200 MHz/85 MHz		Core Freq/IX Bus Freq 232 MHz/104 MHz	
	Typical <sup>1,2</sup>	Maximum <sup>1</sup>	Typical <sup>1,2</sup>	Maximum <sup>1</sup>	Typical <sup>1,2</sup>	Maximum <sup>1</sup>
2.0 V supply	3.3 W	4.8 W	3.9 W	5.4 W	4.5 W	5.9 W
3.3 V supply	0.5 W	1.2 W	0.58 W	1.2 W	0.69 W	0.8 W
Total Power	3.80 W	6.0 W	4.48 W	6.6 W	5.19 W	6.7 W

1. Typical and maximum power specifications are based upon the bus loading shown in Table 33.
2. Typical power measured at nominal supply voltages.

**Table 33. Maximum and Typical Bus Loading Used for the Power Calculations<sup>1</sup>**

	Maximum Power Load for Core Freq/IX Bus Freq 166 MHz/66 MHz	Maximum Power Load for Core Freq/IX Bus Freq 200 MHz/85 MHz	Maximum Power Load for Core Freq/IX Bus Freq 232 MHz/104 MHz	Typical Power Load for IX Bus Frequency ≤ 85 MHz
SDRAM Bus	8	8	5	5
SRAM Bus	8	8	5	5
IX Bus	7	4	1	2

1. A load is defined as input capacitance equivalent to a CMOS gate + minimal trace length capacitance, typically 8 pF. The customer is responsible for managing the signal integrity and external power issues that occur with increased IXP1200 Bus loading in their application to ensure reliable system operation.

Figure 12. Typical IXP1200 Heatsink Application

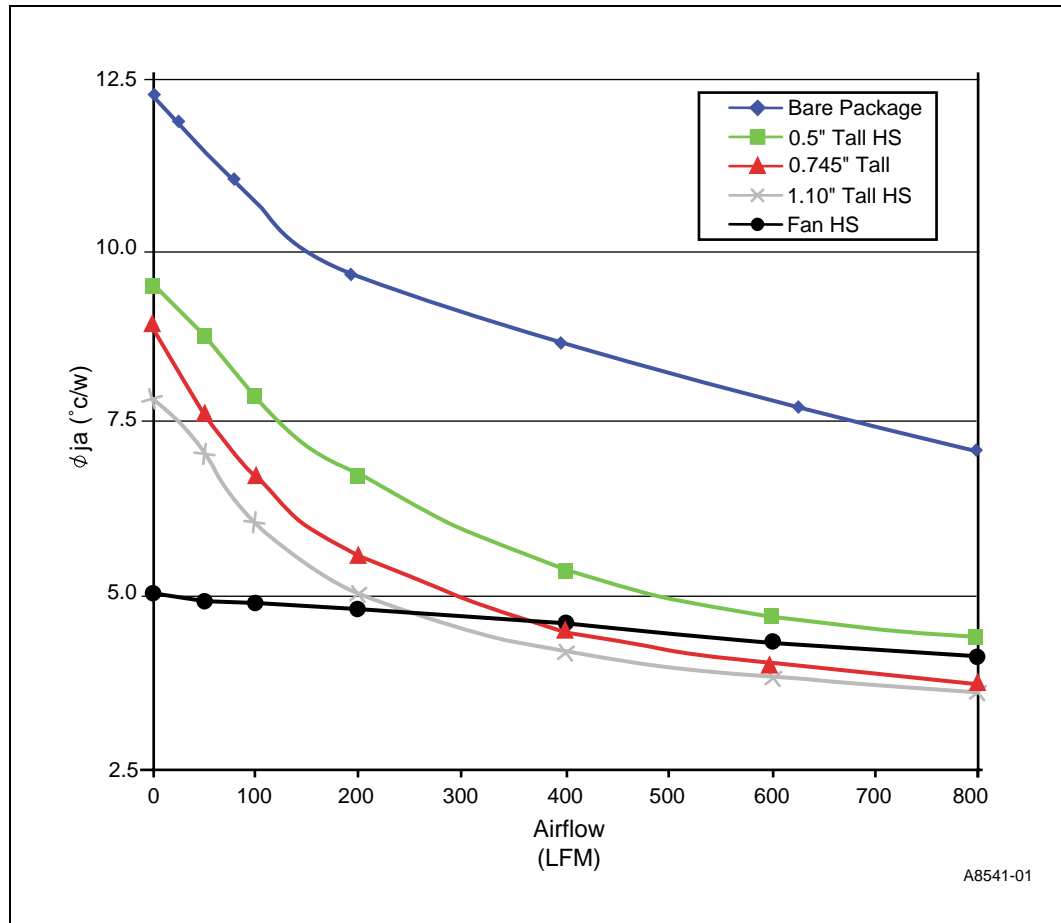

**Note:** The heat sink comparison shown in Figure 12 was tested on an IXP1200 Network Processor package mounted on a 4 inch-by-4 inch test board.

**Note:** Refer to the *IXP1200 Network Processor Family Heatsinks:  $\theta_{ja}$  and Airflow - Application Note* for additional information on heatsinks and thermal management.

## 7.2 DC Specifications

The IXP1200 supports two fundamental I/O buffer Types: Type 1 and Type 2. The Pin Description section defines which pins use which I/O buffer type. The driver characteristics are described in the following sections. Please note that IXP1200 input pins are not 5 V tolerant. Devices driving the IXP1200 must provide 3.3 V signal levels or use level shifting buffers to provide 3.3 V compatible levels, otherwise damage to the device will result.

The Type 1 pins are 3.3 V Low Voltage TTL compatible I/O buffers. There are three versions of the Type 1 driver that differ by the maximum available driver current.

The Type 2 pins are 3.3 V I/O buffers (supporting *PCI Local Bus Specification, Revision 2.2*).

### 7.2.1 Type 1 Driver DC Specifications

Table 34 refers to pin types: I1, O1, O3, O4, O5.

**Table 34. I1, I3, O1, O3, O4, and O5 Pin Types**

Symbol	Parameter	Condition	Minimum	Maximum
$V_{ih}$	Input High Voltage		2.0 V	---
$V_{il}$	Input Low Voltage		---	0.8 V
$V_{oh}$	Output High Voltage	O1: I <sub>oh</sub> = -2 mA O3: I <sub>oh</sub> = -8 mA O4: I <sub>oh</sub> = -4 mA O5: I <sub>oh</sub> = -4 mA	2.4 V	-
$V_{ol}$	Output Low Voltage	O1: I <sub>ol</sub> = 2 mA O3: I <sub>ol</sub> = 8 mA O4: I <sub>ol</sub> = 4 mA O5: I <sub>ol</sub> = 4 mA	---	0.4 V
$I_i$	Input Leakage Current <sup>1</sup>	$0 \leq V_{in} \leq V_{DDX}$	-10 $\mu$ A	10 $\mu$ A
$C_{in}$	Pin Capacitance	-	4 pF	10 pF

1. Input leakage currents include high impedance output leakage for all bidirectional buffers with tri-state outputs.

## 7.2.2 Type 2 Driver DC Specifications

Table 35 refers to pin types: I2, O2.

**Table 35. I2 and O2 Pin Types**

Symbol	Parameter	Condition	Minimum	Maximum
$V_{ih}$	Input High Voltage		$0.5 \times VDDX$	$VDD\_REF + 0.5 \text{ V}$
$V_{il}$	Input Low Voltage		---	$0.3 \times VDDX$
$V_{oh}$	Output High Voltage	$I_{oh} = -500 \text{ uA}$	$0.9 \times VDDX$	---
$V_{ol}$	Output Low Voltage	$I_{ol} = 1500 \text{ uA}$	---	$0.1 \times VDDX$
$I_i$	Input Leakage Current <sup>1</sup>	$0 \leq V_{in} \leq VDDX$	$-10 \text{ }\mu\text{A}$	$10 \text{ }\mu\text{A}$
$C_{in}$	Pin Capacitance		$5 \text{ pF}$	$10 \text{ pF}$

1. Input leakage currents include high impedance output leakage for all bidirectional buffers with tri-state outputs.

**Note:** In Table 34 and Table 35, currents into the chip (chip sinking) are denoted as positive(+) current. Currents from the chip (chip sourcing) are denoted as negative(-) current. Input leakage currents include high-Z output leakage for all bidirectional buffers with tri-state outputs. The electrical specifications are preliminary and subject to change.

## 7.2.3 Overshoot/Undershoot Specifications

The IXP1200 has been designed to be tolerant of overshoot and undershoot associated with normal I/O switching. However, excessive overshoot or undershoot of I/O signals can cause the device to latchup. Table 36 specifies limits on I/O overshoot and undershoot that should never be exceeded.

**Table 36. Overshoot/Undershoot Specifications**

Pin Type	Undershoot	Overshoot	Maximum Duration
I1/O1	$-0.75 \text{ V}$	$VDDX + 0.7 \text{ V}$	$4 \text{ ns}$
I2/O2	$-0.7 \text{ V}$	$VDDX + 0.65 \text{ V}$	$4 \text{ ns}$
O3	$-0.7 \text{ V}$	$VDDX + 0.6 \text{ V}$	$4 \text{ ns}$
O4	$-0.75 \text{ V}$	$VDDX + 1.0 \text{ V}$	$4 \text{ ns}$
O5	$-0.7 \text{ V}$	$VDDX + 0.65 \text{ V}$	$4 \text{ ns}$

## 7.3 AC Specifications

### 7.3.1 Clock Timing Specifications

The ac specifications consist of input requirements and output responses. The input requirements consist of setup and hold times, pulse widths, and high and low times. Output responses are delays from clock to signal. The ac specifications are defined separately for each clock domain within the IXP1200.

For example, Figure 14 shows the ac parameter measurements for the PCI\_CLK signal, and Table 38 and Table 39 specify parameter values for clock signal ac timing. See also Figure 15 for a further illustration of signal timing. Unless otherwise noted, all ac parameters are guaranteed when tested within the functional operating range of Table 31.

Unless otherwise indicated, all ac output delays are measured with a 5 pF load. Capacitive deratings are provided for all output buffers.

### 7.3.2 PXTAL Clock Input

Figure 13. PXTAL Clock Input

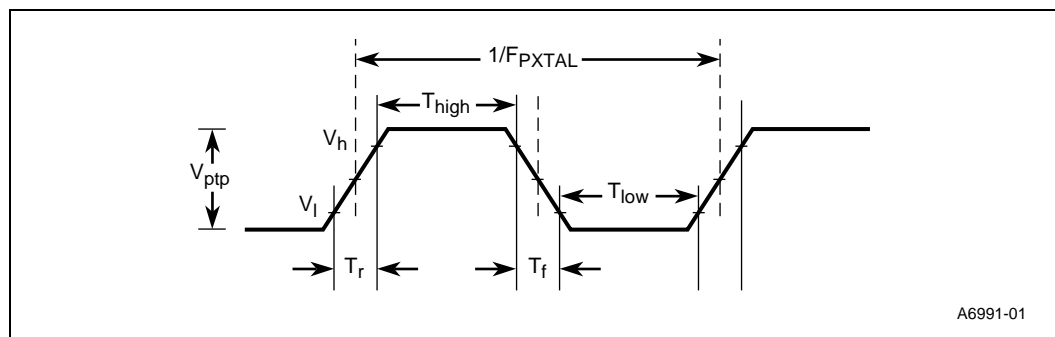

Table 37. PXTAL Clock Inputs

Symbol	Parameter	Minimum	Typical	Maximum	Unit
$F_{pxtal}$	Clock frequency	3.5795	3.6864	3.7878	MHz
$V_{ptp}$	Clock peak to peak	$0.6 \cdot V_{DDX}$		---	V
$V_{high}$	Clock high threshold	2.0		---	V
$V_{low}$	Clock low threshold	---		0.8	V
	Clock slew rate <sup>1</sup>	1		4	V/ns
$F_{core}$	Core frequency <sup>2,3,4</sup>		165.89		MHz

1. Not tested. Guaranteed by design.

2. Core frequency ( $F_{core}$ ) of 165.89 MHz when register PLL\_CFG[4:0] = 10000b.

3. Core frequency ( $F_{core}$ ) of 166.67 MHz when register PLL\_CFG[4:0] = 01111b and  $F_{pxtal}$  = 3.7878 MHz. Refer to the *IXP1200 Network Processor Family Microcode Programmer's Reference Manual* for a complete list of programmable frequencies.

4. Core frequency ( $F_{core}$ ) of 199.0656 MHz when register PLL\_CFG[4:0] = 10011b and  $F_{pxtal}$  = 3.6864 MHz. Refer to the *IXP1200 Network Processor Family Microcode Programmer's Reference Manual* for a complete list of programmable frequencies.



### 7.3.3 PXTAL Clock Oscillator Specifications

Frequency:	$F_{\text{pxtal}} \pm 0.01\%$
Stability:	100 ppm
Voltage signal level:	3.3 Volts
Rise/fall time:	< 4 ns
Duty cycle:	40%-60%

### 7.3.4 PCI

#### 7.3.4.1 PCI Electrical Specification Conformance

The IXP1200 PCI pins support the basic set of PCI electrical specifications in the *PCI Local Bus Specification, Revision 2.2*. See that document for a complete description of the PCI I/O protocol and pin ac specifications.

#### 7.3.4.2 PCI Clock Signal AC Parameter Measurements

Figure 14. PCI Clock Signal AC Parameter Measurements

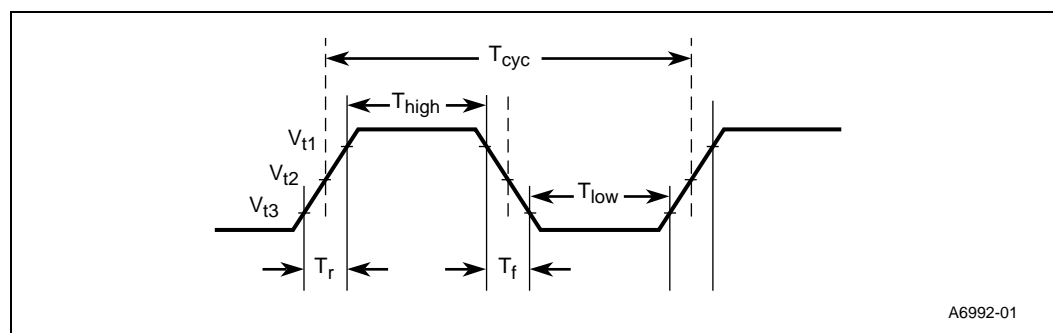

$V_{t1} = 0.5 * V_{DDX}$   
 $V_{t2} = 0.4 * V_{DDX}$   
 $V_{t3} = 0.3 * V_{DDX}$

Table 38. 66 MHz PCI Clock Signal AC Parameters

Symbol	Parameter	Minimum	Maximum	Unit
$T_{\text{cyc}}$	PCI_CLK cycle time	15	$\infty$	ns
$T_{\text{high}}$	PCI_CLK high time	6	---	ns
$T_{\text{low}}$	PCI_CLK low time	6	---	ns
	PCI_CLK slew rate <sup>1, 2</sup>	1.5	4	V/ns
	$F_{\text{core}}$ /PCI Clock Ratio	2:1		

- 0.2 VDDX to 0.6 VDDX.
- Not tested. Guaranteed by design.

**Table 39. 33 MHz PCI Clock Signal AC Parameters**

Symbol	Parameter	Minimum	Maximum	Unit
$T_{cyc}$	PCI_CLK cycle time	30	$\infty$	ns
$T_{high}$	PCI_CLK high time	11	---	ns
$T_{low}$	PCI_CLK low time	11	---	ns
	PCI_CLK slew rate <sup>1 2</sup>	1	4	V/ns
	$F_{core}$ /PCI Clock Ratio	2:1		

1. 0.2 VDDX to 0.6 VDDX.
2. Not tested. Guaranteed by design.

**Figure 15. PCI Bus Signals**

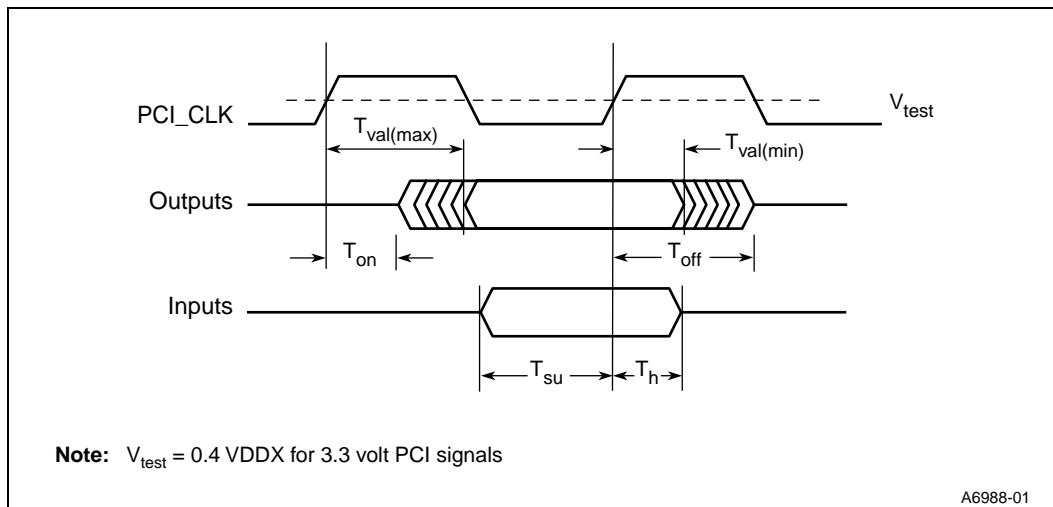

### 7.3.4.3 PCI Bus Signals Timing

**Table 40. 33 MHz PCI Signal Timing**

Symbol	Parameter	Minimum	Maximum	Unit
$T_{val}^1$	CLK to signal valid delay, bused signals	1.5	11	ns
$T_{val}^1$ (point-to-point)	CLK to signal valid delay, point-to-point signals <sup>2</sup>	1.5	12	ns
$T_{on}^3$	Float to active delay	2	---	
$T_{off}^3$	Active to float delay	---	28	ns
$T_{su}$	Input setup time to CLK, bused signals <sup>2</sup>	7	---	ns
$T_{su}$ (point-to-point)	Input setup time to CLK, point-to-point signals <sup>4</sup>	10	---	ns
$T_h^1$	Input signal hold time from CLK	1	---	ns

1. These parameters are at variance with those in the *PCI Local Bus Specification, Revision 2.2*.
2. Point-to-point signals are REQ#, GNT#.
3. Not tested. Guaranteed by design.
4. Bused signals are AD, CBE#, PAR, PERR#, SERR#, FRAME#, IRDY#, TRDY#, DEVSEL#, STOP#.

**Table 41. 66 MHz PCI Signal Timing**

Symbol	Parameter	Minimum	Maximum	Unit
$T_{val}^1$	CLK to signal valid delay, bused signals	1.5	7	ns
$T_{val}^1$ (point-to-point)	CLK to signal valid delay, point-to-point signals <sup>2</sup>	1.5	7	ns
$T_{on}^3$	Float to active delay	2	---	
$T_{off}^3$	Active to float delay	---	6	ns
$T_{su}$	Input setup time to CLK, bused signals <sup>4</sup>	3	---	ns
$T_{su}$ (point-to-point)	Input setup time to CLK, point-to-point signals <sup>2</sup>	5	---	ns
$T_h^1$	Input signal hold time from CLK	1	---	ns

1. These parameters are at variance with those in the *PCI Local Bus Specification, Revision 2.2*.
2. Point-to-point signals are REQ#, GNT#.
3. Not tested. Guaranteed by design.
4. Bused signals are AD, CBE#, PAR, PERR#, SERR#, FRAME#, IRDY#, TRDY#, DEVSEL#, STOP#.

### 7.3.5 Reset

#### 7.3.5.1 Reset Timings Specification

Table 42 shows the reset timing specifications for RESET\_IN# and RESET\_OUT#.

**Table 42. Reset Timings Specification**

Symbol	Parameter	Minimum	Maximum	Unit
$t_{RST}$	RESET_IN# asserted after power stable.	150	--	ms
$t_{SG}$	GPIO[3] setup to reset sample edge.	2		core_clk cycles <sup>1</sup>
$t_{HG}$	GPIO[3] hold from reset sample edge.	9		core_clk cycles <sup>1</sup>
$t_{OETK}$	TK_OUT hi-z to valid output.	4	7	core_clk cycles <sup>1</sup>

1. core\_clk is nominally running at 29.491 MHz after a hard reset when PXTAL is 3.6864 MHz.

**Figure 16. RESET\_IN# Timing Diagram**

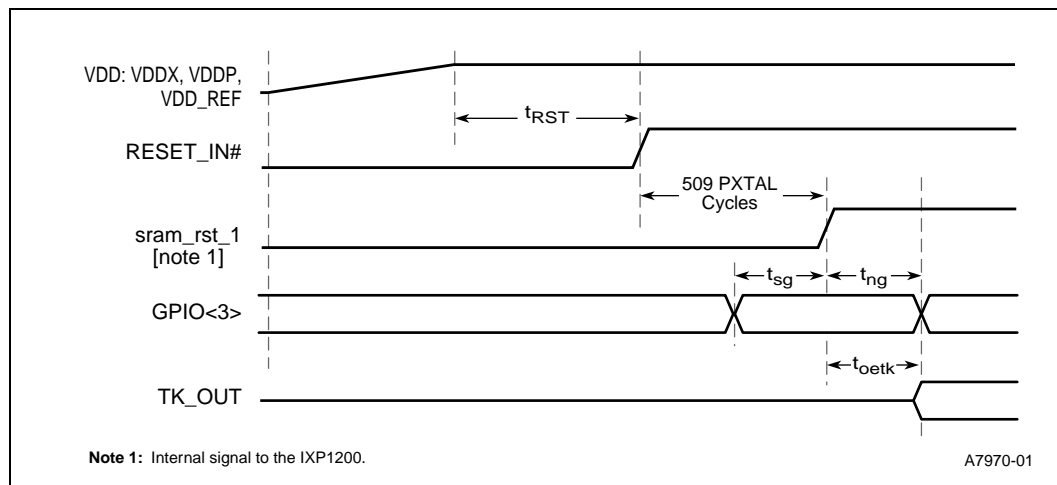

### 7.3.6 IEEE 1149.1

The following pins are considered IEEE 1149.1 compliance pins:

RESET\_IN#  
PCI\_CLK  
SCAN\_EN  
TCK\_BYP  
TSTCLK

The following pins are not connected to the Boundary Scan ring:

RESET\_IN#  
PCI\_CLK  
SCAN\_EN  
TCK\_BYP  
TSTCLK  
TCK  
TMS  
TDI  
TDO  
TRST#

**Caution:** A clock signal must be applied to the core of the IXP1200 when using IEEE 1149.1 functions. The PXTAL clock input should be active, or, if using bypass mode, (TCK\_BYP = 1) TSTCLK should be active. Failure to observe this rule may cause device damage.

7.3.6.1 IEEE 1149.1 Timing Specifications

Figure 17. IEEE 1149.1/Boundary-Scan General Timing

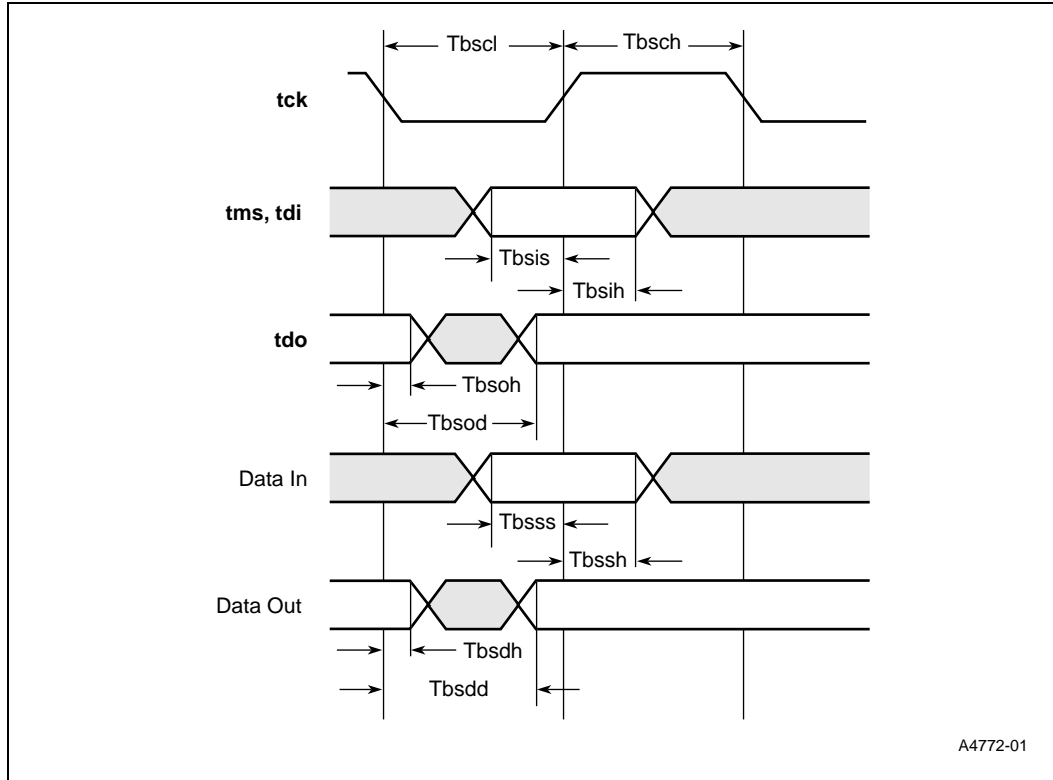

**Figure 18. IEEE 1149.1/Boundary-Scan Tri-State Timing**

Table 43 shows the IEEE 1149.1/boundary-scan interface timing specifications.

**Table 43. IEEE 1149.1/Boundary-Scan Interface Timing**

Symbol	Parameter	Minimum	Typical	Maximum	Units	Notes
Freq	TCK frequency		10		MHz	
$T_{bscl}$	TCK low period	–	50	–	ns	1
$T_{bsch}$	TCK high period	–	50	–	ns	1
$T_{bsis}$	TDI, TMS setup time	40	–	–	ns	–
$T_{bsih}$	TDI, TMS hold time	40	–	–	ns	–
$T_{bsod}$	TDO valid delay	20	–	30	ns	–
$T_{bsss}$	I/O signal setup time	40	–	–	ns	–
$T_{bssh}$	I/O signal hold time	40	–	–	ns	–
$T_{bsd}$	Data output valid	20	–	30	ns	–
$T_{bsoe}^1, T_{bsoz}^1$	TDO float delay	5	–	40	ns	–
$T_{bsde}^1, T_{bsdz}^1$	Data output float delay	5	–	40	ns	–
$T_{bsr}$	Reset period	40	–	–	ns	–

**NOTES:**  
 1. TCK may be stopped indefinitely in either the low or high phase.

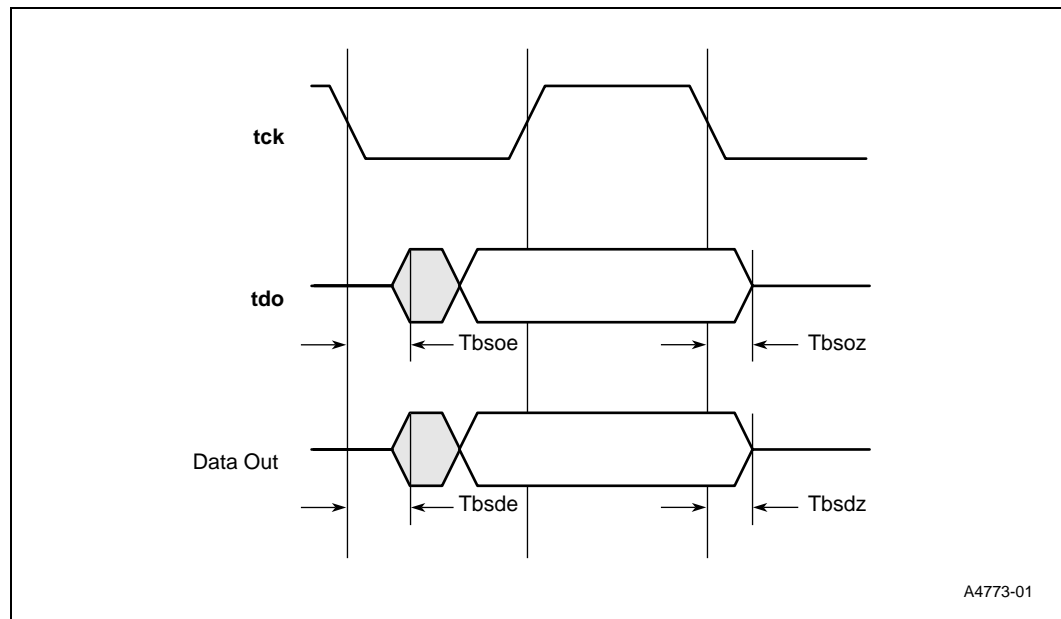
1. Not tested. Guaranteed by design.

## 7.3.7 IX Bus

### 7.3.7.1 FCLK Signal AC Parameter Measurements

Figure 19. FCLK Signal AC Parameter Measurements

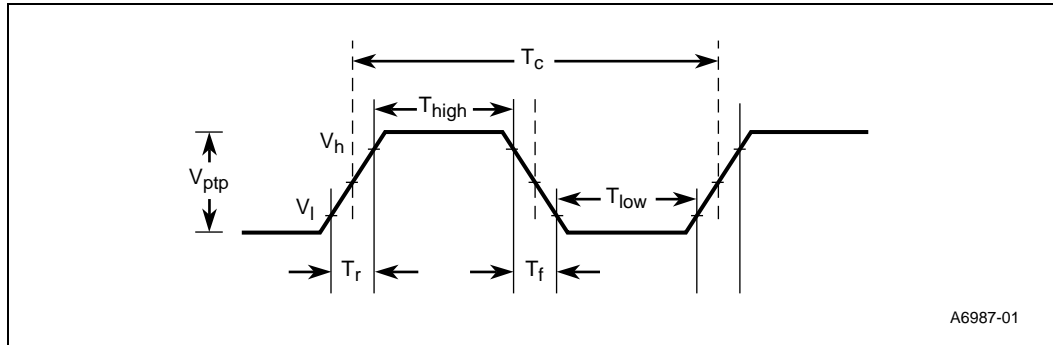

Table 44. FCLK Signal AC Parameter Measurements

Symbol	Parameter	Minimum	Maximum	Unit
$F_{CLK}$	Clock frequency	10	$104^1$	MHz
$T_c$	Cycle time	$9.62^1$	100	ns
$T_{high}^2$	Clock high time	3.8	---	ns
$T_{low}^2$	Clock low time	3.8	---	ns
$V_{ptp}$	Clock peak to peak <sup>2</sup>	$0.6 \cdot V_{DDX}$	---	V
$T_r, T_f$	Clock rise/fall time <sup>3</sup>	1	4	ns
	$F_{core}/F_{CLK}$ Clock Ratio	1.5:1		

1. Maximum  $F_{CLK}$  frequency for 232 MHz rated parts is 104 MHz. Maximum  $F_{CLK}$  frequency for 200 MHz rated parts is 85 MHz. Maximum  $F_{CLK}$  frequency for 166 MHz rated parts is 66 MHz.
2.  $T_{high}$  and  $T_{low}$  are based on a 50% duty cycle and can vary (worst case) 45-55%.
3. Nominal  $V_{ptp} = 0.12 \cdot V_{DDX}$  to  $0.75 \cdot V_{DDX}$ .



### 7.3.7.2 IX Bus Signals Timing

Figure 20. IX Bus Signals Timing

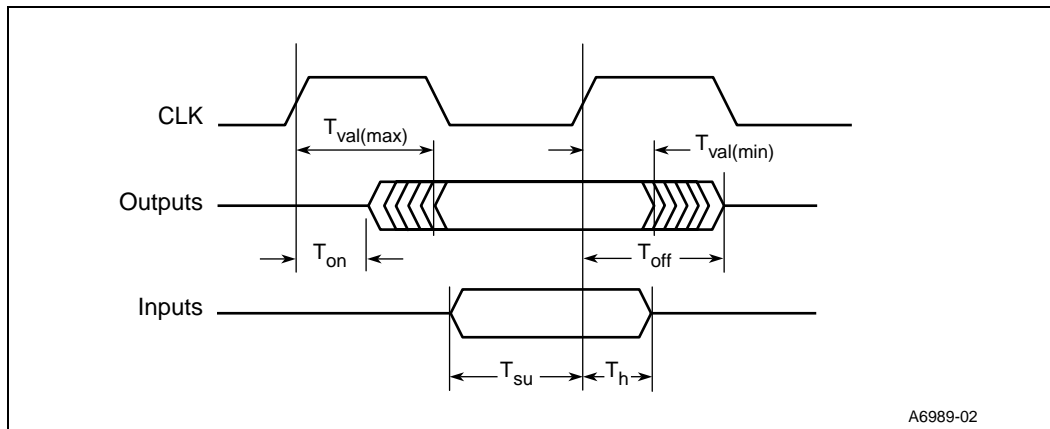

Table 45. IX Bus Signals Timing

Symbol	Parameter	Minimum (IX Bus Speed)			Maximum (IX Bus Speed)			Unit	Condition
		66 MHz	85 MHz	104 MHz	66 MHz	85 MHz	104 MHz		
$T_{val}$	Clock to output delay	1.0	1.0	0.5	7.0	7.0	5.75	ns	0 pF load <sup>1</sup>
$T_{su}$	Data input setup time before clock	4.0	4.0	3.25	---	---	---	ns	
$T_h$	Data input hold time from clock	1.0	1.0	0.25	---	---	---	ns	
$T_{on}$	Float to FDAT[63:0] and FBE#[7:0] data driven delay from clock <sup>2</sup>	1.5	1.5	1.5	--	--	--	ns	
$T_{onxf}$	Float to data driven from clock, excluding FDAT[63:0] and FBE#[7:0] <sup>2</sup>	2.5	2.5	2.5	--	--	--	ns	
$T_{off}$	FDAT[63:0] and FBE#[7:0] driven to float delay from clock <sup>2</sup>	---	---	---	7.5	7.5	7.5	ns	
$T_{offxf}$	Data driven to float delay, excluding FDAT[63:0] and FBE#[7:0] <sup>2</sup>	---	---	---	7.0	7.0	7.0	ns	

1. Capacitive loading effects on signal lines are shown in Table 46.
2. The parameter specified is guaranteed by design in a minimally configured system environment.

Table 46. Signal Delay Derating

Signal	Maximum Derating (ns/pF)			Minimum Derating (ns/pF)		
	66 MHz	85 MHz	104 MHz	66 MHz	85 MHz	104 MHz
FDATA[63:0]	0.055	0.05	0.031	0.03	0.025	0.015
FBE#[7:0]	0.055	0.05	0.031	0.03	0.025	0.015
FPS[2:0]	0.065	0.06	0.031	0.03	0.025	0.015
TK_REQ_OUT	0.065	0.06	0.031	0.03	0.025	0.015
TK_REQ_IN	0.065	0.06	0.031	0.03	0.025	0.015
RDYCTL#[4:0]	0.065	0.06	0.031	0.03	0.025	0.015
RDYBUS[7:0]	0.065	0.06	0.031	0.03	0.025	0.015
TXAXIS	0.065	0.06	0.031	0.03	0.025	0.015
EOP	0.065	0.06	0.031	0.03	0.025	0.015
SOP	0.065	0.06	0.031	0.03	0.025	0.015
GPIO[3:0]	0.065	0.06	0.031	0.03	0.025	0.015
PORTCTL#[3:0]	0.095	0.09	0.035	0.03	0.025	0.015
TK_OUT	0.095	0.09	0.035	0.03	0.025	0.015
RXFAIL	0.095	0.09	0.035	0.03	0.025	0.015

## 7.3.7.3 IX Bus Protocol

The following timing diagrams show the IX Bus signal protocol for both 64-bit Bidirectional and 32-bit Unidirectional modes of operation.

Figure 21. 64-Bit Bidirectional IX Bus Timing, 1-2 MAC Mode, Consecutive Receive and Transmit, No EOP

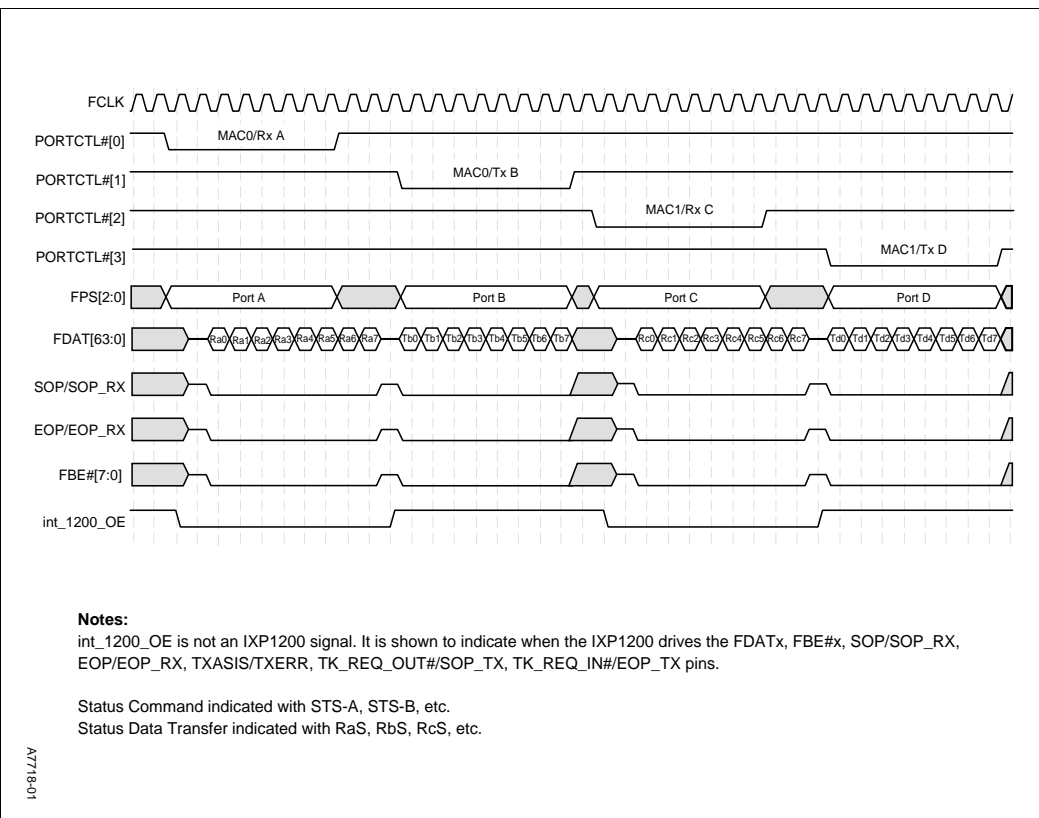

Figure 22. 64-Bit Bidirectional IX Bus Timing - Consecutive Receive and Transmit, No EOP

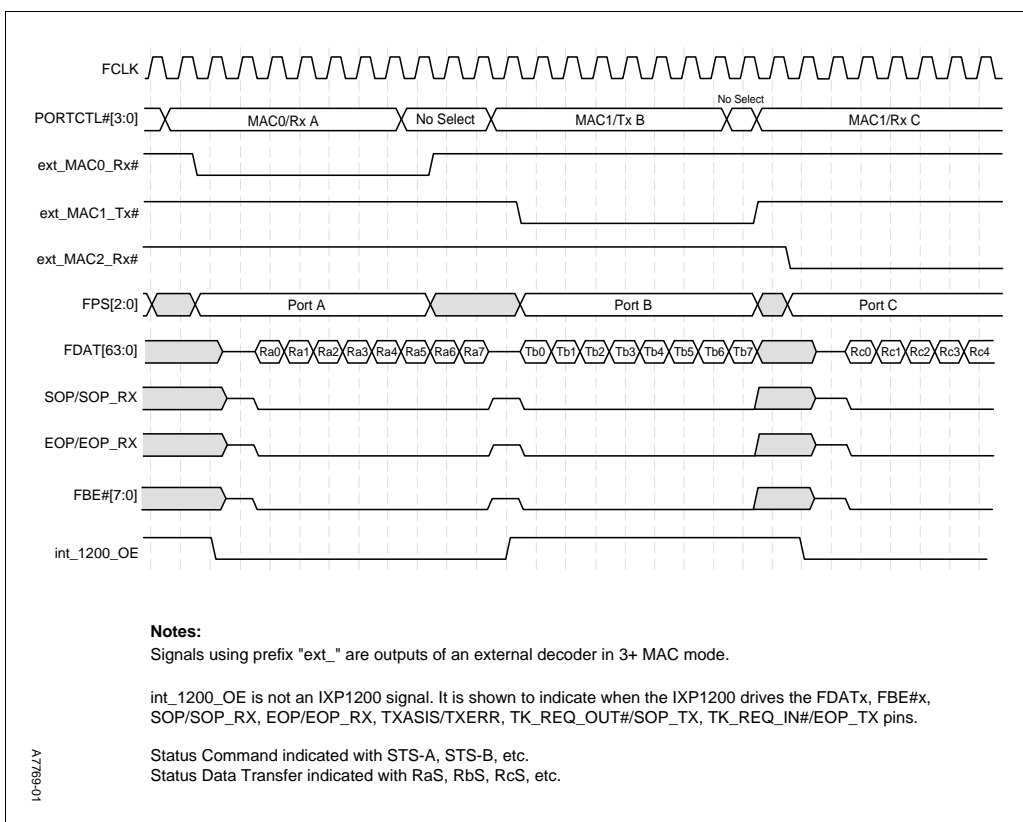

Figure 23. 64-Bit Bidirectional IX Bus Timing - Consecutive Receive and Transmit, EOP on 8th Data Return with Status

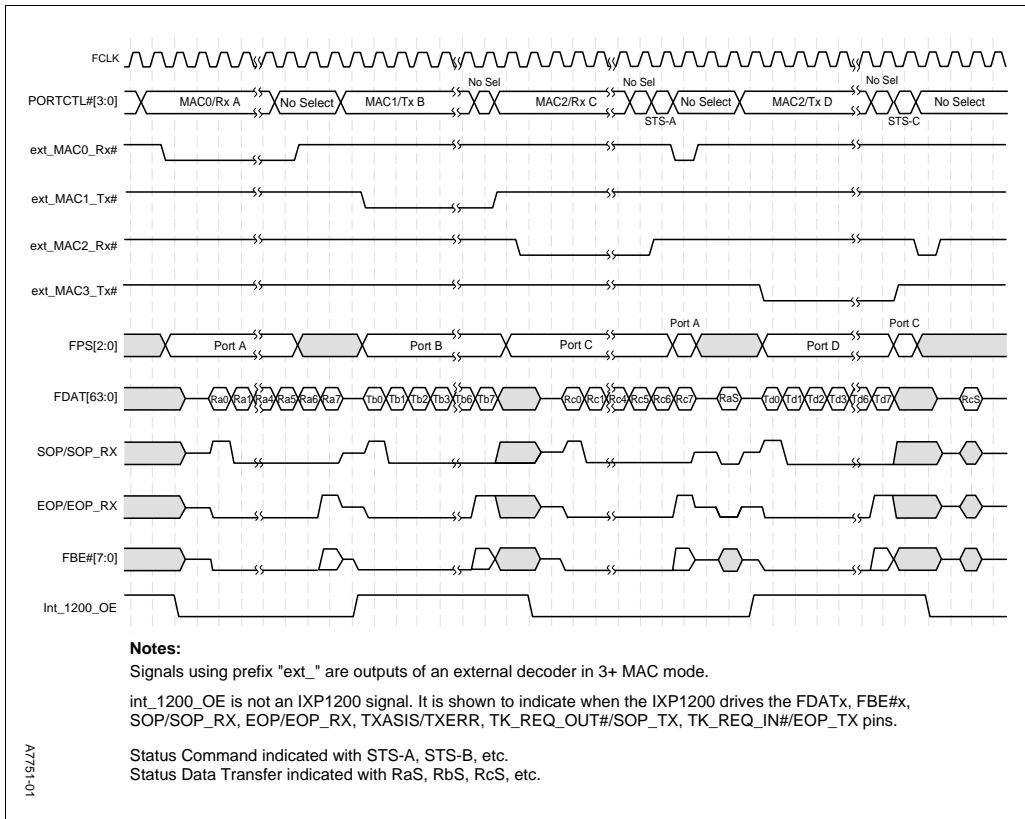

Figure 24. 64-Bit Bidirectional IX Bus Timing - Consecutive Receive and Transmit, EOP on 7th Data Return with Status

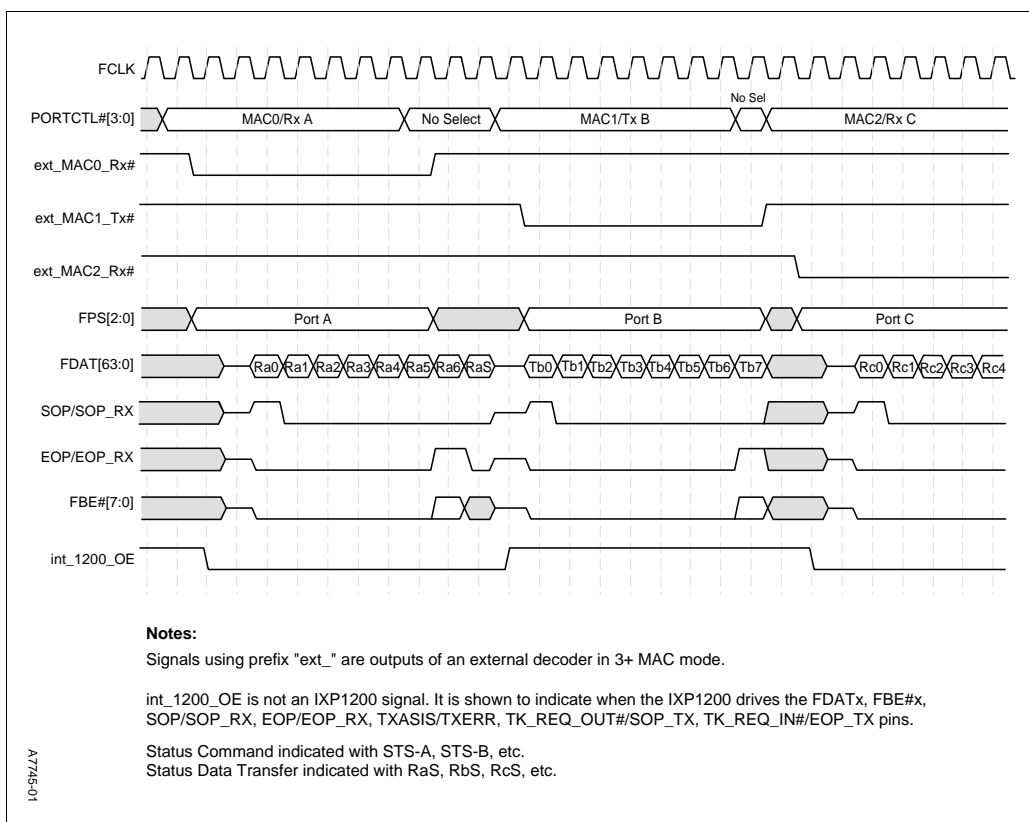

Figure 25. 64-Bit Bidirectional IX Bus Timing - Consecutive Receive and Transmit, EOP on 6th Data Return with Status

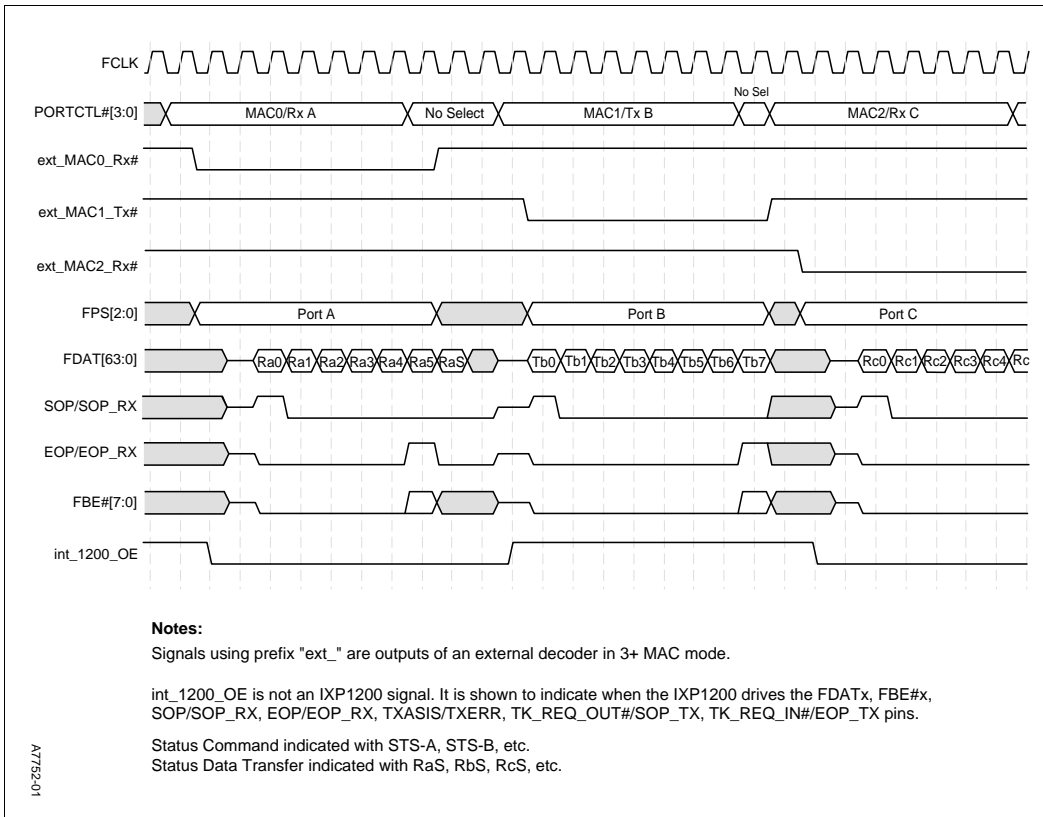

Figure 26. 64-Bit Bidirectional IX Bus Timing - Consecutive Receive and Transmit, EOP on 5th Data Return with Status

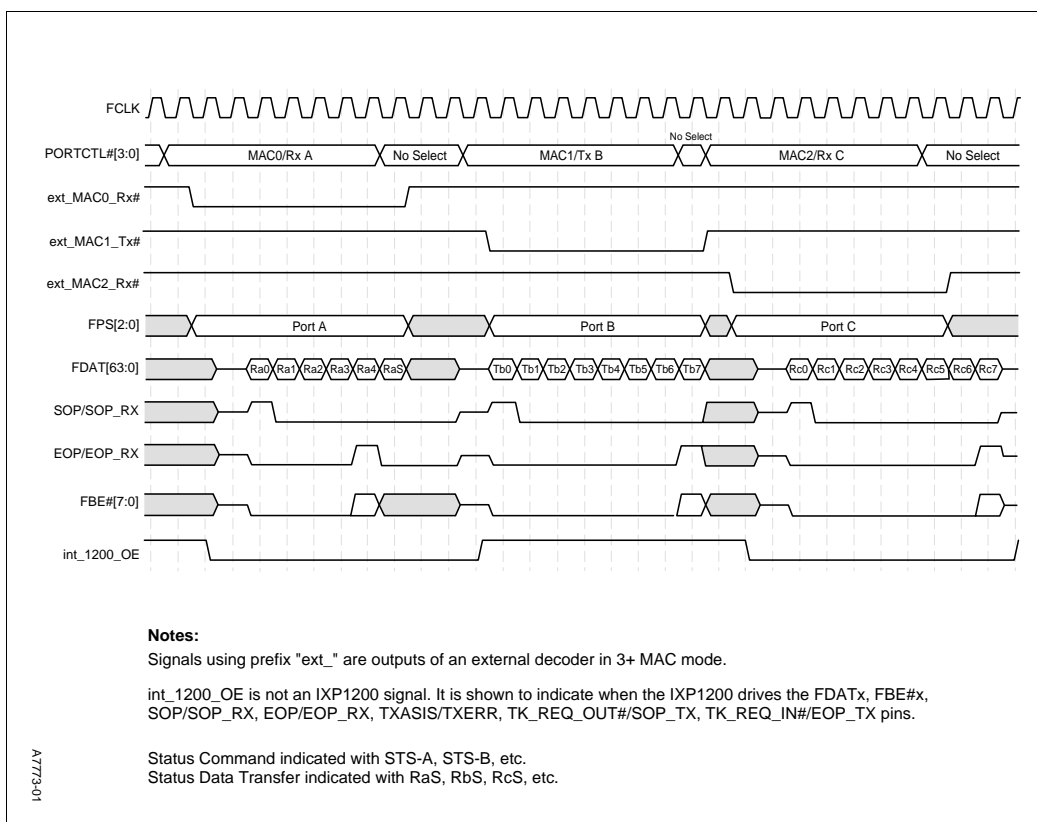



Figure 27. 64-Bit Bidirectional IX Bus Timing - Consecutive Receive and Transmit, EOP on 4th Data Return with Status

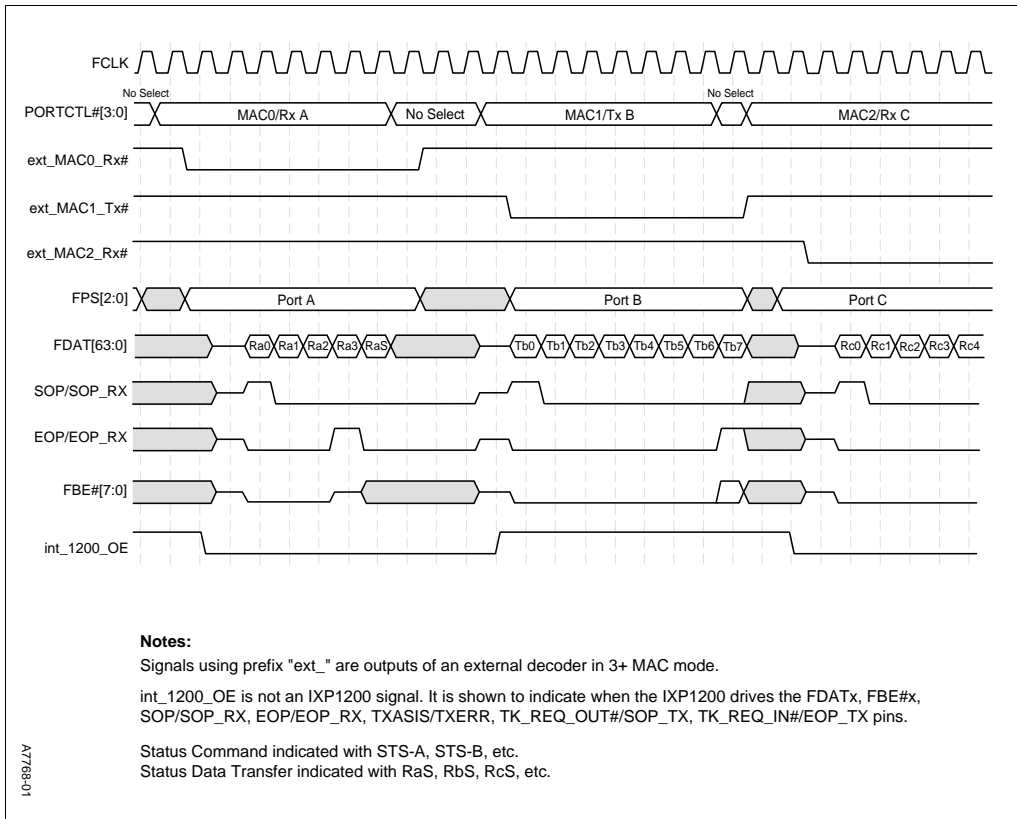

Figure 28. 64-Bit Bidirectional IX Bus Timing - Consecutive Receive and Transmit, EOP on 1st through 3rd Data Return with Status (3rd Data Return Shown)

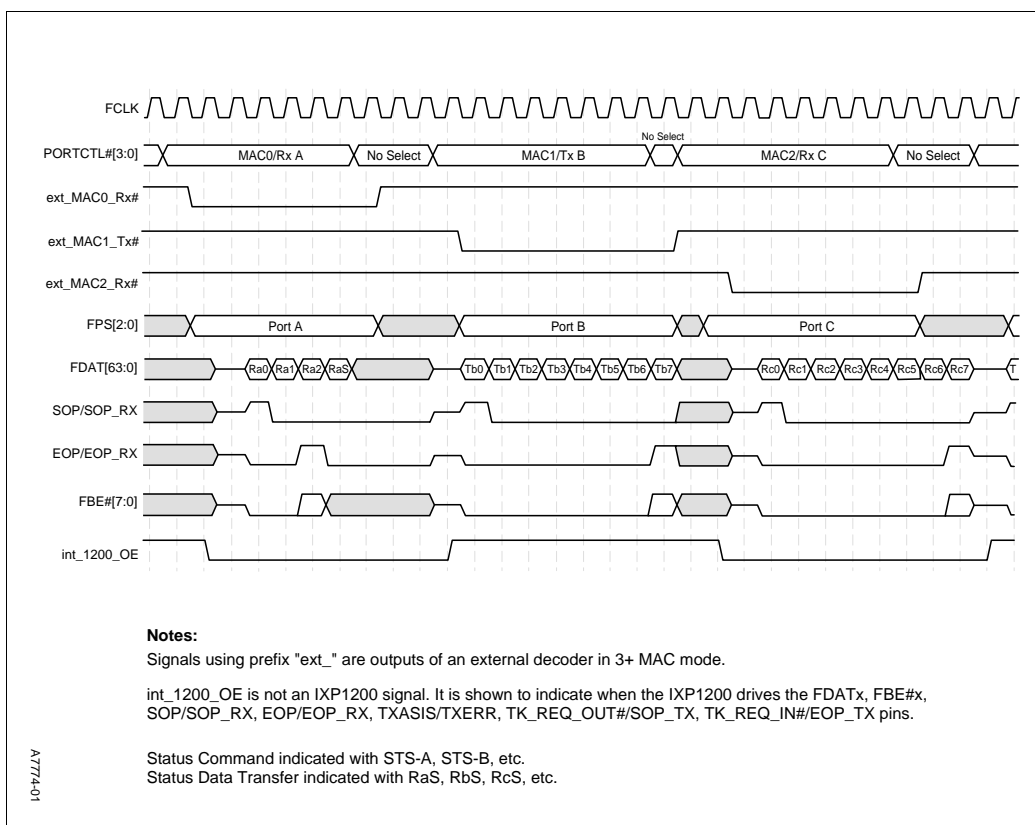

Figure 29. 64-Bit Bidirectional IX Bus Timing - Consecutive Receives, EOP on 1st Data Return, No Status

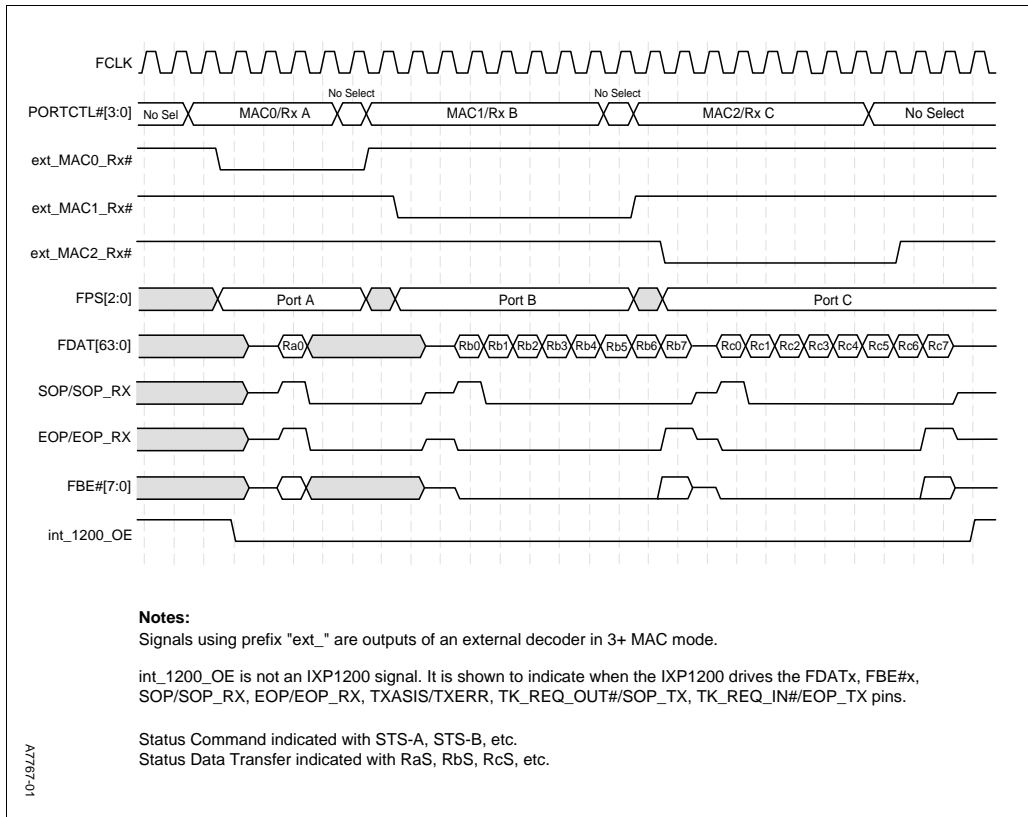

Figure 30. 64-Bit Bidirectional IX Bus Timing - Consecutive Receives, No EOP

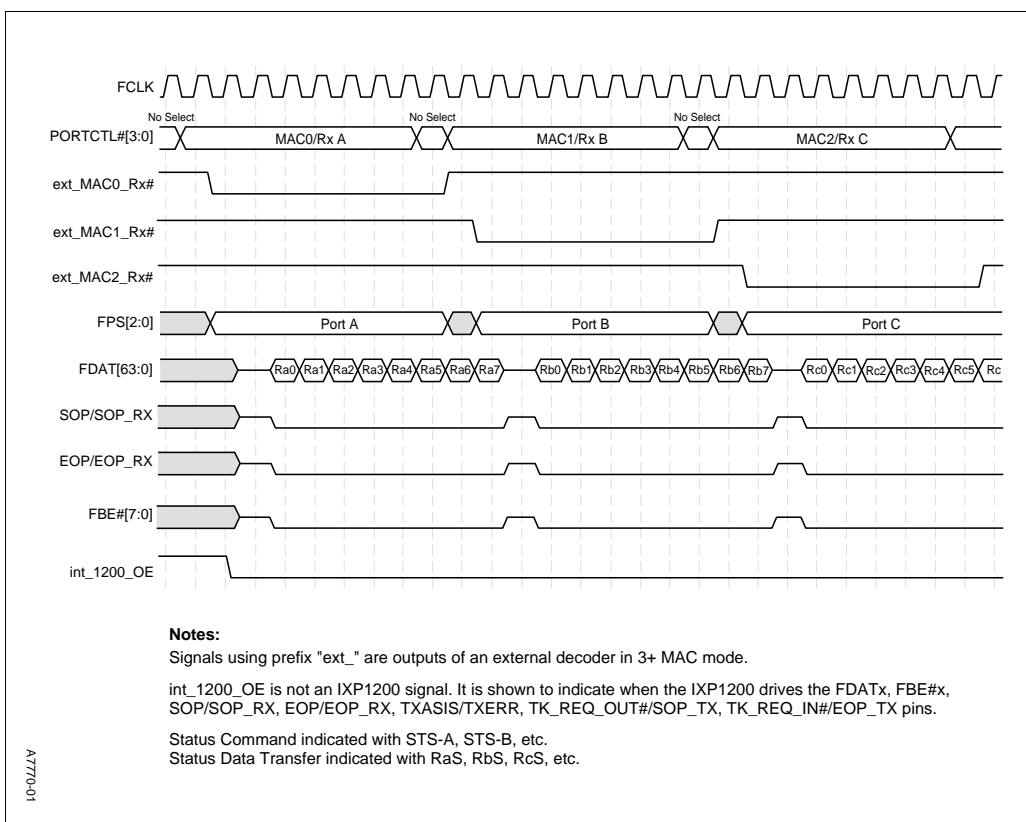

Figure 31. 64-Bit Bidirectional IX Bus Timing - Consecutive Receives, EOP on 8th Data Return with Status

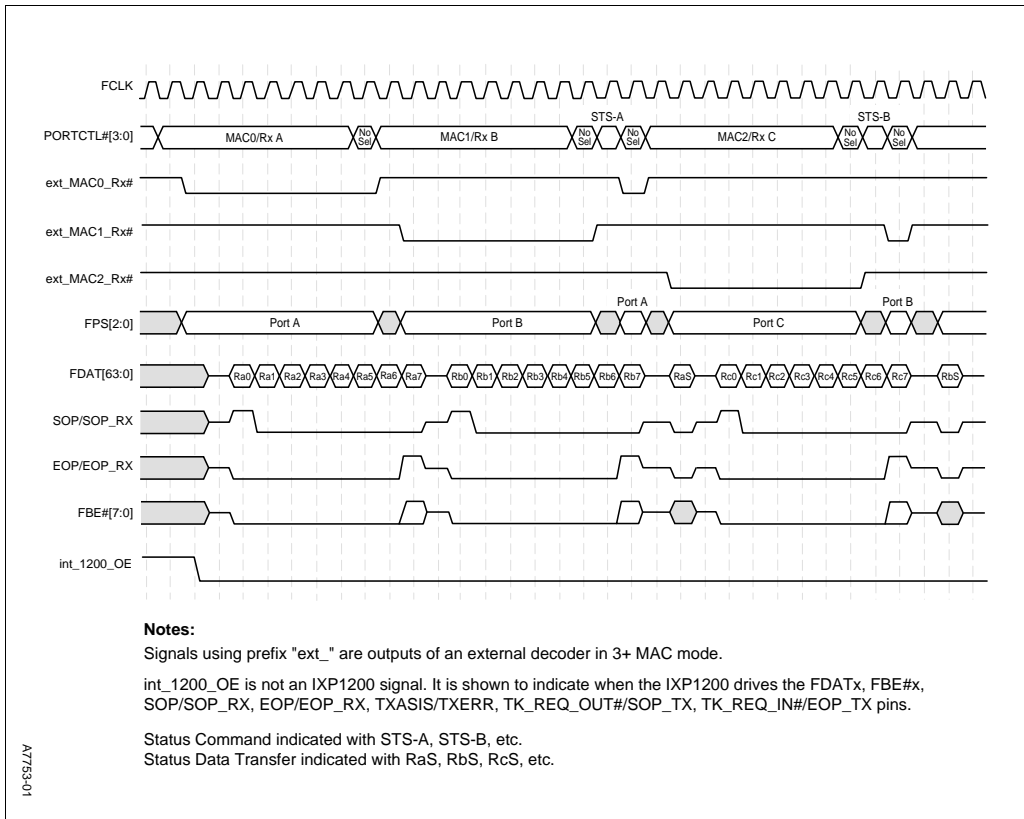

Figure 32. 64-Bit Bidirectional IX Bus Timing - Consecutive Receives, EOP on 7th Data Return with Status

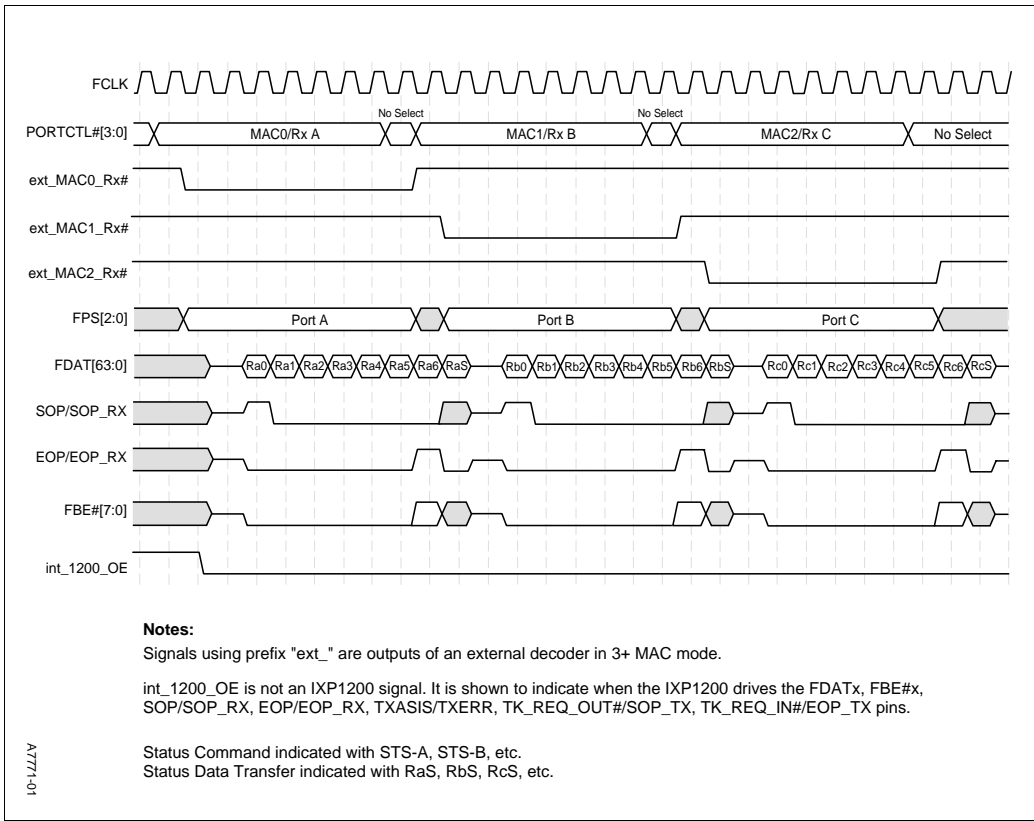

Figure 33. 64-Bit Bidirectional IX Bus Timing - Consecutive Receives, EOP on 6th Data Return with Status

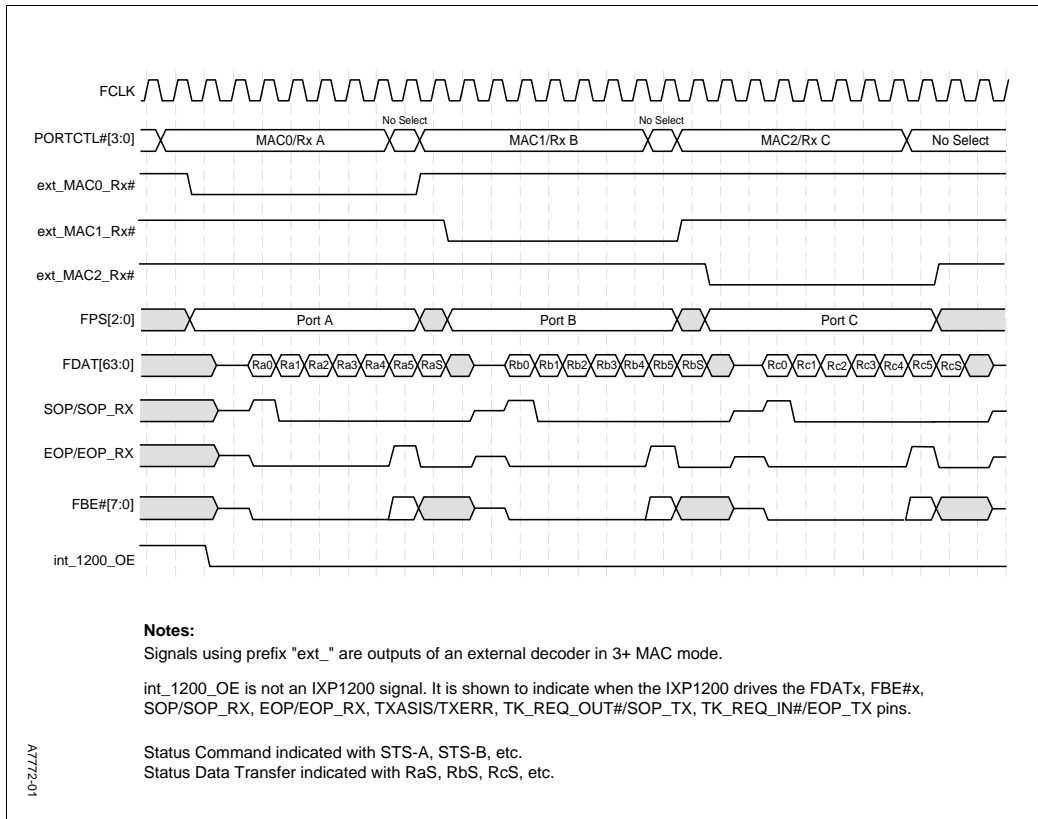

Figure 34. 64-Bit Bidirectional IX Bus Timing - Consecutive Receives, EOP, Two Element Transfer with Status

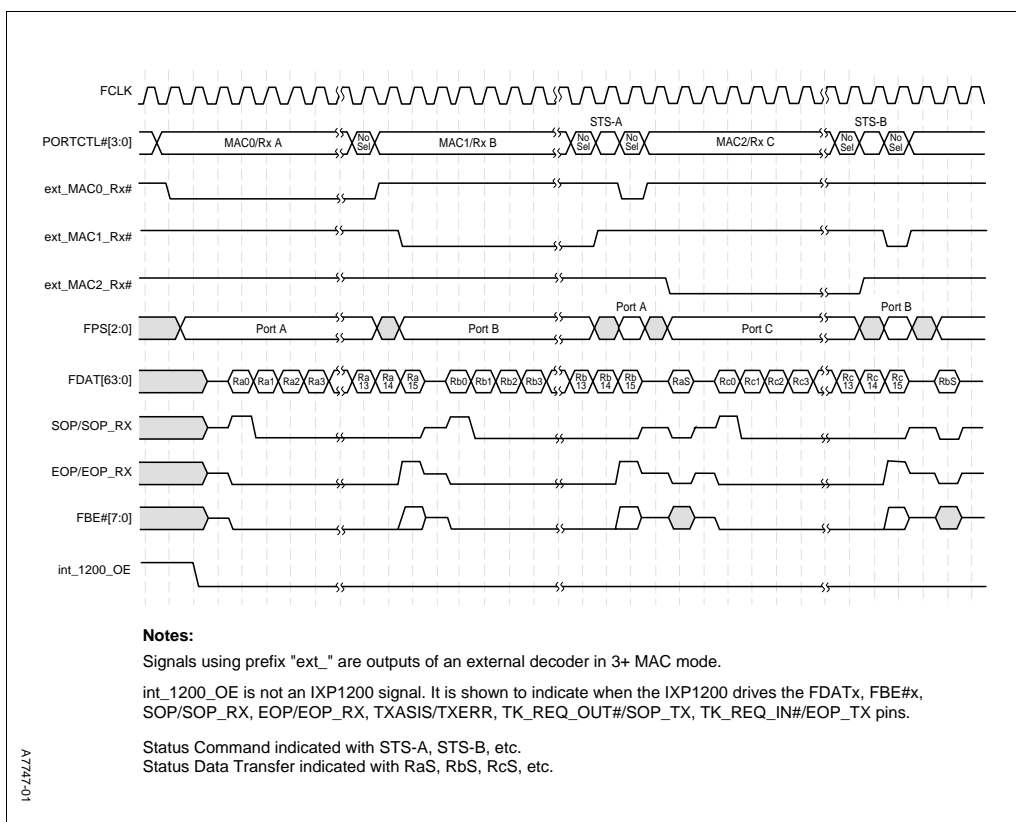



Figure 35. 64-Bit Bidirectional Ix Bus Timing - Consecutive Receives, Fetch-9, No EOP

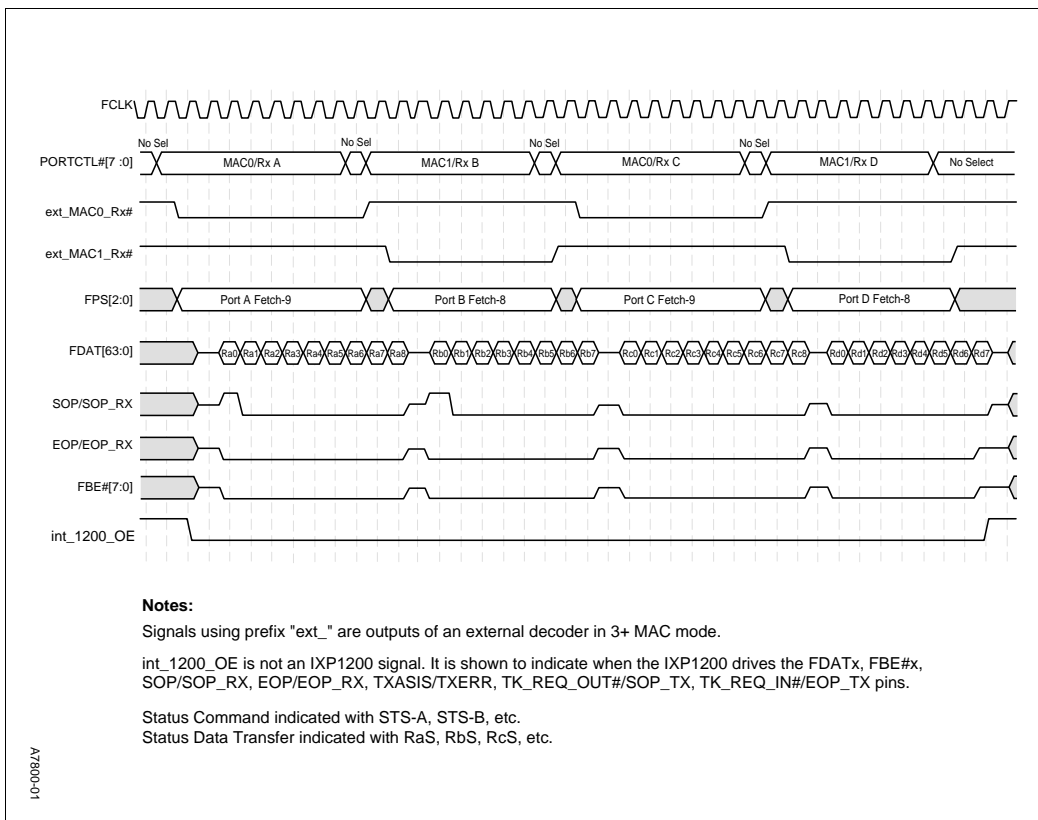

Figure 36. 64-Bit Bidirectional IX Bus Timing - Consecutive Transmits, EOP

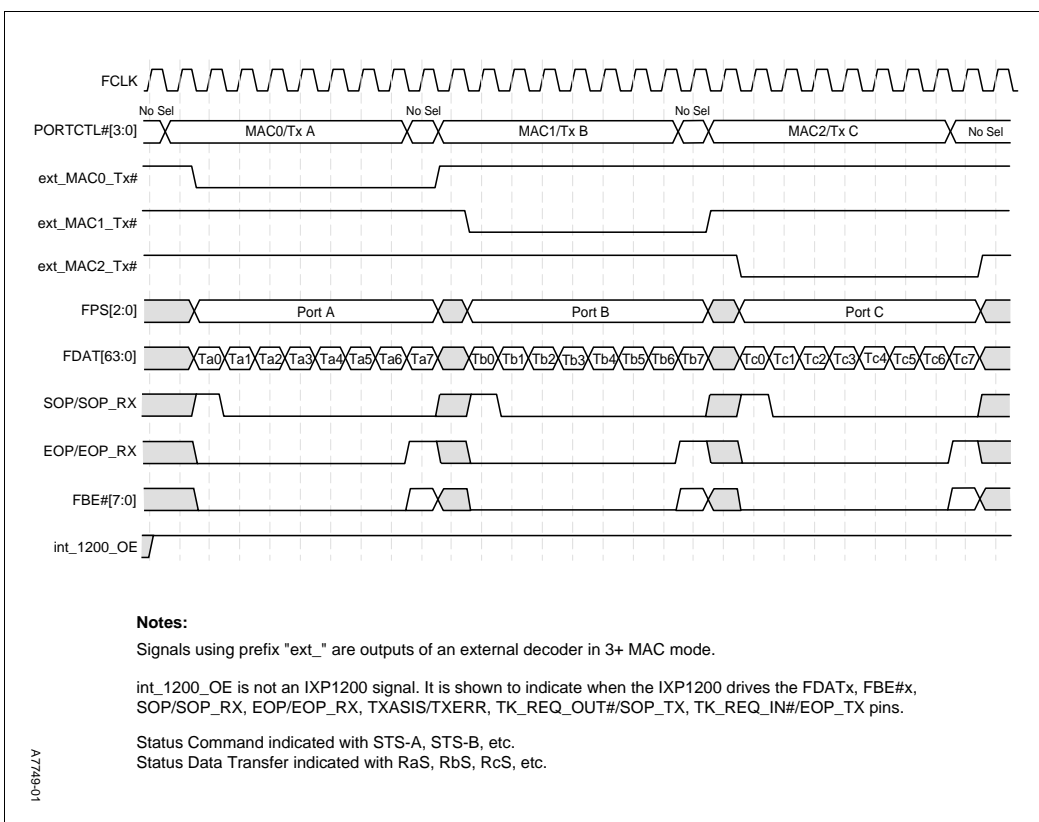

Figure 37. 64-Bit Bidirectional IX Bus Timing - Consecutive Transmits with Prepend, EOP

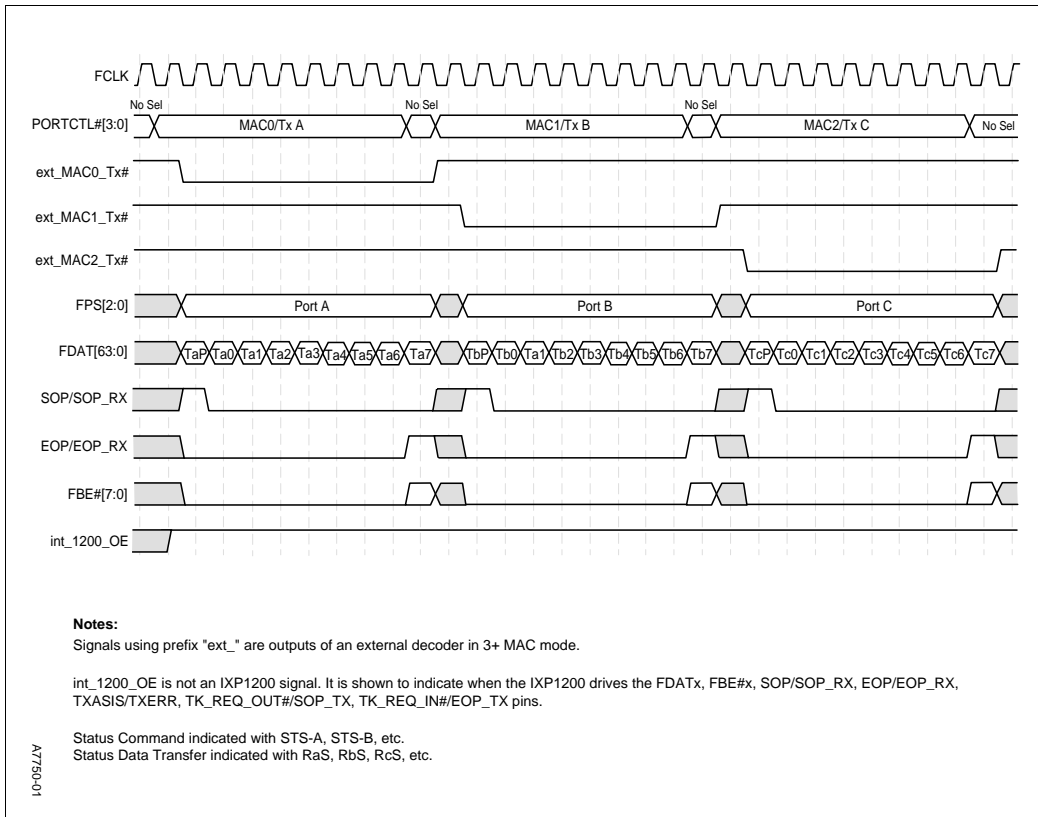

Figure 38. 32-Bit Unidirectional IX Bus Timing - Consecutive Receives, No EOP

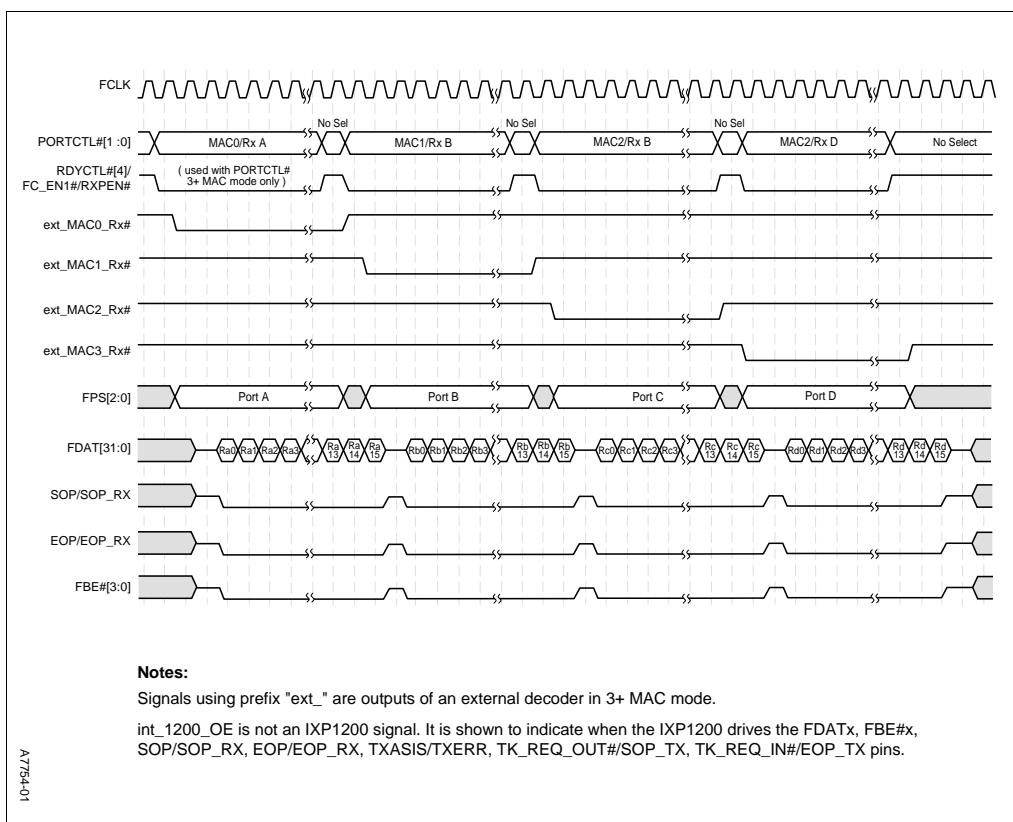

Figure 39. 32-Bit Unidirectional IX Bus Timing - Consecutive Receives, EOP on 16th Data Return with Status

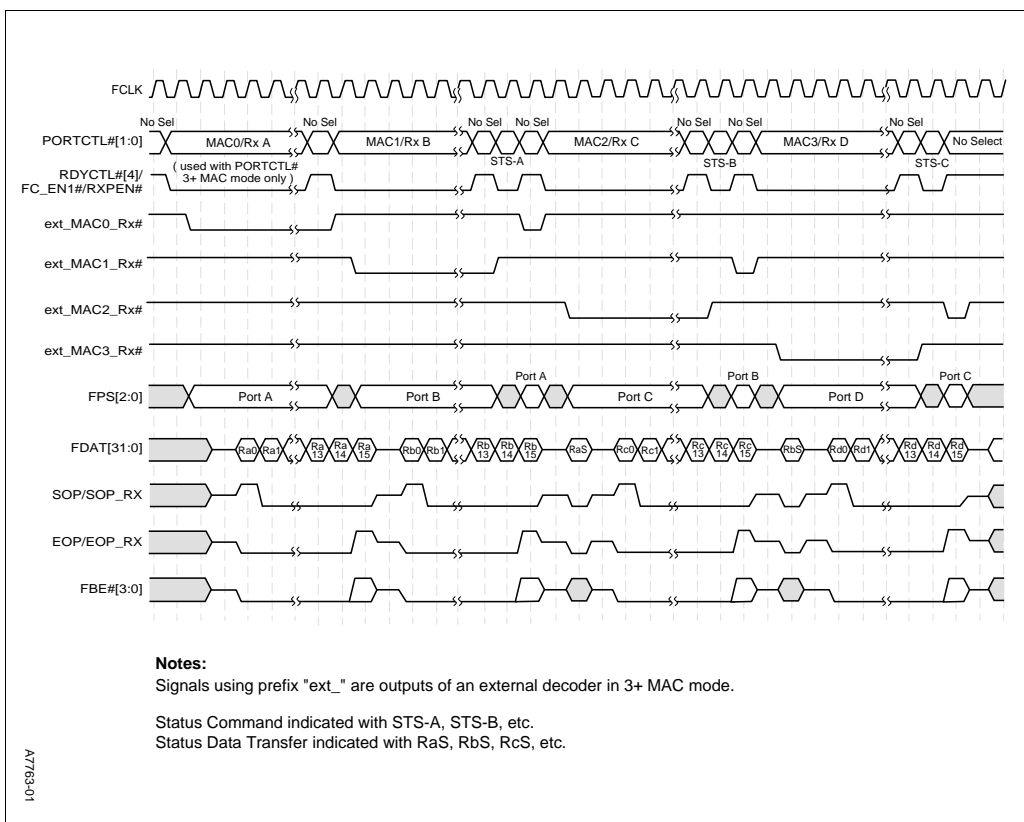

Figure 40. 32-Bit Unidirectional IX Bus Timing - Consecutive Receives, EOP on 15th Data Return with Status

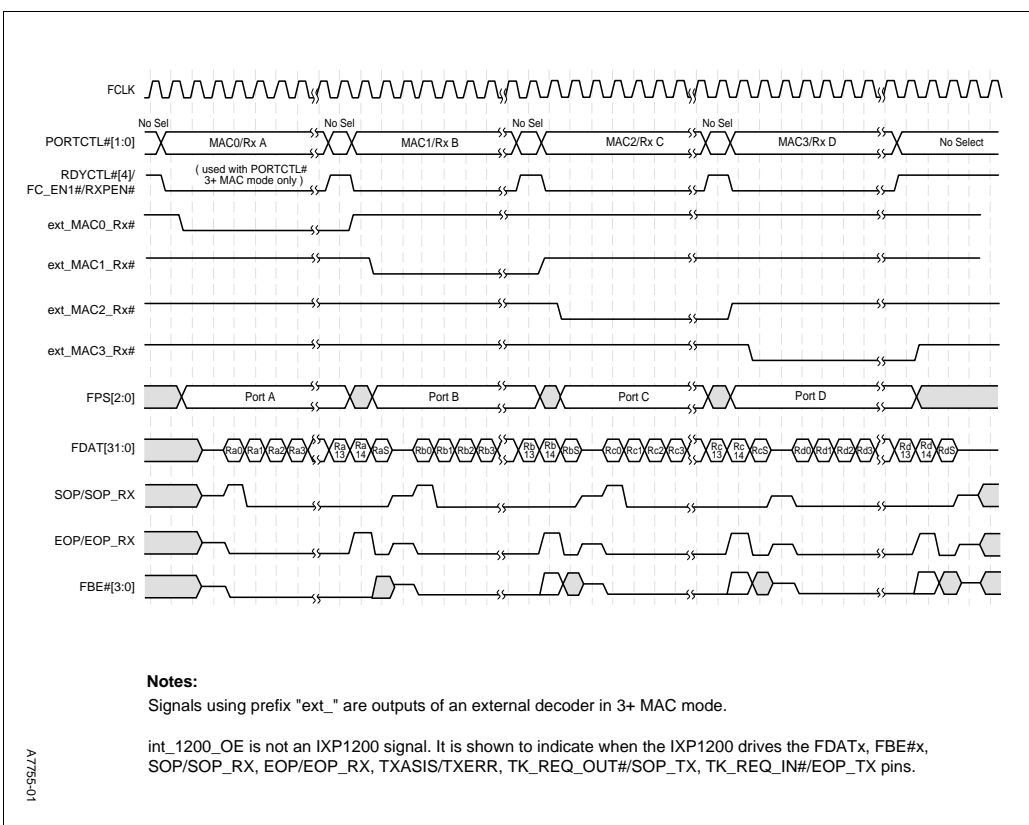

Figure 41. 32-Bit Unidirectional IX Bus Timing - Consecutive Receives, EOP on 14th Data  
Return with Status

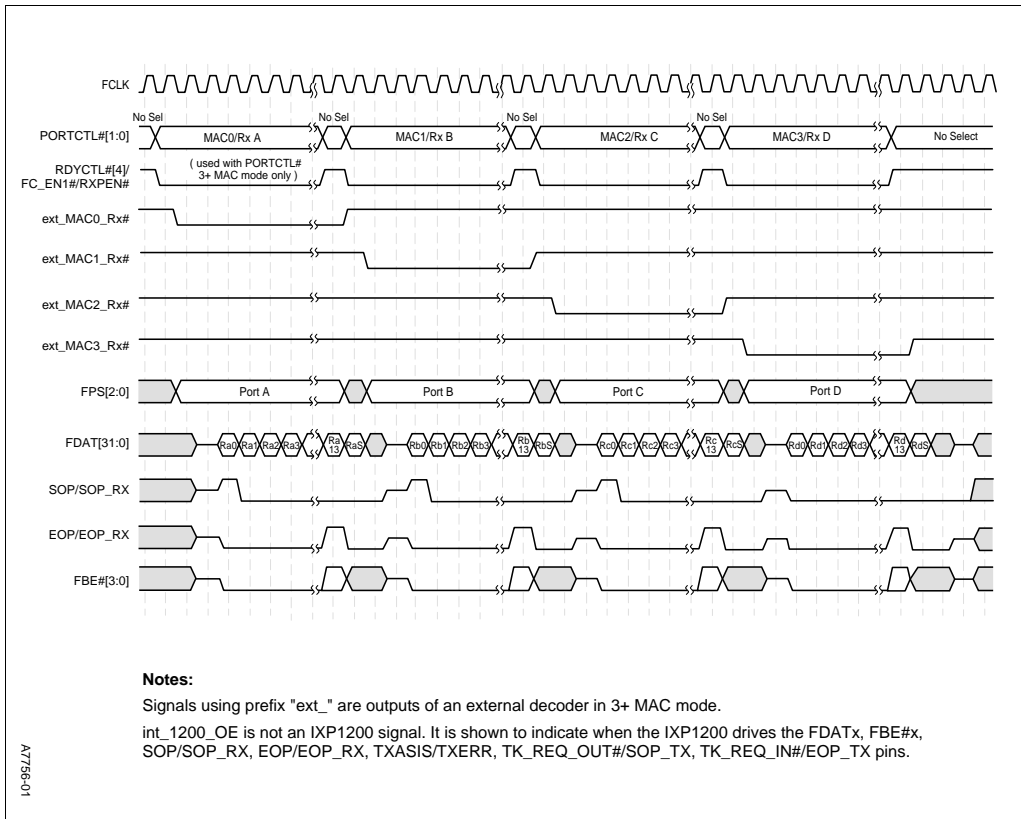

Figure 42. 32-Bit Unidirectional IX Bus Timing - Consecutive Receives, EOP on 1st Through 13th Data Return with Status (13th Data Return Shown)

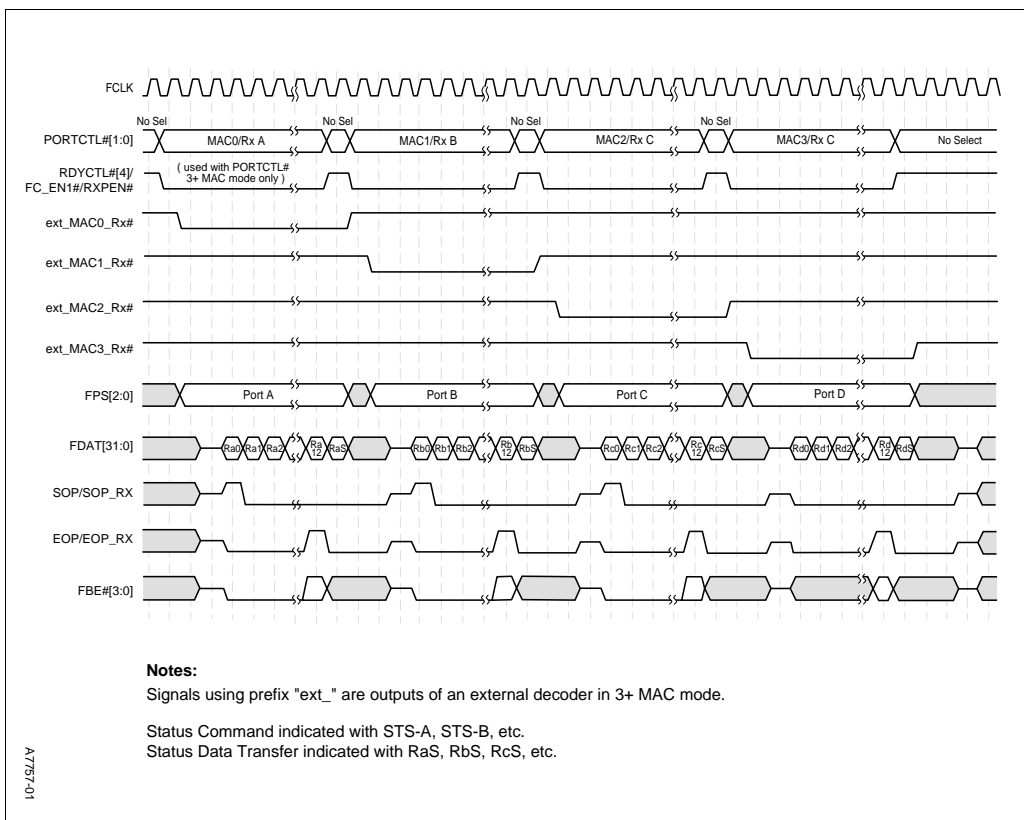



Figure 43. 32-Bit Unidirectional IX Bus Timing - Consecutive Receives, EOP, 64-Bit Status

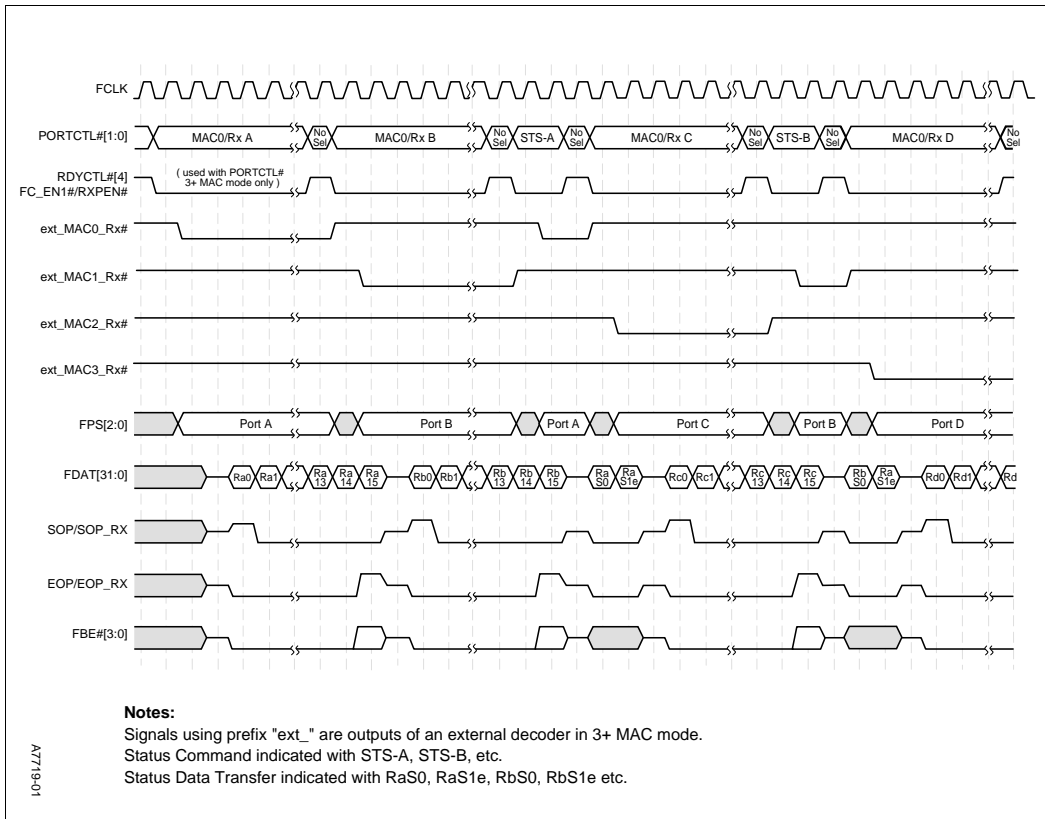

Figure 44. 32-Bit Unidirectional IX Bus Timing - Consecutive Receives, Two Element Transfers with 32-Bit Status

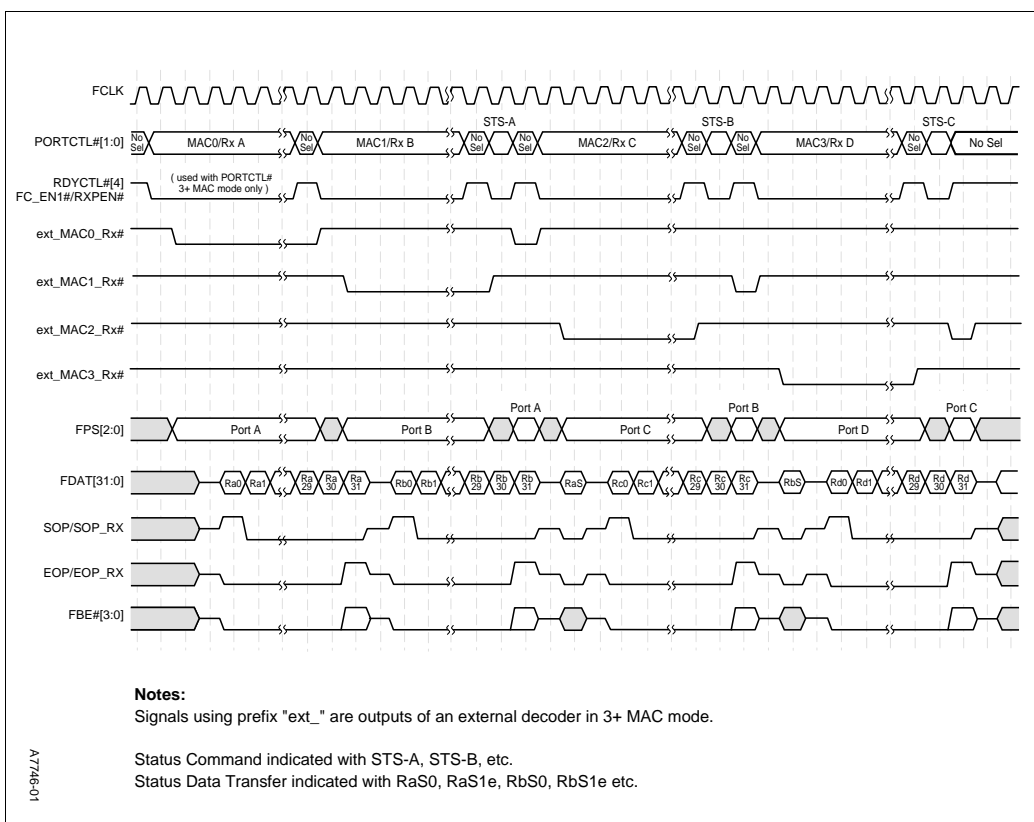

Figure 45. 32-Bit Unidirectional IX Bus Timing - Consecutive Transmits, EOP

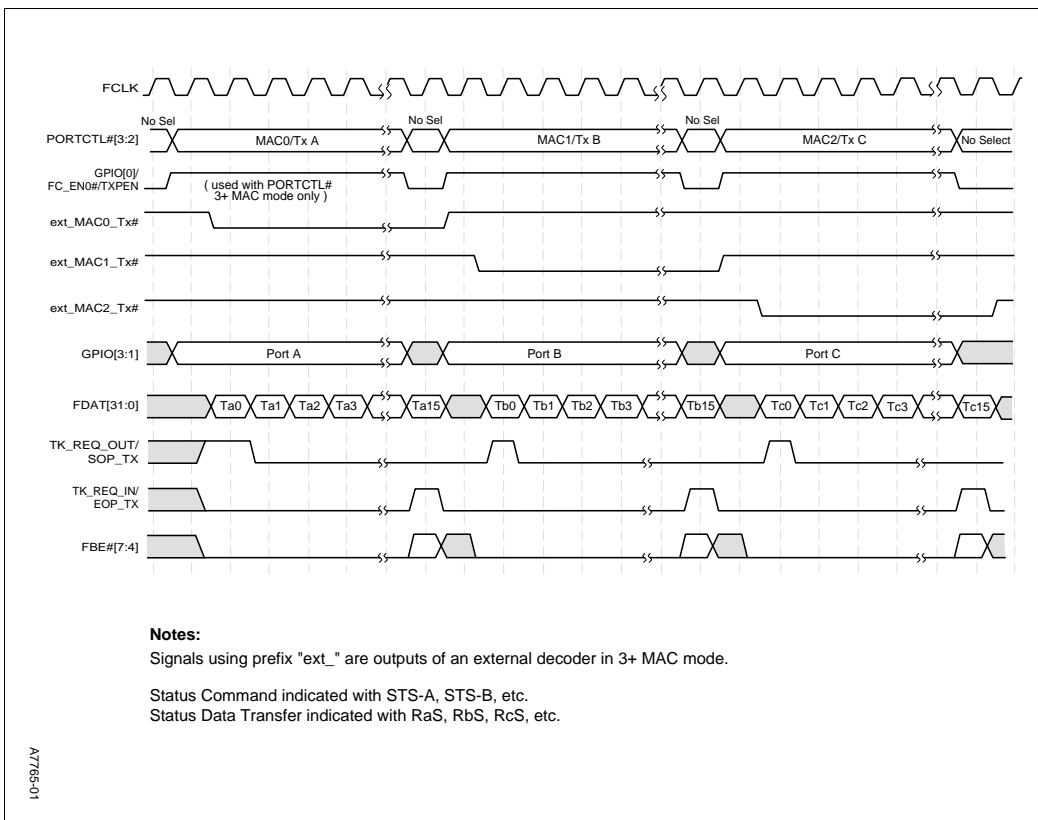

Figure 46. 32-Bit Unidirectional IX Bus Timing - Consecutive Transmits with Prepend, EOP

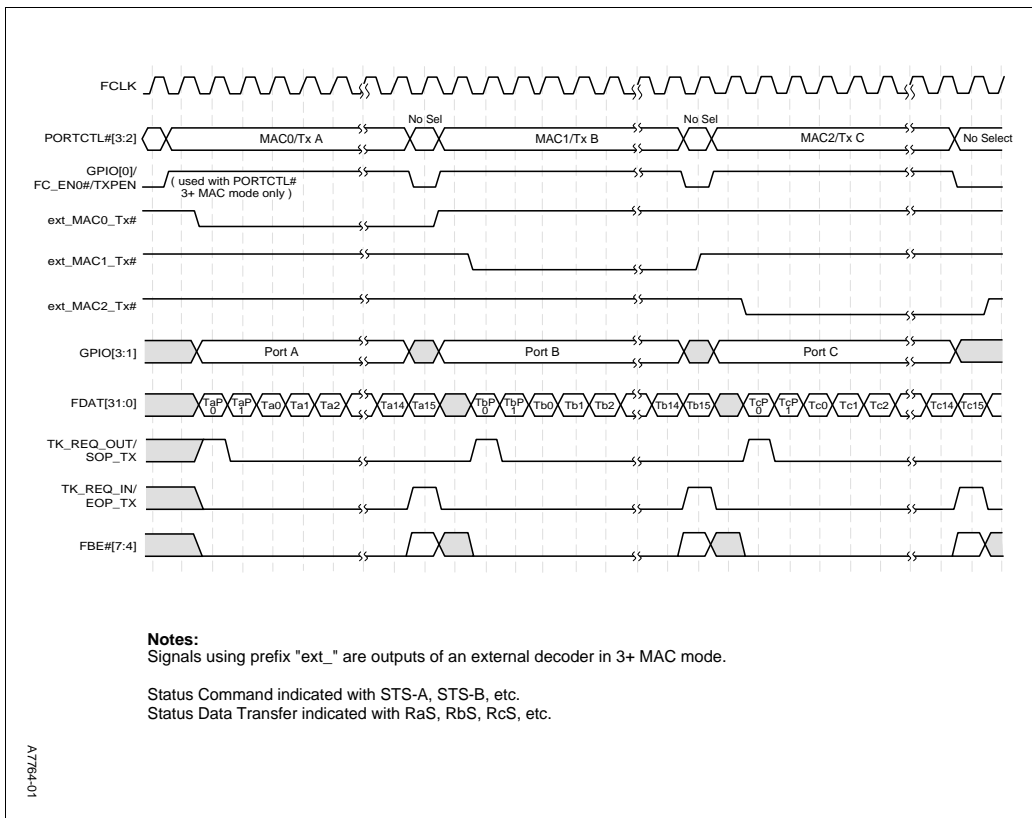

Figure 47. 64-Bit Bidirectional IX Bus Timing - Consecutive FastPort Receives, Same Port, EOP, No Status, FP\_READY\_WAIT=0

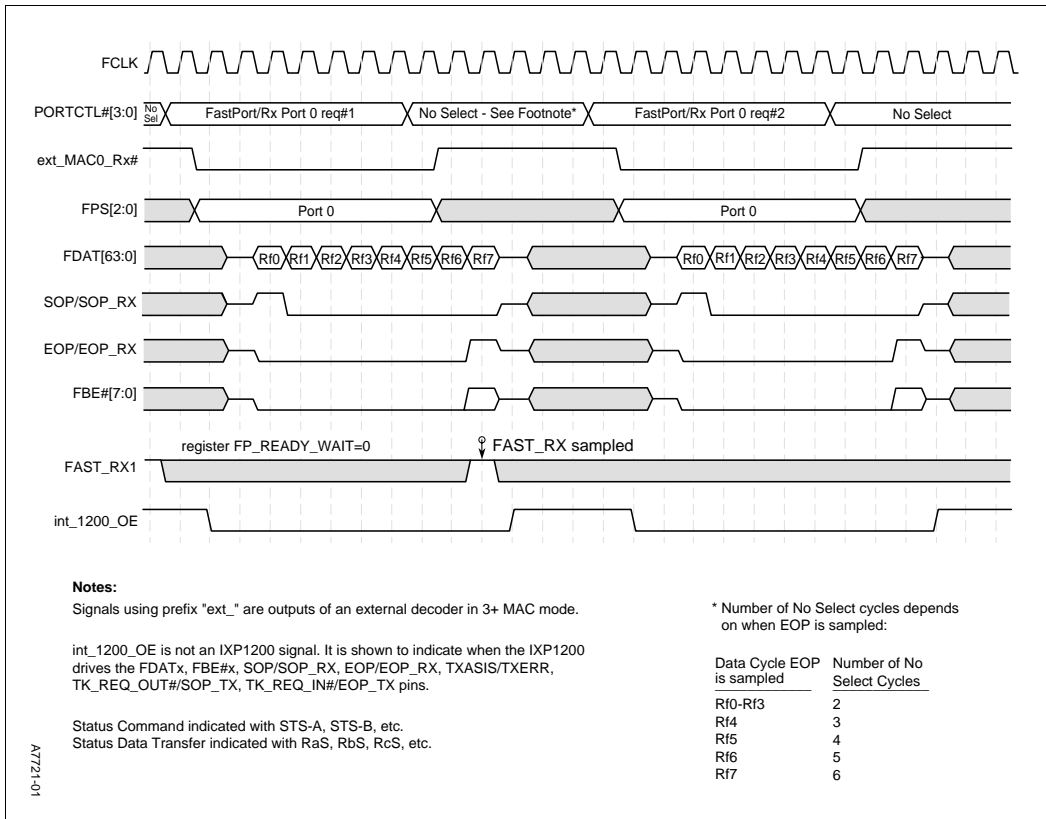

Figure 48. 64-Bit Bidirectional IX Bus Timing - Consecutive FastPort Receives, Same Port, EOP, No Status, FP\_READY\_WAIT=5

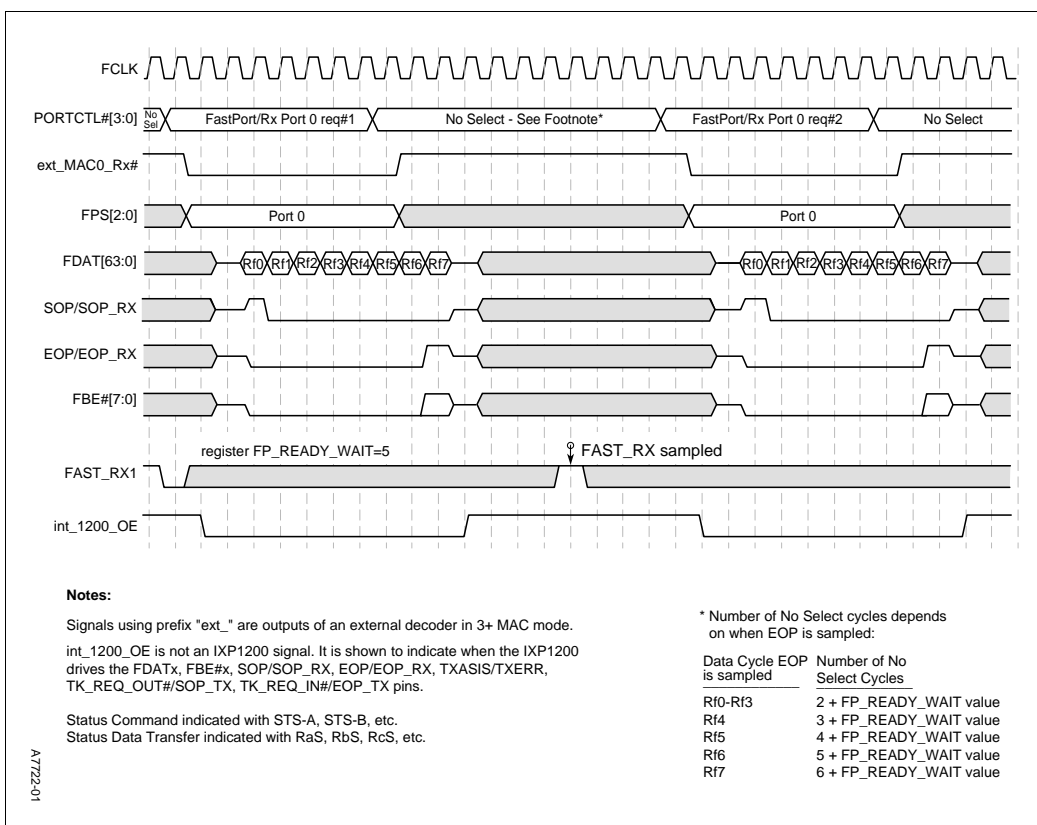

Figure 49. 64-Bit Bidirectional IX Bus Timing - Consecutive FastPort Receives, Same Port, EOP, with Status, FP\_READY\_WAIT=0

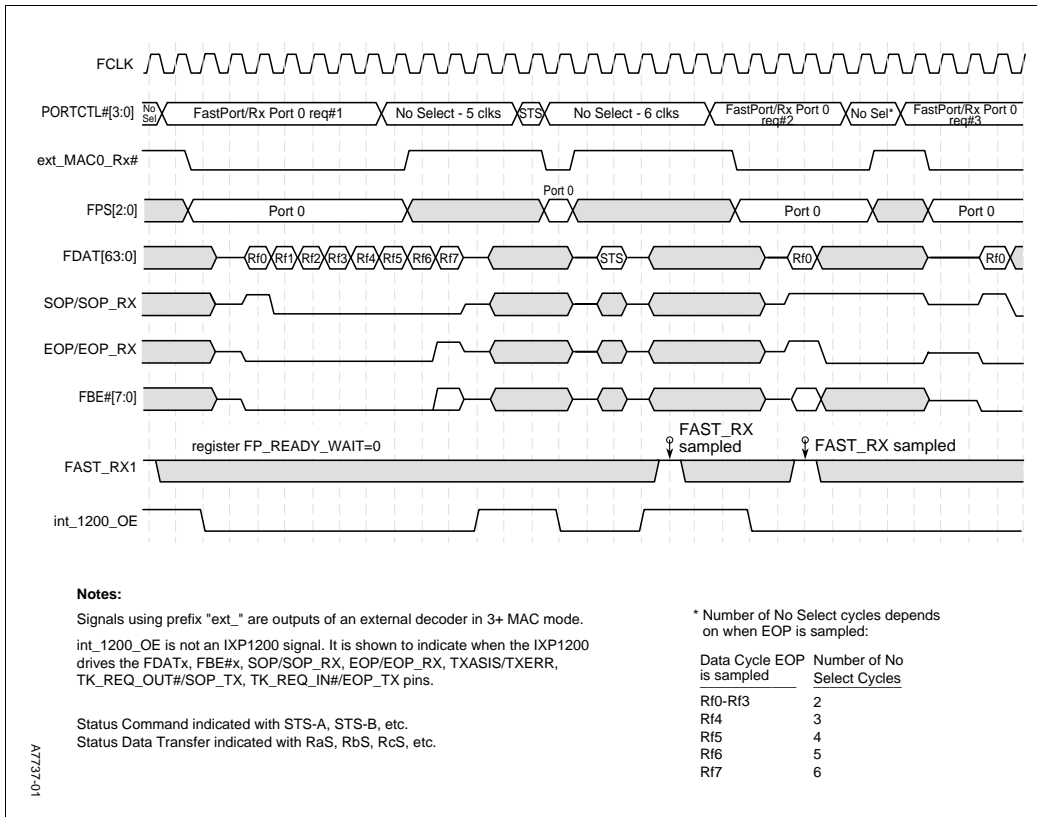

Figure 50. 64-Bit Bidirectional IX Bus Timing - Consecutive FastPort Receives, Same Port, EOP, No Status, FP\_READY\_WAIT=5

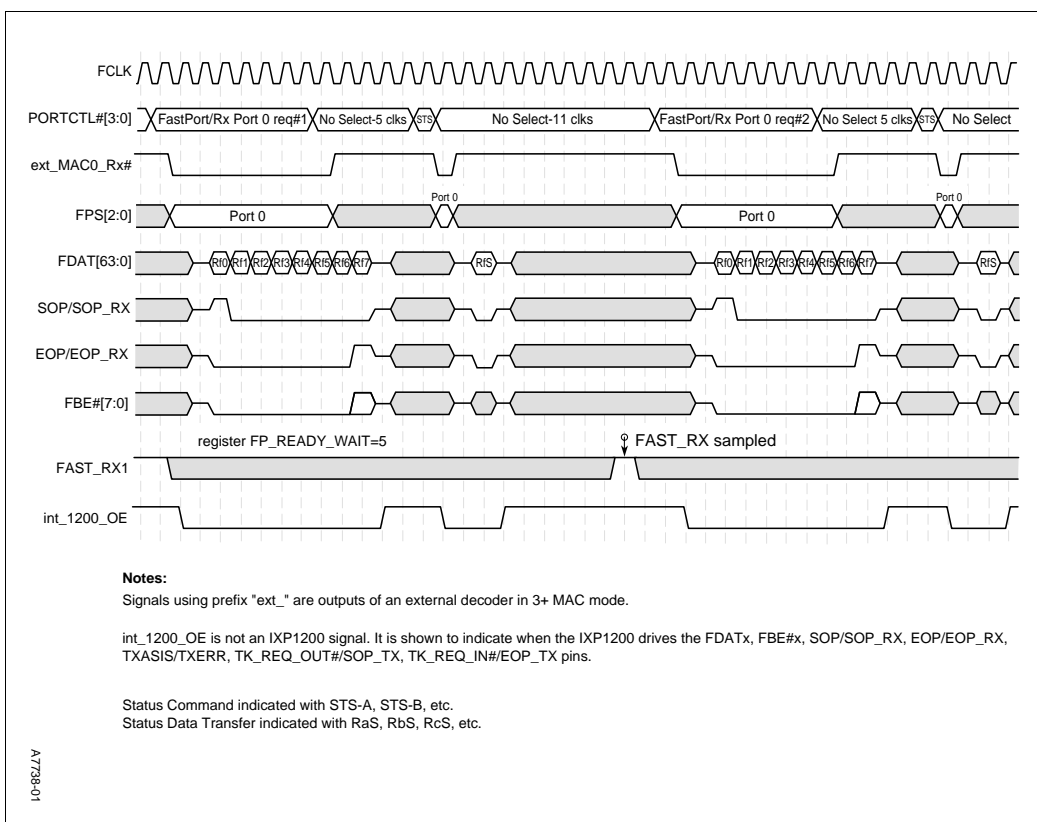



Figure 51. 64-Bit Bidirectional IX Bus Timing - Consecutive FastPort Receives, Same Port, EOP, No Status, FP\_READY\_WAIT=0, Cancelled Request

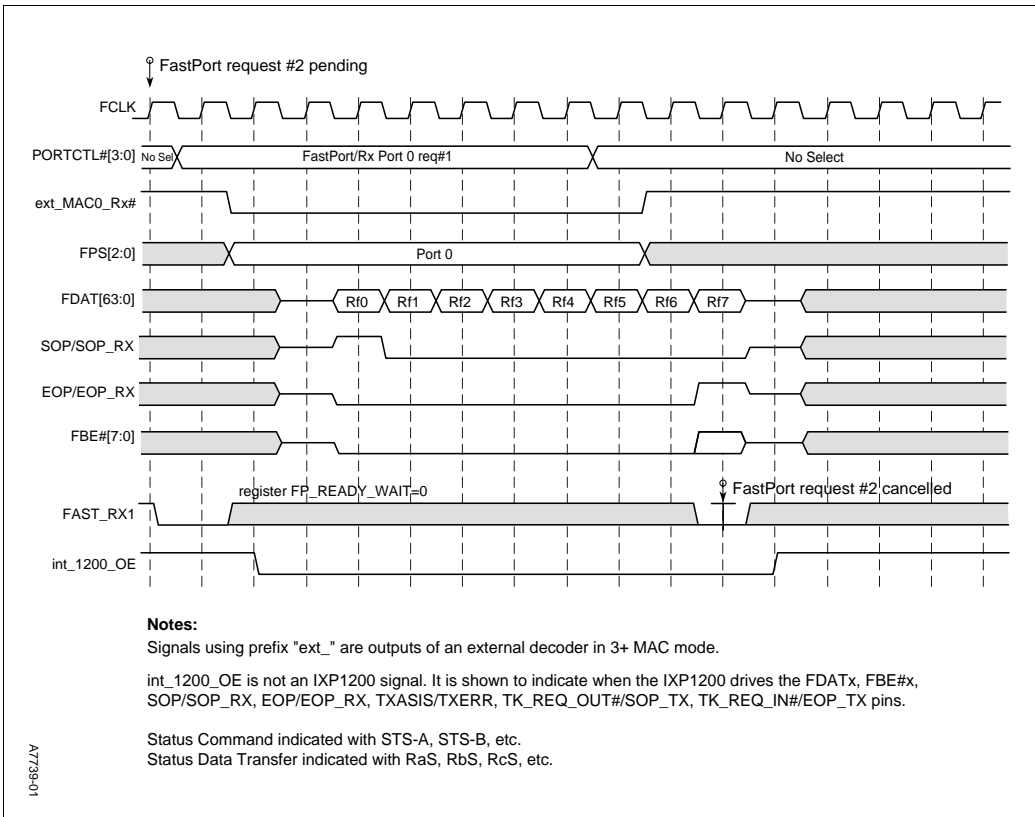

Figure 52. 64-Bit Bidirectional IX Bus Timing - Consecutive FastPort Receives, Same Port, No EOP, FP\_READY\_WAIT=Don't Care

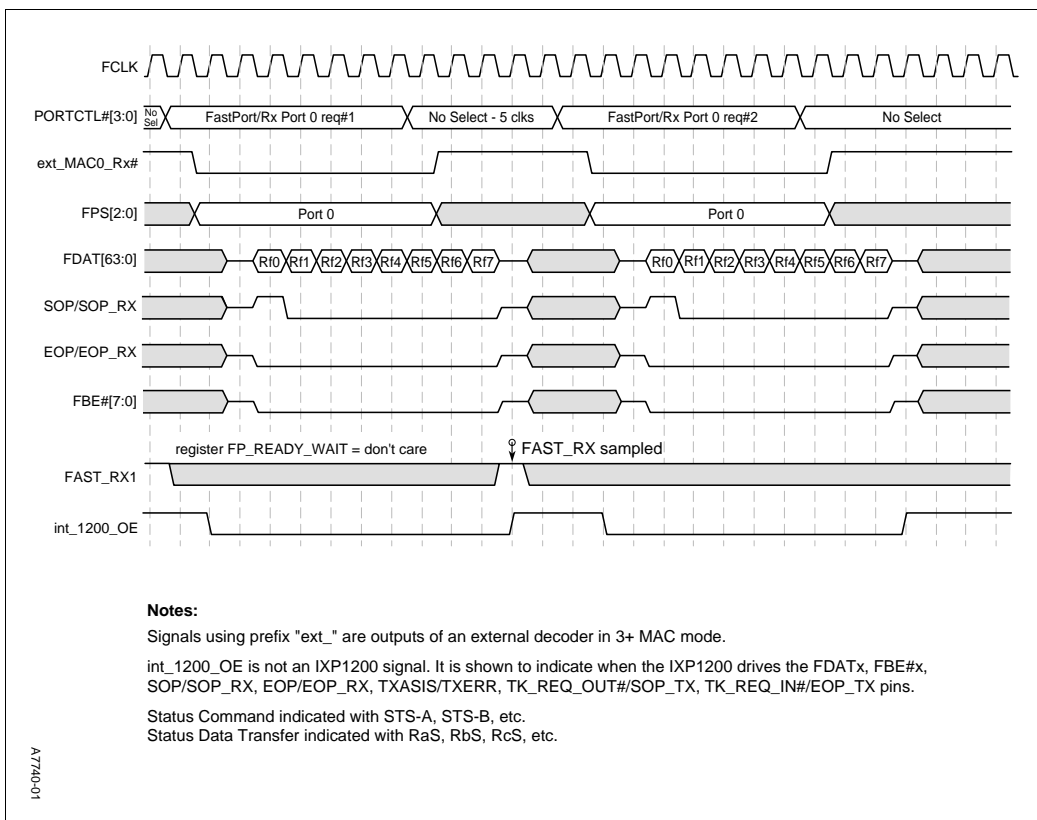

Figure 53. 64-Bit Bidirectional IX Bus Timing - Consecutive FastPort Receives, Different Ports, EOP, No Status, FP\_READY\_WAIT=0

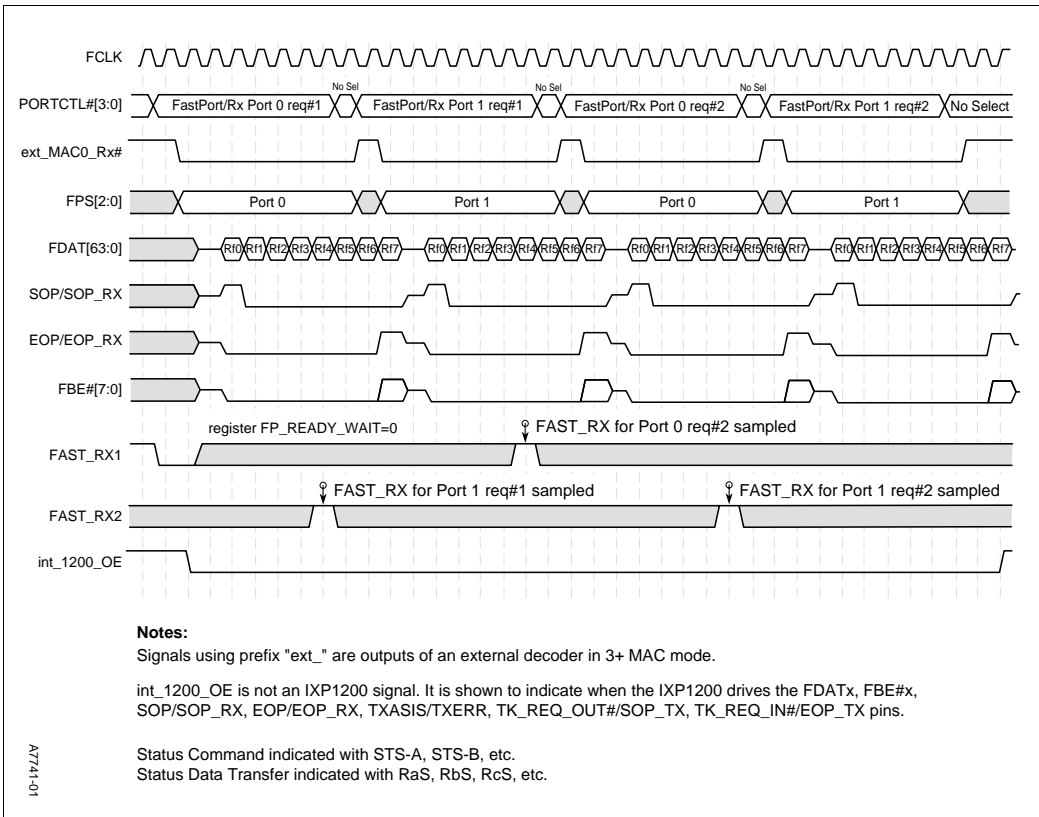
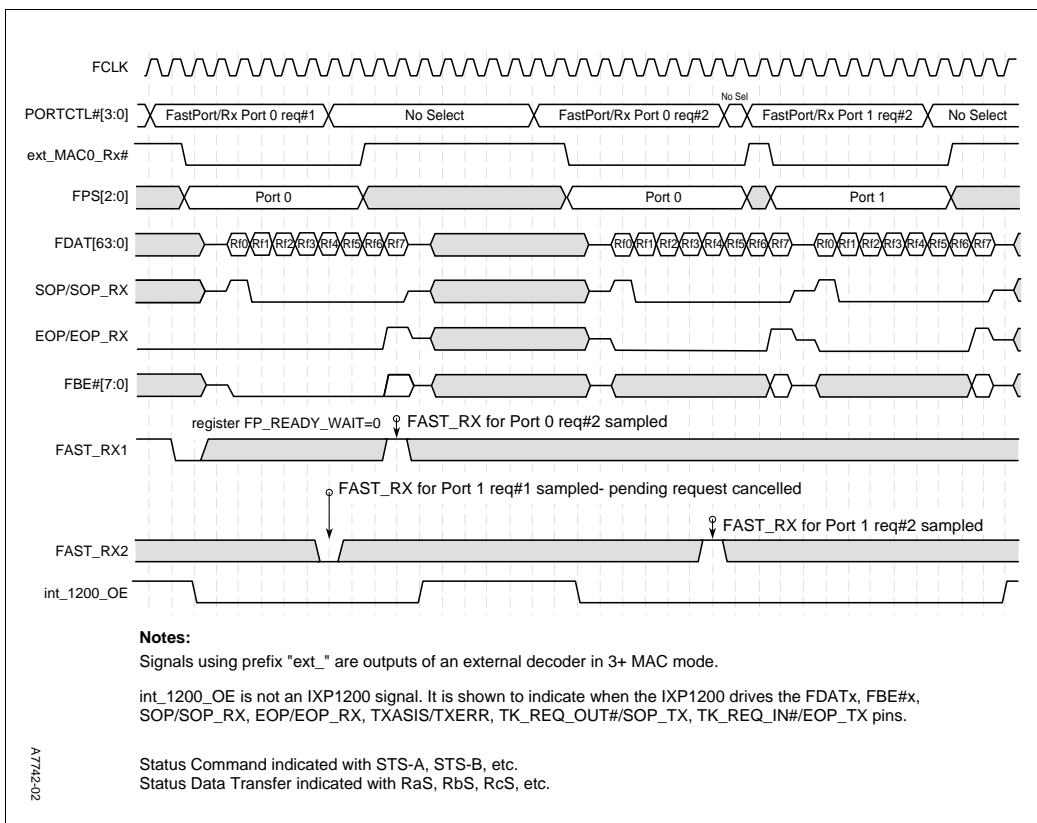
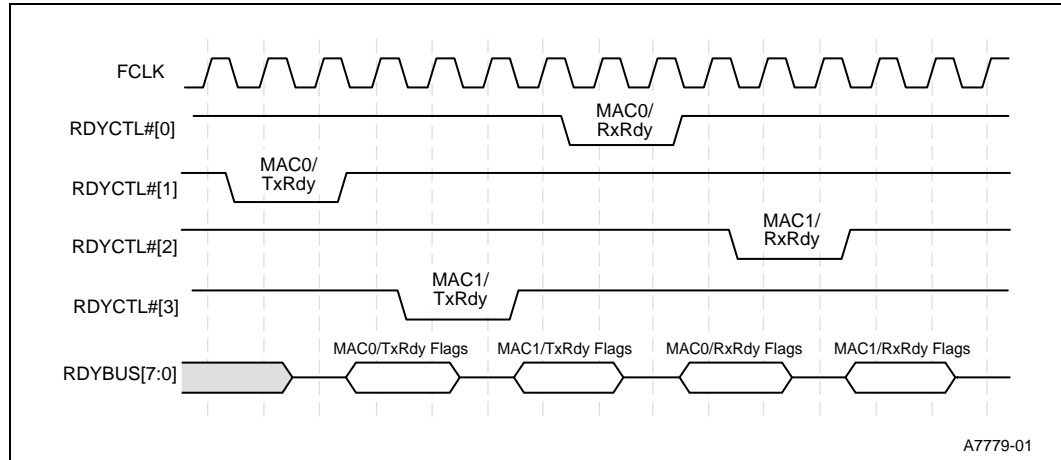

Figure 54. 64-Bit Bidirectional IX Bus Timing - Consecutive FastPort Receives, Different Ports, EOP, No Status, FP\_READY\_WAIT=0, Cancelled Request



### 7.3.7.4 RDYBus

**Figure 55. Consecutive Fetch Ready Flags, 1-2 MAC Mode (with No External Registered Decoder) - RDYBUS\_TEMPLATE\_CTL[10]=1**



**Figure 56. Consecutive Fetch Ready Flags, 3+ MAC Mode (with External Decoder) - RDYBUS\_TEMPLATE\_CTL[10]=0**

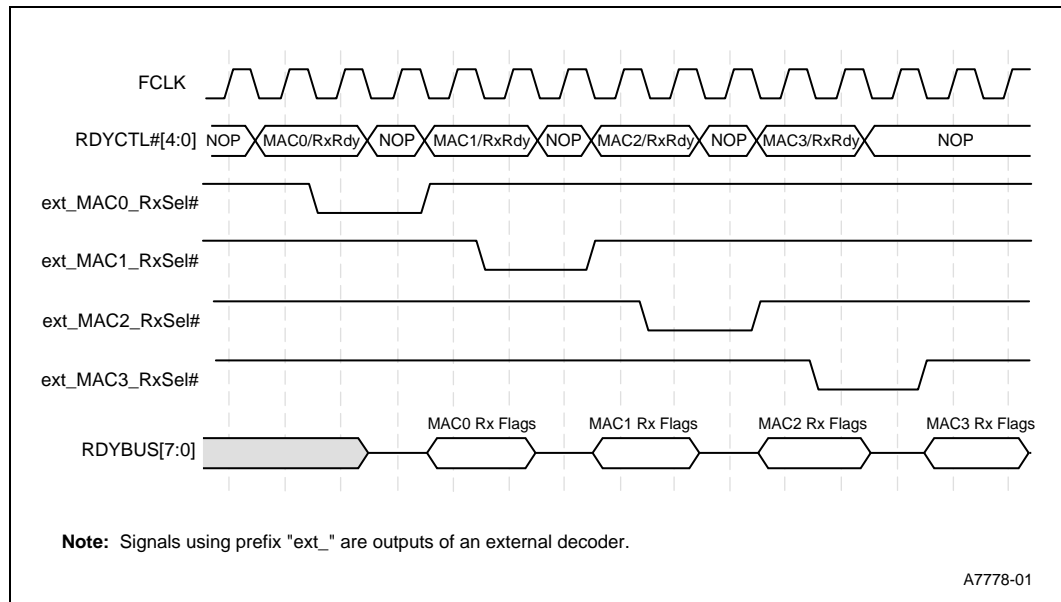

**Figure 57. Fetch Ready Flags, Get/Send Commands, 3+ MAC Mode (with External Registered Decoder) - RDYBUS\_TEMPLATE\_CTL[10]=0**

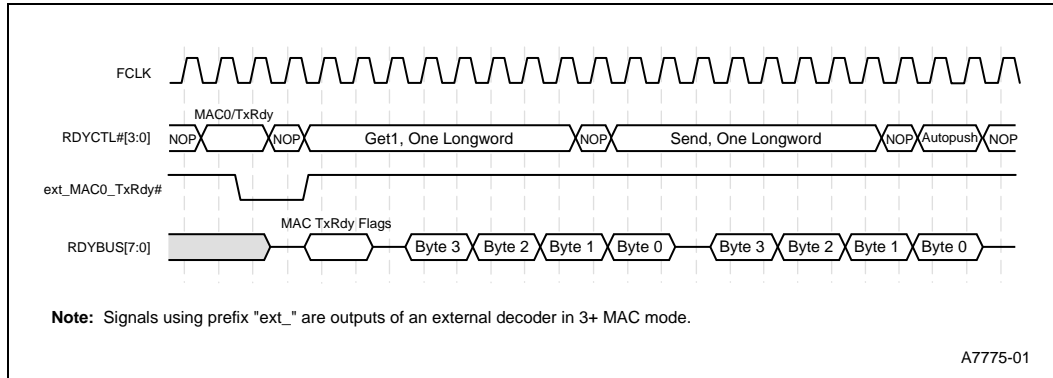

**Figure 58. Ready Bus Control Timing, Fetch Ready Flags - Flow Control - Fetch Ready Flags, 1-2 MAC Mode (with No External Registered Decoder) - RDYBUS\_TEMPLATE\_CTL[10]=1**

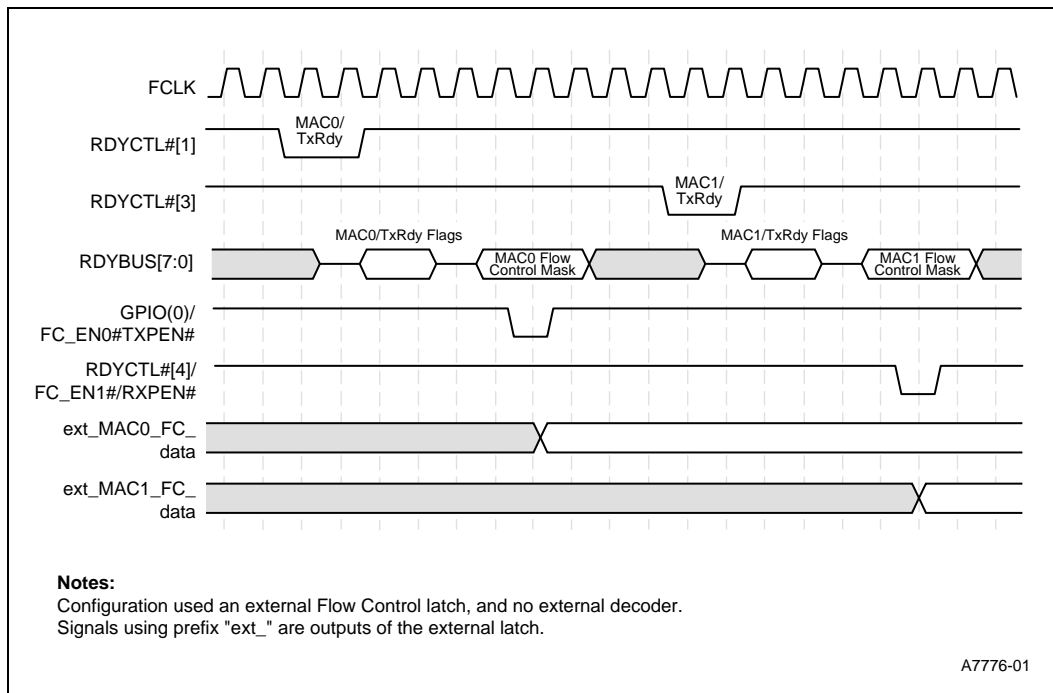

**Figure 59. Ready Bus Control Timing, Fetch Ready Flags - Flow Control - Fetch Ready Flags, 3+ MAC Mode (with External Registered Decoder) - RDYBUS\_TEMPLATE\_CTL[10]=0**

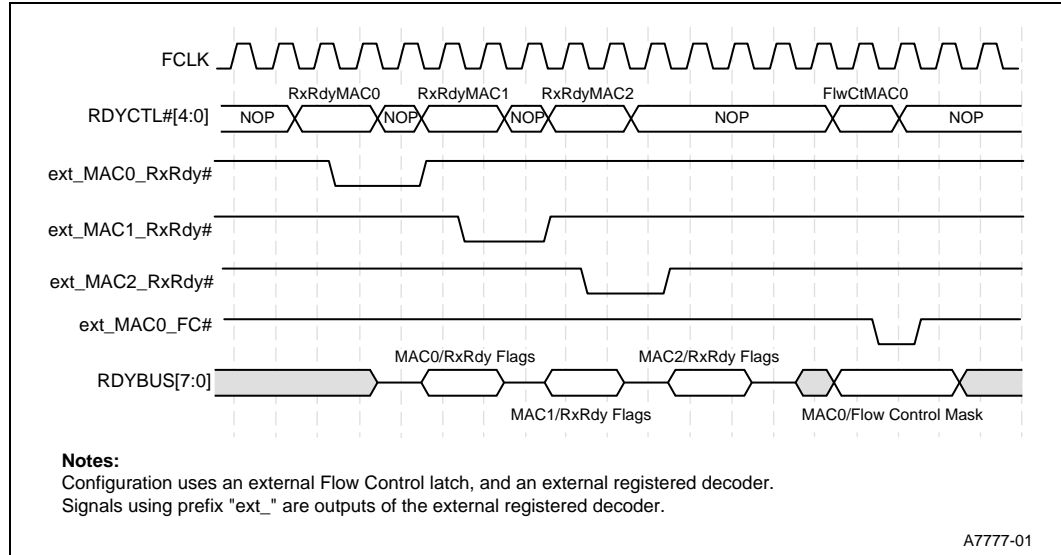

### 7.3.7.5 TK\_IN/TK\_OUT

The following timing diagrams show the transition from one IX Bus owner to another. Note that prior to giving up the bus, the PORTCTL[4:0] signals are driven high which will not select any ports. Then the signal is tri-stated and must be held up with pullup resistors.

Figure 60. IX Bus Ownership Passing

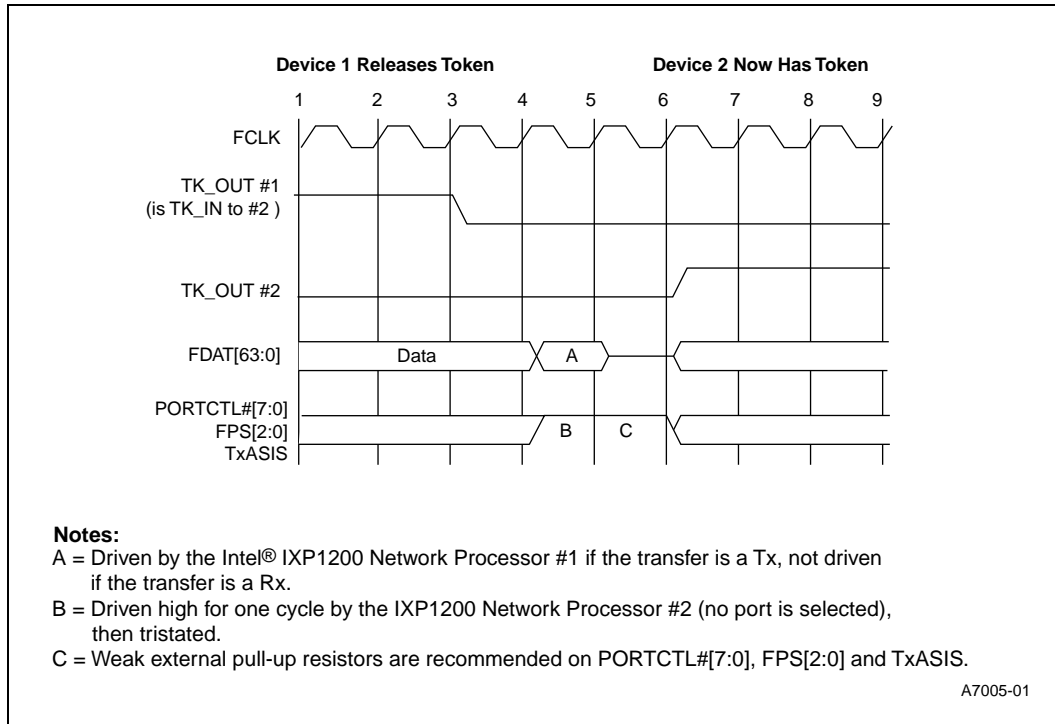

### 7.3.8 SRAM Interface

#### 7.3.8.1 SRAM SCLK Signal AC Parameter Measurements

Figure 61. SRAM SCLK Signal AC Parameter Measurements

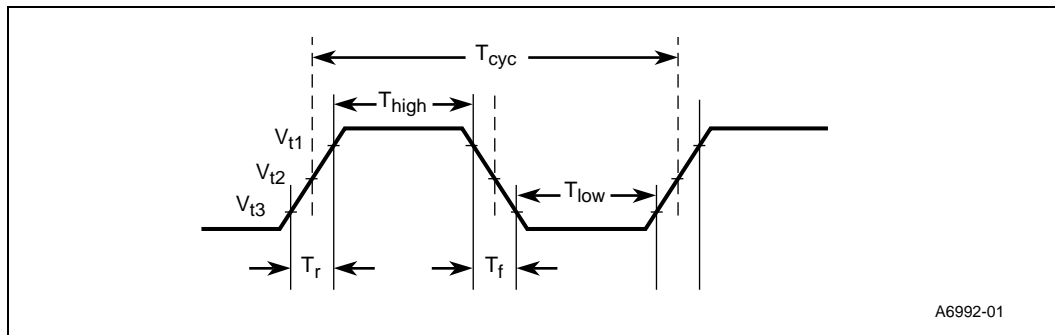

$V_{t1} = 0.5 * V_{DDX}$   
 $V_{t2} = 0.4 * V_{DDX}$   
 $V_{t3} = 0.3 * V_{DDX}$

A6992-01



**Table 47. SRAM SCLK Signal AC Parameter Measurements**

Symbol	Parameter	Minimum (IXP1200 Core Speed)			Maximum (IXP1200 Core Speed)			Unit
		166 MHz	200 MHz	232 MHz	166 MHz	200 MHz	232 MHz	
Freq	Clock frequency	—	—	—	83	100	116	MHz
$T_{cyc}$	Cycle time	12	10	8.62	—	—	—	ns
$T_{high}$	Clock high time	4.02	4	3.3	—	—	—	ns
$T_{low}$	Clock low time	4.02	4	3.3	—	—	—	ns
$T_r, T_f$	SCLK rise/fall time	0.29	0.25	0.21	1.16	1	0.83	ns

### 7.3.8.2 SRAM Bus Signal Timing

Figure 62. SRAM Bus Signal Timing

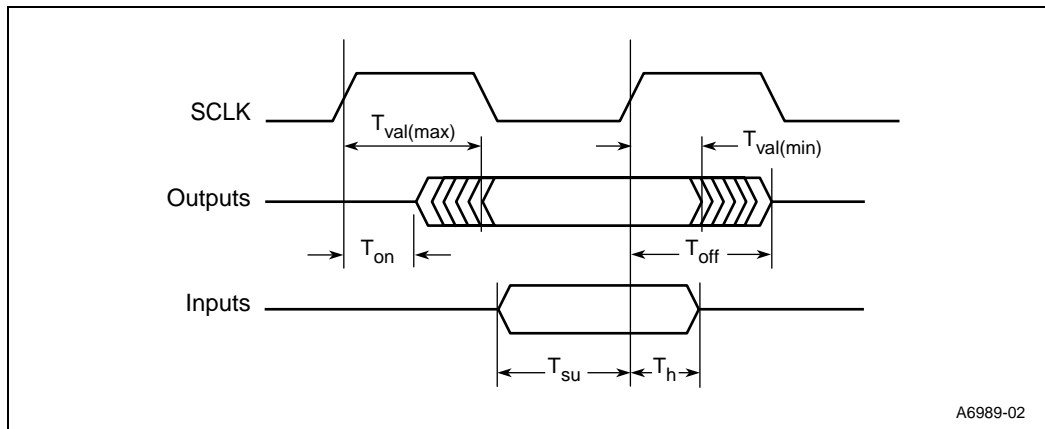

Table 48. SRAM Bus Signal Timing<sup>1,2</sup>

Symbol	Parameter	Minimum (IXP1200 Core Speed)			Maximum (IXP1200 Core Speed)			Unit
		166 MHz	200 MHz	232 MHz	166 MHz	200 MHz	232 MHz	
$T_{val}$	Clock to data output valid delay <sup>3,4</sup>	1.0	1.0	0.5	5.0	4.5	3.35	ns
$T_{ctl}$	Clock to control outputs valid delay <sup>3,4</sup>	1.25	1.0	0.5	5.0	4.5	3.05	ns
$T_{suf}$	Data input setup time before SCLKIN for Flowthru SRAM	2	2	2	---	---	---	ns
$T_{sup}$	Data input setup time before SCLK for Pipelined SRAM <sup>5</sup>	5.5	5.0	3.10	---	---	---	ns
$T_{hf}$	Input signal hold time from SCLKIN for Flowthru SRAM	1	1	1	---	---	---	ns
$T_{hp}$	Input signal hold time from SCLK for Pipelined SRAM	1	1	0.75	---	---	---	ns
$T_{on}^6$	Float-to-active delay from clock	1	1	1	---	---	---	ns
$T_{off}^6$	Active-to-float delay from clock	---	---	---	3	3	3	ns

- Timing parameters assume that the system uses a zero delay clock buffer for SCLK before it is distributed to SRAM.
- When used as a rdy input, HIGH\_EN#/RDY# is asynchronous and can change anywhere relative to SCLK.
- Capacitive loading effects on signal lines are shown in [Table 49](#).
- $T_{val}(\min)$  and 166 MHz and 200 MHz  $T_{ctl}(\min)$  parameters are tested under 0 pF load best case conditions ( $V_{dd}=2.1$ ,  $V_{ddx}=3.6$ ,  $Temp=0$  degrees C) at 1.15 nsec with an uncertainty of 0.25 nsec. The parameter specified is guaranteed by design in a minimally configured system environment.
- Timings are what the tester must measure. Add 0.25 nsec to these numbers to obtain system AC parameter. This additional 0.25 nsec is needed to allow for SRAM drive derating.
- Not tested. Guaranteed by design.

**Table 49. Signal Delay Deratings for  $T_{val}$  and  $T_{ctl}$** 

Signal	Maximum Derating (ns/pF) (IX Bus Speed)			Minimum Derating (ns/pF) (IX Bus Speed)		
	83 MHz	100 MHz	116 MHz	83 MHz	100 MHz	116 MHz
SCLK	0.053	—	—	0.025	—	—
SLOW_EN#	0.065	0.06	0.031	0.03	0.025	0.015
SWE#	0.065	0.06	0.031	0.03	0.025	0.015
SLOW_RD#	0.065	0.06	0.031	0.03	0.025	0.015
SLOW_WE#	0.065	0.06	0.031	0.03	0.025	0.015
SP_CE#	0.065	0.06	0.031	0.03	0.025	0.015
SOE#	0.065	0.06	0.031	0.03	0.025	0.015
HIGH_EN#	0.065	0.06	0.031	0.03	0.025	0.015
LOW_EN#	0.065	0.06	0.031	0.03	0.025	0.015
CE#[3:0]	0.065	0.06	0.031	0.03	0.025	0.015
A[18:0]	0.065	0.06	0.031	0.03	0.025	0.015
DQ[31:0]	0.065	0.06	0.031	0.03	0.025	0.015

### 7.3.8.3 SRAM Bus - SRAM Signal Protocol and Timing

Figure 63. Pipelined SRAM Read Burst of Eight Longwords

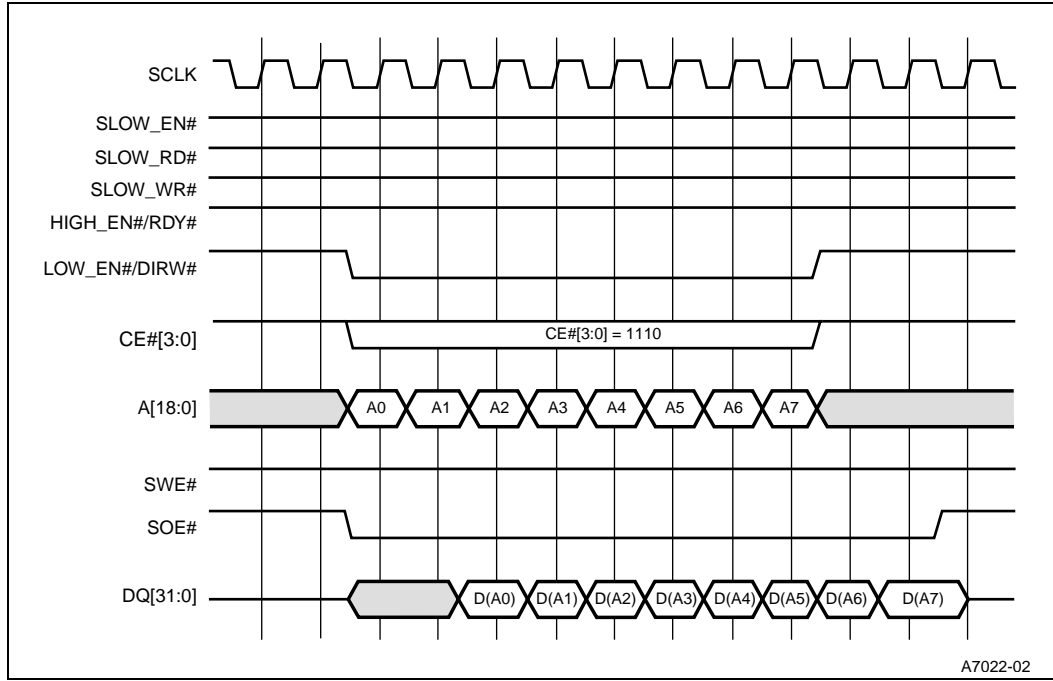
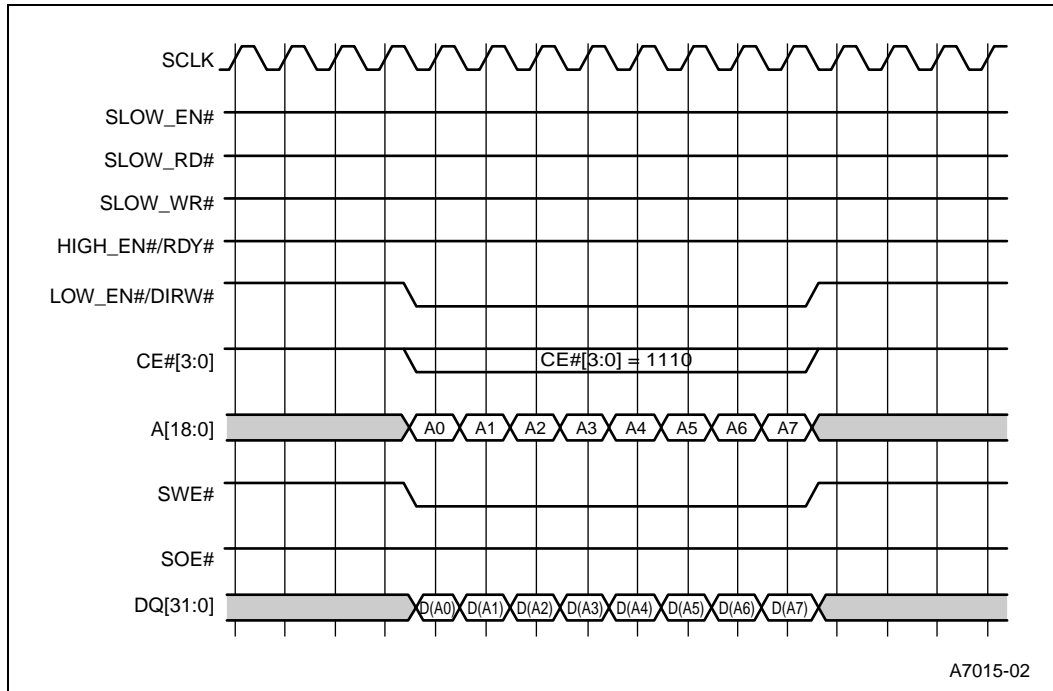
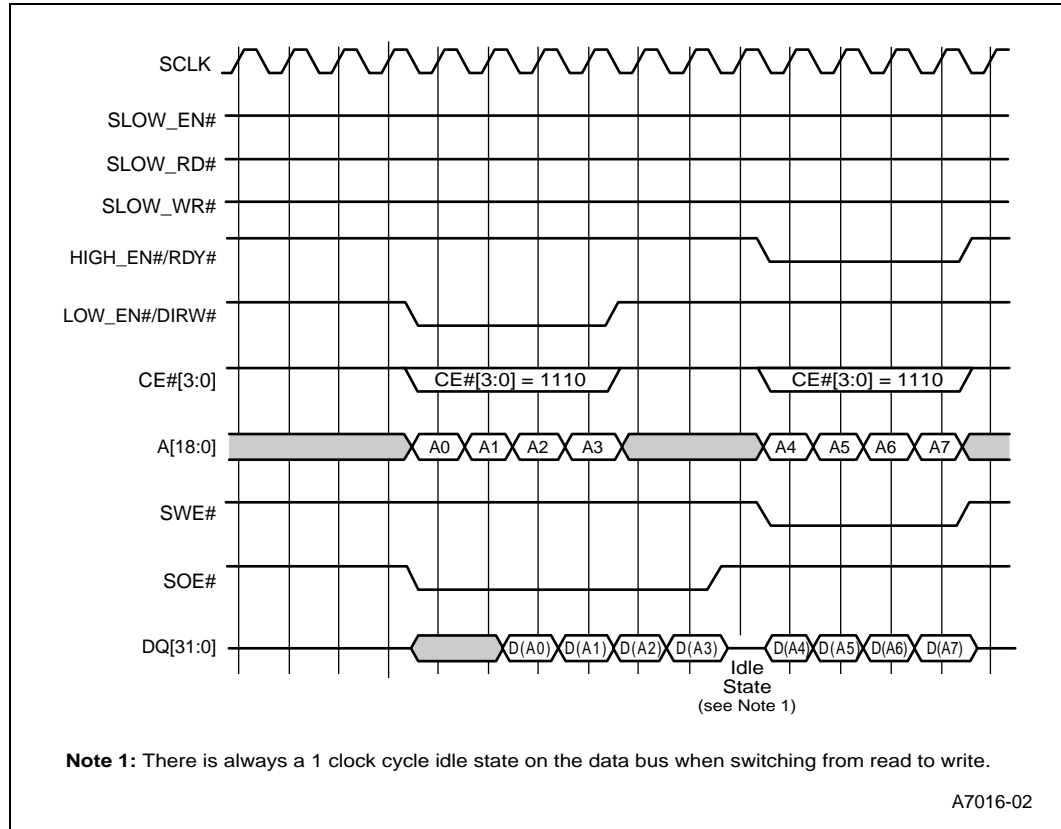

Figure 64. Pipelined SRAM Write Burst of Eight Longwords



**Figure 65. Pipelined SRAM Read Burst of Four From Bank 0 Followed by Write Burst of Four From Bank 8**



**Figure 66. Pipelined SRAM Longword Write Followed by 2 Longword Burst Read Followed by 4 Longword Burst Write**

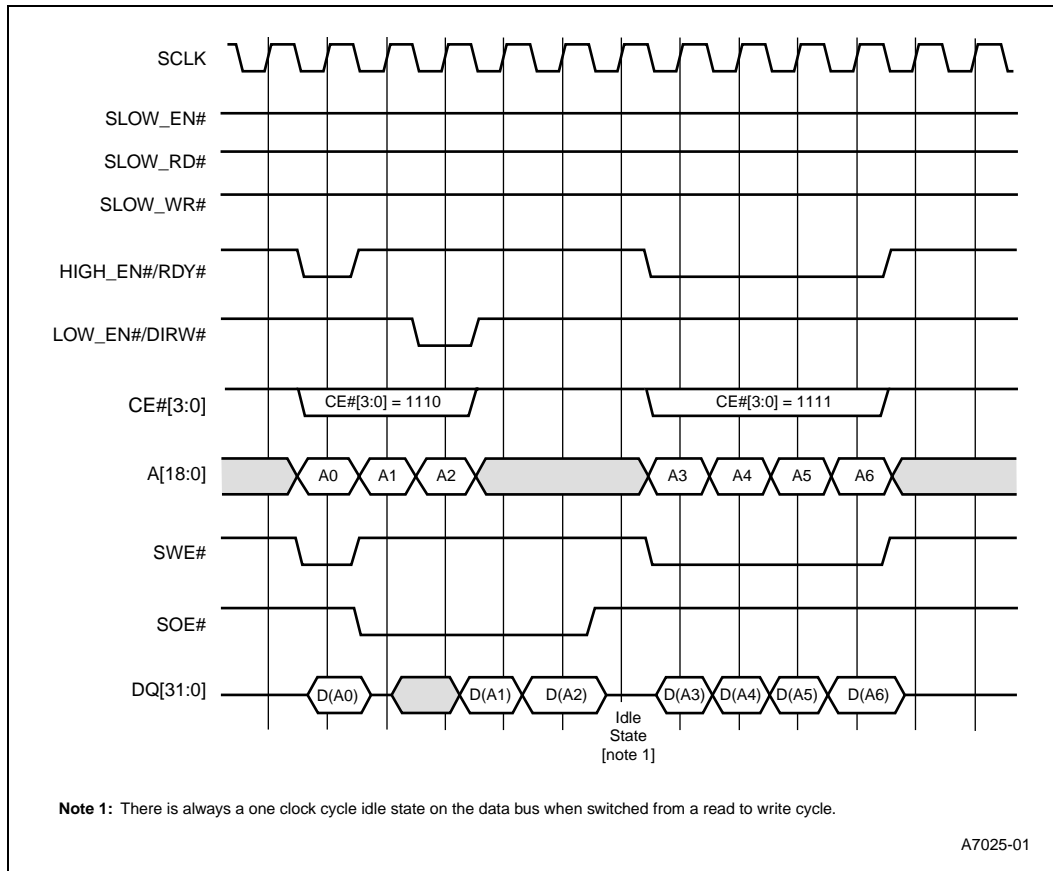
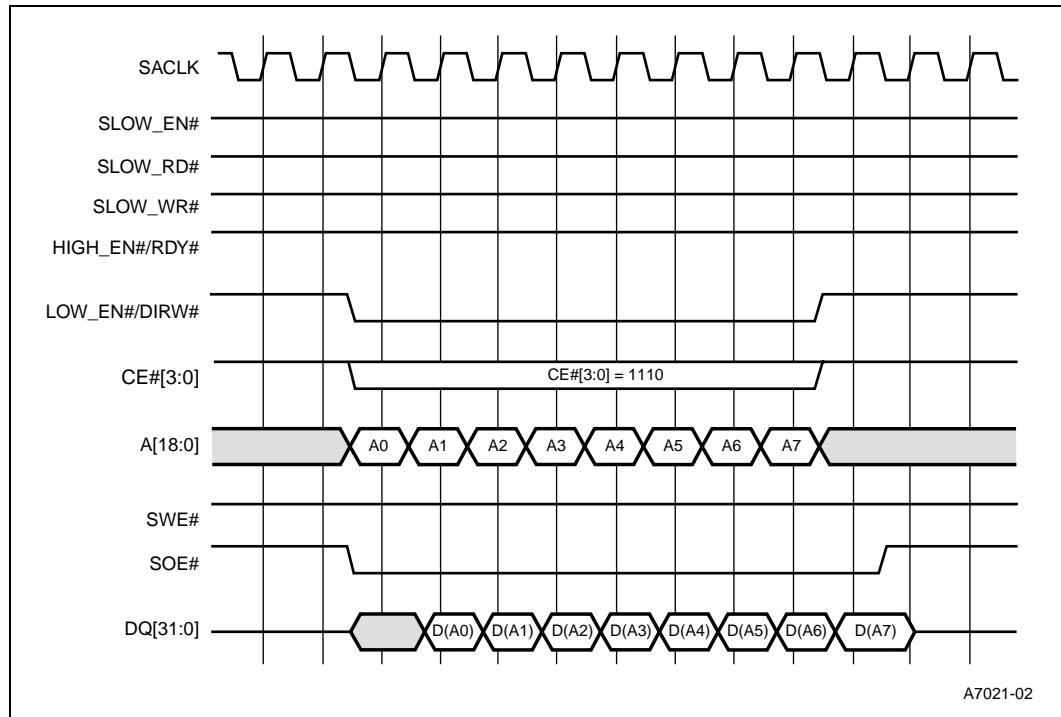

Figure 67. Flowthrough SRAM Read Burst of Eight Longwords



### 7.3.8.4 SRAM Bus - BootROM and SlowPort Timings

Timing for the BootROM and SlowPort areas are programmable through the SRAM configuration registers described in the *IXP1200 Network Processor Family Microcode Programmer's Reference Manual*. The designer should refer to this manual to understand restrictions in selecting timing values. Each timing illustration shows the appropriate register settings to generate the timing shown.

### 7.3.8.5 SRAM Bus - BootRom Signal Protocol and Timing

Figure 68. BootROM Read

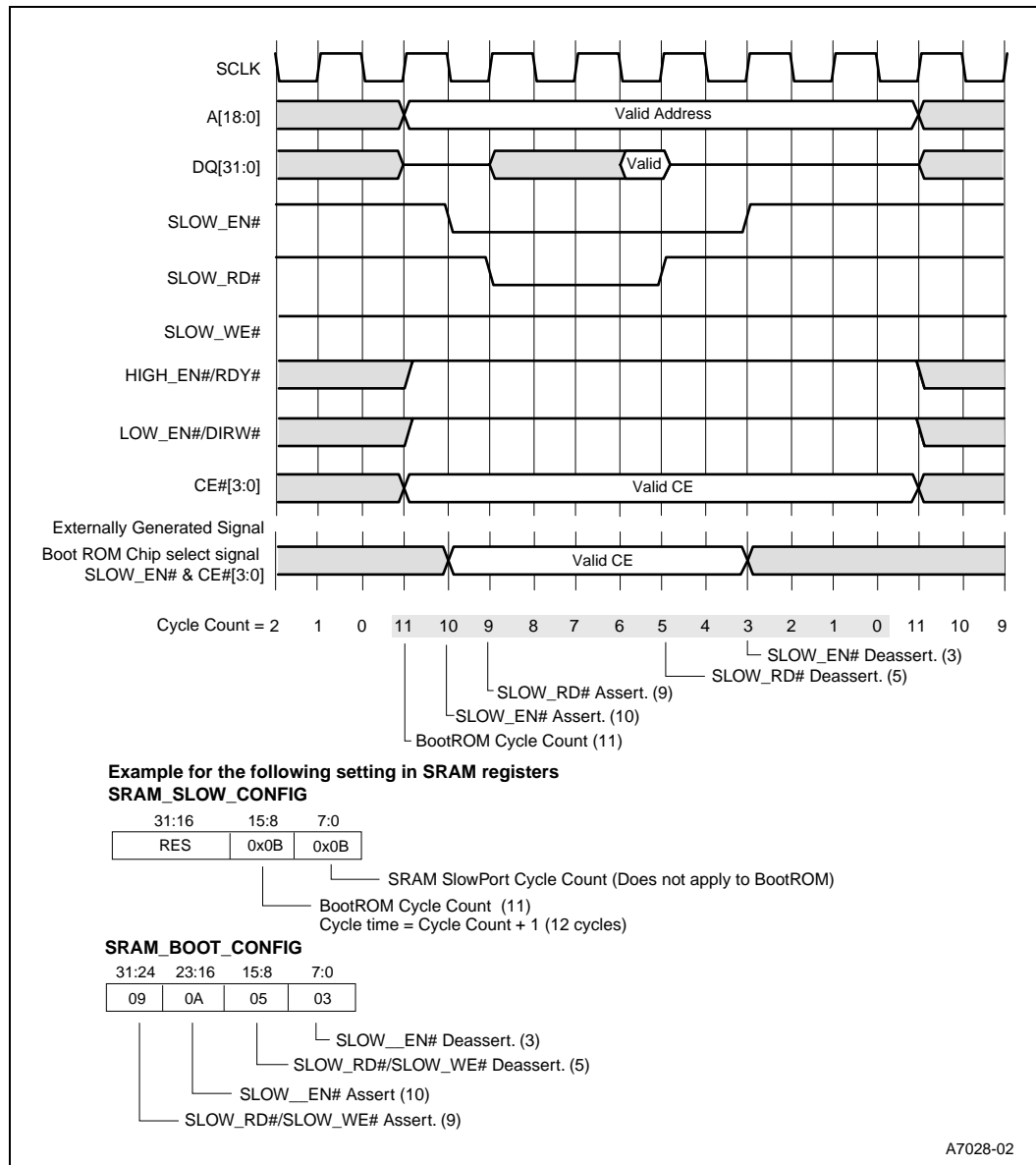



Figure 69. BootROM Write

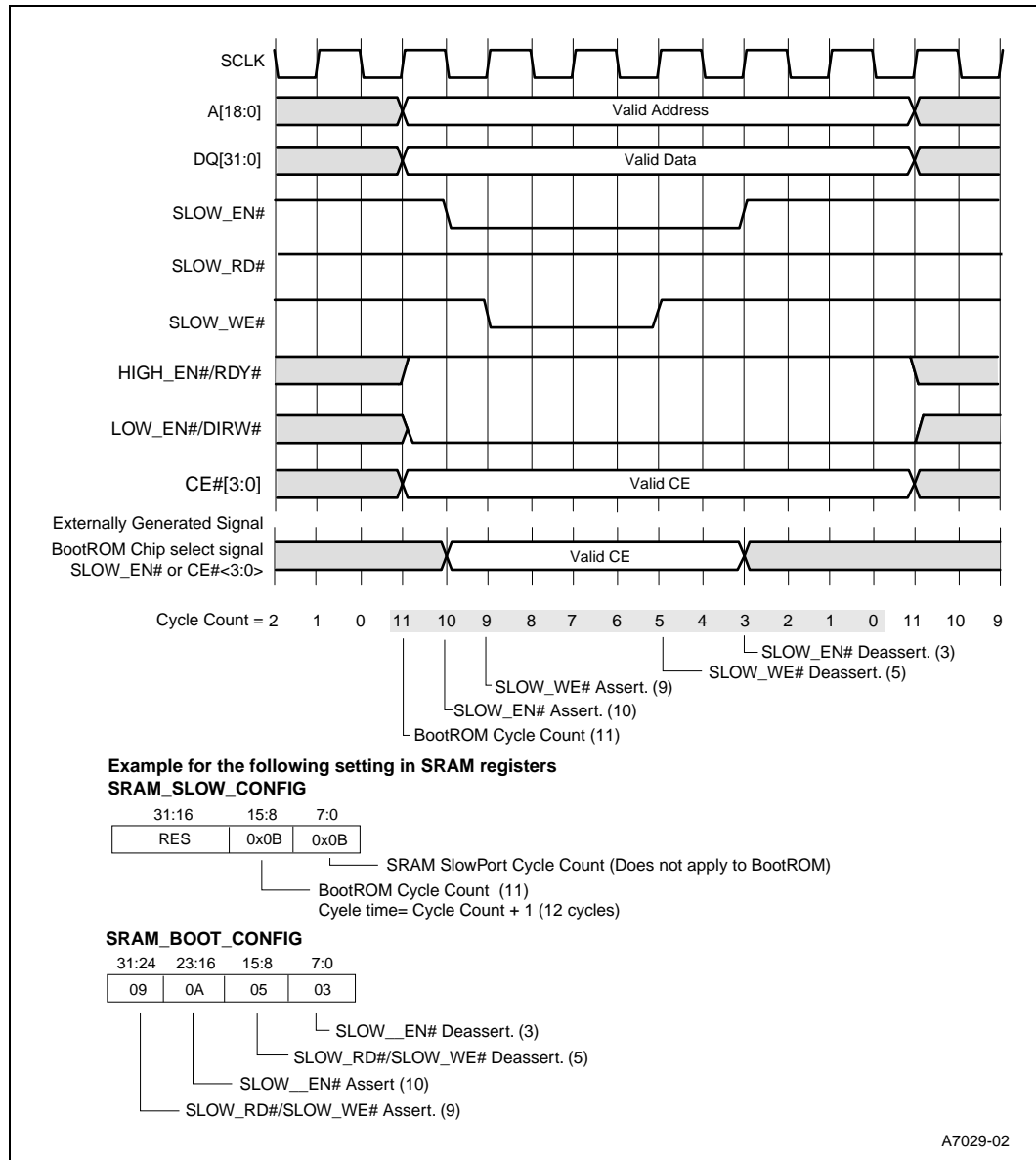
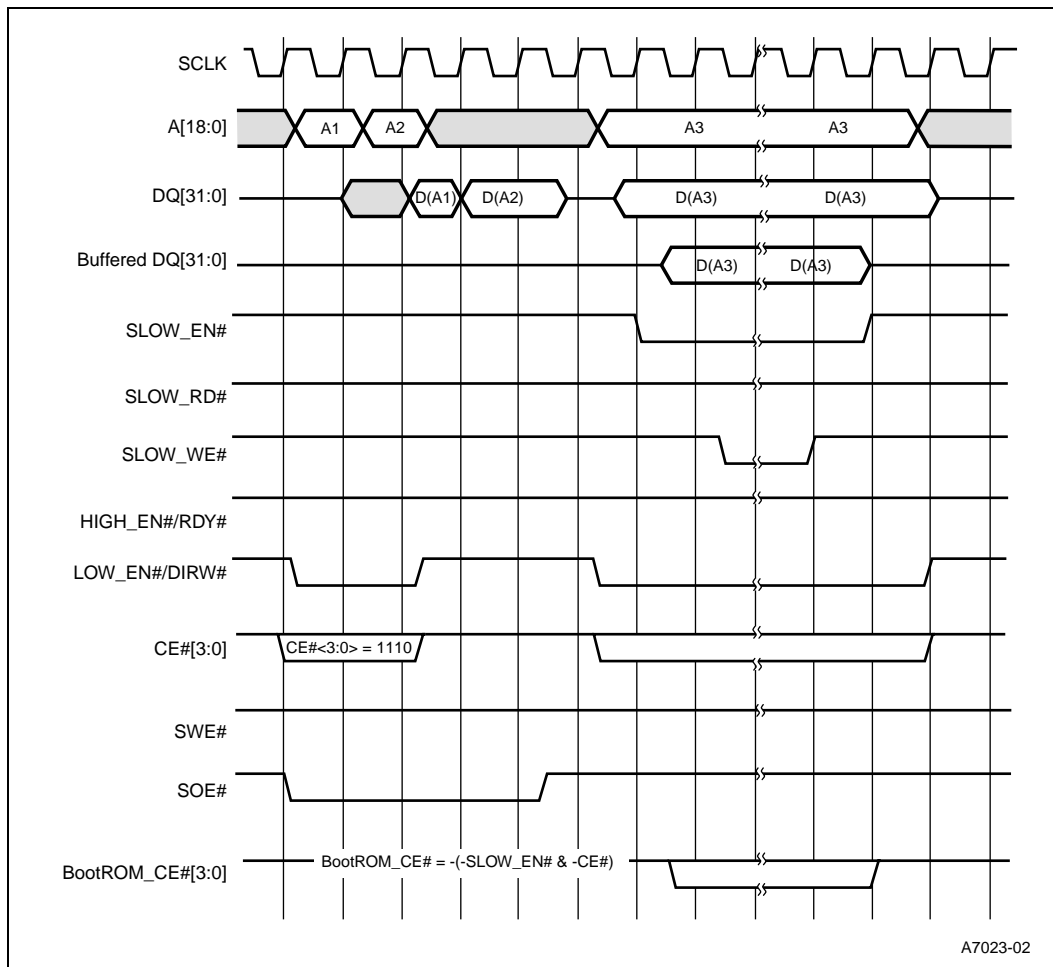

Figure 70. Pipelined SRAM Two Longword Burst Read Followed by BootROM Write



A7023-02

### 7.3.8.6 SRAM Bus - Slow-Port Device Signal Protocol and Timing

Figure 71. SRAM SlowPort Read

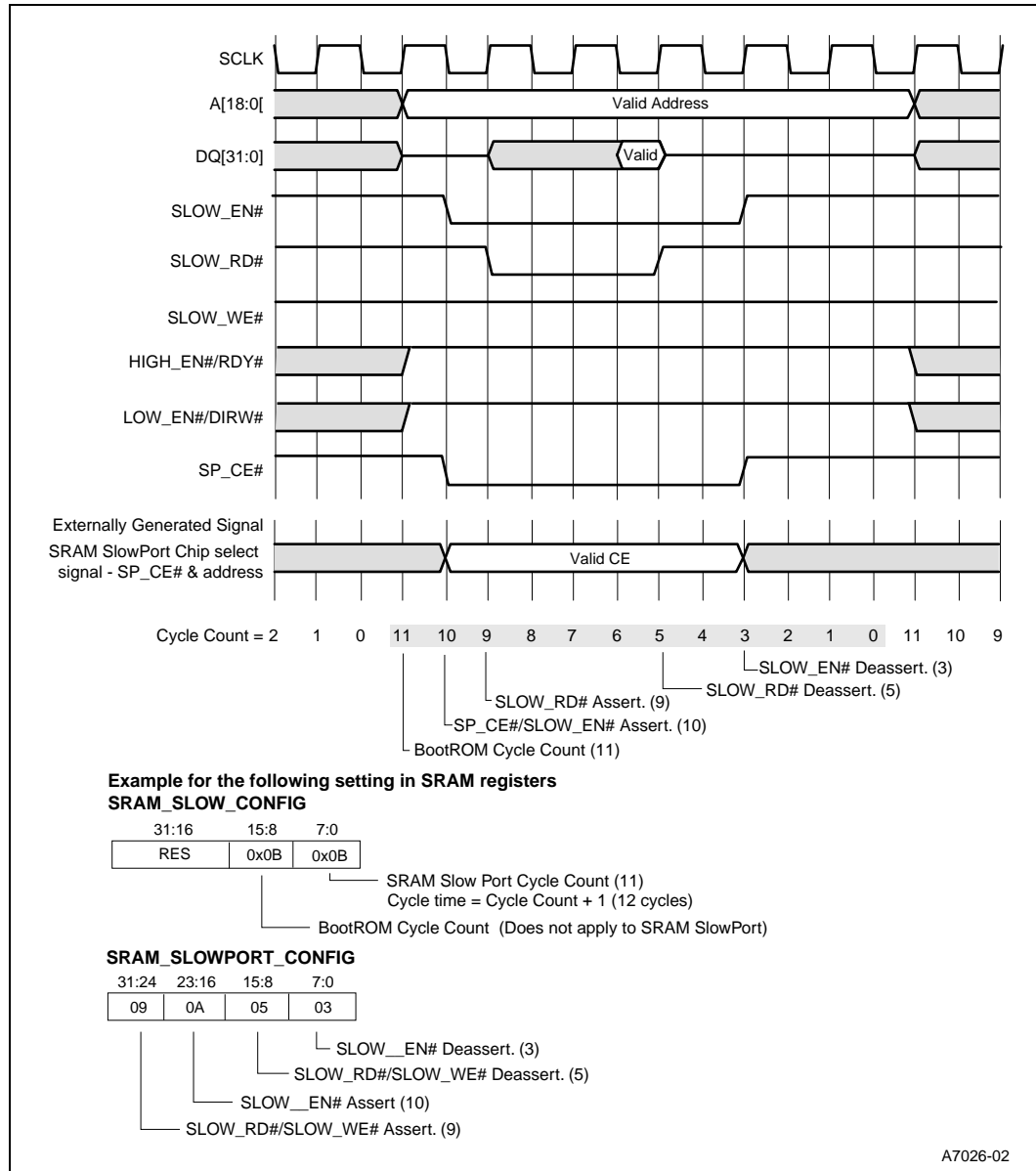

Figure 72. SRAM SlowPort Write

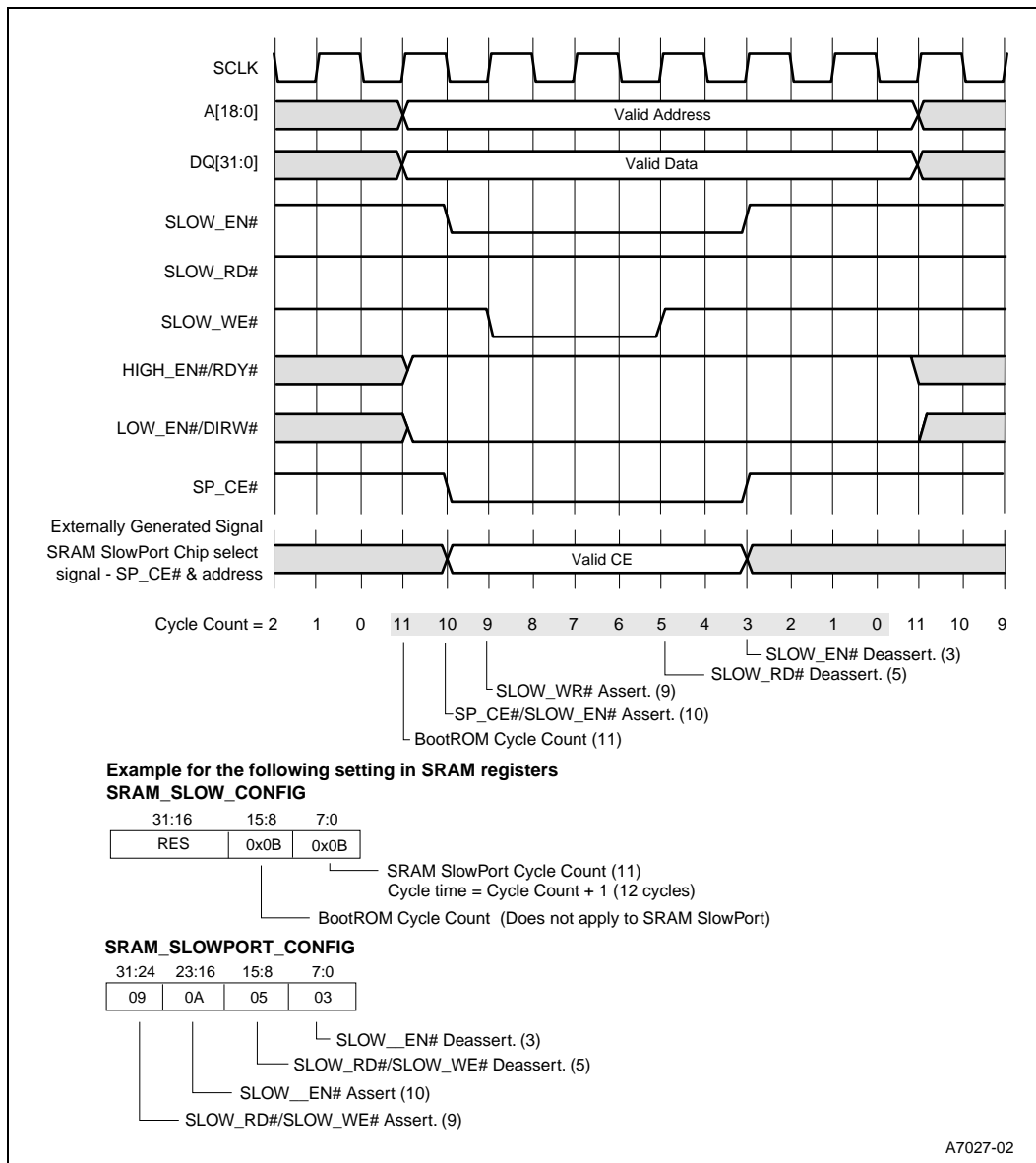

Figure 73. SRAM SlowPort RDY#

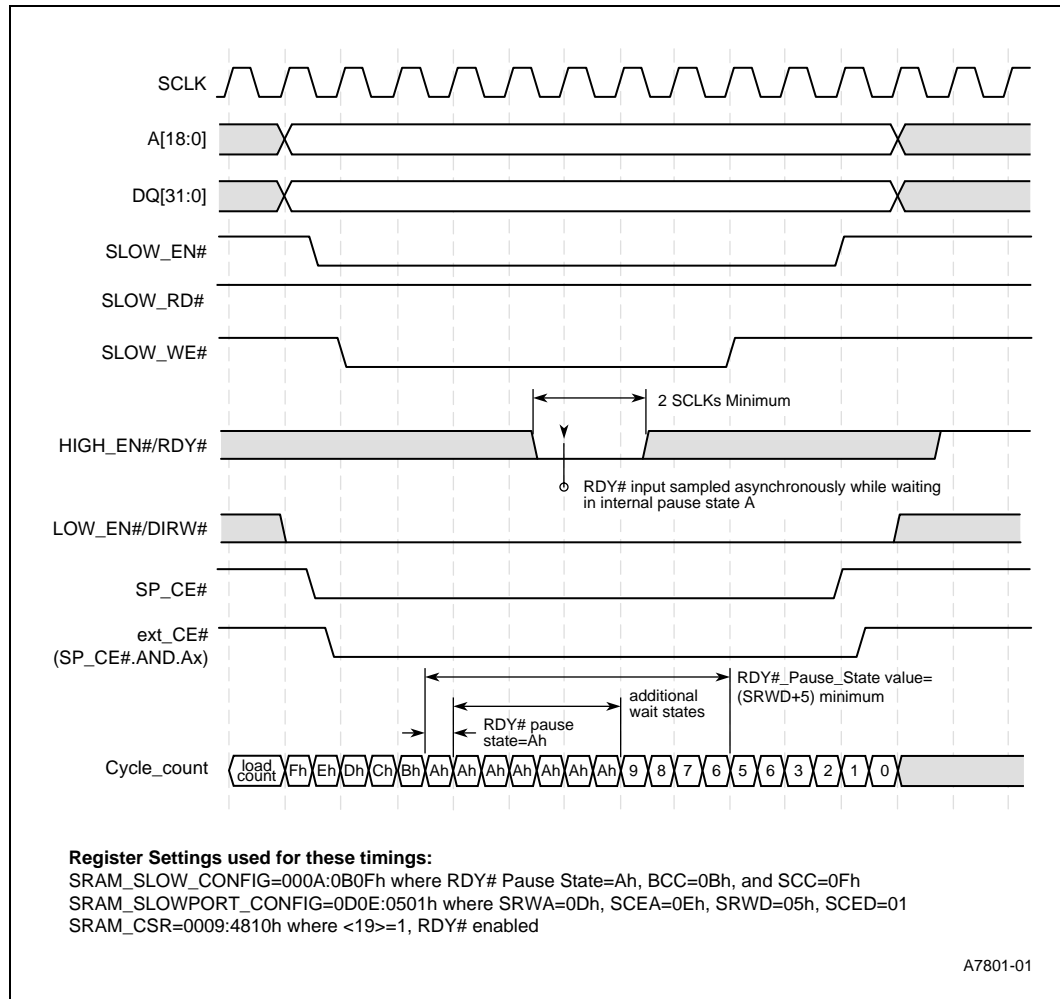
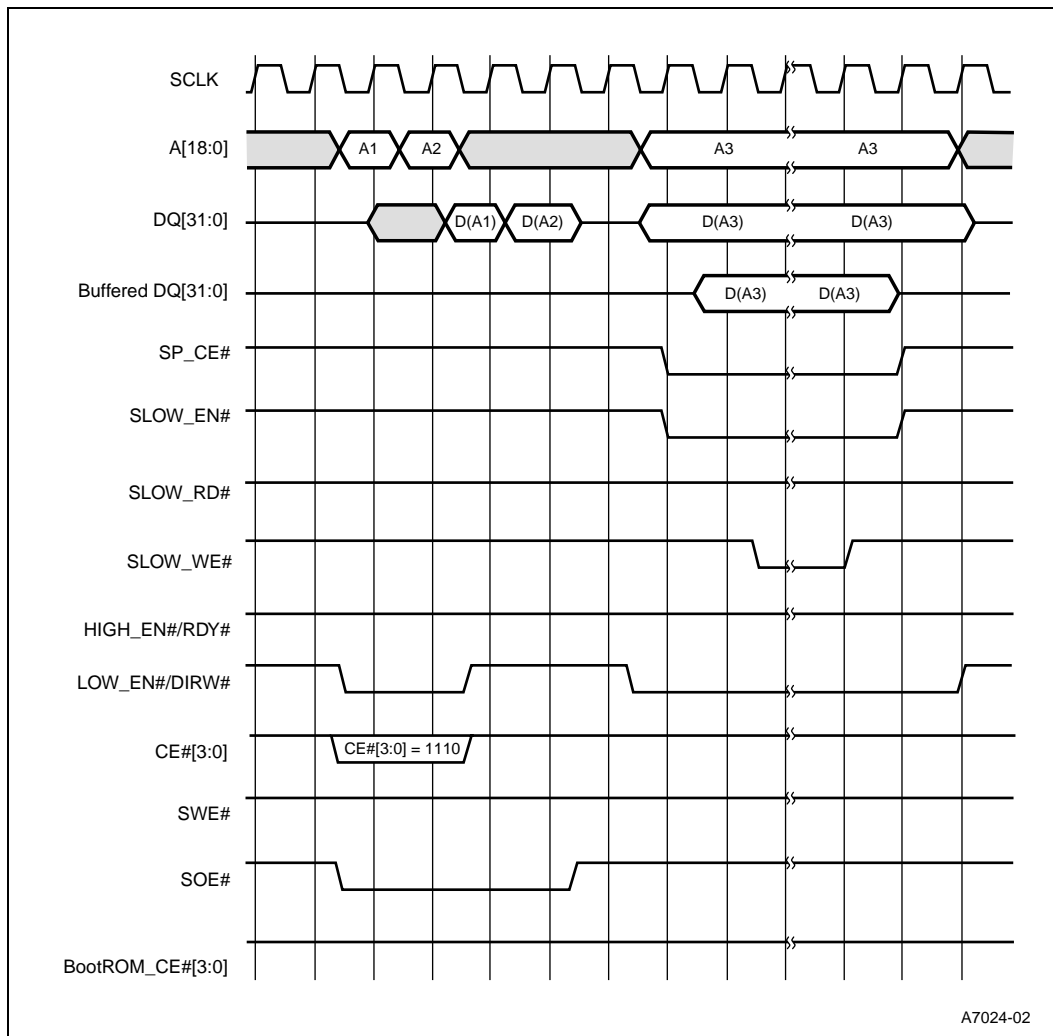

Figure 74. Pipelined SRAM Two Longword Burst Read Followed By SlowPort Write



### 7.3.9 SDRAM Interface

#### 7.3.9.1 SDCLK AC Parameter Measurements

Figure 75. SDCLK AC Timing Diagram

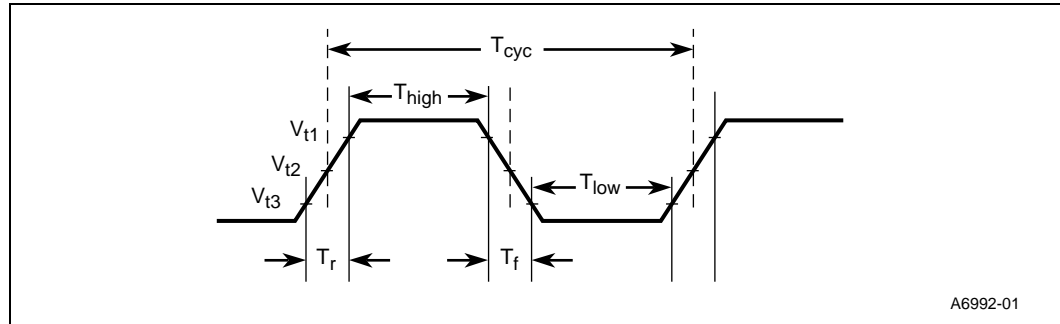

$V_{t1} = 0.5 * V_{DDX}$   
 $V_{t2} = 0.4 * V_{DDX}$   
 $V_{t3} = 0.3 * V_{DDX}$

Table 50. SDCLK AC Parameter Measurements

Symbol	Parameter	Minimum (IXP1200 Core Speed)			Maximum (IXP1200 Core Speed)			Unit
		166 MHz	200 MHz	232 MHz	166 MHz	200 MHz	232 MHz	
Freq	Clock frequency	—	—	—	83	100	116	MHz
$T_{cyc}$	Cycle time	12	10	8.62	—	—	—	ns
$T_{high}$	Clock high time	4.02	4	3.3	—	—	—	ns
$T_{low}$	Clock low time	4.02	4	3.3	—	—	—	ns
$T_r, T_f$	SDCLK rise/fall time	0.29	0.25	0.21	1.16	1	0.83	ns

## 7.3.9.2 SDRAM Bus Signal Timing

Figure 76. SDRAM Bus Signal Timing

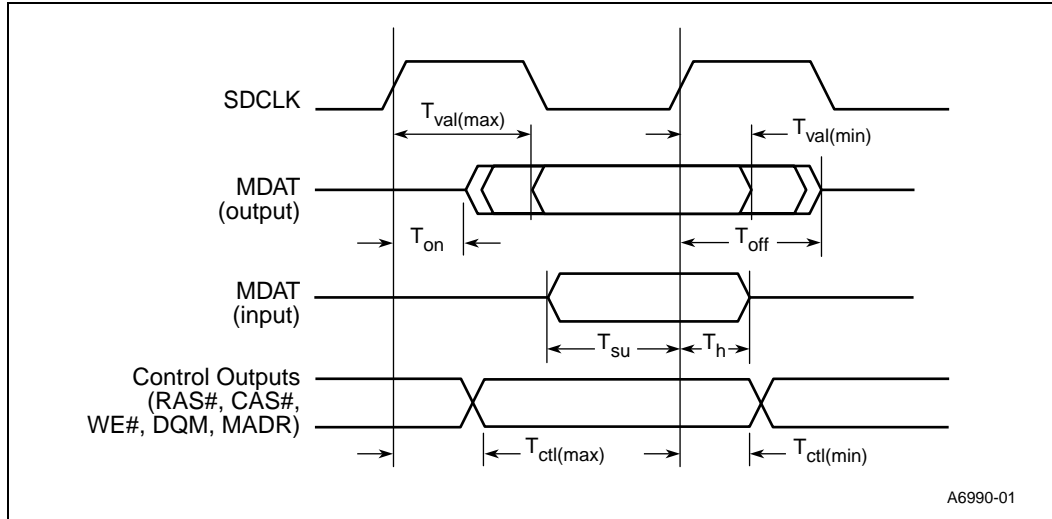
Table 51. SDRAM Bus Signal Timing Parameters<sup>1</sup>

Symbol	Parameter	Minimum (IXP1200 Core Speed)			Maximum (IXP1200 Core Speed)			Unit
		166 MHz	200 MHz	232 MHz	166 MHz	200 MHz	232 MHz	
$T_{val}$	Clock to data output valid delay <sup>2,3</sup>	1.25	1.0	0.5	4.5	4.0	3.3	ns
$T_{ctl}$	SDCLK to control output valid delay <sup>2,3</sup>	1.25	1.0	0.5	4.5	4.0	2.90	ns
$T_{su}$	Data input setup time before SDCLK <sup>4</sup>	4.25	3.70	3.70	---	---	---	ns
$T_h$	Data input hold time from SDCLK	1	1	0.75	---	---	---	ns
$T_{on}^5$	Float to data driven delay from SDCLK	1.25	1	0.75	---	---	---	ns
$T_{off}^5$	Data driven to float delay from SDCLK	---	---	---	3	3	3	ns

- Timing parameters assume that the system uses a zero delay clock buffer for SDCLK before it is distributed to SDRAM.
- Capacitive loading effects on signal lines are shown in Table 52.
- $T_{val(min)}$  and 166 MHz and 200 MHz  $T_{ctl(min)}$  parameters are tested under 0 pF load best case conditions ( $V_{dd}=2.1$ ,  $V_{ddx}=3.6$ ,  $Temp=0$  degrees C) at 1.15 nsec with an uncertainty of 0.25 nsec. The parameter specified is guaranteed by design in a minimally configured system environment.
- Unlike the SRAM setup timing parameter  $T_{sup}$ , the  $T_{su}$  timings are both what the tester must measure and what the SDRAM parts will deliver. Increased performance on the SDRAM bus occurs because the data pins only drive one load.
- Not tested. Guaranteed by design.



Table 52. Signal Delay Deratings for  $T_{val}$  and  $T_{ctl}$ 

Signal	Maximum Derating (ns/pF) (IX Bus Speed)			Minimum Derating (ns/pF) (IX Bus Speed)		
	83 MHz	100 MHz	116 MHz	83 MHz	100 MHz	116 MHz
SDCLK	0.053	—	—	0.025	—	—
DQM	0.065	0.06	0.031	0.03	0.025	0.015
WE#	0.065	0.06	0.031	0.03	0.025	0.015
RAS#	0.065	0.06	0.031	0.03	0.025	0.015
CAS#	0.065	0.06	0.031	0.03	0.025	0.015
MADR[14:0]	0.065	0.06	0.031	0.03	0.025	0.015
MDATA[63:0]	0.095	0.09	0.035	0.03	0.025	0.015

### 7.3.9.3 SDRAM Signal Protocol

This section describes the SDRAM timing parameters referenced in the SDRAM timing diagrams that follow. This nomenclature is consistent with most JEDEC standard SDRAM devices.

#### tRP

tRP is the minimum number of cycles after a precharge cycle that a bank may be opened (or "RASd"). The *IXP1200 Network Processor Family Microcode Programmer's Reference Manual* refers to this as the tRP Precharge Time. Also referred to as "PRECHARGE command period" in SDRAM datasheets.

#### tRASmin

tRASmin is the minimum number of cycles that a bank must be open before it can be closed using a precharge command. The maximum time that a bank may be open, tRASmax, is not checked, because the IXP1200 SDRAM Controller methodology is to close all banks after the usage is complete. The *IXP1200 Network Processor Family Microcode Programmer's Reference Manual* refers to this as the tRASmin Active Command Period. Also referred to as "ACTIVE to PRECHARGE command period" in SDRAM datasheets.

#### tRCD

tRCD is the number of cycles between the bank opening (or "RAS") and any read or write command (or "CAS"). The *IXP1200 Network Processor Family Microcode Programmer's Reference Manual* refers to this as the tRCD RAS to CAS Delay. Also referred to as "ACTIVE to READ or WRITE delay" in SDRAM datasheets.

#### tRRD

tRRD is the number of cycles between successive bank openings, or RAS cycles. The *IXP1200 Network Processor Family Microcode Programmer's Reference Manual* refers to this as the tRRD Bank to Bank Delay Time. Also referred to as "ACTIVE bank A to ACTIVE bank B command" in SDRAM datasheets.

#### tRC

tRC is the SDRAM bank cycle time, indicating that the minimum time that a command may be active. For most cases, this is the sum of tRP and tRASmin, although there are some SDRAM data sheets where the absolute time for tRC (in ns) is not equal to the sum (in ns) of tRP and tRASmin. In these cases, typically when rounding up to an even number of clock cycles, they are equivalent. Since the SDRAM Controller CSRs are programmed with a number of clock cycles, these SDRAMs timing values would appear consistent. tRC is used only to specify the number of cycles between Refresh cycles during initialization of the SDRAM parts. It is possible to eliminate it

altogether, and simply have this time be the sum of  $t_{RP}$  and  $t_{RASmin}$ , as discussed above. The *IXP1200 Network Processor Family Microcode Programmer's Reference Manual* refers to this as the  $t_{RC}$  Bank Cycle Time. Also referred to as "ACTIVE to ACTIVE command period" in SDRAM datasheets.

#### **$t_{DPL}$**

$t_{DPL}$  is the number of cycles after the final data write that a precharge may occur.  $t_{DPL} = 1$  indicates that a precharge may occur on the next cycle. The *IXP1200 Network Processor Family Microcode Programmer's Reference Manual* refers to this as the  $t_{DPL}$  Data In to Precharge Time. Also referred to as "Data-in to PRECHARGE command time" in SDRAM datasheets.

#### **$t_{DQZ}$**

$t_{DQZ}$  indicates the number of cycles of latency after  $DQM$  is seen that the SDRAMs will go into a high-impedance state. For  $t_{DQZ} = 2$ ,  $DQM$  get sampled on the first edge, the SDRAMs get off the bus on the next edge, and the bus may be driven on the third edge. The *IXP1200 Network Processor Family Microcode Programmer's Reference Manual* refers to this as the  $t_{DQZ}$   $DQM$  Data Out Disable Latency. Also referred to as "DQM to data high-impedance during READs" in SDRAM datasheets.

#### **$t_{RWT}$**

Note that for most designs, there may be a requirement to add one or more dead cycles after the SDRAMs get off the bus to avoid possible bus contention on the  $DQM$  bus. This will be a function of the design itself (i.e., component placement, bus loading, the SDRAMs used and  $t_{HZ}$ , the time that it takes for the SDRAM to go to a high-Z state) and the frequency at which the SDRAM interface is running. If extra dead cycles are necessary on a write following read bus turnaround, the  $t_{RWT}$  should be programmed to a non-zero value. If  $t_{RWT}$  is one, then one dead cycle will be added following the completion of a read prior to a write access taking place. The *IXP1200 Network Processor Family Microcode Programmer's Reference Manual* refers to this as the  $t_{RWT}$  Read/write Turnaround Time. Not explicitly specified in SDRAM data sheets, but is a function of memory system design, loading. Most PC100 type SDRAM devices allow a zero-delay read-write turnaround. However,  $t_{HZmax}$  for PC100 devices is 5.4ns (CASL=2) or 7 ns (CASL=3) and  $t_{ON}$  for the IXP1200 is 1 ns, so a 1 clock  $t_{RWT}$  would be required to avoid bus contention.

Figure 77. SDRAM Initialization Sequence

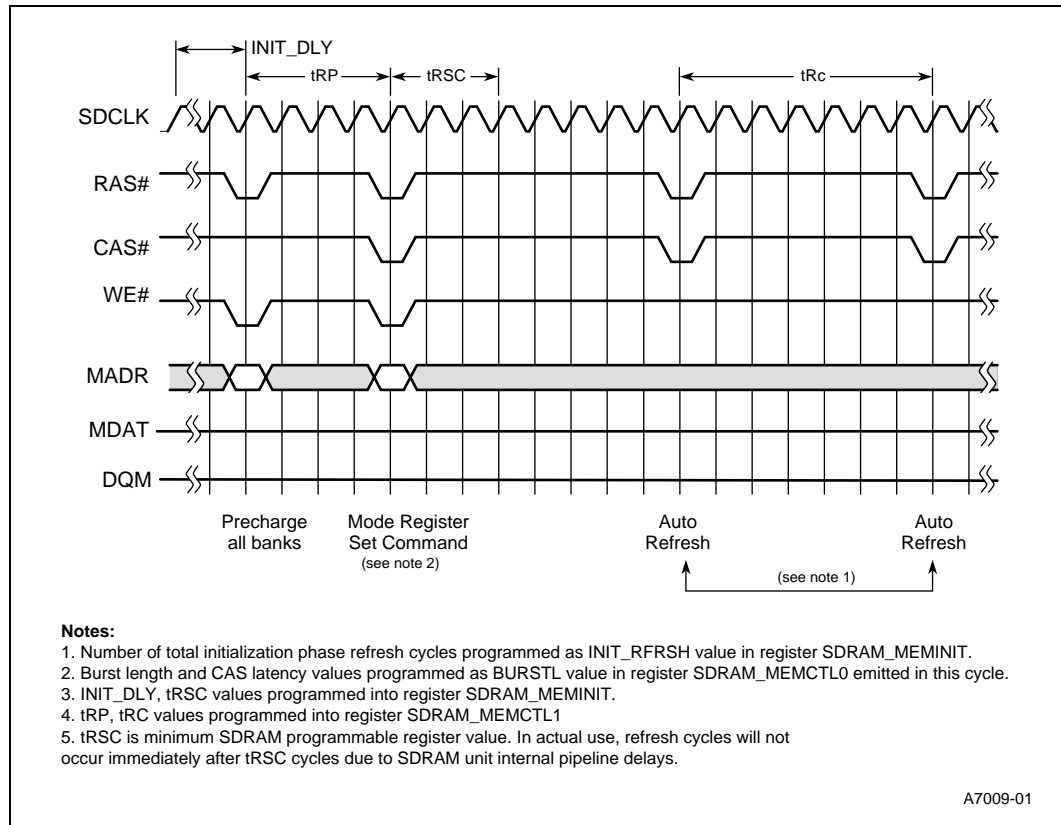

Figure 78. SDRAM Read Cycle

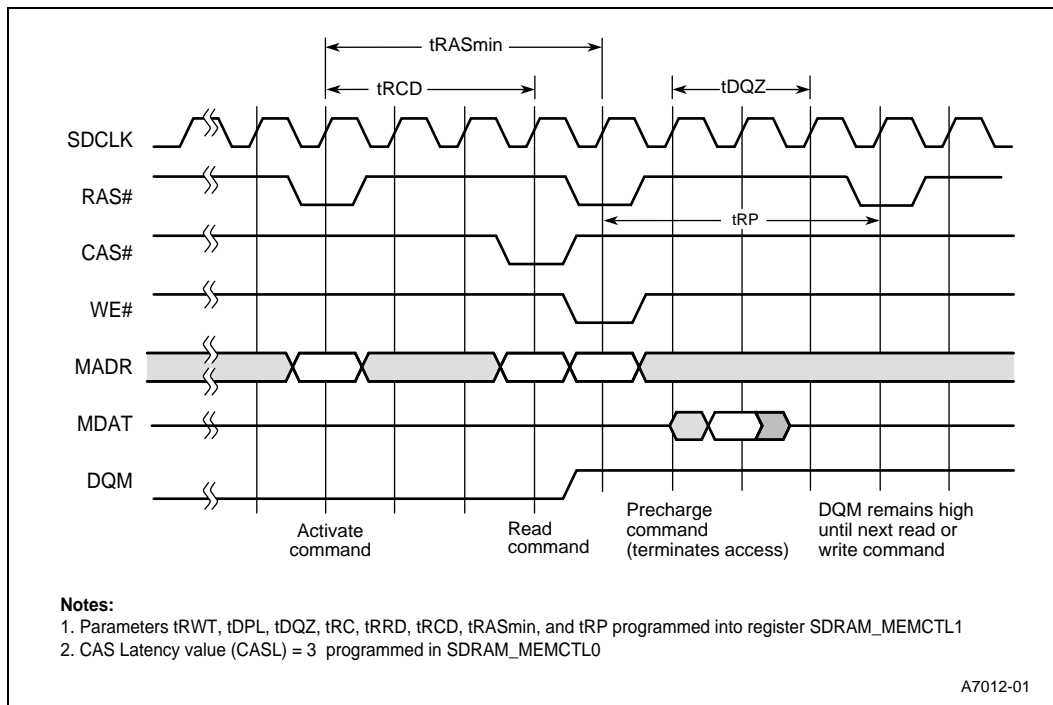

Figure 79. SDRAM Write Cycle

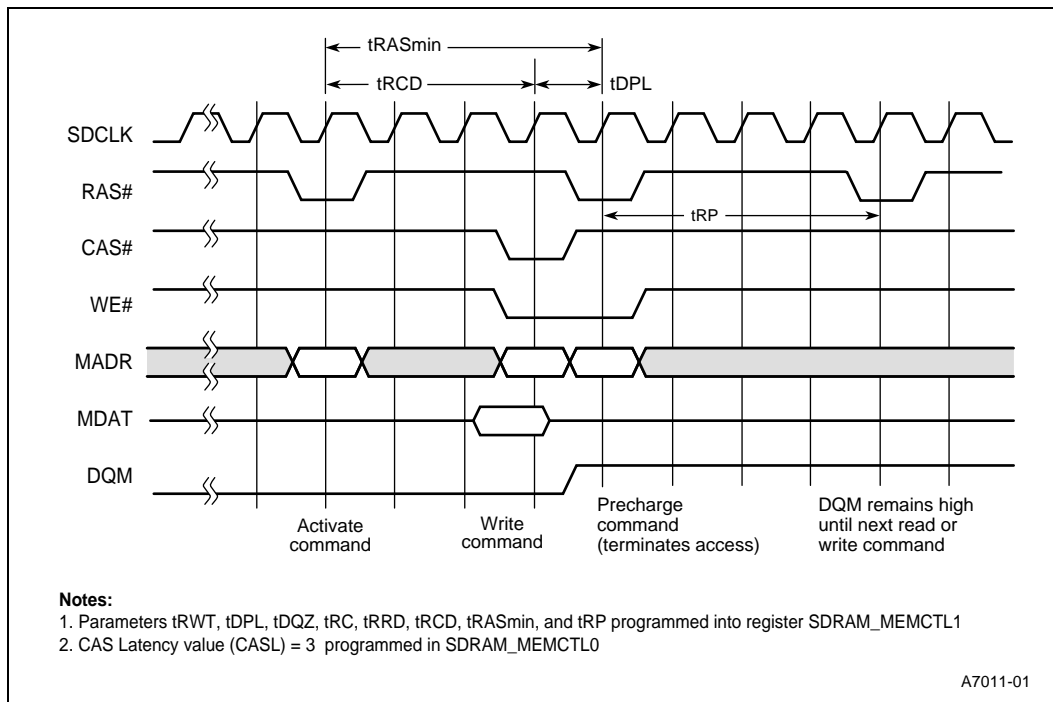
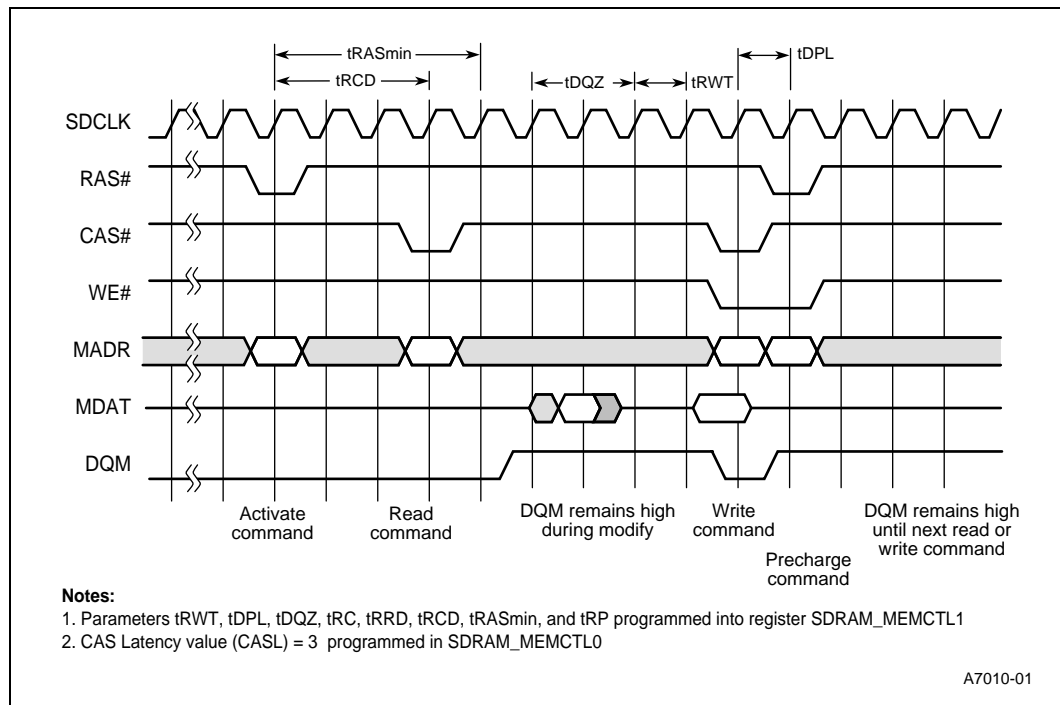

Figure 80. SDRAM Read-Modify-Write Cycle



## 7.4 Asynchronous Signal Timing Descriptions

- RESET\_IN#** Must remain asserted for 150 ms after VDD and VDDX are stable to properly reset the IXP1200.
- RESET\_OUT#** Is asserted for all types of reset (hard, watchdog, and software) and appears on the pin asynchronously to all clocks.
- GPIO[3:0]** Are read and written under software control. When writing a value to these pins, the pins transition approximately 20 ns after the write is performed. When reading these pins, the signal is first synchronized to the internal clock and must be valid for at least 20 ns before it is visible to a processor read.
- TXD, RXD** Are asynchronous relative to any device outside the IXP1200.

## 8.0 Mechanical Specifications

### 8.1 Package Dimensions

The IXP1200 is contained in a 432-HL-PBGA package, as shown in the following illustrations.

**Figure 81. IXP1200 Part Marking**

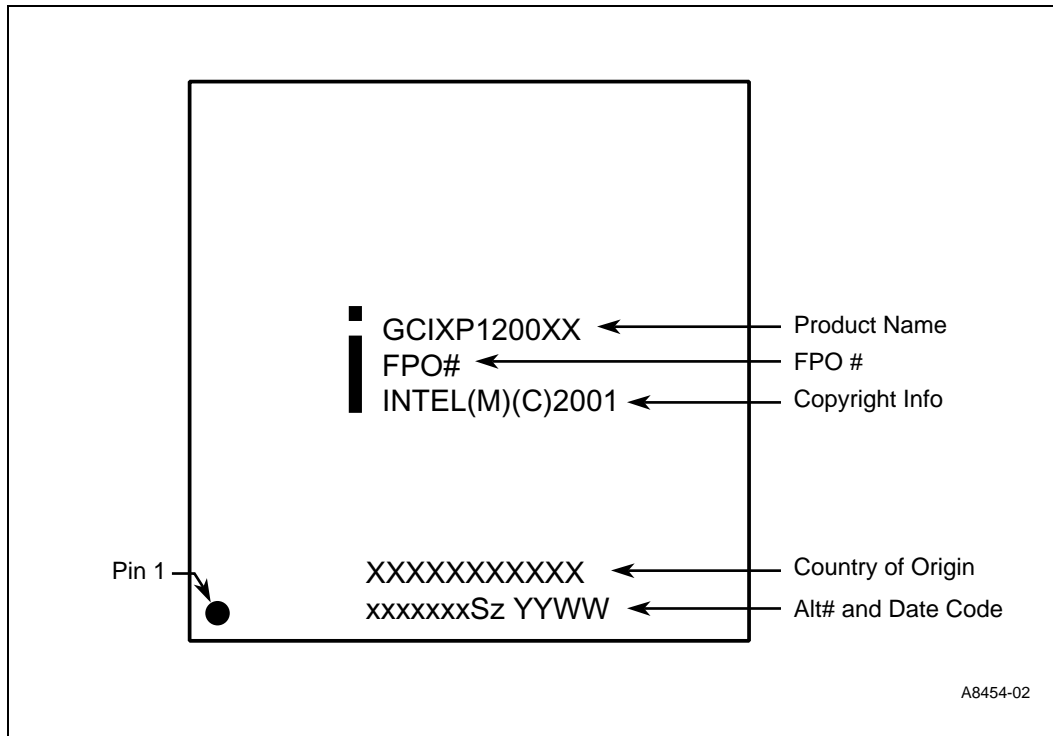

Figure 82. 432-Pin HL-BGA Package - Bottom View

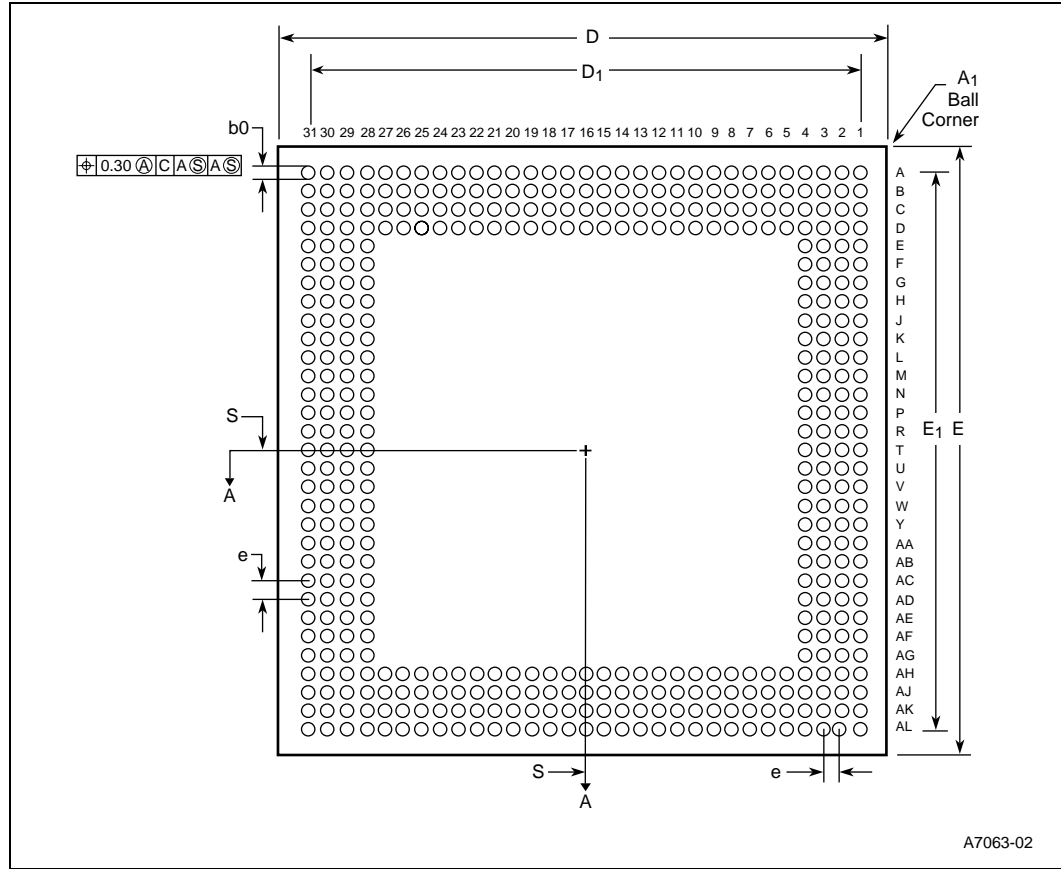

Figure 83. IXP1200 Side View

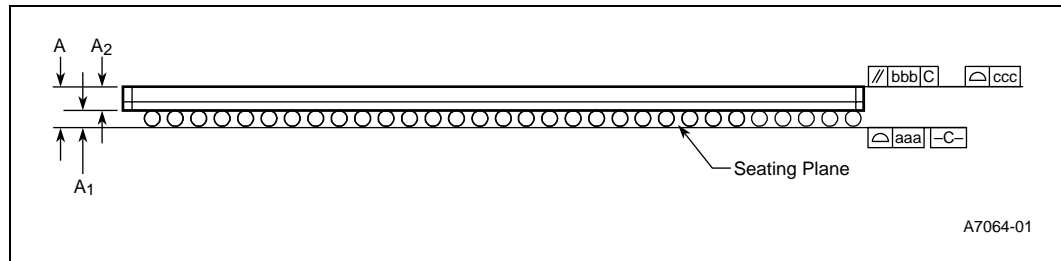
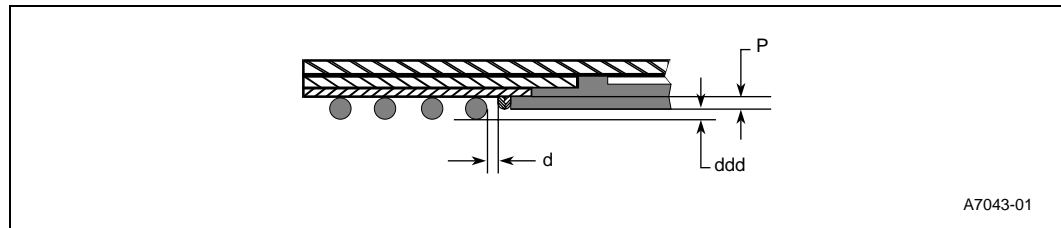

Figure 84. IXP1200 A-A Section View



## 8.2 IXP1200 Package Dimensions (mm)

Table 53. IXP1200 Package Dimensions (mm)

Symbol	Definition	Minimum	Nominal	Maximum
A	Overall thickness	1.41	1.54	1.67
A <sub>1</sub>	Ball height	0.56	0.63	0.70
A <sub>2</sub>	Body thickness	0.85	0.91	0.97
D	Body size	39.90	40.00	40.10
D <sub>1</sub>	Ball footprint	38.00	38.10	38.20
E	Body size	39.90	40.00	40.10
E <sub>1</sub>	Ball footprint	38.00	38.10	38.20
b	Ball diameter	0.60	0.75	0.90
aaa	Coplanarity	--	--	0.20
bbb	Parallel	--	--	0.15
ccc	Top flatness	--	--	0.20
ddd [8]	Seating plane clearance	0.15	0.33	0.50
P	Encapsulation height	0.20	0.30	0.35
S	Solder ball placement	--	--	0.00
M, N	Ball matrix	--	31 x 31	--
M1[7]	Number of rows deep	--	4	--
d	Minimum distance, encap to balls	--	0.6	--
e	Ball pitch	--	1.27	--

**NOTES:**

- All dimensions and tolerances conform to ANSI Y1.45M-1982.
- Dimension "b" is measured at the maximum solder ball diameter parallel to primary datum "c".
- Primary datum "c" and seating plane are defined by the spherical crowns of the solder balls.
- Pin A1 I.D. marked by ink.
- Shape at corner, single form.
- All dimensions are in millimeters.
- Number of rows in from edge to center.
- Height from ball seating plane to plane of encapsulant.
- S is measured with respect to -A- and -B- and defines the position of the center solder ball in the outer row. When there is an odd number of solder balls in the outer row, S=0.000; when there is an even number of solder balls in the outer row, the value S=e/2. S can be either 0.000 or e/2 for each variation.
- The dimension from the outer edge of the resin dam to the edge of the innermost row of the solder ball pads is to be a minimum of 0.50 mm.