



# Celeron<sup>®</sup> Processor Mobile Module: Mobile Module Connector 1 (MMC-1) at 400 MHz, 366 MHz, 333 MHz, and 300 MHz

## Datasheet

### Product Features

- Mobile Celeron<sup>®</sup> Processor with core frequency running at 400 MHz, 366 MHz, 333 MHz, 300 MHz, 266 MHz
- 128K of on-die 2<sup>nd</sup> level cache
- 66-MHz processor system bus speed
- Integrated Active Thermal Feedback (ATF) system
  - ACPI Rev. 1.0 compliant
  - Internal A/D—digital signaling (SMBus) across the module interface
  - Programmable trip point interrupt or poll mode for temperature reading
- Processor core voltage regulation supports input voltages from 5V to 21V
  - Above 80 percent peak efficiency
- Thermal transfer plate on the CPU and the Intel<sup>®</sup> 82433DX for heat dissipation
- Intel 82443DX Host Bridge system controller
  - DRAM controller supports EDO and SDRAM at 3.3V
  - Supports PCI CLKRUN# protocol
  - SDRAM clock support and self refresh of EDO or SDRAM during Suspend mode
  - 3.3V only PCI bus control, *Rev 2.1 compliant*

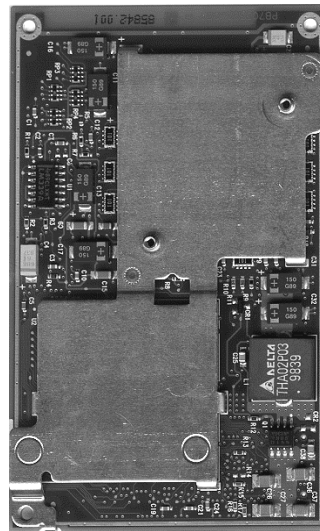

Information in this document is provided solely to enable use of Intel products. Intel assumes no liability whatsoever, including infringement of any patent or copyright, for sale and use of Intel products except as provided in Intel's Terms and Conditions of Sale for such products. Information contained herein supersedes previously published specifications on these devices from Intel.

© INTEL CORPORATION 1999,2000

February 2000

Order Number: 2455426-001

Information in this document is provided in connection with Intel products. No license, express or implied, by estoppel or otherwise, to any intellectual property rights is granted by this document. Except as provided in Intel's Terms and Conditions of Sale for such products, Intel assumes no liability whatsoever, and Intel disclaims any express or implied warranty, relating to sale and/or use of Intel products including liability or warranties relating to fitness for a particular purpose, merchantability, or infringement of any patent, copyright or other intellectual property right. Intel products are not intended for use in medical, life-saving, or life-sustaining applications. Intel may make changes to specifications and product descriptions at any time, without notice.

Designers must not rely on the absence or characteristics of any features or instructions marked "reserved" or "undefined." Intel reserves these for future definition and shall have no responsibility whatsoever for conflicts or incompatibilities arising from future changes to them.

The Celeron processor mobile modules may contain design defects or errors known as errata. Current characterized errata are available on request.

Contact your local Intel sales office or your distributor to obtain the latest specifications and before placing your product order.

Copies of documents which have an ordering number and are referenced in this document, or other Intel literature, may be obtained by calling 1-800-548-4725 or by visiting Intel's web site at <http://www.intel.com>

Copyright © Intel Corporation 1999.

\*Third-party brands and names are the property of their respective owners.

## CONTENTS

1.0	INTRODUCTION.....	5	4.5	Typical POS/STR Power.....	23
1.1	Revision History.....	5	4.6	Electrical Requirements .....	24
2.0	ARCHITECTURE OVERVIEW .....	5	4.6.1	DC Requirements .....	24
3.0	MODULE CONNECTOR INTERFACE.....	7	4.6.2	AC Requirements.....	25
3.1	Signal Definition .....	7	4.6.2.1	BCLK Signal Quality Specifications and Measurement Guidelines .....	26
3.1.1	Signal List.....	8	4.7	The Voltage Regulator .....	26
3.1.2	Memory (108 Signals).....	9	4.7.1	Voltage Regulator Efficiency .....	26
3.1.3	PCI (56 Signals).....	10	4.7.2	Control of the Voltage Regulator.....	27
3.1.4	Processor and PIIIX4E/M Sideband (9 Signals) .....	11	4.7.2.1	Voltage Signal Definition and Sequencing.....	28
3.1.5	Power Management (8 Signals).....	12	4.7.3	Power Planes: Bulk Capacitance Requirements.....	29
3.1.6	Clock (8 Signals).....	13	4.7.4	Surge Current Guidelines .....	30
3.1.7	Voltages (39 Signals).....	14	4.7.4.1	Slew-rate Control: Circuit Description	32
3.1.8	JTAG (7 Signals) .....	14	4.7.4.2	Undervoltage Lockout: Circuit Description (V_uv_lockout).....	33
3.1.9	Miscellaneous (45 Signals).....	15	4.7.4.3	Overvoltage Lockout: Circuit Description (V_ov_lockout).....	34
3.2	Connector Pin Assignments .....	16	4.7.4.4	Overcurrent Protection: Circuit Description.....	34
3.3	Pin and Pad Assignments .....	18	4.8	Active Thermal Feedback .....	34
4.0	FUNCTIONAL DESCRIPTION.....	19	4.9	Thermal Sensor Configuration Register.....	35
4.1	Celeron Processor Mobile Module MMC-1.....	19	5.0	MECHANICAL SPECIFICATION.....	35
4.2	L2 Cache .....	19	5.1	Module Dimensions .....	35
4.3	The 82443DX Host Bridge System Controller.....	19	5.1.1	MMC-1 Connector Pin 1 Location .....	36
4.3.1	Memory Organization .....	19	5.1.2	Printed Circuit Board Thickness.....	36
4.3.2	Reset Strap Options .....	20	5.1.3	Height Restrictions .....	37
4.3.3	PCI Interface.....	20	5.2	Thermal Transfer Plate.....	38
4.3.4	AGP Feature Set.....	20	5.3	Physical Support.....	39
4.4	Power Management.....	20	5.3.1	Mounting Requirements .....	39
4.4.1	Clock Control Architecture .....	20	5.3.2	Module Weight .....	40
4.4.2	Normal State .....	22	6.0	THERMAL SPECIFICATION.....	40
4.4.3	Auto Halt State.....	22	6.1	Thermal Design Power .....	40
4.4.4	Stop Grant State.....	22	6.2	Thermal Sensor Setpoint .....	40
4.4.5	Quick Start State.....	22	7.0	LABELING INFORMATION.....	41
4.4.6	HALT/Grant Snoop State.....	22	8.0	ENVIRONMENTAL STANDARDS .....	42
4.4.7	Sleep State .....	22			
4.4.8	Deep Sleep State.....	23			

## FIGURES

Figure 1. Block Diagram of the Celeron Processor Mobile Module MMC-1 .....	6
Figure 2. 280-Pin Connector Footprint Pad Numbers, Module Secondary Side.....	18
Figure 3. Clock Control States .....	21
Figure 4. BCLK, TCK, and PICCLK Generic Clock Waveform at the Processor Core Pin .....	26
Figure 5. Power-on Sequence Timing.....	29
Figure 6. Instantaneous In-rush Current Model.....	30
Figure 7. Instantaneous In-rush Current.....	31
Figure 8. Over Current Protection Circuit.....	32
Figure 9. Spice Simulation Using In-rush Protection (Example Only) .....	33
Figure 10. Celeron Processor Mobile Module MMC-1 Board Dimensions .....	35
Figure 11. Celeron Processor Mobile Module MMC-1 Board Dimensions- Pin 1 Orientation.....	36
Figure 12. Printed Circuit Board Thickness.....	37
Figure 13. Keep-out Zone.....	37
Figure 14. Thermal Transfer Plate (A) .....	38
Figure 15. Thermal Transfer Plate (B) .....	39
Figure 16. Standoff Holes, Board Edge Clearance, and EMI Containment Ring .....	40
Figure 17. Product Tracking Code .....	41

## TABLES

Table 1. Module Connector Signal Summary.....	7
Table 2. Memory Signal Descriptions .....	9
Table 3. PCI Signal Description .....	10
Table 4. Processor/PIIX4E/M Sideband Signal Descriptions .....	11
Table 5. Power Management Signal Descriptions .....	12
Table 6. Clock Signal Descriptions .....	13
Table 7. Voltage Descriptions .....	14
Table 8. JTAG Pins .....	14
Table 9. Miscellaneous Pins .....	15
Table 10. Connector Pin Assignments.....	16
Table 11. Connector Specifications .....	19
Table 12. Configuration Straps for the 82443DX Host Bridge System Controller .....	20
Table 13. Clock State Characteristics.....	23
Table 14. POS/STR Power.....	23
Table 15. Power Supply Design Specifications .....	24
Table 16. AC Specifications (BCLK) at the Processor Core Pins .....	25
Table 17. BCLK Signal Quality Specifications at the Processor Core .....	26
Table 18. Typical Voltage Regulator Efficiency .....	27
Table 19. Voltage Signal Definitions and Sequences .....	28
Table 20. VR_ON In-rush Current .....	29
Table 21. Capacitance Requirements per Power Plane.....	30
Table 22. Thermal Sensor SMBus Address Table.....	34
Table 23. Thermal Sensor Configuration Register .....	35
Table 24. Thermal Design Power Specifications .....	40
Table 25. Environmental Standards.....	42

## 1.0 INTRODUCTION

This document provides the technical information for integrating the Celeron Processor Mobile Module Connector 1 (MMC-1) into the latest notebook systems for today's notebook market.

Building around this modular design gives the system manufacturer these advantages:

- Avoids complexities associated with designing high-speed processor core logic boards.
- Provides an upgrade path from previous Intel® Mobile Modules using a standard interface.

### 1.1 Revision History

Date	Revision	Updates
3/1999	1.0	Initial release.
5/1999	2.0	<ul style="list-style-type: none"> <li>▪ New 333-MHz processor speed</li> <li>▪ POS/STR corrections</li> <li>▪ ESD clarification</li> <li>▪ VR_ON and VR_PWRGD correction</li> <li>▪ L2 cache correction</li> <li>▪ Power sequence clarification</li> </ul>
6/1999	3.0	New 400-MHz processor speed
2/2000	4.0	Updated Table 22

## 2.0 ARCHITECTURE OVERVIEW

The Celeron processor mobile module MMC-1 is a highly integrated assembly containing the mobile Celeron processor and its immediate system-level support. The Celeron processor mobile module MMC-1 offers speeds of 400 megahertz, 366 megahertz, 333 megahertz, 300 megahertz, and 266 megahertz. All processor speeds have a 66-megahertz processor system bus (PSB) speed.

The PIIX4E/M PCI/ISA Bridge is one of two large-scale integrated devices of the Intel 440DX PCIsset. A notebook's system electronics must include a PIIX4E/M device to connect to the Celeron processor mobile module. The PIIX4E/M provides extensive power management capabilities and supports the second integrated device, the Intel 82443DX Host Bridge. Key features of the Intel 82443DX Host Bridge system controller include the DRAM controller, which supports EDO at 3.3 volts with a burst read at 7-2-2-2 (60 nanoseconds) or SDRAM at 3.3 volts with a burst read at 8-1-1-1 (66 megahertz, CL=2). The 82443DX Host Bridge also regulates the PCI clock on the PCI bus. The 82443DX clock enables Self Refresh mode of EDO or SDRAM during Suspend mode and is compatible with SMRAM (C\_SMRAM) and Extended SMRAM (E\_SMRAM) modes of power management. E\_SMRAM mode supports write-back cacheable SMRAM up to 1 megabyte.

A thermal transfer plate (TTP) on the 82443DX Host Bridge and the CPU provides heat dissipation and a thermal attach point for the notebook manufacturer's thermal solution.

An on-board voltage regulator converts the system DC voltage to the processor's core and I/O voltage. Isolating the processor voltage requirements allows the system manufacturer to incorporate different processor variants into a single notebook system.

Supporting input voltages from 5 volts to 21 volts, the processor core voltage regulator enables an above 80 percent peak efficiency and decouples processor voltage requirements from the system.

The Celeron processor mobile module MMC-1 also incorporates Active Thermal Feedback (ATF) sensing, compliant to the *ACPI Specification Rev 1.0*. A system management bus (SMBus) supports the internal and external temperature sensing with programmable trip points.

Figure 1 illustrates the block diagram of the Celeron processor mobile module MMC-1.

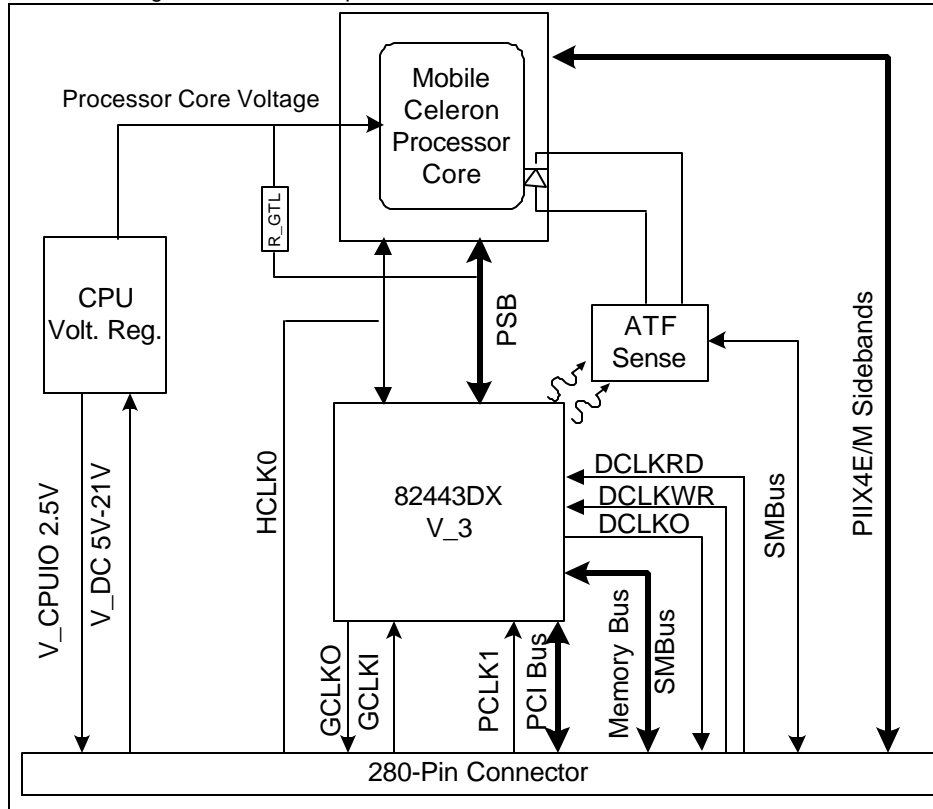

Figure 1. Block Diagram of the Celeron Processor Mobile Module MMC-1

**3.0 CONNECTOR INTERFACE**

This section provides signal group and connector pin information. The signals are defined for compatibility with future Intel mobile modules.

**3.1 Signal Definition**

Table 1 provides a list of signals by category and the corresponding number of signals in each category. For proper signal termination, please contact your Intel sales representative for further information.

**Table 1. Module Connector Signal Summary**

<b>Signal Group</b>	<b>Number of Pins</b>
Memory	108
PCI	56
Processor/PIIX4E/M Sideband	9
Power Management	8
Clocks	8
Voltage: V_DC	10
Voltage: V_3S	20
Voltage: V_5	1
Voltage: V_3	5
Voltage: V_CPUIO	3
JTAG	7
Miscellaneous and Module ID	5
Ground	32
Reserved	8
Total	280

### 3.1.1 Signal List

The following notations are used to denote the signal type:

I	Input pin
O	Output pin
O D	Open-drain output pin requiring a pullup resistor
I D	Open-drain input pin requiring a pullup resistor
I/O D	Input/Open-drain output pin, this pin requires a pullup resistor
I/O	Bi-directional input/output pin

The signal description also includes the type of buffer used for a particular signal:

GTL+	Open-drain GTL+ interface signal
PCI	PCI bus interface signals
CMOS	The CMOS buffers are low voltage TTL compatible signals with 3.3-volt outputs and 5.0-volt tolerant inputs.



### 3.1.2 Memory (108 Signals)

Table 2 lists the memory interface signals.

Table 2. Memory Signal Descriptions

Name	Type	Voltage	Description
MECC[7:0]	I/O CMOS	V <sub>3</sub>	<b>Memory ECC Data:</b> These signals carry Memory ECC data during access to DRAM. <i>ECC is not supported on the Celeron processor mobile module.</i>
RASA[5:0]# or CSA[5:0]#	O CMOS	V <sub>3</sub>	<b>Row Address Strobe (EDO):</b> These pins select the DRAM row. <b>Chip Select (SDRAM):</b> These pins activate the SDRAMs. SDRAM accepts any command when its CS# pin is active low.
CASA[7:0]# or DQMA[7:0]	O CMOS	V <sub>3</sub>	<b>Column Address Strobe (EDO):</b> These pins select the DRAM column. <b>Input/Output Data Mask (SDRAM):</b> These pins act as synchronized output enables during a read cycle and as a byte mask during a write cycle.
MAB[9:0]# MAB[10] MAB[12:11]# MAB[13]	O CMOS	V <sub>3</sub>	<b>Memory Address (EDO/SDRAM):</b> This is the row and column address for DRAM. The 82443DX Host Bridge system controller has two identical sets of address lines (MAA and MAB#). The Celeron processor mobile module MMC-1 supports only the MAB set of address lines. For additional addressing features, please refer to the <i>Intel® 440DX PC/SET Datasheet</i> .
MWE[A, B]#	O CMOS	V <sub>3</sub>	<b>Memory Write Enable (EDO/SDRAM):</b> MWEA# should be used as the write enable for the memory data bus.
SRAS[A, B]#	O CMOS	V <sub>3</sub>	<b>SDRAM Row Address Strobe (SDRAM):</b> When active low, this signal latches Row Address on the positive edge of the clock. This signal also allows Row access and pre-charge.
SCAS[A, B]#	O CMOS	V <sub>3</sub>	<b>SDRAM Column Address Strobe (SDRAM):</b> When active low, this signal latches Column Address on the positive edge of the clock. This signal also allows Column access.
CKE[A, B]	O CMOS	V <sub>3</sub>	<b>SDRAM Clock Enable (SDRAM):</b> When these signals are deasserted, SDRAM enters power-down mode. CKEB is NC and not used by the system electronics.
MD[63:0]	I/O CMOS	V <sub>3</sub>	<b>Memory Data:</b> These signals are connected to the DRAM data bus. They are not terminated on the Celeron processor mobile module MMC-1.

### 3.1.3. PCI (56 Signals)

Table 3 lists the PCI interface signals.

**Table 3. PCI Signal Description**

Name	Type	Voltage	Description
AD[31:0]	I/O PCI	V <sub>3</sub>	<b>Address/Data:</b> The standard PCI address and data lines. The address is driven with FRAME# assertion and data is driven or received in following clocks.
C/BE[3:0]#	I/O PCI	V <sub>3</sub>	<b>Command/Byte Enable:</b> The command is driven with FRAME# assertion and byte enables corresponding to supplied or requested data is driven on the following clocks.
FRAME#	I/O PCI	V <sub>3</sub>	<b>Frame:</b> Assertion indicates the address phase of a PCI transfer. Negation indicates that the cycle initiator desires one more data transfer.
DEVSEL#	I/O PCI	V <sub>3</sub>	<b>Device Select:</b> The 82443DX Host Bridge drives this signal when a PCI initiator is attempting to access DRAM. DEVSEL# is asserted at medium decode time.
IRDY#	I/O PCI	V <sub>3</sub>	<b>Initiator Ready:</b> Asserted when the initiator is ready for data transfer.
TRDY#	I/O PCI	V <sub>3</sub>	<b>Target Ready:</b> Asserted when the target is ready for data transfer.
STOP#	I/O PCI	V <sub>3</sub>	<b>Stop:</b> Asserted by the target to request the master to stop the current transaction.
PLOCK#	I/O PCI	V <sub>3</sub>	<b>Lock:</b> Indicates an exclusive bus operation and may require multiple transactions to complete. When LOCK# is asserted, nonexclusive transactions may proceed. The 82443DX supports lock for CPU initiated cycles only. PCI initiated locked cycles are not supported.
REQ[4:0]#	I PCI	V <sub>3</sub>	<b>PCI Request:</b> PCI master requests for PCI.
GNT[4:0]#	O PCI	V <sub>3</sub>	<b>PCI Grant:</b> Permission is given to the master to use PCI.
PHOLD#	I PCI	V <sub>3</sub>	<b>PCI Hold:</b> This signal comes from the expansion bridge; it is the bridge request for PCI. The 82443DX Host Bridge will drain the DRAM write buffers, drain the processor-to-PCI posting buffers, and acquire the host bus before granting the request via PHLDA#. This ensures that GAT timing is met for ISA masters. The PHOLD# protocol has been modified to include support for passive release.
PHLDA#	O PCI	V <sub>3</sub>	<b>PCI Hold Acknowledge:</b> The 82443DX Host Bridge drives this signal to grant PCI to the expansion bridge. The PHLDA# protocol has been modified to include support for passive release.
PAR	I/O PCI	V <sub>3</sub>	<b>Parity:</b> A single parity bit is provided over AD[31:0] and C/BE[3:0]#.
SERR#	I/O PCI	V <sub>3</sub>	<b>System Error:</b> The 82443DX asserts this signal to indicate an error condition. Please refer to the <i>Intel® 440BX PCIsset Datasheet</i> for further information.
CLKRUN#	I/O D PCI	V <sub>3</sub>	<b>Clock Run:</b> An open-drain output and input. The 82443DX Host Bridge requests the central resource (PIIX4E/M) to start or maintain the PCI clock by asserting CLKRUN#. The 82443DX Host Bridge tri-states CLKRUN# upon deassertion of Reset (since CLK is running upon deassertion of Reset).
PCI_RST#	I CMOS	V <sub>3</sub>	<b>Reset:</b> When asserted, this signal asynchronously resets the 82443DX Host Bridge. The PCI signals also tri-state, compliant with the <i>PCI Rev 2.1 specifications</i> .

### 3.1.4 Processor and PIIX4E/M Sideband (9 Signals)

Table 4 lists the processor and PIIX4E/M sideband interface signals. The voltage level for these signals is determined by V\_CPUIO.

**Table 4. Processor/PIIX4E/M Sideband Signal Descriptions**

Name	Type	Voltage	Description
FERR#	O CMOS	V_CPUIO	<b>Numeric Coprocessor Error:</b> This pin functions as a FERR# signal supporting coprocessor errors. This signal is tied to the coprocessor error signal on the processor and is driven by the processor to the PIIX4E/M.
CPURST	N/C CMOS	V_CPUIO	<b>Processor Reset:</b> The signal is not used in the Celeron processor mobile module MMC-1.
IGNNE#	ID CMOS	V_CPUIO	<b>Ignore Error:</b> This open-drain signal is connected to the Ignore Error pin on the processor and is driven by the PIIX4E/M.
INIT#	ID CMOS	V_CPUIO	<b>Initialization:</b> INIT# is asserted by the PIIX4E/M to the processor for system initialization. This signal is an open-drain.
INTR	ID CMOS	V_CPUIO	<b>Processor Interrupt:</b> INTR is driven by the PIIX4E/M to signal the processor that an interrupt request is pending and needs to be serviced. This signal is an open-drain.
NMI	ID CMOS	V_CPUIO	<b>Non-Maskable Interrupt:</b> NMI is used to force a non-maskable interrupt to the processor. The PIIX4E/M ISA bridge generates NMI when either SERR# or IOCHK# is asserted, depending on how the NMI Status and Control Register is programmed. This signal is an open-drain.
A20M#	ID CMOS	V_CPUIO	<b>Address Bit 20 Mask:</b> When enabled, this open-drain signal causes the processor to emulate the address wraparound at 1 MB, which occurs on the Intel 8086 processor.
SMI#	ID CMOS	V_CPUIO	<b>System Management Interrupt:</b> SMI# is an active low synchronous output from the PIIX4E/M that is asserted in response to one of many enabled hardware or software events. The SMI# open-drain signal can be an asynchronous input to the processor. However, in this chip set SMI# is synchronous to PCLK.
STPCLK#	ID CMOS	V_CPUIO	<b>Stop Clock :</b> STPCLK# is an active low synchronous open-drain output from the PIIX4E/M that is asserted in response to one of many hardware or software events. STPCLK# connects directly to the processor and is synchronous to PCICLK. When the processor samples STPCLK# asserted, it responds by entering a low power state (Quick Start). The processor will only exit this mode when this signal is deasserted.

### 3.1.5 Power Management (8 Signals)

Table 5 lists the power management interface signals. The SM\_CLK and SM\_DATA signals refer to the two-wire serial SMBus interface. Although this interface is currently used

solely for the digital thermal sensor, the SMBus contains reserved serial addresses for future use. See Section 4.9 for more details.

**Table 5. Power Management Signal Descriptions**

Name	Type	Voltage	Description
OEM_PU	I CMOS	V_3	<b>OEM Pullup:</b> This pullup resistor is not required on the Celeron processor mobile module MMC-1.
L2_ZZ	N/C CMOS	V_CPUIO	<b>Low-Power Mode For Cache SRAM:</b> This signal is not used on the Celeron processor mobile module MMC-1.
SUS_STAT#	I CMOS	V_3ALWAYS <sup>1</sup>	<b>Suspend Status:</b> This signal connects to the SUS_STAT1# outputs of PIIX4E/M. It provides information on host clock status and is asserted during all suspend states.
VR_ON	I	V_3	<b>VR_ON:</b> Voltage regulator ON. This 3.3-V (5.0-V tolerant) signal controls the operation of the voltage regulator. VR_ON should be generated as a function of the PIIX4E/MSUSB# signal, which is used for controlling the “Suspend State B” voltage planes. This signal should be driven by a digital signal with a rise/fall time of less than or equal to 1 us. (VIL(max)=0.4V, VIH(min)=3.0V.) See Figure 5, “Power-on-Sequence Timing” for proper sequencing of VR_ON.
VR_PWRGD	O	V_3	<b>VR_PWRGD:</b> This signal is driven high to indicate that the voltage regulator is stable and is pulled low using a 100K resistor when inactive. It can be used in some combination to generate the system PWRGOOD signal.
SM_CLK	I/O D CMOS	V_3	<b>Serial Clock:</b> This clock signal is used on the SMBus interface to the digital thermal sensor. Ensure proper termination based upon the <i>System Management Bus Specification, Revision 1.0</i> .
SM_DATA	I/O D CMOS	V_3	<b>Serial Data:</b> An open-drain data signal on the SMBus interface to the digital thermal sensor. Ensure proper termination based upon the <i>System Management Bus Specification, Revision 1.0</i> .
ATF_INT#	O D CMOS	V_3	<b>ATF Interrupt:</b> This signal is an open-drain output signal of the digital thermal sensor.

NOTE:

V\_3ALWAYS is a 3.3-V supply. It is generated whenever V\_DC is available and supplied to PIIX4E/M resume well.

### 3.1.6 Clock (8 Signals)

Table 6 lists the clock interface signals.

**Table 6. Clock Signal Descriptions**

Name	Type	Voltage	Description															
OEM_PD	I CMOS	V_3	<b>OEM Pulldown:</b> It is renamed from PCI_REF and is not required on the module.															
PCLK	I PCI	V_3S	<b>PCI Clock In:</b> PCLK is an input to the module from the CKDM66-M clock source and is one of the system's PCI clocks. This clock is used by all of the 82443DX Host Bridge logic in the PCI clock domain. This clock is stopped when the PIIX4E/M PCI_STP# signal is asserted and/or during all suspend states.															
HCLK[1:0]	I CMOS	V_CPUIO	<b>Host Clock In:</b> These clocks are inputs to the module from the CKDM66-M clock source and are used by the processor and the 82443DX Host Bridge system controller. This clock is stopped when the PIIX4E/M CPU_STP# signal is asserted and/or during all suspend states.															
SUSCLK	N/C CMOS	V_3	<b>Suspend Clock:</b> This signal is not used on the module.															
FQS[1:0]	O CMOS	V_3S	<p><b>Frequency Status:</b> This signal provides the status of the host clock frequency to the system electronics. These signals are static and are pulled either low or high to the V_3S voltage supply through a 10-kΩ resistor. This module is designed for the 66-MHz strapping option shown below.</p> <table border="1"> <thead> <tr> <th>FQS1</th> <th>FQS0</th> <th>Frequency</th> </tr> </thead> <tbody> <tr> <td>0</td> <td>0</td> <td>60 MHz</td> </tr> <tr> <td><b>0</b></td> <td><b>1</b></td> <td><b>66 MHz</b></td> </tr> <tr> <td>1</td> <td>0</td> <td>Reserved</td> </tr> <tr> <td>1</td> <td>1</td> <td>Reserved</td> </tr> </tbody> </table>	FQS1	FQS0	Frequency	0	0	60 MHz	<b>0</b>	<b>1</b>	<b>66 MHz</b>	1	0	Reserved	1	1	Reserved
FQS1	FQS0	Frequency																
0	0	60 MHz																
<b>0</b>	<b>1</b>	<b>66 MHz</b>																
1	0	Reserved																
1	1	Reserved																
CPU3.3_2.5#	O CMOS	V_CPUIO	<b>Clock Voltage Select:</b> Provides status to the system electronics about the voltage level at which the CKDM66-M clock generator should be operating. This signal is pulled low by module.															

### 3.1.7 Voltages (39 Signals)

Table 7 lists the voltage signal definitions.

**Table 7. Voltage Descriptions**

Name	Type	Number of Pins	Description
V_DC	I	10	<b>DC Input:</b> 5V-21V.
V_3S	I	20	<b>SUSB# controlled 3.3V:</b> V_3S is supplied by the system electronics. This is a 3.3-V power supply that is turned off during suspend during system states STR, STD, and Soff.
V_5	I	1	<b>SUSC# controlled 5V:</b> Power managed 5.0-V supply. An output of the voltage regulator on the system electronics. This rail is off during STD and Soff.
V_3	I	5	<b>SUSC# controlled 3.3V:</b> Power managed 3.3-V supply. An output of the voltage regulator on the system electronics. This rail is off during STD and Soff.
V_CPUIO	O	3	<b>Processor I/O Ring:</b> Powers the processor interface signals such as the PIIX4E/M open-drain pullups for the processor/PIIX4E/Msideband signals and the CKDM66-M clock source.

### 3.1.8 JTAG (7 Signals)

Table 8 lists the JTAG signals, which the system electronics can use to implement a JTAG chain and ITP port, if desired. The JTAG signals provided can not be used as an ITP port.

**Table 8. JTAG Pins**

Name	Type	Voltage	Description
TDO	O	V_CPUIO	<b>JTAG Test Data Out:</b> Serial output port. TAP instructions and data is shifted out of the processor from this port.
TDI	I	V_CPUIO	<b>JTAG Test Data In:</b> Serial input port. TAP instructions and data is shifted into the processor from this port.
TMS	I	V_CPUIO	<b>JTAG Test Mode Select:</b> Controls the TAP controller change sequence.
TCLK	I	V_CPUIO	<b>JTAG Test Clock:</b> Testability clock for clocking the JTAG boundary scan sequence.
TRST#	I	V_CPUIO	<b>JTAG Test Reset:</b> Asynchronously resets the TAP controller in the processor.
ITP(1:0) ITP1 ITPO	O I	V_CPUIO	<b>Debug Port Signals:</b> These signals are not used in the Celeron processor mobile module MMC-1 and should not be connected.

NOTE:

DBREST# (reset target system) on the ITP debug port can be "logically ANDed" with VR\_PWRGD TO PIIX4E/M's PWROK.

### 3.1.9 Miscellaneous (45 Signals)

Table 9 lists the miscellaneous signals.

**Table 9. Miscellaneous Pins**

Name	Type	Number	Description
Module ID[3:0]	O CMOS	4	<b>Module Revision ID:</b> These pins track the revision level of the module. A 100-K pullup resistor to V_3S is required on these signals and should be placed on the system electronics. See Section 7.0, "Labeling Information" for more detail.
PPP_PP#	O CMOS	1	<b>Mobile Celeron processor or mobile Pentium processor present:</b> A high on this signal indicates to the PIIX4E/M ISA bridge CONFIG1 pin that the module is based on the Pentium Pro architecture. A low indicates that the module is of the Pentium processor family. This signal is allowed to float on the module and requires a 100-K pullup resistor to V_3S on the system electronics. This signal is grounded.
Ground	I	32	Ground.
Reserved	RSVD	8	Unallocated Reserved pins and should not be connected.

### 3.2 Connector Pin Assignments

Table 10 lists the signals for each pin of the MMC-1 to the notebook manufacturer's system electronics. Refer to

Section 3.3, "Pin and Pad Assignments" for the pin assignments of the pads on the connector.

**Table 10. Connector Pin Assignments**

Pin Number	Row	Row	Row	Row
	AA	AB	BA	BB
1	GND	GND	GND	GND
2	MD31	MD63	MID0	MID1
3	MD30	MD61	Reserved	Reserved
4	MD29	MD62	V DC	V DC
5	MD27	MD58	V DC	V DC
6	V 3S	V 3S	V DC	V DC
7	MD28	MD60	V DC	V DC
8	MD26	MD56	V DC	V DC
9	MD25	MD57	Reserved	Reserved
10	MD24	MD59	MID2	MID3
11	GND	GND	GND	GND
12	CAS3#/DQM3	CAS7#/DQM7	AD00	FRAME#
13	CAS6#/DQM6	CAS2#/DQM2	AD01	LOCK#
14	MA00	MA01	AD02	DEVSEL#
15	CKEA	CKEB	AD03	IRDY#
16	V 3S	V 3S	V 3S	V 3S
17	MA02	MA04	AD04	TRDY#
18	MA03	MA05	AD05	STOP#
19	MD55	MD22	AD06	PHOLD#
20	MD54	MD23	AD07	PHLDA#
21	GND	GND	GND	GND
22	MD51	MD20	AD08	PCI_RST#
23	MD52	MD21	AD09	PAR
24	MD53	MD19	AD10	SERR#
25	MD49	MD17	AD11	REQ0#
26	V 3S	V 3S	V 3S	REQ1#
27	MD48	MD18	AD12	REQ2#
28	MD50	MD16	AD13	REQ3#
29	SRASA#	SCASA#	AD14	GNT0#
30	SRASB#	SCASB#	AD15	GNT1#
31	GND	GND	GND	GND
32	MWEA#	MECC3	AD16	GNT2#
33	MWEB#	MECC7	AD17	GNT3#
34	RAS0#/CS0#	MECC6	AD18	L2_ZZ
35	RAS1#/CS1#	MECC2	AD19	Reserved
36	V 3S	V 3S	V 3S	V 3S
37	MD14	MECC1	AD20	Reserved
38	MD11	MECC5	AD21	PPP_PP#
39	MD15	MECC4	AD22	CLKRUN#
40	GND	GND	GND	GND
41	MD10	MECC0	RAS2#/CS2#	SM_CLK
42	MD13	MD43	RAS3#/CS3#	SM_DATA
43	MD09	MD41	RAS4#/CS4#	ATF_INT#
44	MD08	MD45	RAS5#/CS5#	SUSCLK
45	V 3S	V 3S	V 3	V 3



	Row	Row	Row	Row
	AA	AB	BA	BB
46	MD12	MD42	AD23	SUS_STAT#
47	MA06	MD40	AD24	V_3
48	MA07	MD44	AD25	OEM_PU
49	MA08	MD46	AD26	VR_ON
50	GND	GND	GND	GND
51	MA09	MD47	AD27	VR_PWRGD
52	CAS1#/DQM1	CAS5#/DQM5	AD28	V_3
53	CAS4#/DQM4	CAS0#/DQM0	AD29	V_3
54	MA10	MA12	AD30	Reserved
55	V_3S	V_3S	V_3S	Reserved
56	MA11	MA13	AD31	INIT#
57	MD39	MD07	C/BE0#	V_CPUIO
58	MD37	MD02	C/BE1#	INTR
59	MD38	MD00	C/BE2#	CPURST
60	GND	GND	GND	GND
61	MD36	MD04	C/BE3#	STPCLK#
62	MD33	MD01	IGNNE#	SMI#
63	MD35	MD03	FERR#	NMI
64	MD32	MD06	A20M#	V_5
65	MD34	MD05	V_CPUIO	V_CPUIO
66	V_3S	V_3S	TDO	TRST#
67	OEM_PD	PCLK	ITP0	TDI
68	FQS0	FQS1	ITP1	TMS
69	HCLK1	HCLK0	CPU3.3_2.5#	TCLK
70	GND	GND	GND	GND

### 3.3 Pin and Pad Assignments

The MMC-1 surface mount connector has a 0.6-millimeter pitch and has 280 pins. For size information, refer to Section

5.1.4 "Height Restrictions". Figure 2 shows the connector pad assignments for the manufacturer's system electronics.

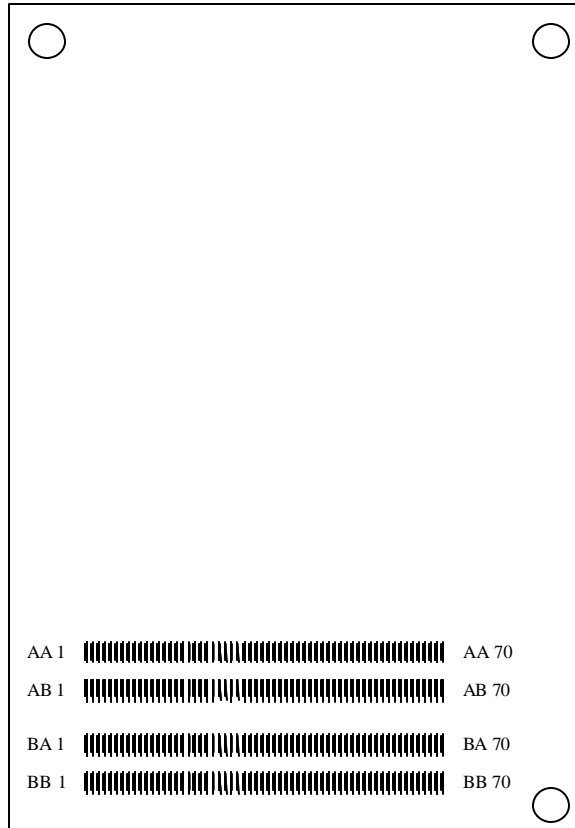

Figure 2. 280-Pin Connector Footprint Pad Numbers, Module Secondary Side

Table 11 summarizes the key specifications for the MMC-1 connector.

**Table 11. Connector Specifications**

Parameter	Condition	Specification
Material	Contact	Copper Alloy
	Housing	Thermo Plastic Molded Compound: LCP
Electrical	Current	0.5 A
	Voltage	50 VAC
	Insulation Resistance	100 MΩ minimum at 200 VDC
	Termination Resistance	50 mΩ maximum
	Capacitance	5 pF maximum per contact
Mechanical	Mating Cycles	50 cycles
	Connector Mating Force	3.2 oz per contact
	Contact Unmating Force	0.35 oz per contact

#### 4.0 FUNCTIONAL DESCRIPTION

##### 4.1 Celeron Processor Mobile Module MMC-1

The Celeron processor mobile module MMC-1 is offered at speeds of 400 megahertz, 366 megahertz, 333 megahertz, 300 megahertz, and 266 megahertz. All processor speeds have a PSB speed of 66 megahertz.

##### 4.2 L2 Cache

The on-die L2 cache is 128 kilobytes, is four-way set associative, and runs at the speed of the processor core.

##### 4.3 The 82443DX Host Bridge System Controller

Intel's 82443DX Host Bridge system controller combines the mobile Celeron processor bus controller, the DRAM controller, and the PCI bus controller into one component. The 82443DX Host Bridge has multiple power management features designed specifically for notebook systems such as:

- CLKRUN#, a feature that enables controlling of the PCI clock on or off.
- The 82443DX Host Bridge suspend modes, which include Suspend-to-RAM (STR), Suspend-to-Disk (STD), and Powered-on-Suspend (POS).
- System Management RAM (SMRAM) power management modes, which include Compatible SMRAM (C\_SMRAM) and Extended SMRAM (E\_SMRAM). C\_SMRAM is the traditional SMRAM feature implemented in all Intel PCI chipsets. E\_SMRAM is a new feature that supports write-back cacheable SMRAM space up to 1 megabyte. To minimize power consumption while the system is idle,

the internal 82443DX Host Bridge clock is turned off (gated off). This is accomplished by setting the G\_CLK enable bit in the power management register in the 82443DX through the system BIOS.

##### 4.3.1 Memory Organization

The MMC-1 connector signaling interface supports the 82443DX Host Bridge standard mode, memory configurations, and modes of operation. This allows the memory interface to support the following:

- One set of memory control signals, sufficient to support up to three SO-DIMM sockets and six banks of SDRAM at 66 megahertz.
- One CKE signal for each bank.

Memory features not supported by the 82443DX Host Bridge system controller standard MMC-1 mode are:

- Support for eight banks of memory.
- Second set of memory address lines (MAA[13:0]).
- Accelerated Graphics Port (AGP).

The 82443DX Host Bridge system controller supports DRAM technologies EDO and SDRAM. These memory types should not be mixed in the system, so that all DRAM in all rows (RAS[5:0]#) must be of the same technology. The 82443DX Host Bridge system controller targets 60-nanosecond EDO DRAMs, and 66-megahertz SDRAMs.

The Celeron processor mobile module's clocking architecture supports the use of SDRAM. Tight timing requirements of the 66-megahertz SDRAM clocks allow all host and SDRAM clocks to be generated from the same clocking architecture on the system electronics. For complete details about using SDRAM memory and for trace

length guidelines, refer to the *Mobile Pentium® II processor / 82443BX PCIset Advanced Platform Recommended Design and Debug Practices*. Refer to the *Intel® 440BX PCIset Datasheet* for details on memory device support, organization, size, and addressing.

#### 4.3.2 Reset Strap Options

Several strap options on the memory address bus define the behavior of the Celeron processor mobile module MMC-1 after reset. Other straps are allowed to override the default settings. Table 12 shows the various straps and their implementation.

**Table 12. Configuration Straps for the 82443DX Host Bridge System Controller**

Signal	Function	Module Default Setting
MAB[12]#	Host Frequency Select	No strap—66-MHz default.
MAB[11]#	In order queue depth	No strap—maximum queue depth is set, i.e. 8.
MAB[10]	Quick Start select	Strapped high on the module for Quick Start mode.
MAB[9]#	AGP disable	Strapped to disable AGP.
MAB[7]#	MM Config	Strapped for MMC-1 compatible mode.
MAB[6]#	Host Bus Buffer Mode select	Strapped high on the module for mobile PSB buffers.

*Celeron® Processor Mobile Module: Mobile Module Connector 2 (MMC-2).*

#### 4.3.3 PCI Interface

The PCI interface of the 82443DX Host Bridge is available at the connector. The 82443DX Host Bridge supports the PCI Clockrun protocol for PCI bus power management. In this protocol, PCI devices assert the CLKRUN# open-drain signal when they require the use of the PCI interface. Refer to the *PCI Mobile Design Guide* for complete details on the PCI Clockrun protocol.

The 82443DX Host Bridge is responsible for arbitrating the PCI bus. With the MMC-1 connector the 82443DX Host Bridge can support up to five PCI bus masters. There are five PCI Request/Grant pairs, REQ[4:0]# and GNT[4:0]#, available to the manufacturer's system electronics.

*The PCI interface on the connector is 3.3 volts only. All devices that drive outputs to a 5.0V<sub>t</sub> nominal V<sub>oh</sub> level are not supported.*

The 82443DX Host Bridge system controller is compliant with the PCI 2.1 specification, which improves the worst case PCI bus access latency from earlier PCI specifications. As detailed in the PCI specification, the 82443DX Host Bridge supports only Mechanism #1 for accessing PCI configuration space. This implies that signals AD[31:11] are available for PCI IDSEL signals. However, since the 82443DX Host Bridge is always device #0, AD11 will never be asserted during PCI configuration cycles as an IDSEL. The 82443DX reserves AD12 for the AGPbus, which is not supported by the MMC-1 connector. Thus, AD13 is the first available address line usable as an IDSEL. AD18 should be used by the PIIx4E/M.

#### 4.3.4 AGP Feature Set

The Intel MMC-1 family does not support the AGP graphics port interface. For AGP information, refer to the *Intel®*

#### 4.4 Power Management

##### 4.4.1 Clock Control Architecture

The Celeron processor mobile module's clock control architecture is optimal for notebook designs. The clock control architecture consists of seven different clock states: Normal, Stop Grant, Auto Halt, Quick Start, HALT/Grant Snoop, Sleep, and Deep Sleep. The Auto Halt state provides a low power clock state that can be controlled through the software execution of the HLT instruction. The Quick Start state provides a low-power, low-exit latency clock state that can be used for hardware controlled "idle" computer states. The Deep Sleep state provides an extremely low-power state that can be used for Power-on-Suspend states, which is an alternative to shutting off the processor's power.

The exit latency of the Deep Sleep state has been reduced to 30 microseconds. The Stop Grant and Sleep states are not available on the Celeron processor mobile module as these states are intended for desktop or server systems. The Stop Grant and the Quick Start clock states are mutually exclusive. For example a strapping option on signal A15# chooses which state is entered when the STPCLK# signal is asserted. Strapping the A15# signal to ground at Reset enables the Quick Start state. Otherwise, asserting the STPCLK# signal puts the mobile Celeron processor into the Stop Grant state. The Stop Grant state is useful for SMP platforms and is not supported on the Celeron processor mobile module MMC-1. The Quick Start state is available on the module and provides a significantly lower power level. Figure 3 provides an illustration of the clocking architecture. Performing state transitions not shown in Figure 3 is neither recommended nor supported.

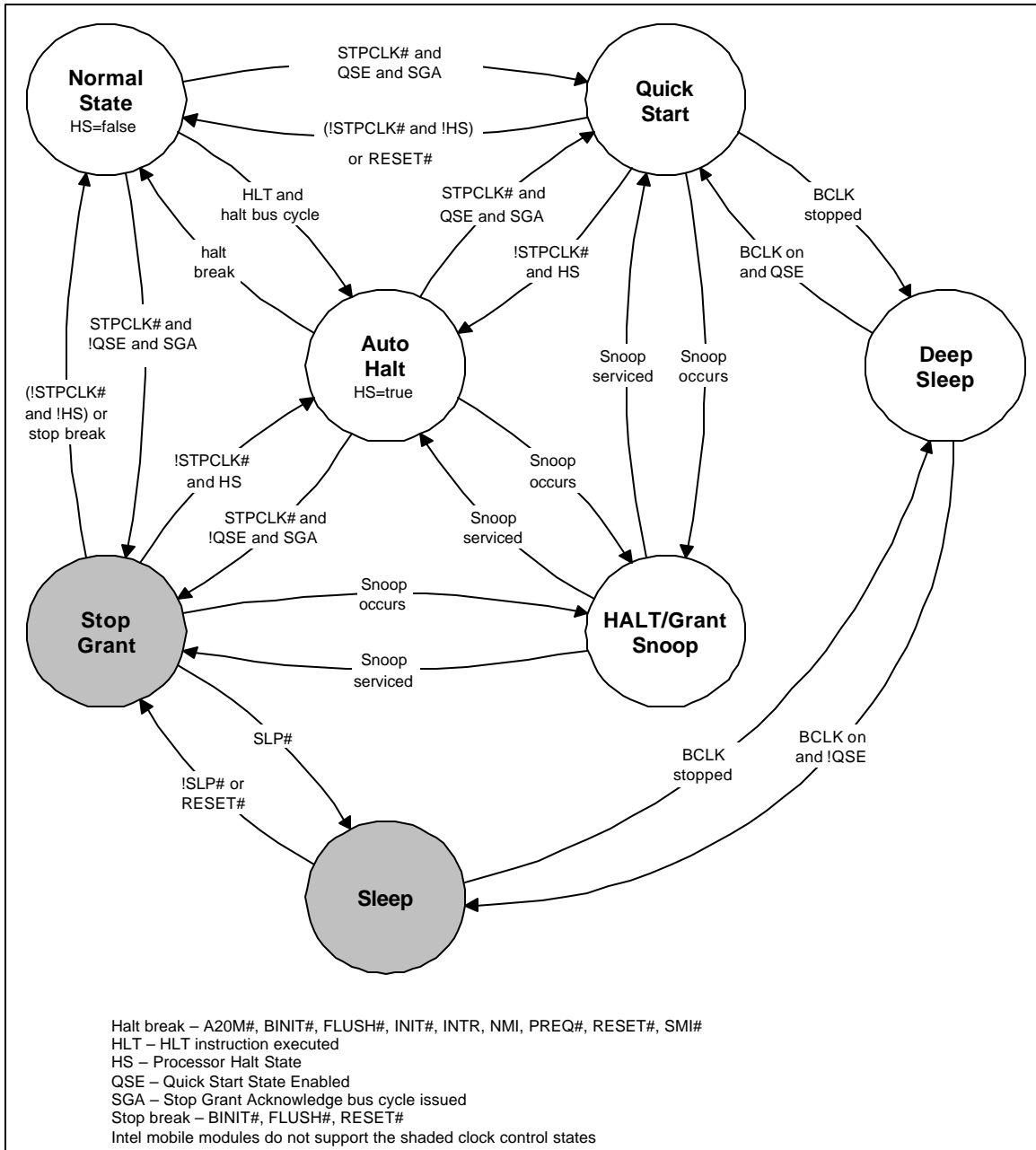

Figure 3. Clock Control States

#### 4.4.2 Normal State

This is the normal operating mode. The processor's core clock is running and the processor is actively executing instructions.

#### 4.4.3 Auto Halt State

This is a low-power mode entered by the processor through the execution of the HLT instruction. The power level of this mode is similar to the Stop Grant state. A transition to the Normal state is made by a halt break event (one of the following signals going active: NMI, INTR, BINIT#, INIT#, RESET#, FLUSH#, or SMI#).

Asserting the STPCLK# signal while in the Auto Halt state will cause the processor to transition to the Stop Grant or Quick Start state, which issues a Stop Grant Acknowledge bus cycle. Deasserting STPCLK# will cause the processor to return to the Auto Halt state without issuing a new Halt bus cycle.

The SMI# (System Management Interrupt) is recognized in the Auto Halt state. Returning from the SMI handler can be to either the Normal state or the Auto Halt state. See the *Intel® Architecture Software Developer's Manual, Volume III: System Programmer's Guide* for more information. No Halt bus cycle is issued when returning to the Auto Halt state from System Management Mode (SMM).

The FLUSH# signal is serviced in the Auto Halt state. After flushing the on-chip, the processor will return to the Auto Halt state without issuing a Halt bus cycle. Transitions in the A2OM# and PREQ# signals are recognized while in the Auto Halt state.

#### 4.4.4 Stop Grant State

Intel mobile modules do not support the Stop Grant state.

The processor enters this mode with the assertion of the STPCLK# signal when it is configured for Stop Grant state (via the A15# strapping option). The processor still responds to snoop requests and latch interrupts. Latched interrupts will be serviced when the processor returns to the Normal state. Only one occurrence of each interrupt event will be latched. A transition back to the Normal state can be made by the deassertion of the STPCLK# signal or the occurrence of a stop break event (a BINIT#, FLUSH#, or RESET# assertion).

The processor will return to the Stop Grant state after the completion of a BINIT# bus initialization unless STPCLK# has been deasserted. RESET# assertion will cause the processor to immediately initialize itself, but the processor will stay in the Stop Grant state after initialization until STPCLK# is deasserted. If the FLUSH# signal is asserted, the processor will flush the on-chip caches and return to the Stop Grant state. A transition to the Sleep state can be made by the assertion of the SLP# signal.

While in the Stop Grant state, assertions of SMI#, INIT#, INTR, and NMI (or LINT[1:0]) will be latched by the

processor. These latched events will not be serviced until the processor returns to the Normal state. Only one of each event will be recognized upon return to the Normal state.

#### 4.4.5 Quick Start State

This is a mode entered by the processor with the assertion of the STPCLK# signal when it is configured for the Quick Start state (via the A15# strapping option). In the Quick Start state the processor is only capable of acting on snoop transactions generated by the PSB priority device. Because of its snooping behavior, Quick Start can only be used in single processor configurations.

A transition to the Deep Sleep state can be made by stopping the clock input to the processor. A transition back to the Normal state (from the Quick Start state) is made only if the STPCLK# signal is deasserted.

While in this state the processor is limited in its ability to respond to input. It is incapable of latching any interrupts, servicing snoop transactions from symmetric bus masters, or responding to FLUSH# or BINIT# assertions. While the processor is in the Quick Start state, it will not respond properly to any input signal other than STPCLK#, RESET#, or BPR1#. If any other input signal changes, then the behavior of the processor will be unpredictable. No serial interrupt messages may begin or be in progress while the processor is in the Quick Start state.

RESET# assertion will cause the processor to immediately initialize itself, but the processor will stay in the Quick Start state after initialization until STPCLK# is deasserted.

#### 4.4.6 HALT/Grant Snoop State

The processor will respond to snoop transactions on the PSB while in the Auto Halt state, the Stop Grant state, or the Quick Start state. When a snoop transaction is presented on the PSB the processor will enter the HALT/Grant Snoop state. The processor will remain in this state until the snoop has been serviced and the PSB is quiet. After the snoop has been serviced, the processor will return to its previous state. If the HALT/Grant Snoop state is entered from the Quick Start state, then the input signal restrictions of the Quick Start state still apply in the HALT/Grant Snoop state, except for those signal transitions that are required to perform the snoop.

#### 4.4.7 Sleep State

Intel mobile modules do not support the Sleep state.

The Sleep state is a very low power state in which the processor maintains its context and the phase-locked loop (PLL) maintains phase lock. The Sleep state can only be entered from the Stop Grant state. After entering the Stop Grant state the SLP# signal can be asserted, causing the

processor to enter the Sleep state. The SLP# signal is not recognized in the Normal state or the Auto Halt state. The processor can be reset by the RESET# signal while in the Sleep state. If RESET# is driven active while the processor is in the Sleep state, then SLP# and STPCLK# must immediately be driven inactive to ensure that the processor correctly initializes itself.

Input signals (other than RESET#) may not change while the processor is in the Sleep state or transitioning into or out of the Sleep state. Input signal changes at these times will cause unpredictable behavior. Thus, the processor is incapable of snooping or latching any events in the Sleep state.

While in the Sleep state the processor can enter its lowest power state, the Deep Sleep state. Removing the processor's input clock puts the processor in the Deep Sleep state. PICCLK may be removed in the Sleep state.

#### 4.4.8 Deep Sleep State

The Deep Sleep state is the lowest power mode the processor can enter while maintaining its context. Stopping the BCLK input to the processor enters Sleep state. For proper operation, the BCLK input should be stopped in the low state.

The processor will return to the Sleep state or the Quick Start state from the Deep Sleep state when the BCLK input is restarted. Due to the PLL lock latency, there is a 30-millisecond delay after the clocks have started before this state transition happens. PICCLK may be removed in the Deep Sleep state. PICCLK should be designed to turn on when BCLK turns on when transitioning out of the Deep Sleep state.

The input signal restrictions for the Deep Sleep state are the same as for the Sleep state, except that RESET# assertion will result in unpredictable behavior.

**Table 13. Clock State Characteristics**

Clock State	Exit Latency	Processor Power	Snooping	System Uses
Normal	N/A	Varies	Yes	Normal program execution
Auto Halt	Approximately 10 bus clocks	1.2W	Yes	S/W controlled entry idle mode
Stop Grant <sup>1</sup>	10 bus clocks	1.2W	Yes	H/W controlled entry/exit mobile throttling
Quick Start	Through snoop, to HALT/Grant Snoop state: immediate Through STPCLK#, to Normal state: 10 bus clocks	0.5W	Yes	H/W controlled entry/exit mobile throttling
HALT/Grant Snoop <sup>1</sup>	A few bus clocks after the end of snoop activity.	Not specified	Yes	Supports snooping in the low power states
Sleep	To Stop Grant state 10 bus clocks	0.5W	No	H/W controlled entry/exit desktop idle mode support
Deep Sleep	30 msec	150 mW	No	H/W controlled entry/exit mobile powered-on suspend support

NOTES:

1. Intel mobile modules do not support shaded clock control states.
2. Not 100% tested. Specified at 50°C by design/characterization.

#### 4.5 Typical POS and STR Power

Table 14 lists the POS and STR typical power specifications.

**Table 14. POS and STR Power**

State	Typical MMC-1 Power
POS	0.475W
STR	0.018W

NOTE:

These are average values of measurement and are guidelines only.

#### 4.6.1 DC Requirements

#### 4.6 Electrical Requirements

Table 15 provides DC power supply design criteria.

The following section provides information on the electrical requirements for the Celeron processor mobile module MMC-1.

**Table 15. Power Supply Design Specifications<sup>1</sup>**

Symbol	Parameter	Min	Nom	Max	Unit	Notes
$V_{DC}^{2,3}$	DC Input Voltage	5.0	12.0	21.0	V	
$I_{DC}$	DC Input Current	0.1	0.9	3.5	A	
$I_{DC-Surge}$	Maximum Surge Current for $V_{DC}$			17.3	A	
$I_{DC-Leakage}^4$	Typical Leakage Current for $V_{DC}$		4.0		$\mu A$	(at 25°C)
$V_5$	Power Managed 5V Voltage Supply	4.75	5.0	5.25	V	
$I_5$	Power Managed 5V Current	17	32	60	mA	
$I_5-Surge$	Maximum Surge Current for $V_5$			0.6	A	
$I_5-Leakage$	Typical Leakage Current for $V_5$		1.0		$\mu A$	
$V_3$	Power Managed 3.3V Voltage Supply	3.135	3.3	3.465	V	
$I_3$	Power Managed 3.3V Current	0.8	1.2	2.0	A	
$I_3-Surge$	Maximum Surge Current for $V_3$			2.8	A	
$I_3-Leakage$	Typical Leakage Current for $V_3$		1.1		mA	
$V_{3S}$	Power Managed 3.3V Voltage Supply	3.135	3.3	3.465	V	
$I_{3S}$	Power Managed 3.3V Current	—	0.35	0.5	mA	
$I_{3S-Surge}$	Maximum Surge Current for $V_{3S}$	—	—	TBD	A	
$I_{3S-Leakage}$	Typical Leakage Current for $V_{3S}$	TBD	TBD	TBD	mA	
$V_{CPU}$	Processor I/O Ring Voltage	2.375	2.5	2.625	V	$\pm 0.125$
$I_{CPU}^5$	Processor I/O Ring Current	0	10	20	mA	
$V_{CLK}$	Processor Clock Rail Voltage	2.375	2.5	2.625	V	$\pm 0.125$
$I_{CLK}^5$	Processor Clock Rail Current	24.0	35.0	80.0	mA	

**NOTES:**

1. Unless otherwise noted, all specifications in this table apply to all Intel mobile module frequencies.
2.  $V_{DC}$  is set for 12V in order to determine typical  $V_{DC}$  current.
3.  $V_{DC}$  is set for 5V in order to determine maximum  $V_{DC}$  current.
4. Leakage current that can be expected when  $VR_{ON}$  is deactivated and  $V_{DC}$  is still applied.
5. These values are system dependent.



#### 4.6.2 AC Requirements

Table 16 provides the PSB clock (BCLK) AC requirements for the Celeron processor mobile module MMC-1.

**Table 16. BCLK AC Specifications at the Processor Core Pins**<sup>1,2,3</sup>

T#	Parameter	Min	Nom	Max	Unit	Figure	Notes
	PSB Frequency <sup>4</sup>		66.67		MHz		All processor core frequencies
T1:	BCLK Period <sup>4,5</sup>		15.0		ns		
T2:	BCLK Period Stability <sup>6,7,8</sup>			±250	ps		
T3:	BCLK High Time	5.3			ns		At >1.8V
T4:	BCLK Low Time	5.3			ns		At <0.7V
T5:	BCLK Rise Time <sup>8</sup>	0.175		0.875	ns		(0.9V-1.6V)
T6:	BCLK Fall Time <sup>8</sup>	0.175		0.875	ns		(1.6V-0.9V)

**NOTES:**

1. Unless otherwise noted, all specifications in this table apply to all Intel mobile modules.
2. All AC timings for the GTL+ signals are referenced to the BCLK rising edge at 1.25V at the processor core pin. All GTL+ signal timings (address bus, data bus, etc.) are referenced at 1.00V at the processor core pins.
3. All AC timings for the CMOS signals are referenced to the BCLK rising edge at 1.25V at the processor core pin. All CMOS signal timings (compatibility signals, etc.) are referenced at 1.25V at the processor core pins.
4. The internal core clock frequency is derived from the PSB clock. The PSB clock to core clock ratio is determined during initialization as described and is predetermined by the Celeron processor mobile module.
5. The BCLK period allows +0.5 ns tolerance for clock driver variation. See the *CK97 Clock Synthesizer/Driver Specification* for further information.
6. Measured on the rising edge of adjacent BCLKs at 1.25V. The jitter present must be accounted for as a component of BCLK skew between devices.
7. The clock driver's closed loop jitter bandwidth must be set low to allow any PLL-based device to track the jitter created by the clock driver. The -20 dB attenuation point, as measured into a 10-pF to 20-pF load, should be less than 500 kHz. This specification may be ensured by design characterization and/or measured with a spectrum analyzer. See the *CK97 Clock Synthesizer/Driver Specification* for further details.
8. Not 100% tested. Specified by design characterization as a clock driver requirement.

#### 4.6.2.1 BCLK Signal Quality Specifications and Measurement Guidelines

Table 17 describes the signal quality specifications at the processor core for the BCLK signal. Figure 4 describes the signal quality waveform for the BCLK at the processor core pins.

**Table 17. BCLK Signal Quality Specifications at the Processor Core**

T#	Parameter	Min	Max	Unit
V1:	BCLK $V_{IL}$ <sup>2</sup>		0.7	V
V2:	BCLK $V_{IH}$ <sup>2</sup>	1.8		V
V3:	$V_{IN}$ Absolute Voltage Range <sup>3</sup>	-0.8	3.5	V
V4:	Rising Edge Ringback <sup>4</sup>	1.8		V
V5:	Falling Edge Ringback <sup>4</sup>		0.7	V
	BCLK rising/falling slew-rate	0.8	4	V/ns

**NOTES:**

1. Unless otherwise noted, all specifications in this table apply to all Intel mobile modules.
2. BCLK must rise and fall monotonically between  $V_{IL,BCLK}$  and  $V_{IH,BCLK}$ .
3. The mobile Celeron processor PSB clock overshoot and undershoot specification for 66-megahertz operation.
4. The rising and falling edge ringback voltage specified is the minimum (rising) or maximum (falling) absolute voltage the BCLK signal can dip back to after passing the  $V_{IH}$  (rising) or  $V_{IL}$  (falling) voltage limits.
5. For proper signal termination, refer to the Clocking Guidelines in the *Mobile Pentium® II Processor / 440BX PCIsset Advanced Platform Recommend Design and Debug Practices*.

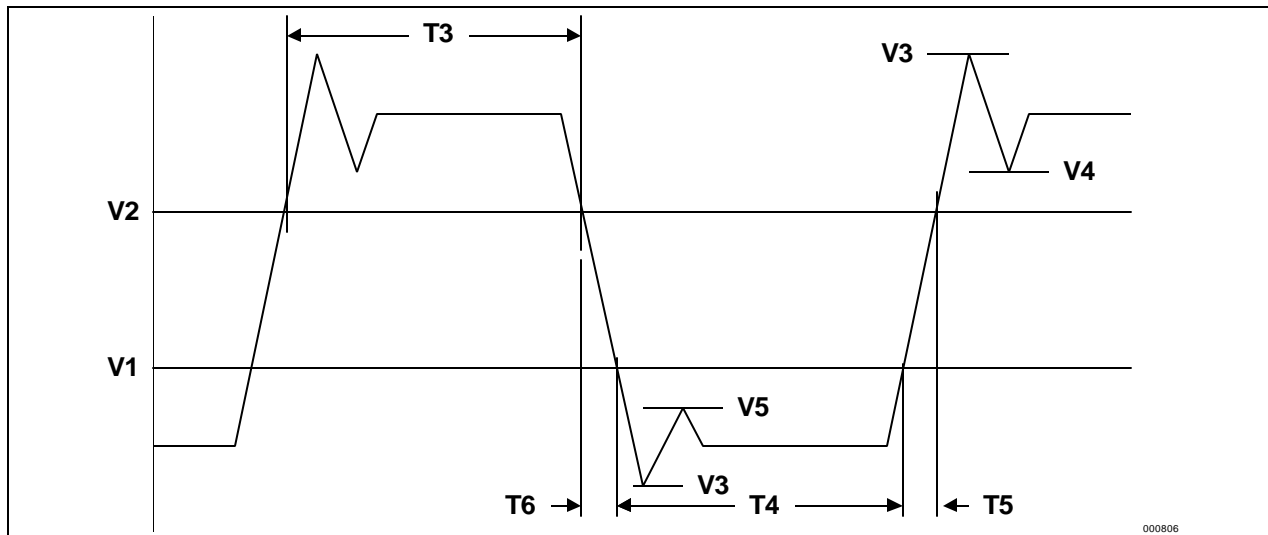

**Figure 4. BCLK, TCK, and PICCLK Generic Clock Waveform at the Processor Core Pin**

#### 4.7 The Voltage Regulator

The DC voltage regulator (DC/DC converter) provides the appropriate core voltage, the I/O ring voltage, and the sideband signal pullup voltage for the Celeron processor mobile module. The voltage range is 5 volts to 21 volts.

#### 4.7.1 Voltage Regulator Efficiency

Table 18 lists the voltage regulator efficiencies.

Table 18. Typical Voltage Regulator Efficiency

I <sub>core</sub> , A <sup>3</sup>	V <sub>DC</sub> , V	I <sub>DC</sub> , A <sup>2</sup>	Efficiency <sup>1</sup>
1	5.0	0.370	82.8%
2	5.0	0.702	88.8%
3	5.0	1.044	89.8%
4	5.0	1.404	89.7%
5	5.0	1.762	88.1%
6	5.0	2.144	86.4%
7	5.0	2.528	85.0%
1	12.0	0.159	79.7%
2	12.0	0.295	87.0%
3	12.0	0.438	87.8%
4	12.0	0.584	87.3%
5	12.0	0.736	86.1%
6	12.0	0.890	84.9%
7	12.0	1.043	83.8%
1	21.0	0.091	79.3%
2	21.0	0.170	86.0%
3	21.0	0.253	87.3%
4	21.0	0.340	85.3%
5	21.0	0.429	84.1%
6	21.0	0.519	82.9%
7	21.0	0.617	80.7%

NOTES:

1. These efficiencies will change with future voltage regulators that accommodate wider ranges of input voltages.
2. With V<sub>DC</sub> applied and the voltage regulator off, typical leakage is 0.3 mA with a maximum of 0.7 mA.
3. I<sub>core</sub> indicates the CPU core current being drawn during test and measurement.

#### 4.7.2 Control of the Voltage Regulator

The VR\_ON pin turns the DC voltage regulator on or off. The VR\_ON pin should be controlled as a function of the SUSB#, which controls the system's power planes. VR\_ON should switch high only when the following conditions are met: V<sub>5(s)</sub> => 4.5 volts and V<sub>DC</sub> => 4.75 volts.

**Caution-** Turning on VR\_ON prior to meeting these conditions will severely damage the Celeron processor mobile module.

The VR\_PWRGD signal indicates that the voltage regulator power is operating at a stable voltage level. Use VR\_PWRGD on the system electronics to control power inputs and to gate PWROK to the PIIX4E/M.

Table 19 lists the voltage signal definitions and sequences, and Figure 5 shows the signal sequencing and the voltage planes sequencing required for normal operation of the Celeron processor mobile module MMC-1.

#### 4.7.2.1 Voltage Signal Definition and Sequencing

Table 19. Voltage Signal Definitions and Sequences

Signal	Source	Definitions and Sequences
V_DC	System Electronics	DC voltage is driven from the power supply and is required to be between 5V and 21V DC. V_DC powers the module's DC-to-DC converter for processor core and I/O voltages. It cannot be hot inserted or removed while V_DC is powered on.
V_3	System Electronics	V_3 is supplied by the system electronics for the 82443DX.
V_5	System Electronics	V_5 is supplied by the system electronics for the 82443DX's 5.0-V reference voltage and the voltage regulator.
V_3S	System Electronics	V_3S is supplied by the system electronics. This is a 3.3-V power supply that is turned off during suspend during system states STR, STD and Soft.
VR_ON	System Electronics	Enables the voltage regulator circuit. When driven active high (3.3V) the voltage regulator circuit on the module is activated. The signal driving VR_ON should be a digital signal with a rise and fall time of less than or equal to 1 $\mu$ s. (VIL (max)=0.4V, VIH (min)=3.0V).
V_CORE (also a host bus GTL+ termination voltage VTT)	Module	A result of VR_ON being asserted, V_CORE is an output of the DC-DC regulator on the module and is driven to the core voltage of the processor. It is also used as the host bus GTL+ termination voltage, known as VTT.
V_BSB_IO	Module	V_BSB_IO is 1.8V. The system electronics uses this voltage to power the L2 cache-to-processor interface circuitry.
VR_PWRGD	Module	Upon sampling the voltage level of V_CORE (minus tolerances for ripple), VR_PWRGD is driven active high. If VR_PWRGD is not sampled active within 1 second of the assertion of VR_ON, then the system electronics should deassert VR_ON. After V_CORE is stabilized, VR_PWRGD will assert to logic high (3.3V). This signal <i>must not be pulled up</i> by the system electronics. VR_PWRGD should be "ANDed" with V_3s to generate the PIIX4E/M input signal, PWROK. The system electronics should monitor VR_PWRGD to verify it is asserted high prior to the active high assertion of PIIX4E/M PWROK.
V_CPUIO	Module	V_CPUIO is 2.5V. The system electronics uses this voltage to power the PIIX4E/M-to-processor interface circuitry, as well as the HCLK(0:1) drivers for the processor clock.

The following list provides additional specifications and clarifications of the power sequence timing and Figure 5 provides an illustration of the power sequence timing.

1. The VR\_ON signal *may only be* asserted to a logical high by a digital signal *after*  $V_{DC} \geq 4.7$  volts,  $V_5 \geq 4.5$  volts, and  $V_3 \geq 3.0$  volts.
2. The Rise Time and Fall Time of VR\_ON *must be* less than or equal to 1 *microsecond* when it goes through its Vil to Vih.
3. VR\_ON has its Vil(max) = +0.4 volts and Vih(min) = +3.0 volts.
4. The VR\_PWRGD will get asserted to logic high (3.3 volts) after V\_CORE is stabilized and V\_DC reaches 5.0 volts. This signal should not and can not be pulled up by the system electronics.
5. In the power-on process, Intel recommends to raise the higher voltage power plane first (V\_DC), followed by the lower power planes (V\_5, V\_3), and finally assert VR\_ON after above voltage levels are met on all rails. The power-off process should be the reverse process, i.e. VR\_ON gets deasserted, followed by the lower power planes, and finally the higher power plane.
6. VR\_ON must monotonically rise through its Vil to Vih and fall through its Vih to Vil points. The sign of slope can not change between Vil and Vih in rising and Vih and Vil in falling.
7. VR\_ON must provide an instantaneous in-rush current to the module with the following values as listed in Table 20.

**Table 20. VR\_ON In-rush Current**

	Instantaneous	DC Operating
MAX	41.0 mA	0.1 $\mu$ A
TYP	0.2 mA	0.0 $\mu$ A

NOTE:

These values are based on a 3.3V VR\_ON signal.

8. VR\_ON Valid-Low Time: This specifies how long VR\_ON needs to be low for a valid off before VR\_ON can be turned back on again. In going from a valid on to off and then back on, the following conditions must be met to prevent damage to the OEM system or the Intel mobile module:
- VR\_ON must be low for 1 millisecond.
  - The original voltage level requirements for turn-on must be met before assertion of VR\_ON (i.e.  $V_{DC} \geq 4.7$  volts,  $V_5 \geq 4.5$  volts, and  $V_3 \geq 3.0$  volts).

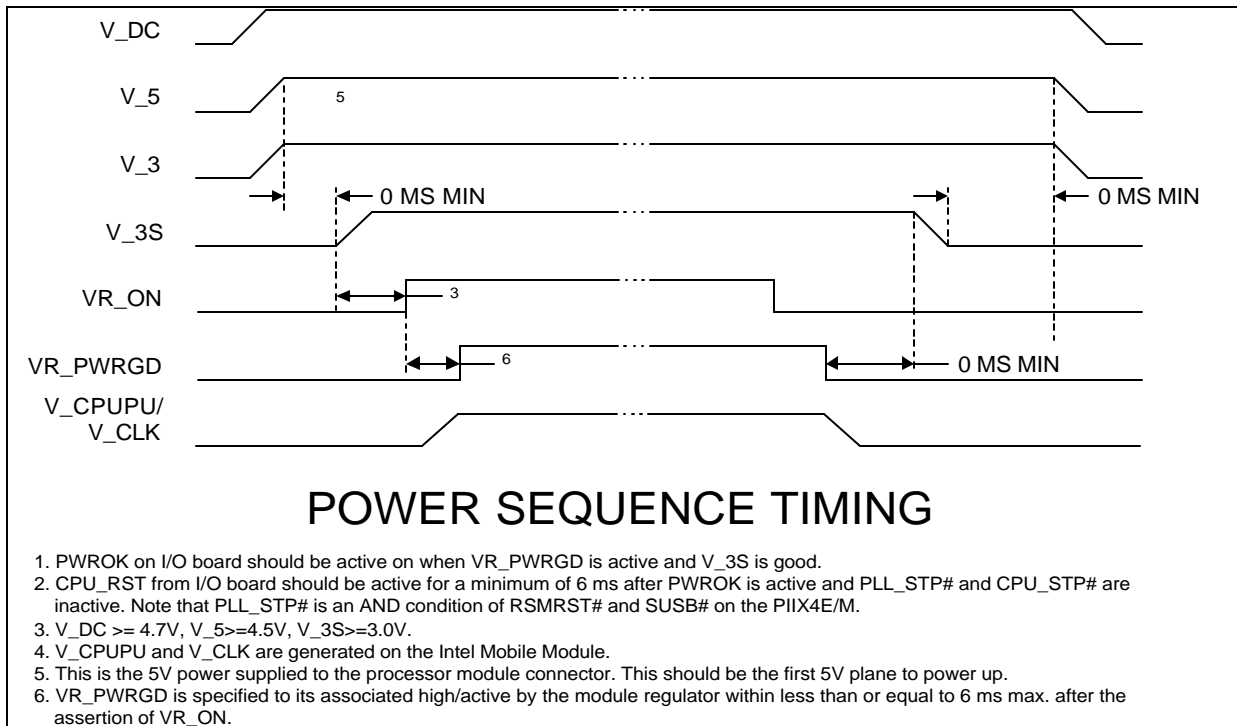

**Figure 5. Power-on Sequence Timing**

#### 4.7.3 Power Planes: Bulk Capacitance Requirements

In order to provide adequate filtering and in-rush current protection for any system design, bulk capacitance is required. A small amount of bulk capacitance is supplied on

the module. However, in order to achieve proper filtering additional capacitance should be placed on the system electronics.

Table 21 details the bulk capacitance requirements for the system electronics.

Table 21. Capacitance Requirements per Power Plane

Power Plane	Capacitance Requirements	ESR	Ripple Current	Rating
V_DC	100 uf, 0.1 uf, 0.01 uf <sup>1</sup>	20 mΩ	1-3.5A <sup>3</sup>	20% tolerance at 35V
V_5	100 uf, 0.1 uf, 0.01 uf <sup>1</sup>	100 mΩ	1A	20% tolerance at 10V
V_3	470 uf, 0.1 uf, 0.01 uf <sup>1</sup>	100 mΩ	1A	20% tolerance at 6V
V_3S	100 uf, 0.1 uf, 0.01 uf <sup>1</sup>	100 mΩ	N/A	20% tolerance at 6V
V_CPUIO <sup>2</sup>	2.2 uf, 8200 pf <sup>1</sup>	N/A	N/A	20% tolerance at 6V

NOTES:

1. Placement of above capacitance requirements should be located near the connector.
2. V\_CPUIO filtering should be located next to the system clock synthesizer.
3. Ripple current specification depends on V\_DC input. For 5.0-V V\_DC, a 3.5A device is required.
4. For V\_DC at 18V or higher, 1A is sufficient.

#### 4.7.4 Surge Current Guidelines

This section provides the results of a worst case, surge current analysis. The analysis determines the maximum amount of surge current that the Celeron processor mobile module MMC-1 can manage.

In the analysis, the module has two 4.7 microfarads with an ESR of 0.15 ohms total. The MMC-1 connector is approximately 30 milliohms of series resistance, for a total series resistance of .18 ohms. If the user powers the system

with the A/C adapter (18 volts), the amount of surge current on the module would be approximately 100 amperes. This information is also used to develop I/O bulk capacitance requirements. See Table 20 for more information.

**Note:** Depending on the system electronics design, different impedances may yield different result. A thorough analysis should be performed to understand the implications of surge current on their system.

Figure 6 shows an electrical model used when analyzing instantaneous power-on conditions, and Figure 7 illustrates the results with a SPICE simulation.

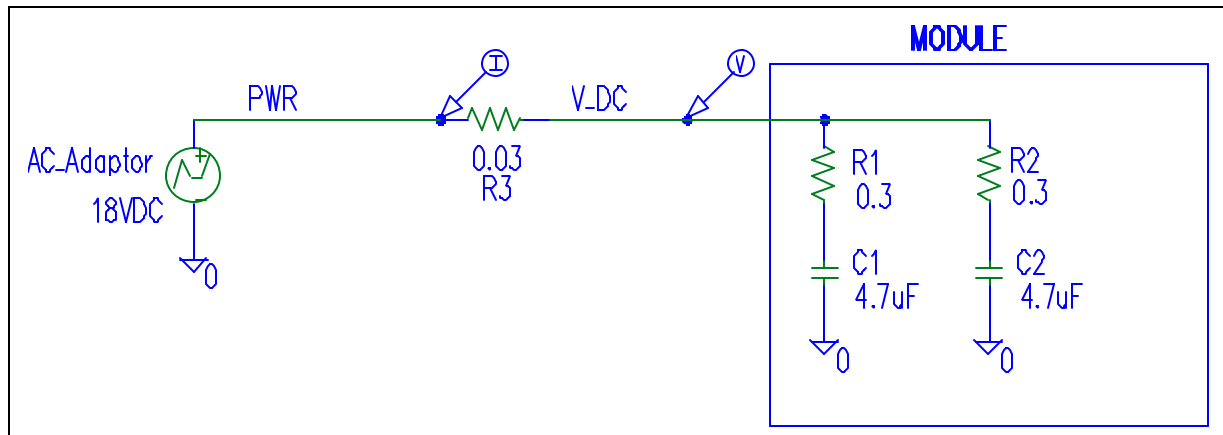

Figure 6. Instantaneous In-rush Current Model

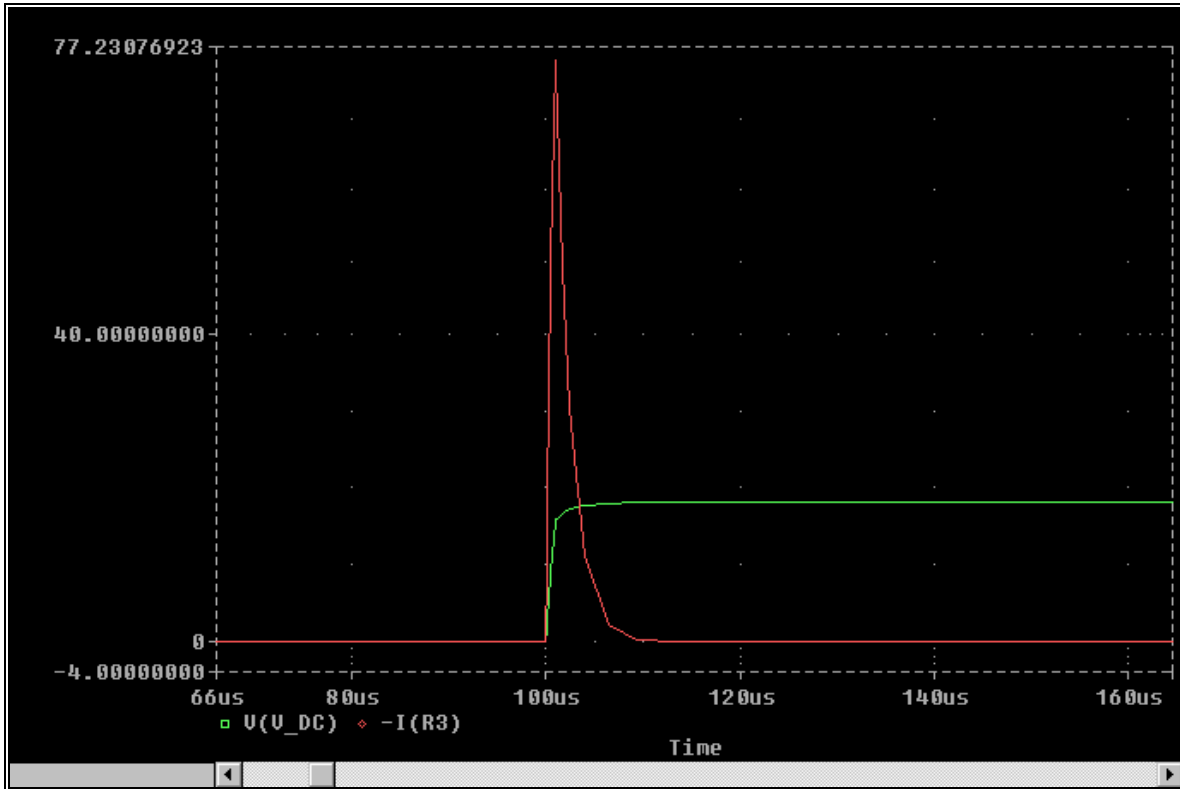
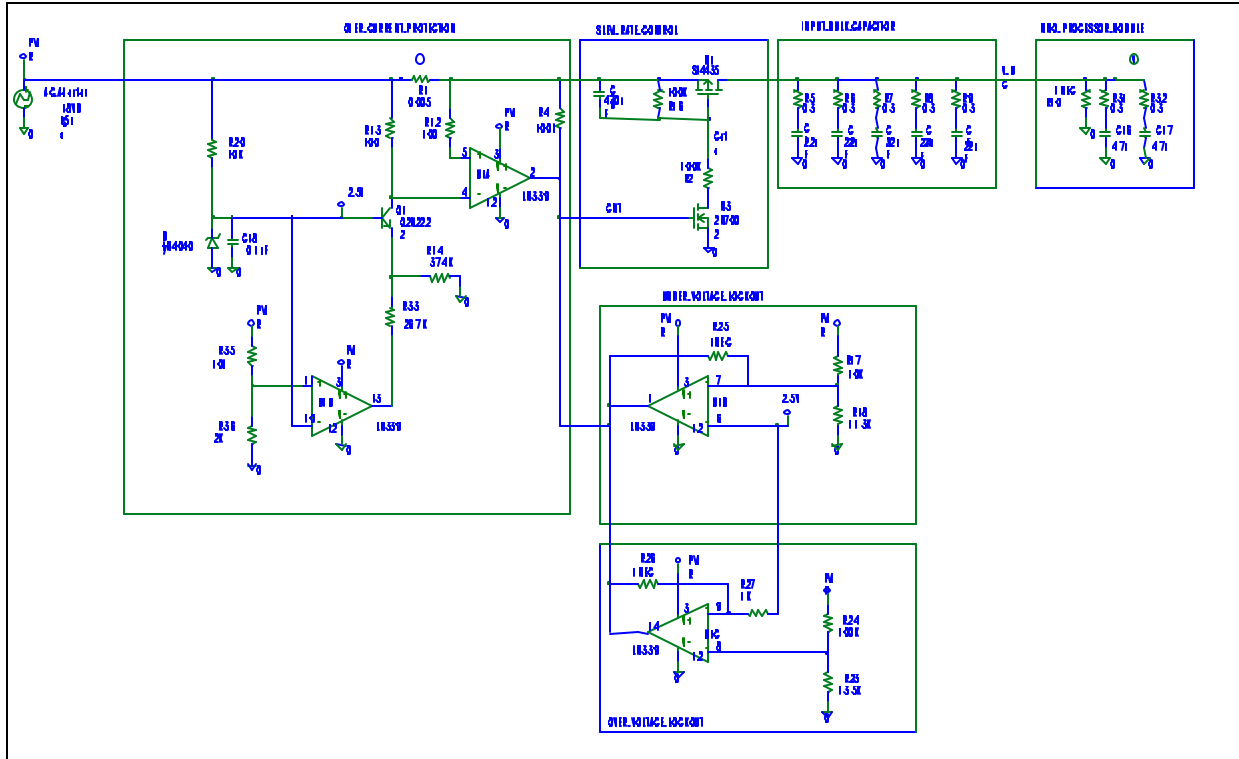

Figure 7. Instantaneous In-rush Current

Due to the stringent component height requirements of the Celeron processor mobile module, Polymerized Organic Semiconductor capacitors must be used as input bulk capacitance in the voltage regulator circuit. Because of the capacitor's susceptibility to high in-rush current, special care

must be taken. One way to soften the in-rush current and provide overvoltage and overcurrent protection is to ramp up  $V\_DC$  slowly using a circuit similar to the one shown in Figure 8.



NOTE:

Values shown are for reference only.

Figure 8. Overcurrent Protection Circuit

**4.7.4.1 Slew-rate Control: Circuit Description**

In Figure 8, PWR is the voltage generated by applying the AC Adaptor or Battery. M1 is a low  $R_{DS(on)}$  P-Channel MOSFET such as a Siliconix® SI4435DY. When the voltage-On PWR is applied and increased to over 4.75 volts, the

UNDER\_VOLTAGE\_LOCKOUT circuit allows R4 to pull up the gate of M3 to start a turn-on sequence. M3 pulls its drain toward ground, forcing current to flow through R2. M1 will not start to source any current until after  $t_{delay}$  with  $t_{delay}$  defined as:

$$t_{delay} := -R2 \cdot C9 \cdot \ln \left( 1 - \frac{Vt}{V_{pwr} - V_{gs\_max}} \right)$$

$$V_{gs\_max} = \frac{R16}{R16 + R2} \cdot V_{pwr}$$

The manufacturer's  $V_{gs\_max}$  specification of 20 volts must never be exceeded. However,  $V_{gs\_max}$  must be high enough to keep the  $R_{DS(on)}$  of the device as low as

possible. After the initial  $t_{delay}$ , M1 will begin to source current and  $V_{DC}$  will start to ramp up. The ramp up time,  $t_{ramp}$ , is defined as:

$$t_{ramp} := -R2 \cdot C9 \cdot \ln \left( 1 - \frac{V_{sat}}{V_{gs\_max}} \right) - t_{delay}$$

Maximum current during the voltage ramping is:

$$I = C_{total} \frac{V_{pwr}}{t_{ramp}}$$

As shown in the circuit in Figure 8:  $t_{delay} = 5.53$  ms;  $t_{tran} = 14.0$  ms; and  $I_{max} = 146$  mA.



Figure 9 shows a SPICE simulation of the circuit in Figure 8. To increase the reliability of the Tantalum capacitors, use a slew-rate control circuit as described in Figure 8 and voltage derate the capacitor about 50 percent. For example, for a maximum input voltage of 18 volts, use a 35-volt, low ESR capacitor with high ripple current capability. Place five, 22-microfarad/35-volt capacitors on the baseboard directly at the V<sub>DC</sub> pins of the connector. The slew-rate control circuit should also be applied to every input power source to the

system V<sub>DC</sub> to provide the most protection. If all power is logically “OR’ed” together at the PWR node, there is still a potential problem. For example, if a 3X3 Li-Ion battery pack is powering the system (12 volts at PWR), and the AC Adaptor (18 volts) is plugged into the system, it will immediately source current to the PWR node and V<sub>DC</sub> rapidly. This is because the slew-rate control is already ON. Therefore, the slew-rate control must be applied to every input power source to provide the most protection.

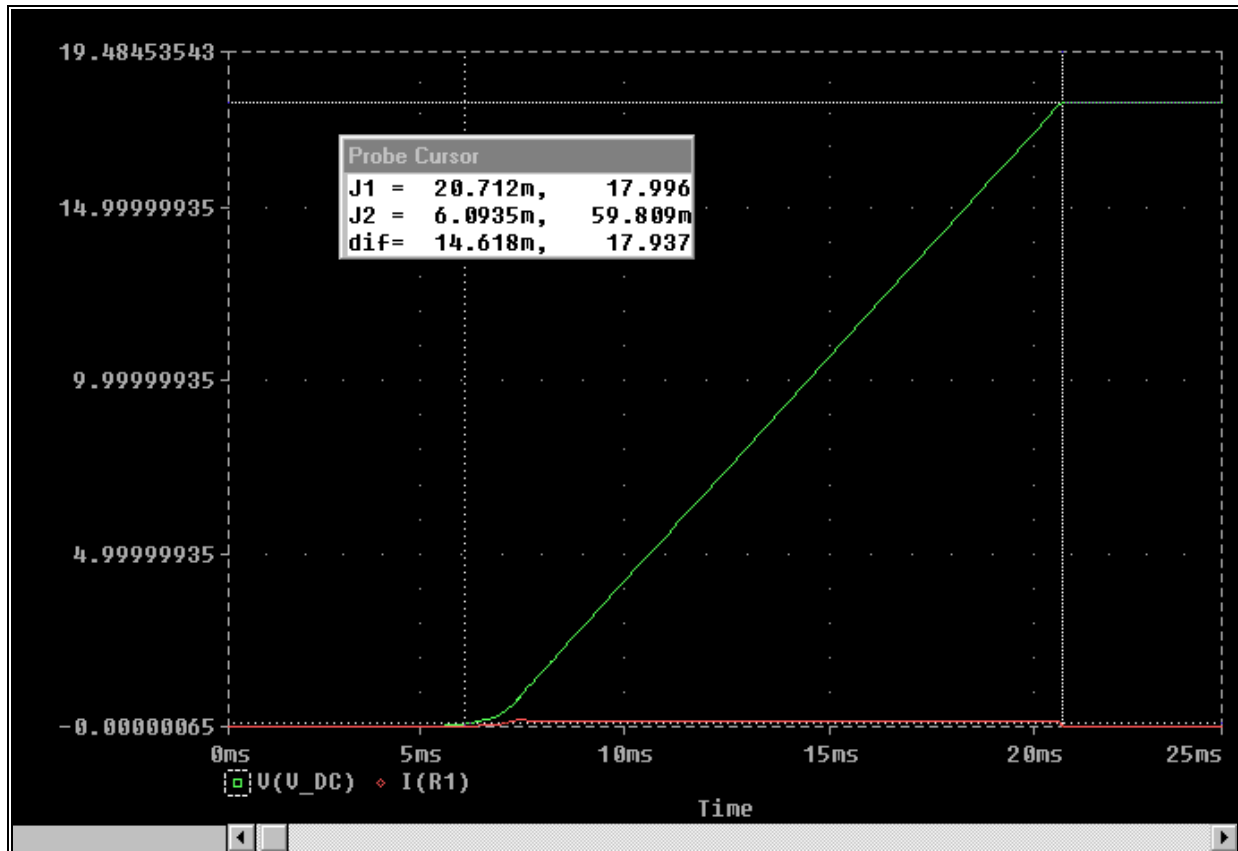

Figure 9. Spice Simulation Using In-rush Protection (Example Only)

#### 4.7.4.2 Undervoltage Lockout: Circuit Description (V<sub>uv\_lockout</sub>)

The circuit shown in Figure 8 provides an undervoltage protection and locks out the applied voltage to module to prevent an accidental turn-on at low voltage. The output of this circuit, pin 1 of the LM339 comparator, is an open-collector output. It is low when the applied voltage at PWR is

less than 4.75 volts. This voltage can be calculated with the following equation with the voltage across D7 as 2.5 volts (D7 is a 2.5-volt reference generator).

$$V_{uv\_lockout} := V_{ref} \left[ 1 + \frac{R17}{\left( \frac{R18 \cdot R25}{R18 + R25} \right)} \right]$$

$$V_{uv\_lockout} = 4.757 \text{ volts}$$

**4.7.4.3 Overvoltage Lockout: Circuit Description (V<sub>ov\_lockout</sub>)**

The Celeron processor mobile module MMC-1 operates with a maximum input voltage of 21 volts. This circuit locks out the input voltage if it exceeds the maximum

21 volts. The output of this circuit, Pin 14 of the LM339 comparator, is an open collector output. It is low when the applied voltage at PWR is more than 21 volts. This voltage can be calculated with the following equation:

$$V_{ov\_lockout} := V_{ref} \cdot \left( \frac{R26}{R26 + R27} \right) \cdot \left( 1 + \frac{R24}{R23} \right)$$

$$V_{ov\_lockout} = 20.998 \cdot \text{volt}$$

**4.7.4.4 Overcurrent Protection: Circuit Description**

Figure 8 shows that the circuit detects an overcurrent condition and cuts off the input voltage applied to the Celeron processor mobile module. This circuit has two different current limit trip points. This takes into account the different maximum current drain by the Celeron processor

mobile module at different input voltages. Assuming the AC Adaptor voltage is 18 volts and the battery is a 3x3 Li-Ion configuration with a minimum of 7.5 volts, the maximum current for the above circuit can be calculated using the following expression:

With AC Adaptor (I<sub>wAdaptor</sub>):

$$I_{wAdaptor} := \frac{V_{ref} - V_{be\_Q1}}{R14} \cdot \frac{R13}{R1}$$

$$I_{wAdaptor} = 0.989 \cdot \text{amp}$$

Without AC Adaptor (I<sub>woAdaptor</sub>):

$$I_{woAdaptor} := \frac{V_{ref} - V_{be\_Q1}}{\left( \frac{R14 \cdot R33}{R14 + R33} \right)} \cdot \frac{R13}{R1}$$

$$I_{woAdaptor} = 2.375 \cdot \text{amp}$$

**4.8 Active Thermal Feedback**

Table 22 identifies the addresses allocated for the SMBus thermal sensor.

**Table 22. Thermal Sensor SMBus Address Table**

Function	SMBus Address
Thermal Sensor	1001 110

NOTE:

The thermal sensor used is compliant with SMBus addressing. Please refer to the *Pentium® II processor Thermal Sensor Interface Specification*.



### 5.1.1 MMC-1 Connector Pin 1 Location

Figure 11 shows the location of pin 1 of the connector as referenced to the adjacent mounting hole.

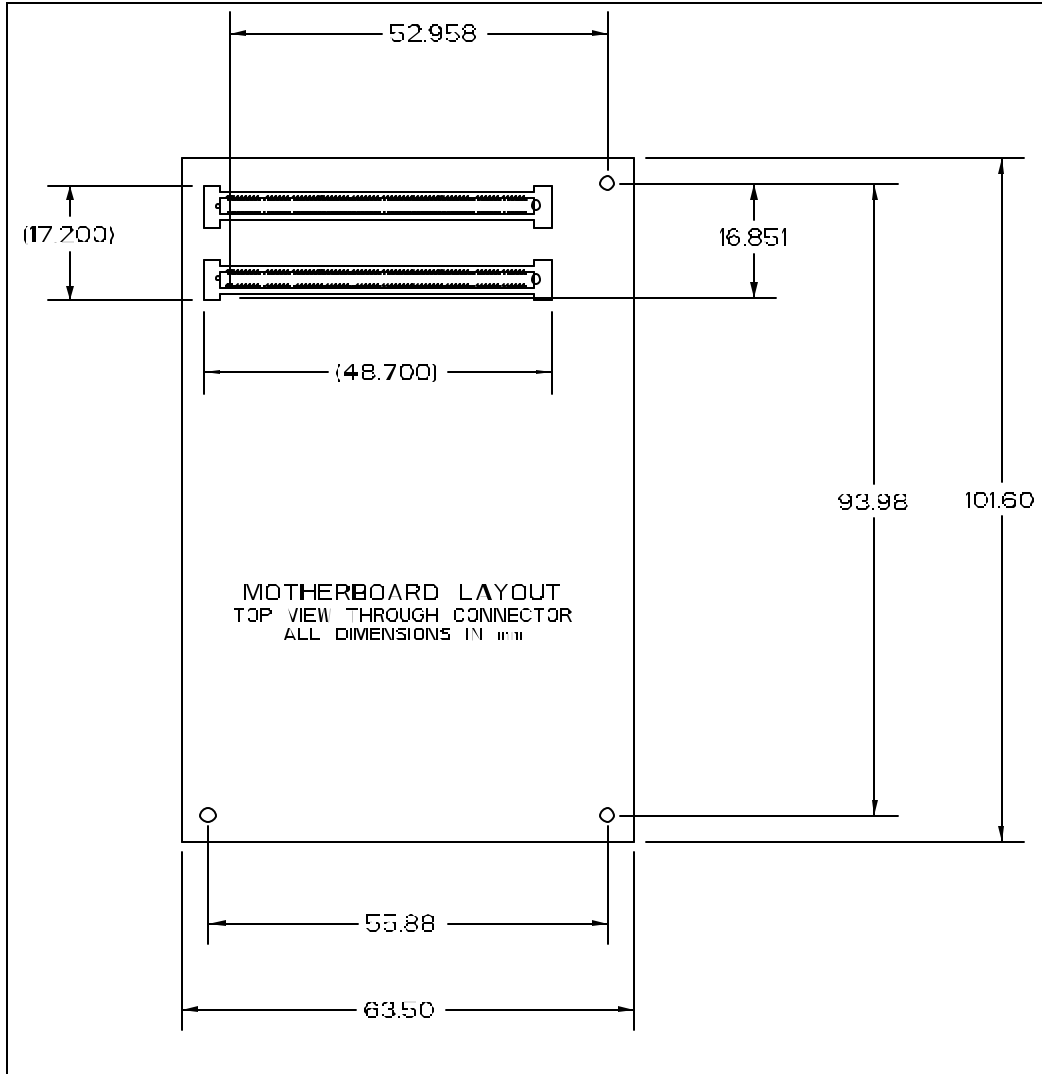

Figure 11. Celeron Processor Mobile Module MMC-1 Board Dimensions- Pin 1 Orientation

### 5.1.2 Printed Circuit Board Thickness

Figure 12 shows the minimum and maximum thickness of the printed circuit board (PCB). The range of PCB thickness allows for the use of different PCB technologies with current and future Intel mobile modules.

**Note:** Ensure that the mechanical restraining method or system-level EMI contacts are able to support this range of PCB thickness for compatibility with future Intel mobile modules.

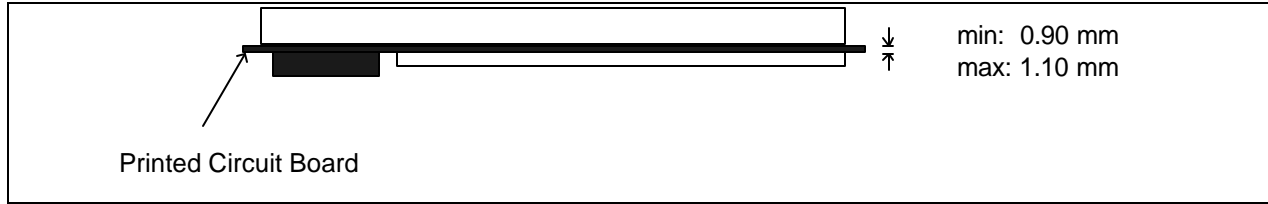

Figure 12. Printed Circuit Board Thickness

5.1.3 Height Restrictions

Figure 13 shows the mechanical stack-up and the associated component clearance requirements. This is referred to as the module keep-out zone and should not be entered or altered.

The system manufacturer establishes the board-to-board clearance between the module and the system electronics

by selecting one of three possible mating connectors. The mating connector sizes are 4 millimeters, 6 millimeters, or 8 millimeters. These three options provide the system manufacturer with flexibility in choosing components between the two boards. Information on these connectors can be obtained from your local Intel representative.

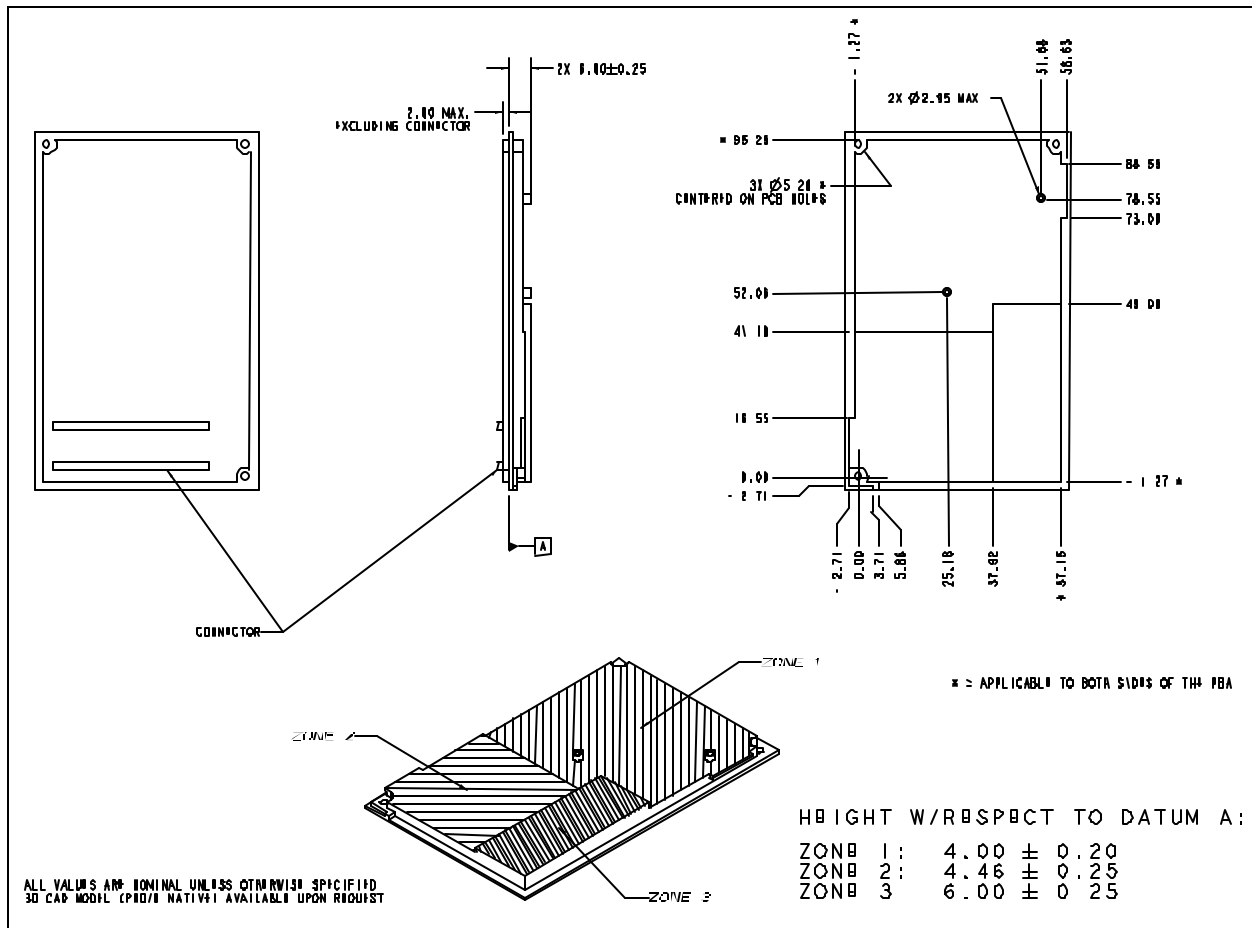

NOTE:  
The topside component clearance is independent of the PCB thickness.

Figure 13. Keep-out Zone

## 5.2 Thermal Transfer Plate

The TTP on the CPU and the 82433BX provides heat dissipation and a thermal attach point where a system manufacturer can attach a heat pipe, a heat spreader plate, or a thermal solution to transfer heat through the notebook system. See Figure 14 and Figure 15 for attachment dimensions from the thermal interface block to the TTP.

When attaching the mating block to the TTP, a thermal elastimer or thermal grease should be used. This material reduces the thermal resistance. The thermal interface block should be secured with 2.0-millimeter screws using a maximum torque of 1.5 Kg\*cm to 2.0 Kg\*cm (equivalent to

0.147 N\*m to 1.97 N\*m). The thread length of the 2.00-millimeter screws should be 2.25-millimeter gageable thread (2.25-millimeters minimum to 2.80-millimeters maximum).

The system manufacturer should use the exact dimensions for maximum contact area to the TTP to ensure that no warpage of the TTP occurs. If warpage occurs, the thermal resistance of the module could be adversely affected.

The TTP thermal resistance between the processor core to the system interface (top of the TTP) is less than 1 Celsius per watt.

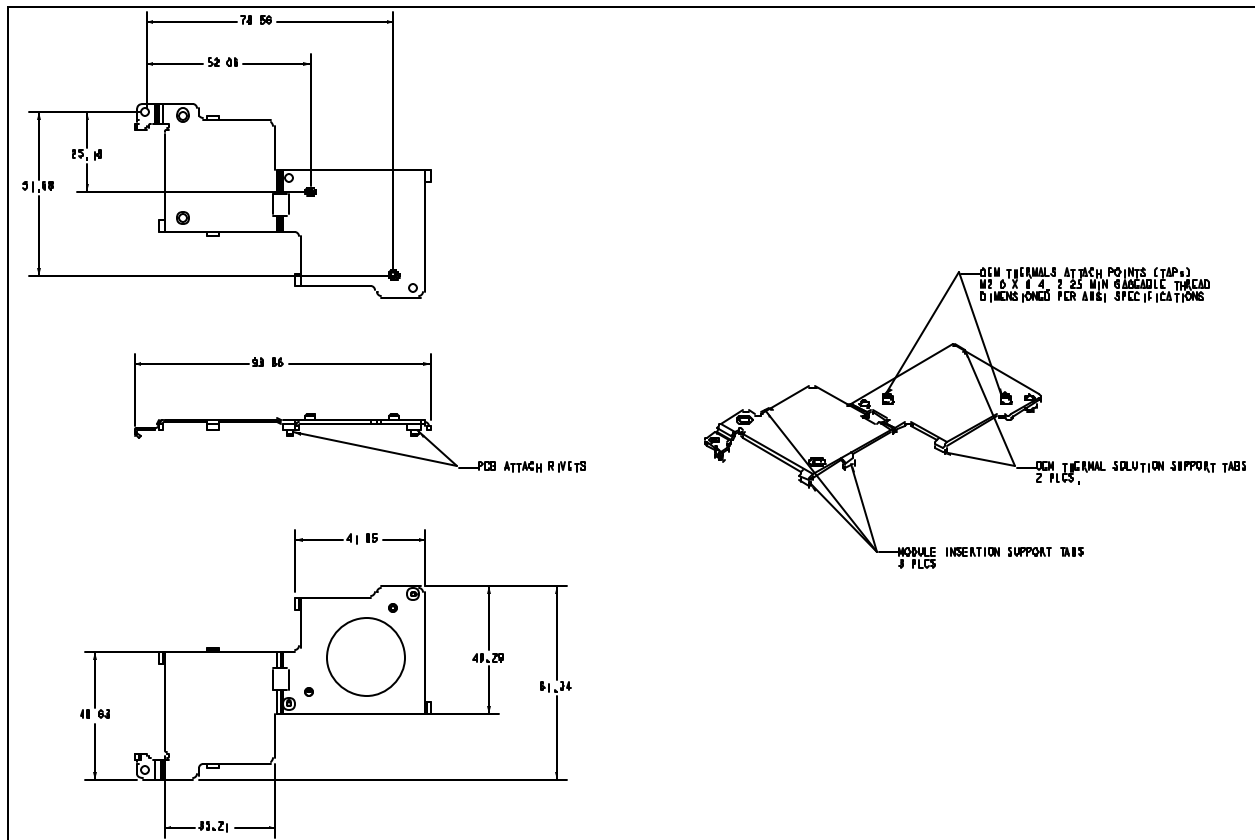

Figure 14. Thermal Transfer Plate (A)

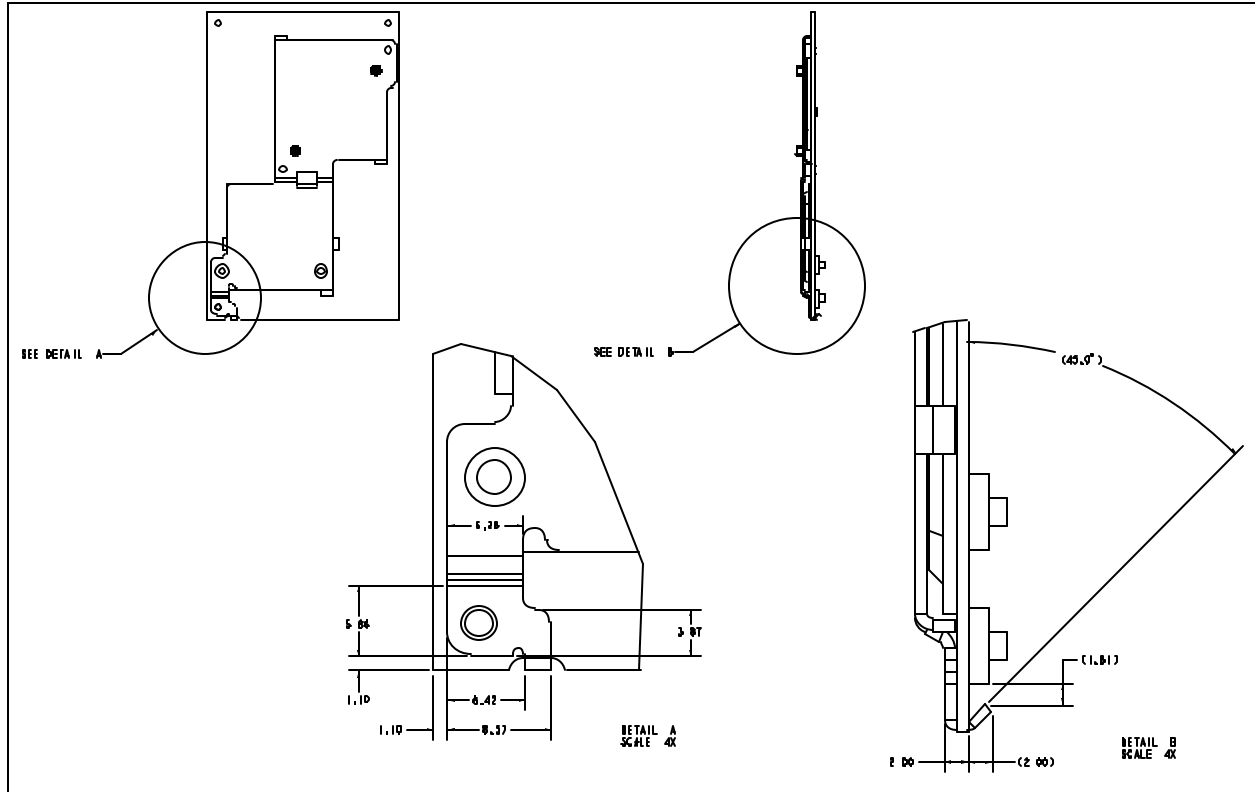

Figure 15. Thermal Transfer Plate (B)

### 5.3 Physical Support

#### 5.3.1 Mounting Requirements

Three mounting holes are available for securing the module to the system base. See Figure 11 for mounting hole locations. These hole locations and board edge clearances will remain fixed for all Intel mobile modules. Intel recommends that all three mounting holes are used to ensure long term mechanical reliability and EMI integrity of the system.

The board edge clearance includes a 0.762 millimeters (0.030 inches) wide EMI containment ring around the perimeter of the module. This ring is on each layer of the module PCB and is grounded. On the surface of the module, the metal is exposed for EMI shielding purposes. The hole

patterns placed on the module also have a plated surrounding ring, which can be used with a metal standoff for EMI shielding purposes. Standoffs should be used to provide support for the installed Celeron processor mobile module. The distance from the bottom of the module PCB to the top of the OEM system electronics board with the connectors mated is 4.0 millimeters +0.16 millimeters / -0.13 millimeters. However the warpage of the baseboard can vary and should be calculated into the final dimensions of the standoffs used. All calculations can be made with the *Intel® MMC-1 Standoff/Receptacle Height Spreadsheet*. Information on this spreadsheet can be obtained from your local Intel representative. Figure 16 shows the standoff support hole patterns, the board edge clearance, the dimensions of the EMI containment ring, and the keep-out area.

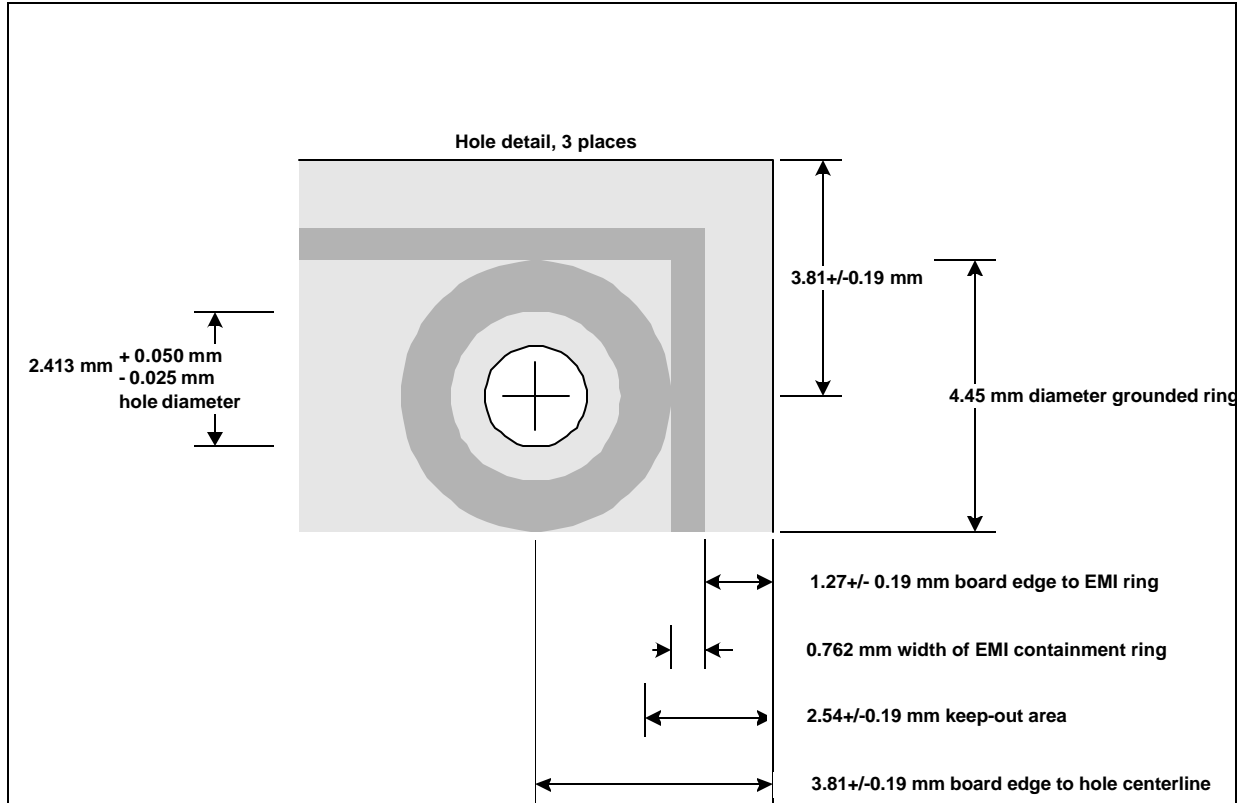

Figure 16. Standoff Holes, Board Edge Clearance, and EMI Containment Ring (Topside)

### 5.3.2 Module Weight

The Celeron processor mobile module MMC-1 weighs approximately 50 grams.

implementation of firmware/software control or “throttling” that reduces CPU power consumption and dissipation. This includes the power dissipated by *all* of the relevant components. During all operating environments, the processor junction temperature,  $T_j$ , must be within the range of 0 Celsius to 100 Celsius.

## 6.0 THERMAL SPECIFICATION

### 6.2 Thermal Sensor Setpoint

### 6.1 Thermal Design Power

The typical TDP is the typical total power dissipation under normal operating conditions at nominal  $V_{CORE}$  (CPU power supply) while executing the worst case power instruction mix. The power handling capability of the system thermal solution may be reduced less than the recommended typical thermal design power with the

The thermal sensor implements the SMBALERT# signal described in the SMBus specification. SMBALERT# is always asserted when the temperature of the processor core thermal diode or the thermal sensor internal temperature exceeds either the upper or lower temperature thresholds. SMBALERT# may also be asserted if the measured temperature equals either the upper or the lower threshold.

Table 24. Thermal Design Power Specifications

Symbol	Parameter	Typical	Notes
$TDP_{module}$	Thermal Design Power	11.5 W	Module = core, 82443DX, and voltage regulator.

**NOTE:**

1. During all operating environments, the processor temperature,  $T_j$  must be within the specified range of 0 Celsius to 100 Celsius.
2.  $TDP_{module}$  is a thermal solution design reference point for OEM thermal solution readiness for total module power.



## 7.0 LABELING INFORMATION

The Celeron processor mobile module MMC-1 is tracked in two ways. The first is by the Product Tracking Code (PTC). Intel uses the PTC label to determine the assembly level of

the module. The PTC label is on the secondary side of the module as shown in Figure 17. The PTC consists of 13 characters and contains the following information:

Example: **PMH3661001AA**

Definition:	AA	-	Processor Module = PM
	B	-	Celeron processor mobile module MMC-1= H
	CCC	-	Speed Identity = 266, 300, 333, 366, 400
	DD	-	Cache Size = 01 (128K)
	EEE	-	Notifiable Design Revision (Start at 001)
	FF	-	Notifiable Processor Revision (Start at AA)

Note: For other Intel mobile modules, the second field (B) is defined as:  
Celeron processor mobile module (MMC-2) = I

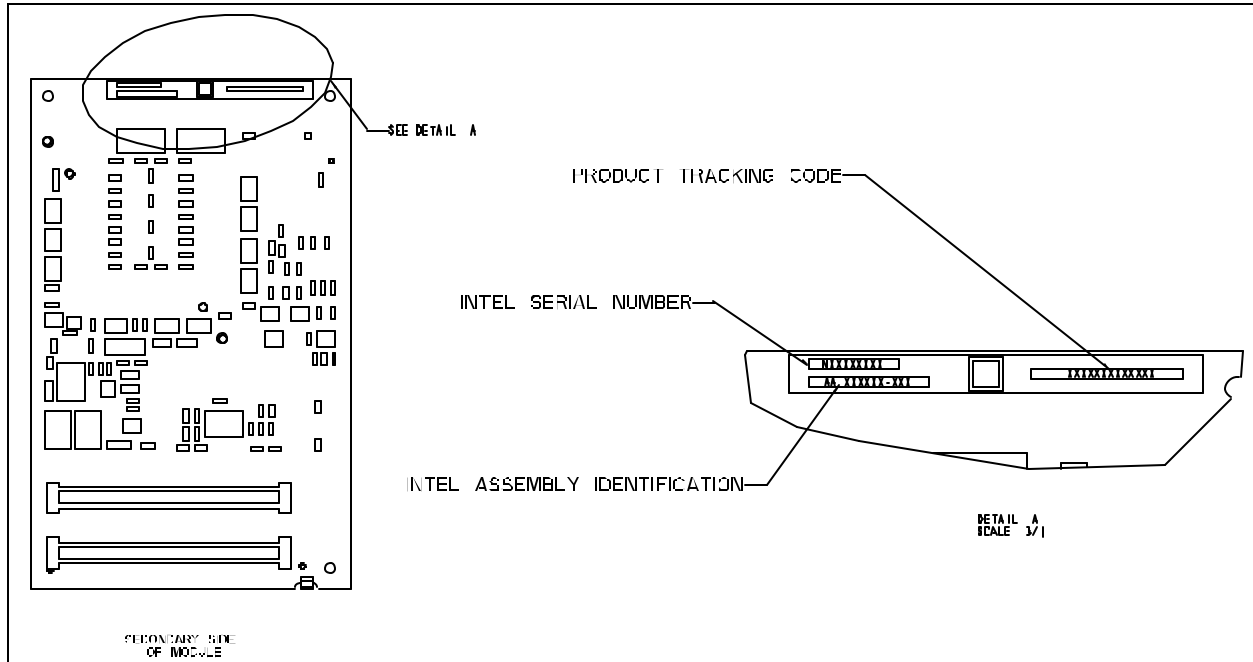

Figure 17. Product Tracking Code

The second tracking method is by an OEM generated software utility. Four strapping resistors located on the Celeron processor mobile module MMC-1 determine its production level. If connected and terminated properly, up to 16 module- revision levels can be determined. An OEM generated software utility can then read these ID bits with CPU IDs and stepping IDs to provide a complete module manufacturing

revision level. For current PTC and module ID bit information, please refer to the latest Product Change Notification letter, which can be obtained from your local Intel sales representative.

## 8.0 ENVIRONMENTAL STANDARDS

The environmental standards for the Celeron processor mobile module MMC-1 are defined in Table 25.

**Table 25. Environmental Standards**

Parameter	Condition	Specification
Temperature Cycle	Non-operating	-40°C to 85°C
	Operating	0°C to 55°C
Humidity	Unbiased	85% relative humidity at 55 °C
Voltage	V <sub>5</sub>	5V +/- 5%
	V <sub>3</sub>	3.3V +/- 5%
Shock	Non-operating	Half Sine, 2G, 11 msec
	Unpackaged	Trapezoidal, 50G, 11 msec
	Packaged	Inclined Impact at 5.7 ft/s
	Packaged	Half Sine, 2 msec at 36 in. Simulated Free Fall
Vibration	Unpackaged	5 Hz to 500 Hz 2.2 gRMS random
	Packaged	10 Hz to 500 Hz 1.0 gRMS
	Packaged	11,800 impacts 2 Hz to 5 Hz (low frequency)
ESD Damage	Human Body Model	Non-powered test of the module only for non-catastrophic failure. The module is tested at 2 KV and then inserted in a system for a functional test.