



STA2058

TESEO™

GPS platform high-sensitivity baseband

Data Brief

Features

- Single chip baseband with embedded Flash
- Complete embedded memory system:
 - Flash 256 KB +16 Kbytes
 - RAM 64 Kbytes
- 66 MHz ARM7TDMI 32 bit processor
- High performance GPS engine (HPGPS)
- SBAS (WAAS and EGNOS) supported
- Sensitivity (-146 dBm acquisition, -159 dBm tracking)
- Time to first fix (1s reacquisition, 2.5 s hot start, 34 s warm start, 39 s cold start)
- Accuracy (2 m autonomous)
- External memory interface (EMI) supporting up to 64 Mbyte of external SRAM, Flash and ROM
- Extensive GPS receiver interfaces:
48 GPIOs, 4 UARTs, 2 SPIs, 2 I2Cs,
2 CANs 2.0, 1 USB 1.1, 1 HDLC and 4 channels ADC
- ST proprietary Flash embedded technology
- LFBGA144 and LQFP64 lead-free package
- -40 °C to 85 °C operating temperature range

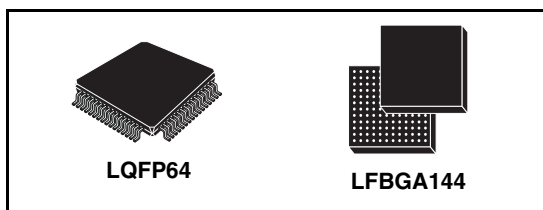

Evaluation kits

- STA2058 module reference design (25x25mm)
- Evaluation board hosting STA2058 module
- SDK board (for application SW development)

Description

STA2058 is the high-sensitivity baseband of TESEO GPS platform which include the STA5620 RF Front-End.

The embedded Flash memory enables the equipment manufacturer to load the entire GPS software (including tracking, acquisition, navigation and data output) after customizing its interfaces to his needs. A standard GPS library is available from ST.

TESEO is the ideal solution for consumer, handheld, PND (portable navigation), in vehicle navigation and telematics systems.

SBAS (WAAS and EGNOS) feature is also supported.

Table 1. Device summary

Order code	Package	EMI (External Memory Interface)	Packing	Automotive grade
STA2058	LQFP64 (10x10x1.4mm)	No	Tray	No
STA2058TR	LQFP64 (10x10x1.4mm)	No	Tape and reel	No
STA2058EX	LFBGA144 (10x10x1.7mm)	Yes	Tray	No
STA2058EXTR	LFBGA144 (10x10x1.7mm)	Yes	Tape and reel	No
STA2058EXA	LFBGA144 (10x10x1.7mm)	Yes	Tray	Yes
STA2058EXATR	LFBGA144 (10x10x1.7mm)	Yes	Tape and reel	Yes

Contents

1	Features summary	3
2	Pin description	5
	2.1 Logic symbol	5
3	System block diagram	6
	3.1 Package LFBGA144	8
	3.2 Package LQFP64	9
	3.3 Power supply pins	10
4	Electrical characteristic	11
	4.1 DC electrical characteristic	11
	4.2 AC electrical characteristics	12
	4.3 nRSTIN input filter characteristics	12
	4.4 Flash electrical characteristics	13
	4.5 Oscillator electrical characteristics	14
	4.6 ADC electrical characteristics	14
	4.7 PLL electrical characteristics	15
	4.8 LVD electrical characteristics	15
	4.9 GPS performances	16
5	Package information	17
6	Revision history	19

1 Features summary

- ARM7TDMI 16/32 bit RISC CPU based host microcontroller running at a frequency up to 66 MHz.
- Complete embedded memory system:
 - Flash 256 Kbytes + 16 Kbytes (100 KB erasing/programming cycles)
 - RAM 64 Kbytes.
- External memory interface provides glueless support for up to four banks of external SRAM, Flash, ROM.
- High performance GPS engine (HPGPS).
- ST Proprietary CMOS (0.18 μm) Flash embedded technology.
- SBAS (WAAS and EGNOS) supported
- -40 °C to 85 °C operating temperature range.
- 144-pin LFBGA package and 64-pin LQFP package
- Power supply:
 - 3.0 V to 3.6 V operating supply range for Input/Output periphery
 - 3.0 V to 3.6 V operating supply range for A/D Converter reference
 - 1.8 V operating supply range for core supply provided either by internal voltage regulator (with external stabilization capacitor) or by external supply voltage.
- Reset and clock control unit able to provide low power modes (WAIT, SLOW, STOP, STANDBY) and to generate the internal clock from the external reference through integrated PLL.
- 48 programmable general purpose I/O, each pin programmable independently as digital input or digital output; 40 (30 in LQFP64) are multiplexed with peripheral functions; 16 can generate an interrupt on input level/transition.
- Real time clock module with 32 kHz low power oscillator and separate power supply to continue running during standby mode.
- 16-bit Watchdog timer with 8 bits prescaler for system reliability and integrity.
- 2 CAN modules compliant with the CAN specification V2.0 part B (active) and bit rate can be programmed up to 1 Mbaud. One additional CAN at 1 Mbps (for STA2058 EM SIP version)
- Four 16-bit programmable timers with 7 bit prescaler, up to two input capture/output compare, one pulse counter function, one PWM channel with selectable frequency each.
- 4 channels 12-bit sigma-delta analog to digital converter, single channel or multi channel conversion modes, single-shot or continuous conversion modes, sample rate 1 kHz, conversion range 0-2.5 V .
- Three serial communication interfaces (UART) allow full duplex, asynchronous, communications with external devices, independently programmable TX and RX baud rates up to 625 Kbaud.
- One UART adapted to suit smart card interface needs, for asynchronous SC as defined by ISO 7816-3. It includes SC clock generation.
- Two serial peripheral interfaces (SPI) allow full duplex, synchronous communications with external devices, master or slave operation, max baud rate of 5.5 Mb/s. One SPI may be used as multimedia card interface.

- Two I²C Interfaces provide multi-master and slave functions, support normal and fast I²C mode (400 KHz), 7/10 bit addressing modes. One I²C Interface is multiplexed with one SPI, so either 2 x SPI + 1 x I²C or 1 x SPI + 2 x I²C may be used at a time.
- Enhanced interrupt controller supports 32 interrupt vectors, independently maskable, with interrupt vector table for faster response and 16 priority levels, software programmable for each source. Up to 2 maskable interrupts may be mapped on FIQ.
- Wakeup unit allows exiting from power down modes by detection of an event on two external pins (one is active high and other is active low) or on internal real time clock alarm.
- USB unit V1.1 compliant, software configurable endpoint setting, USB suspend/resume support
- High level data link controller (HDLC) unit supports full duplex operating mode, NRZ, NRZI, FM0 and MANCHESTER modes, and internal 8-bit baud rate generator.

2 Pin description

2.1 Logic symbol

Figure 1. STA2058 TESEO symbol

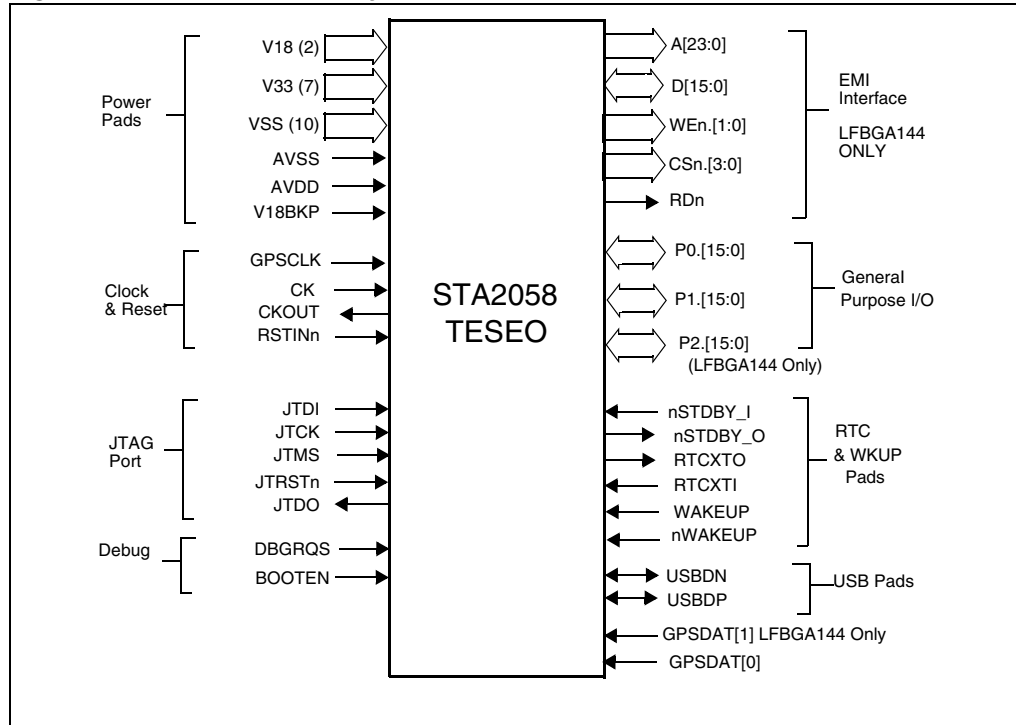

3 System block diagram

Figure 2. STA2058 TESEO block diagram

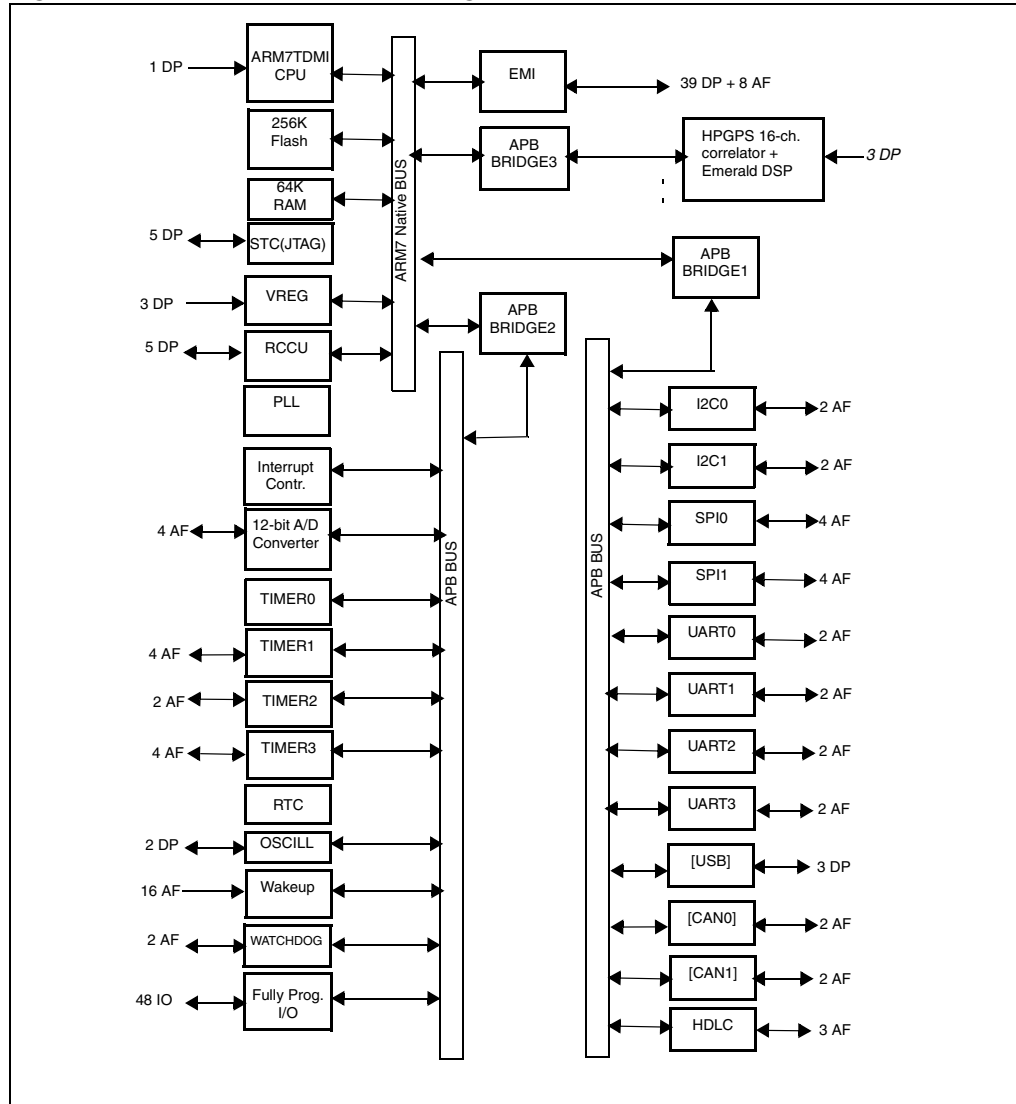
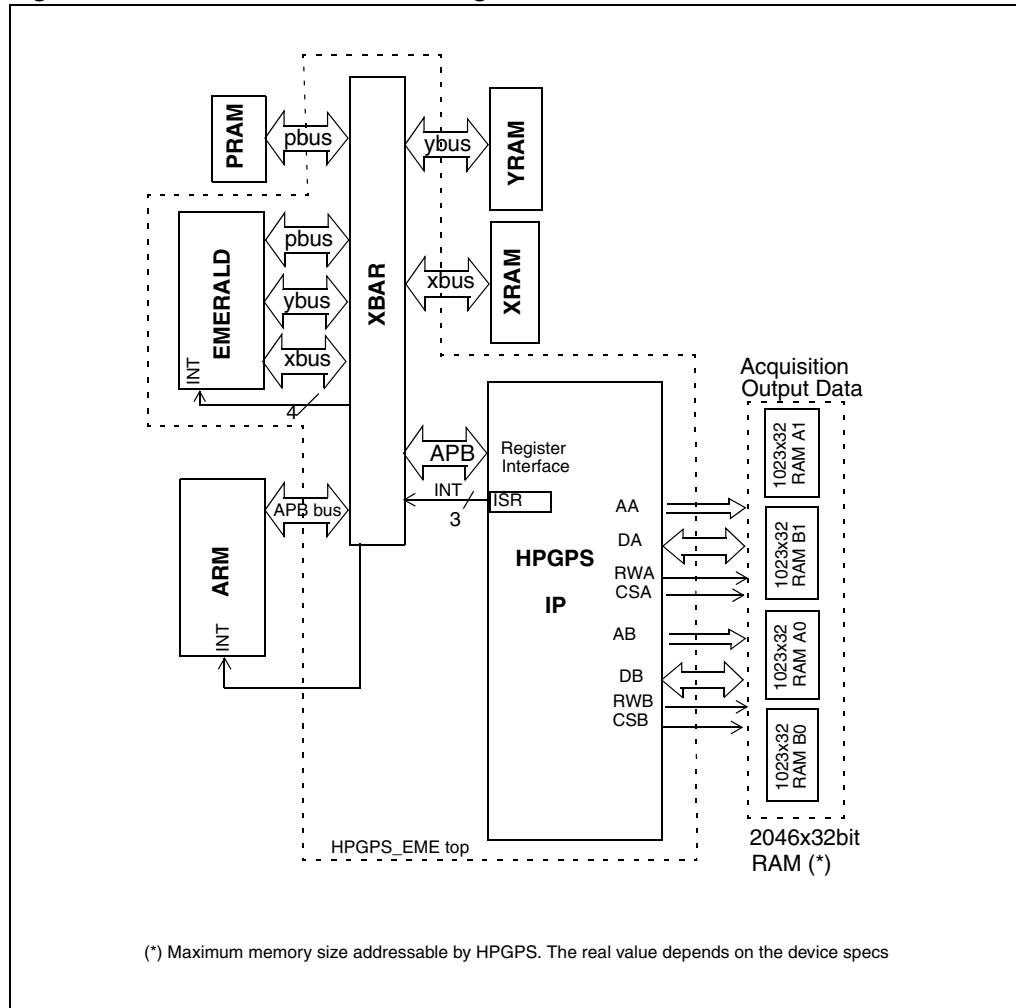

Figure 3. New HPGPS 16-ch including Emerald DSP 16-bit



3.1 Package LFBGA144

Table 2. Ball out for LFBGA144 package

	A	B	C	D	E	F	G	H	J	K	L	M
1	P0.10/ U1.RX/ U1.TX	P2.0/ CSn.0	P2.1/ CSn.1	VSS	P2.2/ CSn.2	P2.6/ A.22	BOOTEN	P2.12	P2.13	P2.15	JTDI	NC
2	VSS	RDN	P0.11/ U1.TX/ BOOT.1	V33	P2.3/ CSn.3	P2.8	P2.9/ CAN1_TX	JTMS	JTRSTn	GPSCCLK	GPSDAT1	V33REG_B KP
3	V33	P0.9/ U0.TX/ BOOT.0	P0.12/ SCCLK	P0.13/ U2.RX/ T2.OCMP A	P2.4/ A.20	NC	P2.10/ CAN1_RX	JTCK	GPSDAT0	V33	VSSREG	DBGRQS
4	P0.6/ S1.SCLK	P0.7/ S1.SSN	P0.8/ U0.RX/U0. TX	P0.14/ U2.TX/ T2.ICAPA	P2.5/ A.21	VSS	P2.11	JTDO	CK	CKOUT	VSS	VSS
5	A.19	WEn.1	WEn.0	P0.5/ S1.MOSI	P2.7/ A.23	VSS	P2.14	NC	RTCXTO	RTCXTI	WAKEUP_ PA	P0.15/ WAKEUP
6	P0.3/ S0.SSN/ I1.SDA	A.15	A.16	A.17	A.18	V33	V18	V18	V18BKP	V18BKP	VSSBKP	nSTDBY_IN
7	P0.2/ S0.SCLK/ I1.SCL	P0.1/ S0.MOSI/ U3.RX	P0.4/ S1.MISO	VSS	V18	A.14	D.12	D.1	D.0	nSTDBY_ O	VSS18	RSTINn
8	A.9	A.10	A.11	A.13	P0.0/ S0.MISO/ U3.TX	A.0	D.11	P1.12/ CANTX	AVSS	AVSS	D.3	D.2
9	VSS18	V33	A.5	A.6	V33	D.15	D.10	P1.8/ PPS	D.9	P1.0/ T3.OCMP B/ AIN.0	NC	AVDD
10	A.8	V33	P1.15/ HTXD	P1.13/ HCLK/ I0.SCL	VSS	D.14	USBDN	P1.7/ T1.OCMP B	D.8	P1.5/ T1.ICAPB	P1.1/ T3.ICAPA/ AIN.1	D.4
11	A.7	NC	P1.14/ HRXD/ I0.SDA	P1.10/ USBCLK	A.2	D.13	USBDP	VSSIO- PLL	D.5	P1.4/ T1.ICAPA	P1.3/ T3.ICAPB/ AIN.3	AVDD
12	A.12	A.4	A.3	P1.9/ PRN.11	A.1	P1.11/ CANRX	NC	V33IO-PLL	P1.6/ T1.OCMPA	D.7	D.6	P1.2/ T3.OCMPA/ AIN.2

3.2 Package LQFP64

Figure 4. LQFP64 package outline

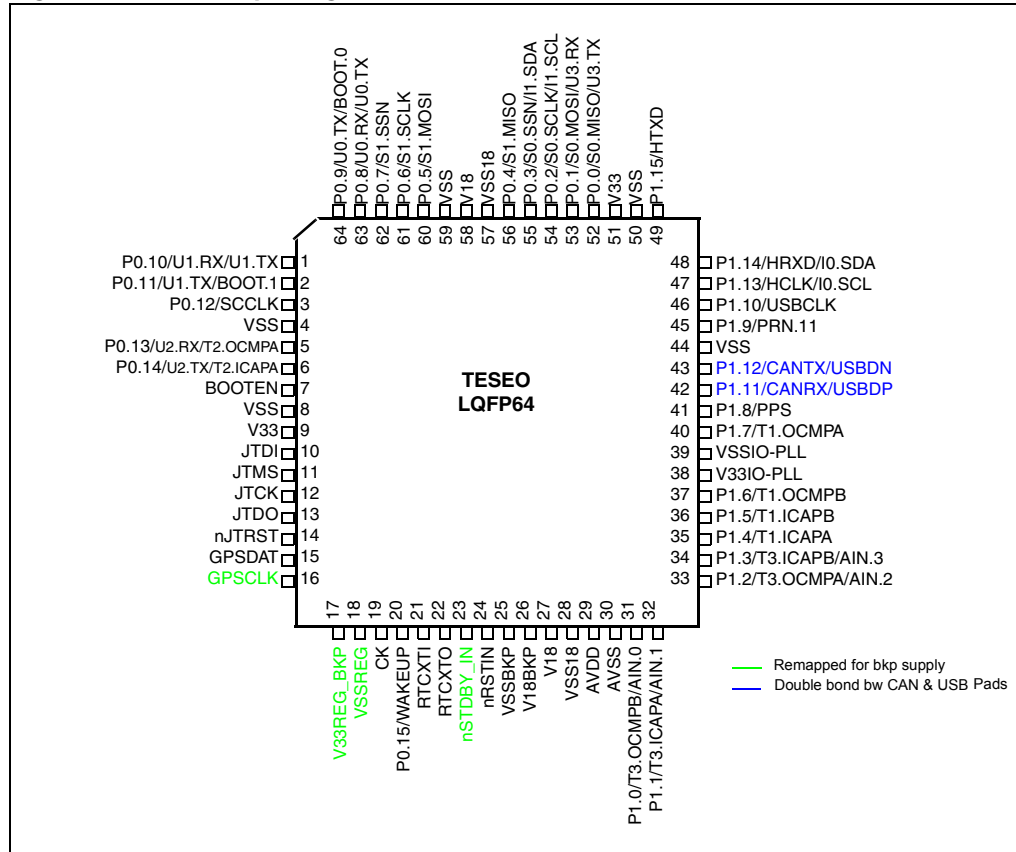

3.3 Power supply pins

Table 3. Power supply pins

Symbol	I/O	Function	LQFP 64	LFBGA144
V ₃₃	-	Digital supply voltage for I/O circuitry (3.3 Volt)	9, 51	D2,A3,K3,F6,B9, E9,B10
V _{SS}	-	Digital ground for I/O circuitry	4, 8, 44, 50, 59	D1,A2,F4,L4,M4, F5, D7,E10
V _{33IO-PLL}	-	Digital supply voltage for I/O circuitry and for PLL reference (3.3V)	38	H12
V _{SSIO-PLL}	-	Digital ground for I/O circuitry and for PLL reference	39	H11
V _{33REG_BKP}	-	Digital supply voltage for backup block I/O circuitry and for ballast I/O (3.3V)	17	M2
V _{SSREG}	-	Digital ground for ballast I/O	18	L3
V ₁₈	-	Digital supply voltage for core circuitry (1.8 Volt): when using the internal voltage regulator, this pin shall not be driven by an external voltage supply, but a capacitance of at least 10μF (tantalum, low series resistance) + 33nF (ceramic) shall be connected between these pins and V _{SS18} to guarantee on-chip voltage stability.	27, 58	G6, H6,E7
V _{SS18}	-	Digital Ground for core circuitry	28, 57	A9,L7
V _{18BKP}	-	Digital supply voltage for backup block (RTC, oscillator, Wake-up controller - 1.8 Volt): when using the internal voltage regulator, this pin shall not be driven by an external voltage supply, but a capacitance of at least 1μF shall be connected between this pin and V _{SSBKP} to guarantee on-chip voltage stability.	26	J6,K6
V _{SSBKP}	-	Digital Ground for backup logic	25	L6
AV _{DD}	-	Analog supply voltage for the A/D converter	29	M9, M11
AV _{SS}	-	Analog supply Ground for the A/D converter	30	J8,K8

Note: V₃₃ and V_{33IO-PLL} are all internally connected. Same for V_{SS} and V_{SSIO-PLL}.

All V_{SS}, V_{SS18}, V_{SSBKP}, AV_{SS} pins must be tied together to the common ground plane, taking care of noise filtering, especially on AV_{SS}

4 Electrical characteristic

4.1 DC electrical characteristic

$V_{33} = 3.3 \text{ V} \pm 10 \%$, $T_A = -40 / 85 \text{ }^\circ\text{C}$ unless otherwise specified.

Table 4. DC electrical characteristic

Symbol	Parameter	Test conditions	Value			
			Min.	Typ.	Max.	Unit
V_{IH}	Input high level CMOS	With or w/o hysteresis	$0.7V_{33}$			V
	Input high level	P0.15 (WAKEUP) only	1.8			V
V_{IL}	Input low level CMOS	With or w/o hysteresis			$0.3V_{33}$	V
	Input low level	P0.15 (WAKEUP) only			0.7	V
V_{HYS}	Input hysteresis CMOS Schmitt trigger		0.4	0.8	1.2	V
	Input hysteresis Schmitt trigger	P0.15 (WAKEUP) only	0.3	0.5		V
V_{OH}	Output high level high current pins	Push Pull, $I_{OH} = 8\text{mA}$	$V_{33} - 0.8$			
	Output high level standard current pins	Push Pull, $I_{OH} = 4\text{mA}$	$V_{33} - 0.8$			
V_{OL}	Output low level standard current pins	Push Pull, $I_{OH} = 8\text{mA}$			0.4	V
		Push Pull, $I_{OH} = 4\text{mA}$			0.4	V
R_{WPU}	Weak pull-up resistor	Measured at $0.5V_{33}$		100		$\text{k}\Omega$
R_{WPD}	Weak pull-down resistor	Measured at $0.5V_{33}$		100		$\text{k}\Omega$

4.2 AC electrical characteristics

Table 5. AC electrical characteristics

$V_{33} = 3.3 \text{ V} \pm 10 \%$, $T_A = 27 \text{ }^\circ\text{C}$ unless otherwise specified.

Symbol	Mode	System clock	Value			Unit
			Min.	Typ.	Max.	
I_{DDRUN}	RUN mode	33 MHz system clock		60		mA
I_{DDWFI}	WFI mode	1 MHz system clock		5		mA
$I_{DDL P}$	LPWFI mode	32 kHz system clock		300		μA
I_{DDSTP}	STOP mode	Main VReg off, Flash in power-down		200		μA
I_{DDSB1}	STANDBY_1 mode	LP VReg and 32kHz Osc on		15	30	μA
I_{DDSB0}	STANDBY_0 mode	LP VReg, LVD, 32kHz Osc bypassed		3	10	μA

Note: I_{DDRUN} is the consumption in applications exploiting the full performances of the core. A typical GPS application would run at 33MHz, at the maximum frequency (66MHz) the power consumption is $I_{DDRUN} = 150 \text{ mA}$ (typ).

In WFI mode the VReg and Flash are ON to guarantees the minimum interrupt response time.

Table 6. AC electrical characteristics

$V_{33} = 3.3 \text{ V} \pm 10\%$, $T_A = -40 / 85 \text{ }^\circ\text{C}$ unless otherwise specified.

Symbol	Mode	System clock	Value			Unit
			Min.	Typ.	Max.	
F_{CPU}	CPU max frequency	Executing from RAM or EMI			66	MHz
F_{MAX}	Flash max frequency	Executing from Flash			60	MHz

4.3 nRSTIN input filter characteristics

$V_{33} = 3.3 \text{ V} \pm 10 \%$, $T_A = -40 / 85 \text{ }^\circ\text{C}$ unless otherwise specified.

Table 7. nRSTIN input filter characteristics

Symbol	Mode	System clock	Value			Unit
			Min.	Typ.	Max.	
t_{FR}	nRSTIN input filtered pulse				100	ns
t_{NFR}	nRSTIN input not filtered pulse		1.2			μs

4.4 Flash electrical characteristics

$V_{33} = 3.3 \pm 10\%$, $T_A = -40 / 85 \text{ }^\circ\text{C}$ unless otherwise specified.

Table 8. Flash program/erase characteristics 1

Symbol	Parameter	Test conditions	Value			Unit
			Typ	Max (C_0)	Max (C_{max})	
t_{PW}	Word program		40			μs
t_{PDW}	Double word program		60			μs
t_{PB0}	Bank 0 program (256K)	Double word program	1.6	2.1	4.3	s
t_{PB1}	Bank 1 program (16K)	Double word program	130	170	300	ms
t_{ES}	Sector erase (64K)	Not preprogrammed	2.3	4.0	4.9	s
		Preprogrammed	1.9	3.3	4.1	
t_{ES}	Sector erase (8K)	Not preprogrammed	0.7	1.1	1.36	s
		Preprogrammed	0.6	1.0	1.26	
t_{ES}	Bank 0 erase (256K)	Not preprogrammed	8.0	13.7	17.2	s
		Preprogrammed	6.6	11.2	14.0	
t_{ES}	Bank 1 erase (16K)	Not preprogrammed	0.9	1.5	1.87	s
		Preprogrammed	0.8	1.3	1.66	
t_{RPD}	Recovery from power-down			20	μs	
t_{PSL}	Program suspend latency			10	μs	
t_{ESL}	Erase suspend latency			300	μs	

Note: C_0 : $T_A = 85 \text{ }^\circ\text{C}$ after 0 cycles
 C_{max} : $T_A = 85 \text{ }^\circ\text{C}$ after max number of cycles

Table 9. Flash program/erase characteristics 2

Symbol	Parameter	Conditions	Value			Unit
			Min	Typ	Max	
	Endurance		10			Kcycles
	Endurance (Bank1 sectors)		100			Kcycles
	Data retention		20			Years
t_{ESR}	Erase suspend rate	Min time from erase resume to next erase suspend	20			ms

4.5 Oscillator electrical characteristics

$V_{33} = 3.3 \pm 10\%$, $T_A = -40 / 85\text{ }^\circ\text{C}$ unless otherwise specified.

Figure 5. Crystal oscillator and resonator

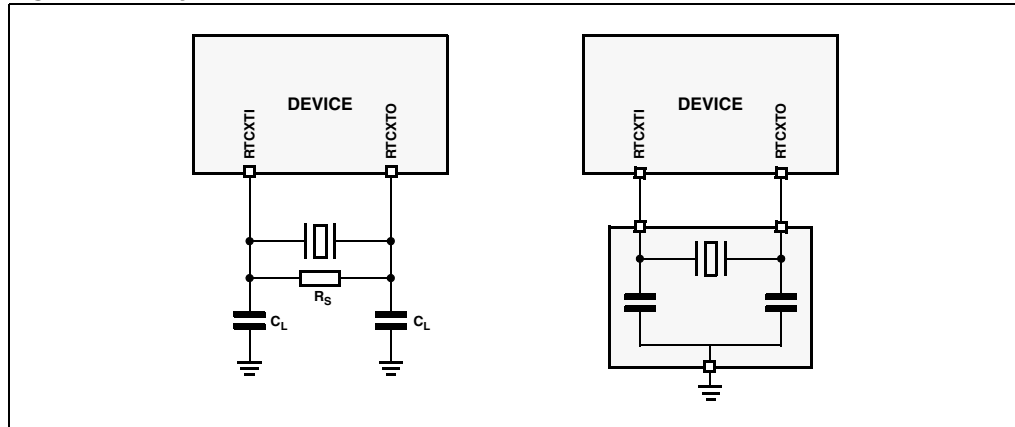

Table 10. Oscillator electrical characteristics

Symbol	Parameter	Test conditions	Value			Unit
			Min	Typ	Max	
g_m	Oscillator transconductance			8		$\mu\text{A/V}$
t_{STUP}	Oscillator startup time	Stable V_{DD}			2.5	s

4.6 ADC electrical characteristics

$V_{33} = 3.3 \pm 10\%$, $A_{\text{VDD}} = 3.3\text{V} \pm 10\%$, $T_A = -40 / 85\text{ }^\circ\text{C}$ unless otherwise specified.

Table 11. ADC electrical characteristics

Symbol	Parameter	Test conditions	Value			Unit
			Min	Typ	Max	
RES	Resolution	Sinewave with ΔV_{IN} amplitude		12		bits
ΔV_{IN}	Input voltage range		0		2.5	V
F_{Mod}	Modulator oversampling frequency				2.1	MHz
IBW	Input bandwidth				$F_{\text{Mod}}/40$ 96	kHz
N_{ch}	Number of input channels				4	n
PBR	Passband ripple				0.1	dB
SINAD	S/N and distortion		56	63		dB
THD	Total harmonic distortion		60	74		dB

Table 11. ADC electrical characteristics (continued)

Symbol	Parameter	Test conditions	Value			Unit
			Min	Typ	Max	
Z _{IN}	Input impedance	F _{Mod} = 2 MHz	1			MΩ
C _{IN}	Input capacitance				5	pF
I _{ADC}	Power consumption	T _A =27 °C		2.5	3.0	mA
I _{STBY}	Standby power consumption	T _A =27 °C			1	μA

4.7 PLL electrical characteristics

V₃₃ = 3.3 ± 10 %, V_{33IOPLL} = 3.3 ± 10 %, T_A = -40 / 85 °C unless otherwise specified.

Table 12. PLL electrical characteristics

Symbol	Parameter	Test conditions	Value			Unit
			Min	Typ	Max	
T _{PLL1}	PLL reference clock	FREF_RANGE=0	1.5		3.0	MHz
T _{PLL2}	PLL reference clock	FREF_RANGE=1 MX[1:0]='00' or '01'	3.0		8.25	MHz
T _{PLL3}	PLL reference clock	FREF_RANGE=1 MX[1:0]='10' or '11'	3.0		6	MHz
T _{LOCK}	PLL lock time	FREF_RANGE=0 Stable Input Clock Stable V _{33IOPLL} , V ₁₈			300	μs
T _{LOCK}	PLL lock time	FREF_RANGE=1 Stable Input Clock Stable V _{33IOPLL} , V ₁₈			600	μs
ΔT _{JITTER}	PLL jitter (peak to peak)	T _{PLL} = 4 MHz, MX[1:0]='11' Global Output division=32 (Output Clock=2 MHz)		0.7	2	ns

4.8 LVD electrical characteristics

V₃₃ = 3.3 ± 10 %, T_A = -40 / 85 °C unless otherwise specified.

Table 13. LVD electrical characteristics

Symbol	Parameter	Test conditions	Value			Unit
			Min	Typ	Max	
T _{LVD}	LVD Threshold	Main and LP LVD's		1.3		V
ΔV	VLPREG - T _{LVD}	Main regulator off	50			mV

4.9 GPS performances

$V_{33} = 3.3 \pm 10\%$, $T_A = 27\text{ °C}$, unless otherwise specified

Table 14. GPS performances

Symbol	Parameter	Test conditions	Value			Unit
			Min	Typ	Max	
TTFF	Reacquisition	50%, -130dBm, Fu 2ppm, Tu \pm 2, Pu 30km		<1		s
	HOt start			<2.5		s
	Warm start			<34		s
	Cold start			<39		s
Accuracy	Autonomous	CEP 50%, 24hr static at -130dBm		2		m
Sensitivity	Acquisition (Warm start)	With external LNA		-146		dBm
	Tracking			-159		dBm

5 Package information

In order to meet environmental requirements, ST offers these devices in different grades of ECOPACK® packages, depending on their level of environmental compliance. ECOPACK® specifications, grade definitions and product status are available at: www.st.com.

ECOPACK® is an ST trademark.

Figure 6. LQFP64 mechanical data and package dimensions

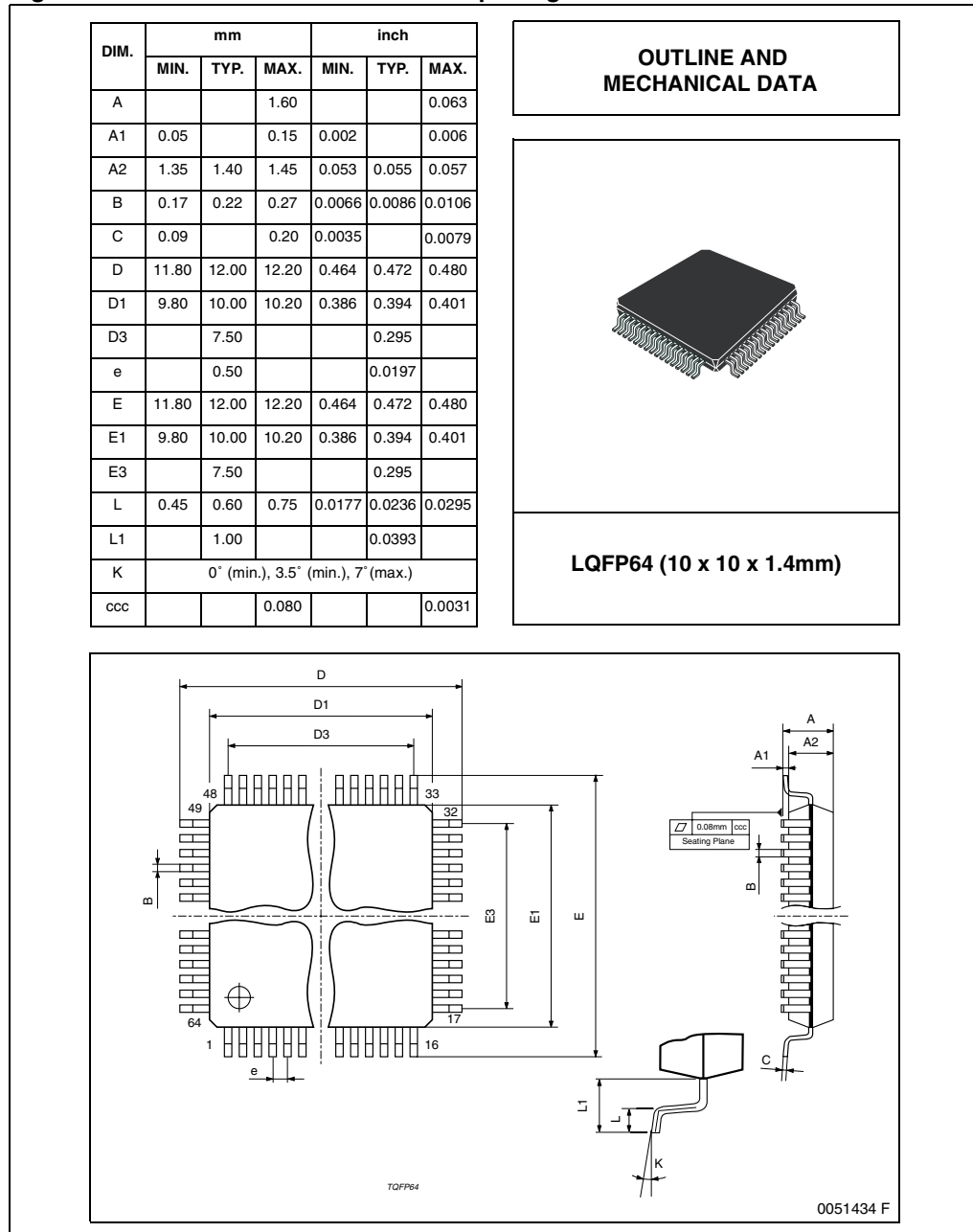
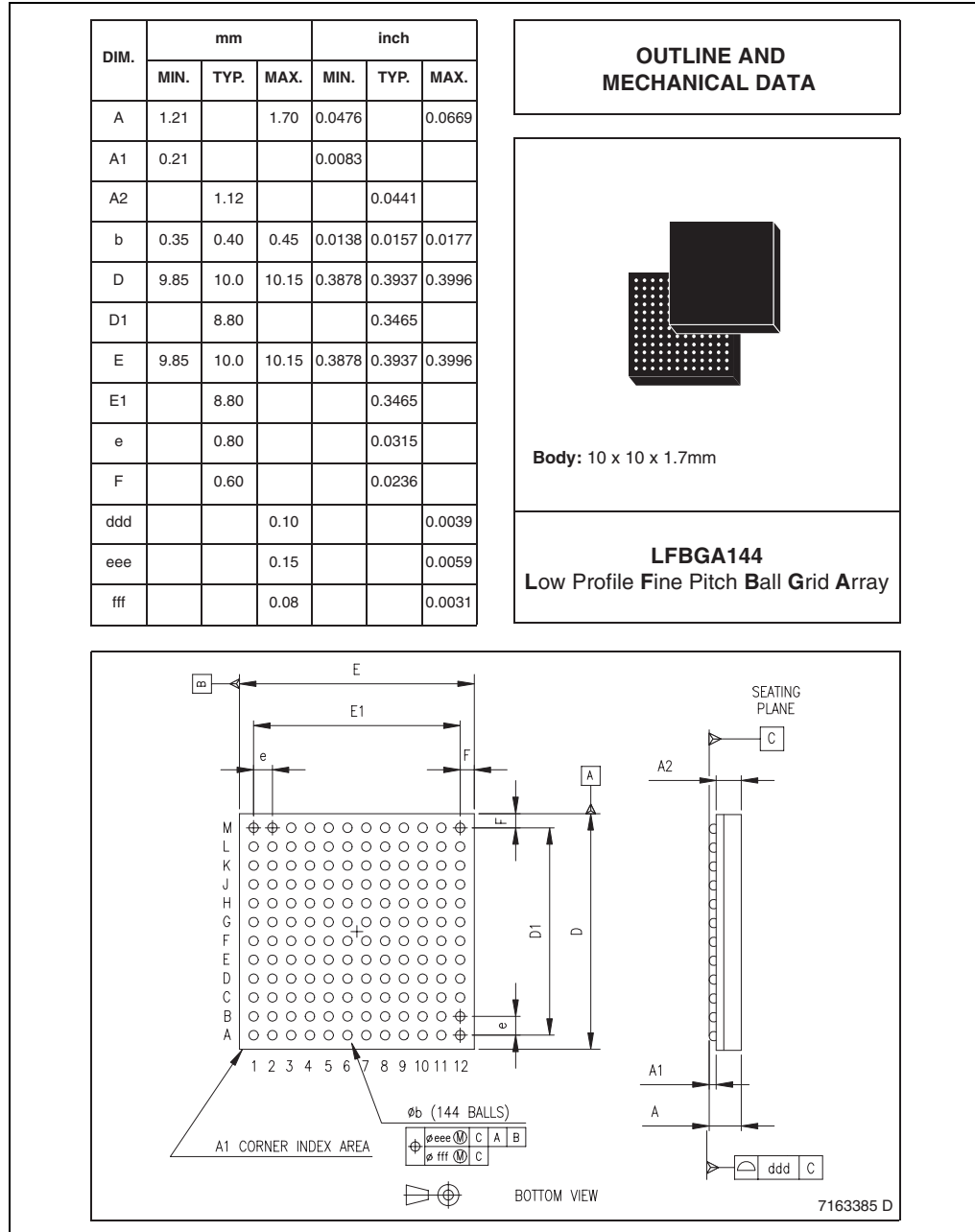

Figure 7. LFBG144 mechanical data and package dimensions



6 Revision history

Table 15. Document revision history

Date	Revision	Changes
23-Apr-2007	1	Initial release.
25-Jun-2007	2	Added features summary, pin description, electrical characteristics and packages information.
19-Mar-2009	3	Updated Table 1: Device summary on page 1 . Updated ECOPACK description in Section 5: Package information on page 17 .

Please Read Carefully:

Information in this document is provided solely in connection with ST products. STMicroelectronics NV and its subsidiaries ("ST") reserve the right to make changes, corrections, modifications or improvements, to this document, and the products and services described herein at any time, without notice.

All ST products are sold pursuant to ST's terms and conditions of sale.

Purchasers are solely responsible for the choice, selection and use of the ST products and services described herein, and ST assumes no liability whatsoever relating to the choice, selection or use of the ST products and services described herein.

No license, express or implied, by estoppel or otherwise, to any intellectual property rights is granted under this document. If any part of this document refers to any third party products or services it shall not be deemed a license grant by ST for the use of such third party products or services, or any intellectual property contained therein or considered as a warranty covering the use in any manner whatsoever of such third party products or services or any intellectual property contained therein.

UNLESS OTHERWISE SET FORTH IN ST'S TERMS AND CONDITIONS OF SALE ST DISCLAIMS ANY EXPRESS OR IMPLIED WARRANTY WITH RESPECT TO THE USE AND/OR SALE OF ST PRODUCTS INCLUDING WITHOUT LIMITATION IMPLIED WARRANTIES OF MERCHANTABILITY, FITNESS FOR A PARTICULAR PURPOSE (AND THEIR EQUIVALENTS UNDER THE LAWS OF ANY JURISDICTION), OR INFRINGEMENT OF ANY PATENT, COPYRIGHT OR OTHER INTELLECTUAL PROPERTY RIGHT.

UNLESS EXPRESSLY APPROVED IN WRITING BY AN AUTHORIZED ST REPRESENTATIVE, ST PRODUCTS ARE NOT RECOMMENDED, AUTHORIZED OR WARRANTED FOR USE IN MILITARY, AIR CRAFT, SPACE, LIFE SAVING, OR LIFE SUSTAINING APPLICATIONS, NOR IN PRODUCTS OR SYSTEMS WHERE FAILURE OR MALFUNCTION MAY RESULT IN PERSONAL INJURY, DEATH, OR SEVERE PROPERTY OR ENVIRONMENTAL DAMAGE. ST PRODUCTS WHICH ARE NOT SPECIFIED AS "AUTOMOTIVE GRADE" MAY ONLY BE USED IN AUTOMOTIVE APPLICATIONS AT USER'S OWN RISK.

Resale of ST products with provisions different from the statements and/or technical features set forth in this document shall immediately void any warranty granted by ST for the ST product or service described herein and shall not create or extend in any manner whatsoever, any liability of ST.

ST and the ST logo are trademarks or registered trademarks of ST in various countries.

Information in this document supersedes and replaces all information previously supplied.

The ST logo is a registered trademark of STMicroelectronics. All other names are the property of their respective owners.

© 2009 STMicroelectronics - All rights reserved

STMicroelectronics group of companies

Australia - Belgium - Brazil - Canada - China - Czech Republic - Finland - France - Germany - Hong Kong - India - Israel - Italy - Japan - Malaysia - Malta - Morocco - Singapore - Spain - Sweden - Switzerland - United Kingdom - United States of America

www.st.com