



# Low-Power, Dual, 12-Bit Voltage-Output DACs with Serial Interface

MAX5154/MAX5155

## General Description

## Features

The MAX5154/MAX5155 low-power, serial, voltage-output, dual 12-bit digital-to-analog converters (DACs) consume only 500µA from a single +5V (MAX5154) or +3V (MAX5155) supply. These devices feature Rail-to-Rail® output swing and are available in a space-saving 16-pin QSOP package. To maximize the dynamic range, the DAC output amplifiers are configured with an internal gain of +2V/V.

- ◆ **12-Bit Dual DAC with Internal Gain of +2V/V**
- ◆ **Rail-to-Rail Output Swing**
- ◆ **12µs Settling Time**
- ◆ **Single-Supply Operation: +5V (MAX5154)  
+3V (MAX5155)**
- ◆ **Low Quiescent Current: 500µA (normal operation)  
2µA (shutdown mode)**
- ◆ **SPI/QSPI and Microwire Compatible**
- ◆ **Available in Space-Saving 16-Pin QSOP Package**
- ◆ **Power-On Reset Clears Registers and DACs to Zero**
- ◆ **Adjustable Output Offset**

The 3-wire serial interface is SPI™/QSPI™ and Microwire™ compatible. Each DAC has a double-buffered input organized as an input register followed by a DAC register, which allows the input and DAC registers to be updated independently or simultaneously with a 16-bit serial word. Additional features include programmable shutdown (2µA), hardware-shutdown lockout (PDL), a separate reference voltage input for each DAC that accepts AC and DC signals, and an active-low clear input (CL) that resets all registers and DACs to zero. These devices provide a programmable logic pin for added functionality, and a serial-data output pin for daisy chaining.

## Ordering Information

PART	TEMP. RANGE	PIN-PACKAGE	INL (LSB)
MAX5154ACPE	0°C to +70°C	16 Plastic DIP	±1/2
MAX5154BCPE	0°C to +70°C	16 Plastic DIP	±1
MAX5154ACEE	0°C to +70°C	16 QSOP	±1/2
MAX5154BCEE	0°C to +70°C	16 QSOP	±1

## Applications

- |                                    |                                   |
|------------------------------------|-----------------------------------|
| Industrial Process Control         | Remote Industrial Controls        |
| Digital Offset and Gain Adjustment | Microprocessor-Controlled Systems |
| Motion Control                     | Automatic Test Equipment (ATE)    |

Ordering Information continued at end of data sheet.

Pin Configuration appears at end of data sheet.

## Functional Diagram

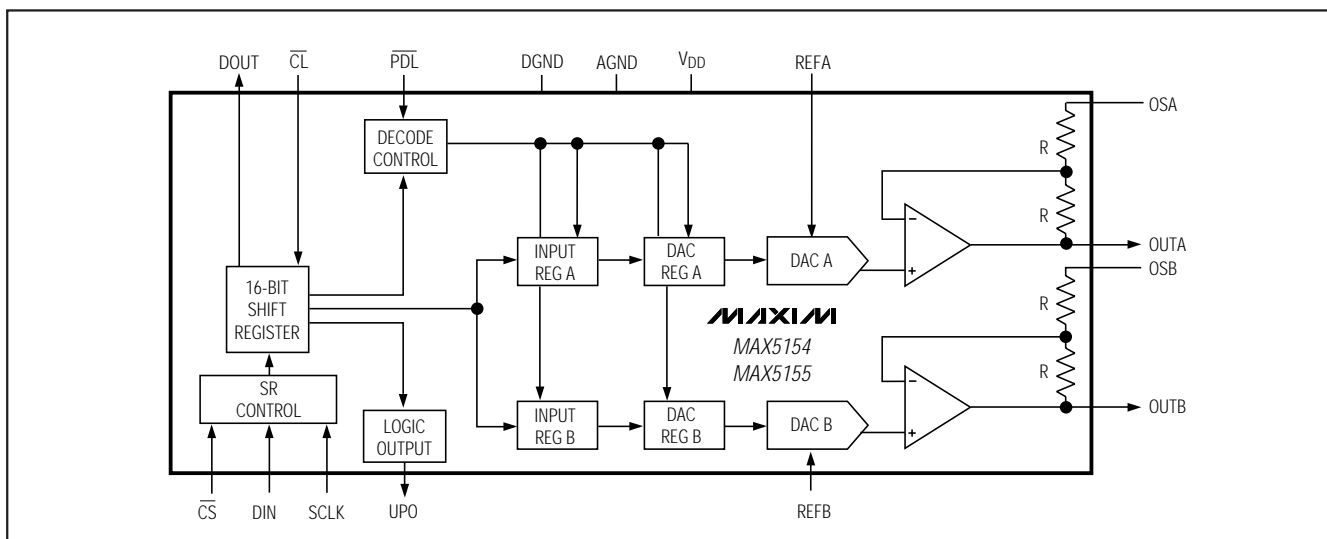

Rail-to-Rail is a registered trademark of Nippon Motorola Ltd.

SPI and QSPI are trademarks of Motorola, Inc.

Microwire is a trademark of National Semiconductor Corp.



Maxim Integrated Products 1

**For free samples & the latest literature: <http://www.maxim-ic.com>, or phone 1-800-998-8800**  
**For small orders, phone 408-737-7600 ext. 3468.**

# Low-Power, Dual, 12-Bit Voltage-Output DACs with Serial Interface

## ABSOLUTE MAXIMUM RATINGS

V <sub>DD</sub> to AGND.....	-0.3V to +6V	Continuous Power Dissipation (T <sub>A</sub> = +70°C)	
V <sub>DD</sub> to DGND.....	-0.3V to +6V	Plastic DIP (derate 10.5mW/°C above +70°C).....	842mW
AGND to DGND.....	±0.3V	QSOP (derate 8.30mW/°C above +70°C).....	667mW
OSA, OSB to AGND.....	(AGND - 4V) to (V <sub>DD</sub> + 0.3V)	CERDIP (derate 10.00mW/°C above +70°C).....	800mW
REF <sub>-</sub> , OUT <sub>-</sub> to AGND.....	-0.3V to (V <sub>DD</sub> + 0.3V)	Operating Temperature Ranges	
Digital Inputs (SCLK, DIN, CS, CL, PDL) to DGND.....	(-0.3V to +6V)	MAX515 <sub>-</sub> _C_E.....	0°C to +70°C
Digital Outputs (DO <sub>UT</sub> , UPO) to DGND.....	-0.3V to (V <sub>DD</sub> + 0.3V)	MAX515 <sub>-</sub> _E_E.....	-40°C to +85°C
Maximum Current into Any Pin.....	±20mA	MAX515 <sub>-</sub> _MJE.....	-55°C to +125°C
		Storage Temperature Range.....	-65°C to +150°C
		Lead Temperature (soldering, 10sec).....	+300°C

Stresses beyond those listed under "Absolute Maximum Ratings" may cause permanent damage to the device. These are stress ratings only, and functional operation of the device at these or any other conditions beyond those indicated in the operational sections of the specifications is not implied. Exposure to absolute maximum rating conditions for extended periods may affect device reliability.

## ELECTRICAL CHARACTERISTICS—MAX5154

(V<sub>DD</sub> = +5V ±10%, V<sub>REFA</sub> = V<sub>REFB</sub> = 2.048V, R<sub>L</sub> = 10kΩ, C<sub>L</sub> = 100pF, T<sub>A</sub> = T<sub>MIN</sub> to T<sub>MAX</sub>, unless otherwise noted. Typical values are at T<sub>A</sub> = +25°C (OS<sub>-</sub> tied to AGND for a gain of +2V/V).)

PARAMETER	SYMBOL	CONDITIONS	MIN	TYP	MAX	UNITS
<b>STATIC PERFORMANCE</b>						
Resolution			12			Bits
Integral Nonlinearity	INL	(Note 1)	MAX5154A		±1/2	LSB
			MAX5154B		±1	
Differential Nonlinearity	DNL	Guaranteed monotonic			±1	LSB
Offset Error	V <sub>OS</sub>	Code = 6			±6	mV
Offset Tempco	TCV <sub>OS</sub>	Normalized to 2.048V		4		ppm/°C
Gain Error				-0.2	±3	LSB
Gain-Error Tempco		Normalized to 2.048V		4		ppm/°C
V <sub>DD</sub> Power-Supply Rejection Ratio	PSRR	4.5V ≤ V <sub>DD</sub> ≤ 5.5V		20	260	μV/V
<b>REFERENCE INPUT</b>						
Reference Input Range	REF		0		V <sub>DD</sub> - 1.4	V
Reference Input Resistance	R <sub>REF</sub>	Minimum with code 1554 hex	14	20		kΩ
<b>MULTIPLYING-MODE PERFORMANCE</b>						
Reference 3dB Bandwidth		Input code = 1FFE hex, V <sub>REF-</sub> = 0.67V <sub>p-p</sub> at 2.5V <sub>DC</sub>		300		kHz
Reference Feedthrough		Input code = 0000 hex, V <sub>REF-</sub> = (V <sub>DD</sub> - 1.4V <sub>p-p</sub> ) at 1kHz		-82		dB
Signal-to-Noise plus Distortion Ratio	SINAD	Input code = 1FFE hex, V <sub>REF-</sub> = 1V <sub>p-p</sub> at 1.25V <sub>DC</sub> , f = 25kHz		75		dB
<b>DIGITAL INPUTS</b>						
Input High Voltage	V <sub>IH</sub>	CL, PDL, CS, DIN, SCLK	3			V
Input Low Voltage	V <sub>IL</sub>	CL, PDL, CS, DIN, SCLK			0.8	V
Input Hysteresis	V <sub>HYS</sub>			200		mV
Input Leakage Current	I <sub>IN</sub>	V <sub>IN</sub> = 0V to V <sub>DD</sub>		0.001	±1	μA
Input Capacitance	C <sub>IN</sub>			8		pF

# Low-Power, Dual, 12-Bit Voltage-Output DACs with Serial Interface

MAX5154/MAX5155

## ELECTRICAL CHARACTERISTICS—MAX5154 (continued)

( $V_{DD} = +5V \pm 10\%$ ,  $V_{REFA} = V_{REFB} = 2.048V$ ,  $R_L = 10k\Omega$ ,  $C_L = 100pF$ ,  $T_A = T_{MIN}$  to  $T_{MAX}$ , unless otherwise noted. Typical values are at  $T_A = +25^\circ C$  ( $OS_{-}$  tied to AGND for a gain of  $+2V/V$ .)

PARAMETER	SYMBOL	CONDITIONS	MIN	TYP	MAX	UNITS
<b>DIGITAL OUTPUTS (DOUT, UPO)</b>						
Output High Voltage	$V_{OH}$	$I_{SOURCE} = 2mA$	$V_{DD} - 0.5$			V
Output Low Voltage	$V_{OL}$	$I_{SINK} = 2mA$		0.13	0.40	V
<b>DYNAMIC PERFORMANCE</b>						
Voltage Output Slew Rate	SR			0.75		V/ $\mu s$
Output Settling Time		To 1/2LSB of full-scale, $V_{STEP} = 4V$		15		$\mu s$
Output Voltage Swing		Rail-to-rail (Note 2)		0 to $V_{DD}$		V
OSA or OSB Input Resistance	$R_{OS_{-}}$		24	34		$k\Omega$
Time Required to Exit Shutdown				25		$\mu s$
Digital Feedthrough		$\overline{CS} = V_{DD}$ , $f_{DIN} = 100kHz$ , $V_{SCLK} = 5Vp-p$		5		nV-s
Digital Crosstalk				5		nV-s
<b>POWER SUPPLIES</b>						
Positive Supply Voltage	$V_{DD}$		4.5		5.5	V
Power-Supply Current	$I_{DD}$	(Note 3)		0.5	0.65	mA
Power-Supply Current in Shutdown	$I_{DD(SHDN)}$	(Note 3)		2	10	$\mu A$
Reference Current in Shutdown				0	$\pm 1$	$\mu A$
<b>TIMING CHARACTERISTICS</b>						
SCLK Clock Period	$t_{CP}$	(Note 4)	100			ns
SCLK Pulse Width High	$t_{CH}$		40			ns
SCLK Pulse Width Low	$t_{CL}$		40			ns
$\overline{CS}$ Fall to SCLK Rise Setup Time	$t_{CSS}$		40			ns
SCLK Rise to $\overline{CS}$ Rise Hold Time	$t_{CSH}$		0			ns
SDI Setup Time	$t_{DS}$		40			ns
SDI Hold Time	$t_{DH}$		0			ns
SCLK Rise to DOUT Valid Propagation Delay	$t_{DO1}$	$C_{LOAD} = 200pF$			80	ns
SCLK Fall to DOUT Valid Propagation Delay	$t_{DO2}$	$C_{LOAD} = 200pF$			80	ns
SCLK Rise to $\overline{CS}$ Fall Delay	$t_{CS0}$		10			ns
$\overline{CS}$ Rise to SCLK Rise Hold	$t_{CS1}$		40			ns
$\overline{CS}$ Pulse Width High	$t_{CSW}$		100			ns

**Note 1:** Accuracy is specified from code 6 to code 4095.

**Note 2:** Accuracy is better than 1LSB for  $V_{OUT_{-}}$  greater than 6mV and less than  $V_{DD} - 50mV$ . Guaranteed by PSRR test at the end points.

**Note 3:** Digital inputs are set to either  $V_{DD}$  or DGND, code = 0000 hex,  $R_L = \infty$ .

**Note 4:** SCLK minimum clock period includes the rise and fall times.

# Low-Power, Dual, 12-Bit Voltage-Output DACs with Serial Interface

## ELECTRICAL CHARACTERISTICS—MAX5155

( $V_{DD} = +2.7V$  to  $+3.6V$ ,  $V_{REFA} = V_{REFB} = 1.25V$ ,  $R_L = 10k\Omega$ ,  $C_L = 100pF$ ,  $T_A = T_{MIN}$  to  $T_{MAX}$ , unless otherwise noted. Typical values are at  $T_A = +25^\circ C$  (OS\_ pins tied to AGND for a gain of  $+2V/V$ .)

PARAMETER	SYMBOL	CONDITIONS	MIN	TYP	MAX	UNITS
<b>STATIC PERFORMANCE</b>						
Resolution			12			Bits
Integral Nonlinearity	INL	(Note 5)	MAX5155A		$\pm 1$	LSB
			MAX5155B		$\pm 2$	
Differential Nonlinearity	DNL	Guaranteed monotonic			$\pm 1$	LSB
Offset Error	$V_{OS}$	Code = 10			$\pm 6$	mV
Offset Tempco	$TCV_{OS}$	Normalized to 1.25V		6.5		ppm/ $^\circ C$
Gain Error				-0.2	$\pm 4$	LSB
Gain-Error Tempco		Normalized to 1.25V		6.5		ppm/ $^\circ C$
$V_{DD}$ Power-Supply Rejection Ratio	PSRR	$2.7V \leq V_{DD} \leq 3.6V$		40	320	$\mu V/V$
<b>REFERENCE INPUT (VREF)</b>						
Reference Input Range	REF		0		$V_{DD} - 1.4$	V
Reference Input Resistance	$R_{REF}$	Minimum with code 1554 hex	14	20		$k\Omega$
<b>MULTIPLYING-MODE PERFORMANCE</b>						
Reference 3dB Bandwidth		Input code = 1FFE hex, $V_{REF\_} = 0.67V_{p-p}$ at $0.75V_{DC}$		300		kHz
Reference Feedthrough		Input code = 0000 hex, $V_{REF\_} = (V_{DD} - 1.4)V_{p-p}$ at 1kHz		-82		dB
Signal-to-Noise plus Distortion Ratio	SINAD	Input code = 1FFE hex, $V_{REF\_} = 1V_{p-p}$ at $1V_{DC}$ , $f = 15kHz$		73		dB
<b>DIGITAL INPUTS</b>						
Input High Voltage	$V_{IH}$	$\overline{CL}$ , $\overline{PDL}$ , $\overline{CS}$ , DIN, SCLK	2.2			V
Input Low Voltage	$V_{IL}$	$\overline{CL}$ , $\overline{PDL}$ , $\overline{CS}$ , DIN, SCLK			0.8	V
Input Hysteresis	$V_{HYS}$			200		mV
Input Leakage Current	$I_{IN}$	$V_{IN} = 0V$ to $V_{DD}$		0	$\pm 1$	$\mu A$
Input Capacitance	$C_{IN}$			8		pF
<b>DIGITAL OUTPUTS (DOUT, UPO)</b>						
Output High Voltage	$V_{OH}$	$I_{SOURCE} = 2mA$	$V_{DD} - 0.5$			V
Output Low Voltage	$V_{OL}$	$I_{SINK} = 2mA$		0.13	0.4	V
<b>DYNAMIC PERFORMANCE</b>						
Voltage Output Slew Rate	SR			0.75		$V/\mu s$
Output Settling Time		To 1/2LSB of full-scale, $V_{STEP} = 2.5V$		15		$\mu s$
Output Voltage Swing		Rail-to-rail (Note 6)		0 to $V_{DD}$		V
OSA or OSB Input Resistance	$R_{OS\_}$		24	34		$k\Omega$
Time Required for Valid Operation after Shutdown				25		$\mu s$
Digital Feedthrough		$\overline{CS} = V_{DD}$ , $f_{DIN} = 100kHz$ , $V_{SCLK} = 3V_{p-p}$		5		nV-s
Digital Crosstalk				5		nV-s

# Low-Power, Dual, 12-Bit Voltage-Output DACs with Serial Interface

MAX5154/MAX5155

## ELECTRICAL CHARACTERISTICS—MAX5155 (continued)

( $V_{DD} = +2.7V$  to  $+3.6V$ ,  $V_{REFA} = V_{REFB} = 1.25V$ ,  $R_L = 10k\Omega$ ,  $C_L = 100pF$ ,  $T_A = T_{MIN}$  to  $T_{MAX}$ , unless otherwise noted. Typical values are at  $T_A = +25^\circ C$  (OS\_ pins tied to AGND for a gain of  $+2V/V$ .)

PARAMETER	SYMBOL	CONDITIONS	MIN	TYP	MAX	UNITS
<b>POWER SUPPLIES</b>						
Positive Supply Voltage	$V_{DD}$		2.7		3.6	V
Power-Supply Current	$I_{DD}$	(Note 7)		0.45	0.6	mA
Power-Supply Current in Shutdown	$I_{DD} (SHDN)$	(Note 7)		1	8	$\mu A$
Reference Current in Shutdown				0	$\pm 1$	$\mu A$
<b>TIMING CHARACTERISTICS</b>						
SCLK Clock Period	$t_{CP}$	(Note 4)	100			ns
SCLK Pulse Width High	$t_{CH}$		40			ns
SCLK Pulse Width Low	$t_{CL}$		40			ns
$\overline{CS}$ Fall to SCLK Rise Setup Time	$t_{CSS}$		40			ns
SCLK Rise to $\overline{CS}$ Rise Hold Time	$t_{CSH}$		0			ns
SDI Setup Time	$t_{DS}$		50			ns
SDI Hold Time	$t_{DH}$		0			ns
SCLK Rise to DOUT Valid Propagation Delay	$t_{DO1}$	$C_{LOAD} = 200pF$			120	ns
SCLK Fall to DOUT Valid Propagation Delay	$t_{DO2}$	$C_{LOAD} = 200pF$			120	ns
SCLK Rise to $\overline{CS}$ Fall Delay	$t_{CS0}$		10			ns
$\overline{CS}$ Rise to SCLK Rise Hold	$t_{CS1}$		40			ns
$\overline{CS}$ Pulse Width High	$t_{CSW}$		100			ns

**Note 5:** Accuracy is specified from code 10 to code 4095.

**Note 6:** Accuracy is better than 1LSB for  $V_{OUT}$  greater than 6mV and less than  $V_{DD} - 80mV$ . Guaranteed by PSRR test at the end points.

**Note 7:** Digital inputs are set to either  $V_{DD}$  or DGND, code = 0000 hex,  $R_L = \infty$ .

# Low-Power, Dual, 12-Bit Voltage-Output DACs with Serial Interface

## Typical Operating Characteristics

( $V_{DD} = +5V$ ,  $R_L = 10k\Omega$ ,  $C_L = 100pF$ , OS\_ pins tied to AGND,  $T_A = +25^\circ C$ , unless otherwise noted.)

### MAX5154

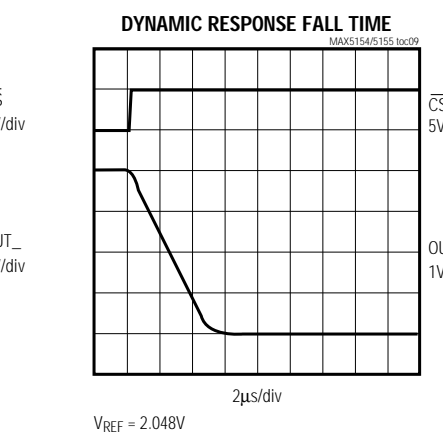
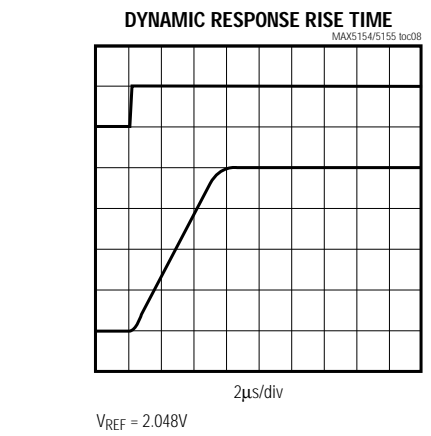
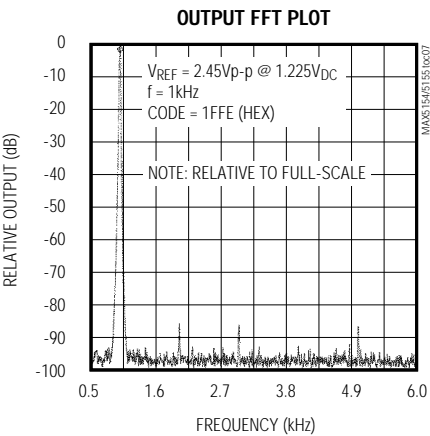
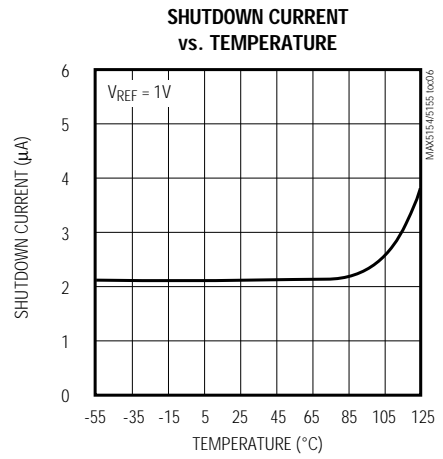
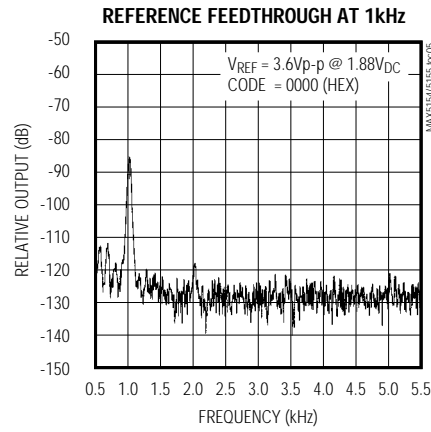
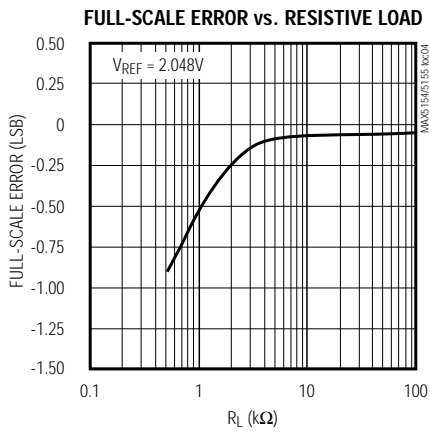
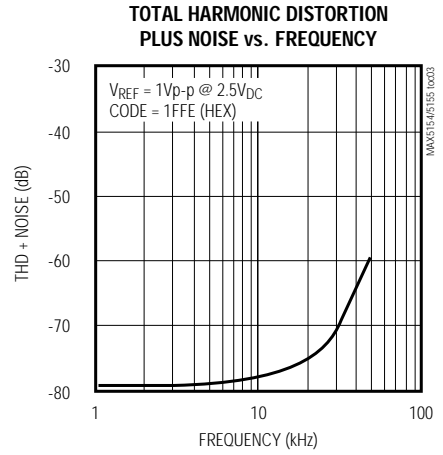
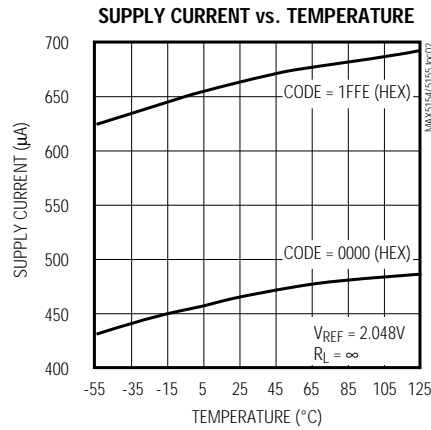
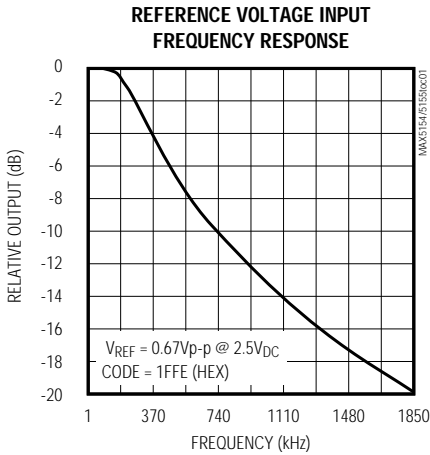

# Low-Power, Dual, 12-Bit Voltage-Output DACs with Serial Interface

## Typical Operating Characteristics (continued)

( $V_{DD} = +3V$ ,  $R_L = 10k\Omega$ ,  $C_L = 100pF$ , OS\_pins tied to AGND,  $T_A = +25^\circ C$ , unless otherwise noted.)

MAX5154/MAX5155

### MAX5155

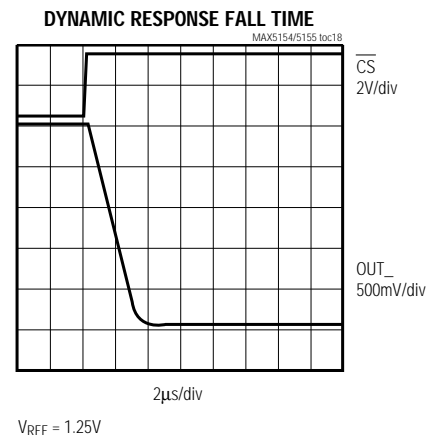
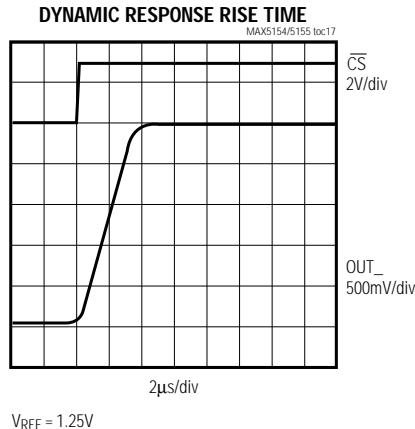
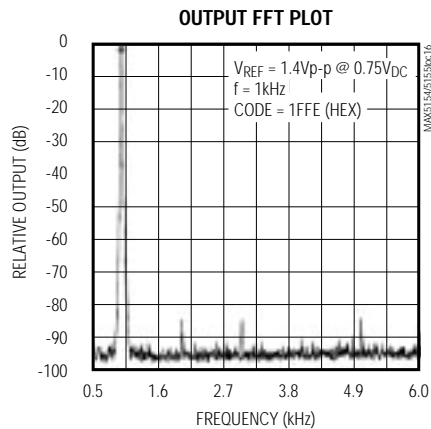
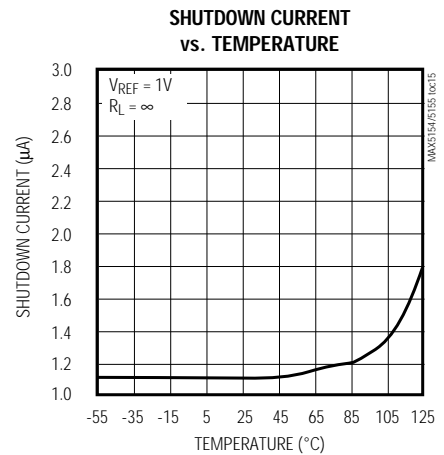
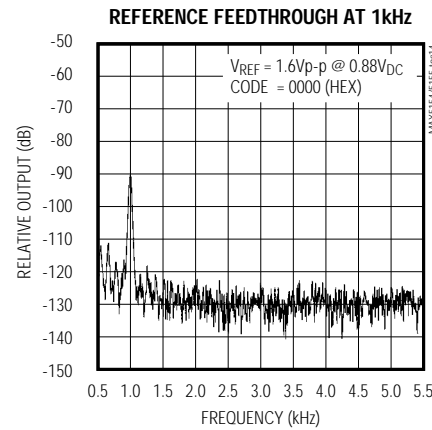
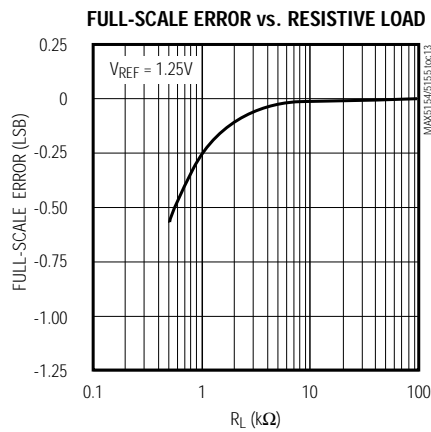
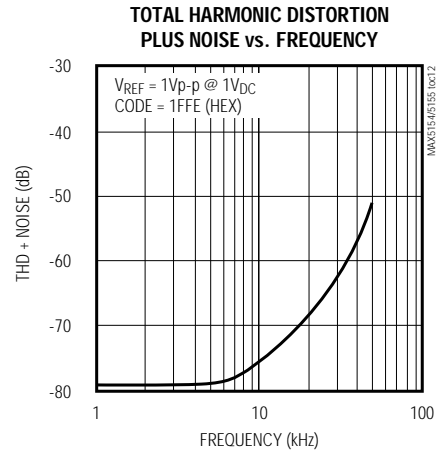
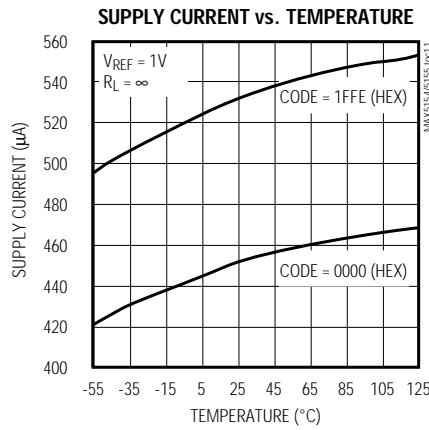
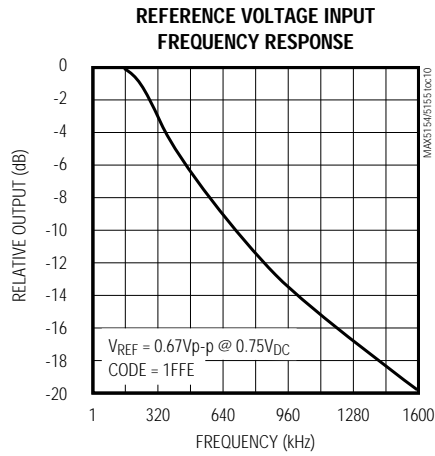

# Low-Power, Dual, 12-Bit Voltage-Output DACs with Serial Interface

## Typical Operating Characteristics (continued)

( $V_{DD} = +5V$  (MAX5154),  $V_{DD} = +3V$  (MAX5155),  $R_L = 10k\Omega$ ,  $C_L = 100pF$ ,  $OS_{-}$  pins tied to AGND, unless otherwise noted.)

### MAX5154/MAX5155

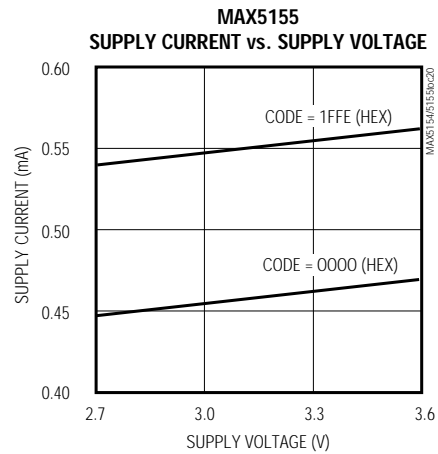
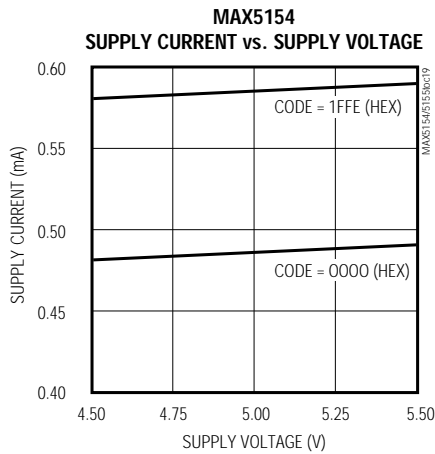

**MAX5154**  
MAJOR-CARRY TRANSITION

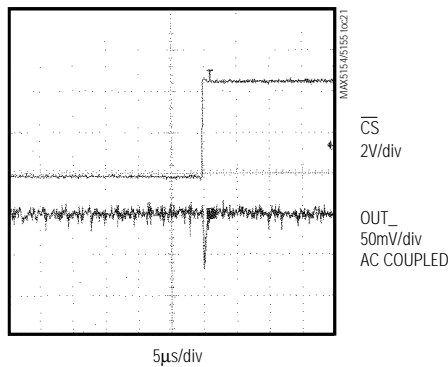

TRANSITION FROM 1000 (HEX) TO OFFE (HEX)

**MAX5154**  
ANALOG CROSSTALK

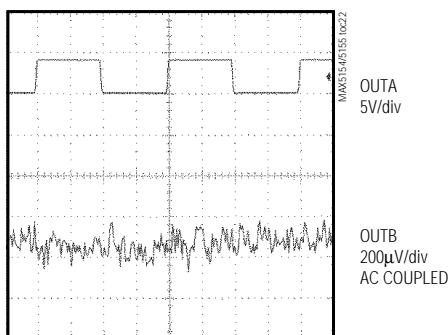

$V_{REF} = 2.048V$ , GAIN = +2V/V, CODE = 1FFE HEX

**MAX5154**  
DIGITAL FEEDTHROUGH

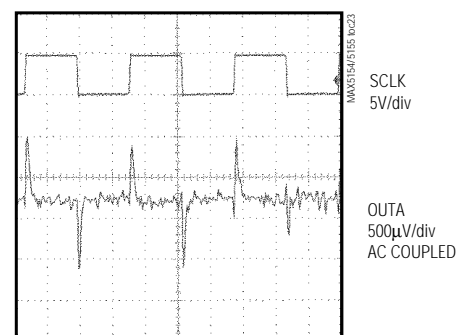



# Low-Power, Dual, 12-Bit Voltage-Output DACs with Serial Interface

MAX5154/MAX5155

## Pin Description

PIN	NAME	FUNCTION
1	AGND	Analog Ground
2	OUTA	DAC A Output Voltage
3	OSA	DAC A Offset Adjustment
4	REFA	Reference for DAC A
5	$\overline{CL}$	Active-Low Clear Input. Resets all registers to zero. DAC outputs go to 0V.
6	$\overline{CS}$	Chip-Select Input
7	DIN	Serial-Data Input
8	SCLK	Serial Clock Input
9	DGND	Digital Ground
10	DOUT	Serial-Data Output
11	UPO	User-Programmable Output
12	$\overline{PDL}$	Power-Down Lockout. The device cannot be powered down when $\overline{PDL}$ is low.
13	REFB	Reference for DAC B
14	OSB	DAC B Offset Adjustment
15	OUTB	DAC B Output Voltage
16	V <sub>DD</sub>	Positive Power Supply

## Detailed Description

The MAX5154/MAX5155 dual, 12-bit, voltage-output DACs are easily configured with a 3-wire serial interface. These devices include a 16-bit data-in/data-out shift register, and each DAC has a double-buffered input composed of an input register and a DAC register (see *Functional Diagram*). In addition, trimmed internal resistors produce an internal gain of +2V/V that maximizes output voltage swing. The amplifier's offset-adjust pin allows for a DC shift in the DAC's output.

Both DACs use an inverted R-2R ladder network that produces a weighted voltage proportional to the input voltage value. Each DAC has its own reference input to facilitate independent full-scale values. Figure 1 depicts a simplified circuit diagram of one of the two DACs.

### Reference Inputs

The reference inputs accept both AC and DC values with a voltage range extending from 0V to (V<sub>DD</sub> - 1.4V). Determine the output voltage using the following equation (OS<sub>-</sub> = AGND):

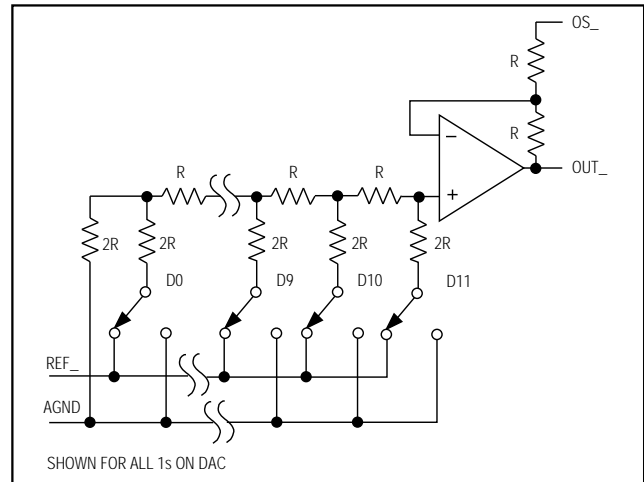

Figure 1. Simplified DAC Circuit Diagram

$$V_{OUT} = (V_{REF} \times NB / 4096) \times 2$$

where NB is the numeric value of the DAC's binary input code (0 to 4095) and V<sub>REF</sub> is the reference voltage.

The reference input impedance ranges from 14kΩ (1554 hex) to several giga ohms (with an input code of 0000 hex). The reference input capacitance is code dependent and typically ranges from 15pF with an input code of all zeros to 50pF with a full-scale input code.

### Output Amplifier

The output amplifiers on the MAX5154/MAX5155 have internal resistors that provide for a gain of +2V/V when OS<sub>-</sub> is connected to AGND. These resistors are trimmed to minimize gain error. The output amplifiers have a typical slew rate of 0.75V/μs and settle to 1/2LSB within 15μs, with a load of 10kΩ in parallel with 100pF. Loads less than 2kΩ degrade performance.

The OS<sub>-</sub> pin can be used to produce an adjustable offset voltage at the output. For instance, to achieve a 1V offset, apply -1V to the OS<sub>-</sub> pin to produce an output range from 1V to (1V + V<sub>REF</sub> × 2). Note that the DAC's output range is still limited by the maximum output voltage specification.

### Power-Down Mode

The MAX5154/MAX5155 feature a software-programmable shutdown mode that reduces the typical supply current to 2μA. The two DACs can be shutdown independently, or simultaneously using the appropriate programming command. Enter shutdown mode by writing the appropriate input-control word (Table 1). In shutdown mode, the reference inputs and amplifier outputs become high impedance, and the serial interface remains active. Data in the input registers is

# Low-Power, Dual, 12-Bit Voltage-Output DACs with Serial Interface

**Table 1. Serial-Interface Programming Commands**

16-BIT SERIAL WORD					FUNCTION
A0	C1	C0	D11.....D0 (MSB) (LSB)	S0	
0	0	1	12-bit DAC data	0	Load input register A; DAC registers are unchanged.
1	0	1	12-bit DAC data	0	Load input register B; DAC registers are unchanged.
0	1	0	12-bit DAC data	0	Load input register A; all DAC registers are updated.
1	1	0	12-bit DAC data	0	Load input register B; all DAC registers are updated.
0	1	1	12-bit DAC data	0	Load all DAC registers from the shift register (start up both DACs with new data.).
1	0	0	xxxxxxxxxxx	0	Update both DAC registers from their respective input registers (start up both DACs with data previously stored in the input registers).
1	1	1	xxxxxxxxxxx	0	Shut down both DACs (provided $\overline{\text{PDL}} = 1$ ).
0	0	0	0 0 1 x xxxxxxxx	0	Update DAC register A from input register A (start up DAC A with data previously stored in input register A).
0	0	0	1 0 1 x xxxxxxxx	0	Update DAC register B from input register B (start up DAC B with data previously stored in input register B).
0	0	0	1 1 0 x xxxxxxxx	0	Shut down DAC A (provided $\overline{\text{PDL}} = 1$ ).
0	0	0	1 1 1 x xxxxxxxx	0	Shut down DAC B (provided $\overline{\text{PDL}} = 1$ ).
0	0	0	0 1 0 x xxxxxxxx	0	UPO goes low (default).
0	0	0	0 1 1 x xxxxxxxx	0	UPO goes high.
0	0	0	1 0 0 1 xxxxxxxx	0	Mode 1, DOUT clocked out on SCLK's rising edge.
0	0	0	1 0 0 0 xxxxxxxx	0	Mode 0, DOUT clocked out on SCLK's falling edge (default).
0	0	0	0 0 0 x xxxxxxxx	0	No operation (NOP).

x = Don't care

**Note:** D11, D10, D9, and D8 become control bits when A0, C1, and C0 = 0. S0 is a sub bit, always zero.

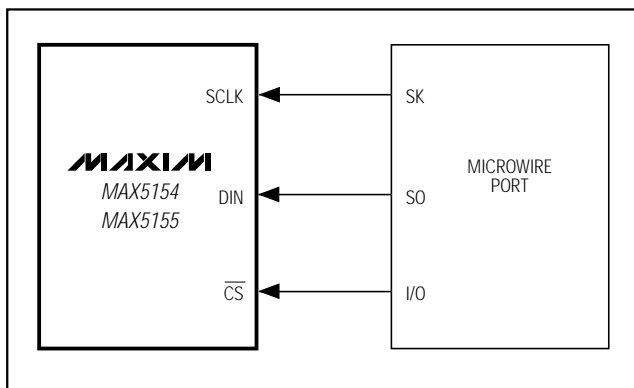

Figure 2. Connections for Microwire

saved, allowing the MAX5154/MAX5155 to recall the output state prior to entering shutdown when returning to normal mode. Exit shutdown by recalling the previous condition or by updating the DAC with new information. When returning to normal operation (exiting shutdown), wait 20µs for output stabilization.

### Serial Interface

The MAX5154/MAX5155 3-wire serial interface is compatible with both Microwire (Figure 2) and SPI/QSPI (Figure 3) serial-interface standards. The 16-bit serial input word consists of an address bit, two control bits, 12 bits of data (MSB to LSB), and one sub bit as shown in Figure 4. The address and control bits determine the MAX5154/ MAX5155's response, as outlined in Table 1.

# Low-Power, Dual, 12-Bit Voltage-Output DACs with Serial Interface

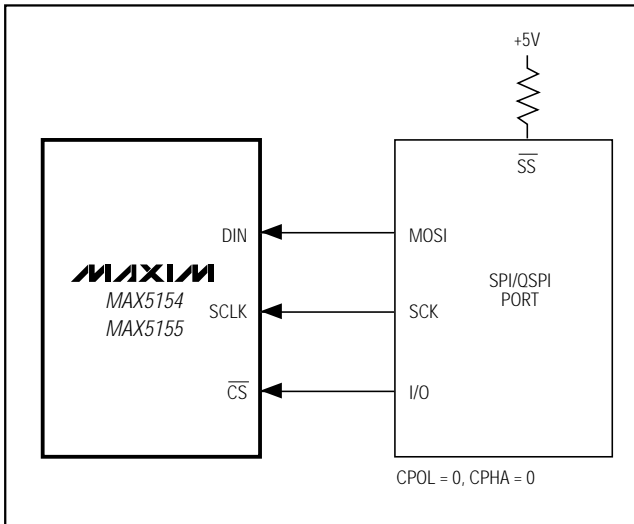

Figure 3. Connections for SPI/QSPI

The MAX5154/MAX5155's digital inputs are double buffered, which allows any of the following: loading the input register(s) without updating the DAC register(s), updating the DAC register(s) from the input register(s), or updating the input and DAC registers concurrently. The address and control bits allow the DACs to act independently.

Send the 16-bit data as one 16-bit word (QSPI) or two 8-bit packets (SPI, Microwire), with  $\overline{CS}$  low during this period. The address and control bits determine which register will be updated, and the state of the registers when exiting shutdown. The 3-bit address/control determines the following:

- registers to be updated
- clock edge on which data is to be clocked out via the serial-data output (DOUT)
- state of the user-programmable logic output
- configuration of the device after shutdown.

The general timing diagram of Figure 5 illustrates how data is acquired. Driving  $\overline{CS}$  low enables the device to receive data. Otherwise, the interface control circuitry is disabled. With  $\overline{CS}$  low, data at DIN is clocked into the register on the rising edge of SCLK. As  $\overline{CS}$  goes high, data is latched into the input and/or DAC registers depending on the address and control bits. The maximum clock frequency guaranteed for proper operation is 10MHz. Figure 6 depicts a more detailed timing diagram of the serial interface.

MSB.....LSB			
← 16 Bits of Serial Data →			
Address Bits	Control Bits	MSB...DataBits...LSB	SUB BIT
A0	C1, C0	D11.....D0	S0
← 1 Address/2 Control Bits →		← 12 Data Bits →	

Figure 4. Serial-Data Format

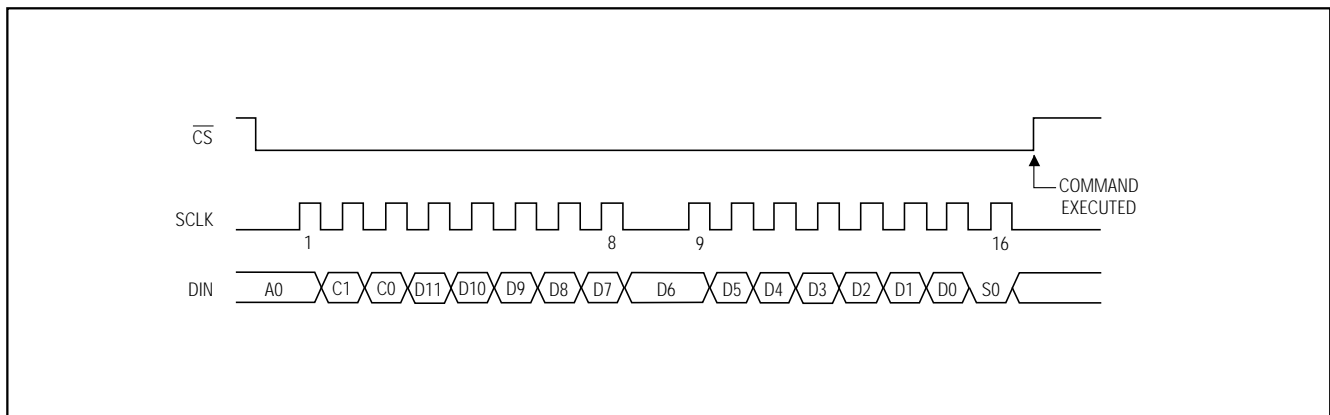

Figure 5. Serial-Interface Timing Diagram

# Low-Power, Dual, 12-Bit Voltage-Output DACs with Serial Interface

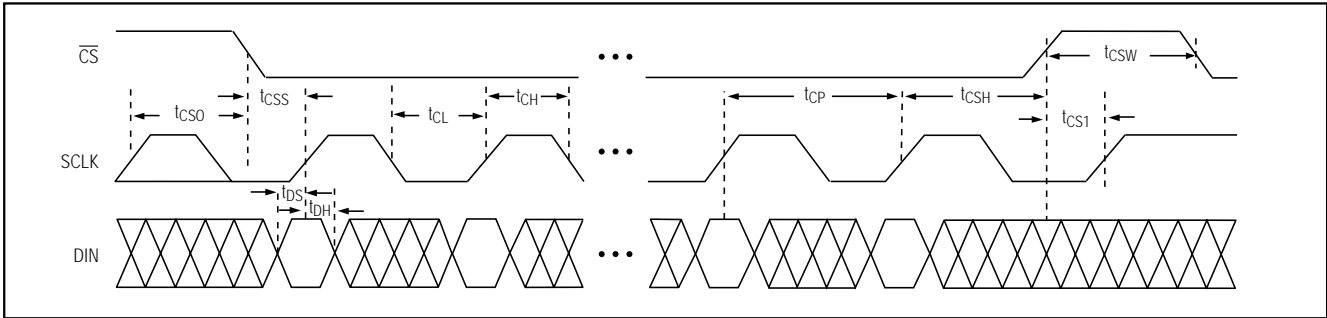

Figure 6. Detailed Serial-Interface Timing Diagram

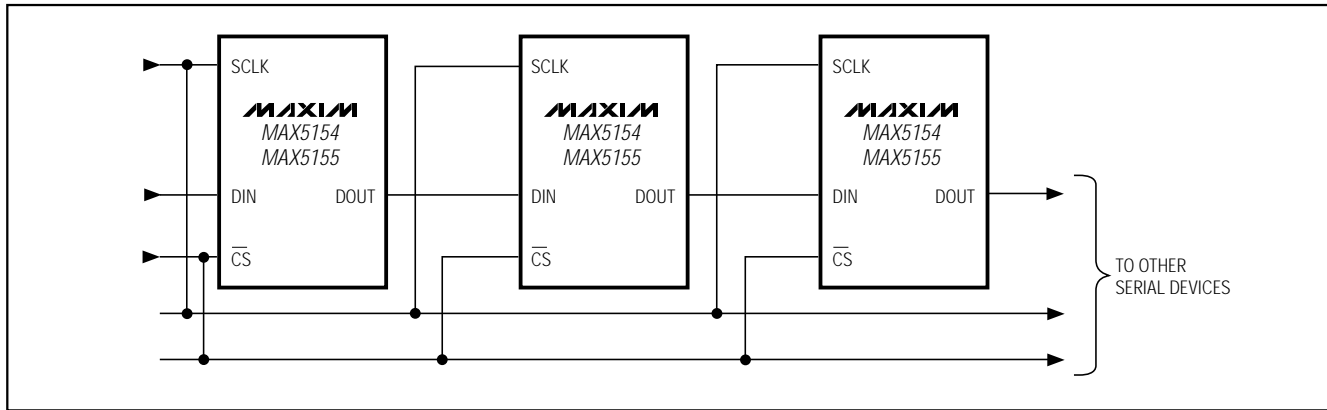

Figure 7. Daisy Chaining MAX5154/MAX5155s

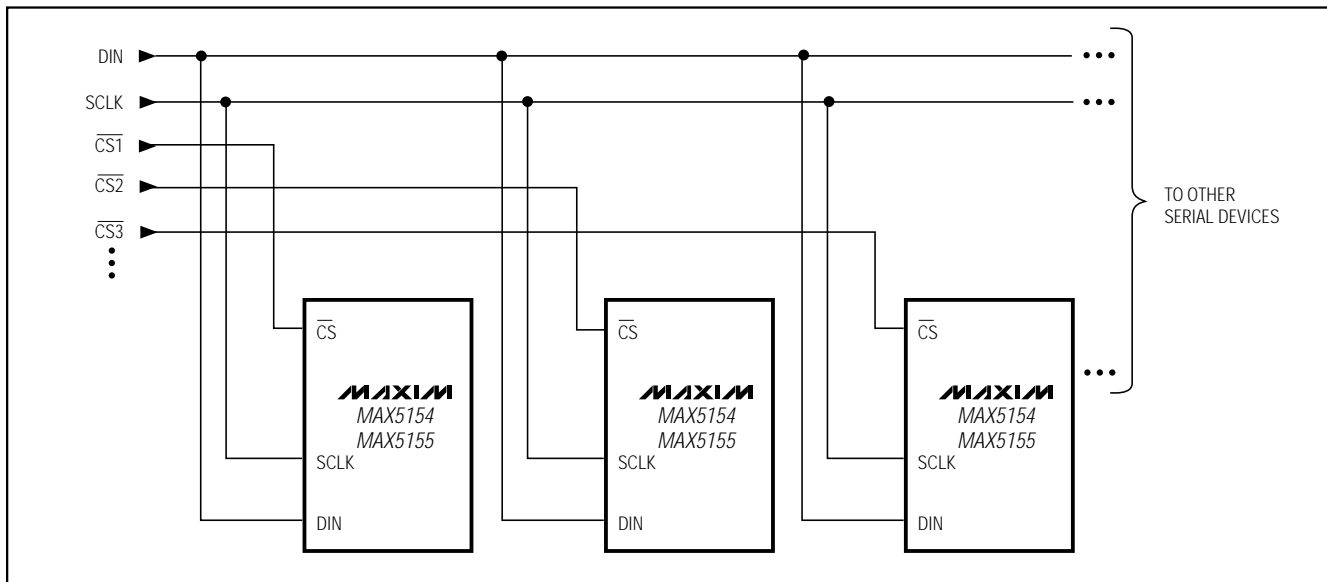

Figure 8. Multiple MAX5154/MAX5155s Sharing a Common DIN Line

# Low-Power, Dual, 12-Bit Voltage-Output DACs with Serial Interface

MAX5154/MAX5155

## Serial-Data Output

The serial-data output, DOUT, is the internal shift register's output. DOUT allows for daisy chaining of devices and data readback. The MAX5154/MAX5155 can be programmed to shift data out of DOUT on SCLK's falling edge (Mode 0) or on the rising edge (Mode 1). Mode 0 provides a lag of 16 clock cycles, which maintains compatibility with SPI/OSPI and Microwire interfaces. In Mode 1, the output data lags 15.5 clock cycles. On power-up, the device defaults to Mode 0.

## User-Programmable Logic Output (UPO)

UPO allows an external device to be controlled through the serial interface (Table 1), thereby reducing the number of microcontroller I/O pins required. On power-up, UPO is low.

## Power-Down Lockout Input (PDL)

The power-down lockout pin ( $\overline{\text{PDL}}$ ) disables software shutdown when low. When in shutdown, transitioning  $\overline{\text{PDL}}$  from high to low wakes up the part with the output set to the state prior to shutdown.  $\overline{\text{PDL}}$  can also be used to asynchronously wake up the device.

## Daisy Chaining Devices

Any number of MAX5154/MAX5155s can be daisy chained by connecting the DOUT pin of one device to the DIN pin of the following device in the chain (Figure 7).

Since the MAX5154/MAX5155's DOUT pin has an internal active pull-up, the DOUT sink/source capability determines the time required to discharge/charge a capacitive load. Refer to the digital output  $V_{OH}$  and  $V_{OL}$  specifications in the *Electrical Characteristics*.

Figure 8 shows an alternate method of connecting several MAX5154/MAX5155s. In this configuration, the data bus is common to all devices; data is not shifted through a daisy chain. More I/O lines are required in this configuration because a dedicated chip-select input ( $\overline{\text{CS}}$ ) is required for each IC.

## Applications Information

### Unipolar Output

Figure 9 shows the MAX5154/MAX5155 configured for unipolar, rail-to-rail operation with a gain of +2V/V. The MAX5154 can produce a 0V to 4.096V output with 2.048V reference (Figure 9), while the MAX5155 can produce a range of 0V to 2.5V with a 1.25V reference. Table 2 lists the unipolar output codes. An offset to the output can be achieved by connecting a voltage to  $\text{OS}_-$ , as shown in Figure 10. By applying  $V_{OS_-} = -1V$ , the output values will range between 1V and  $(1V + V_{REF} \times 2)$ .

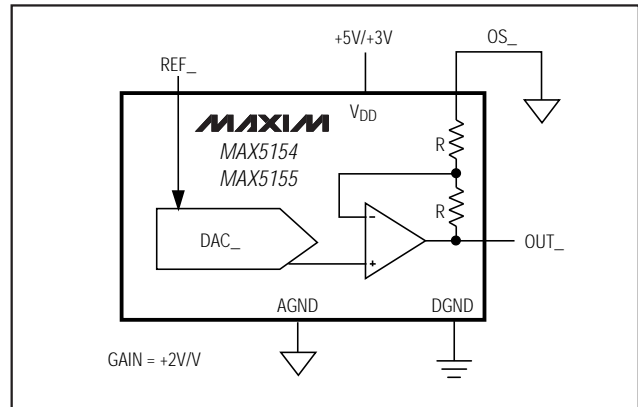

Figure 9. Unipolar Output Circuit (Rail-to-Rail)

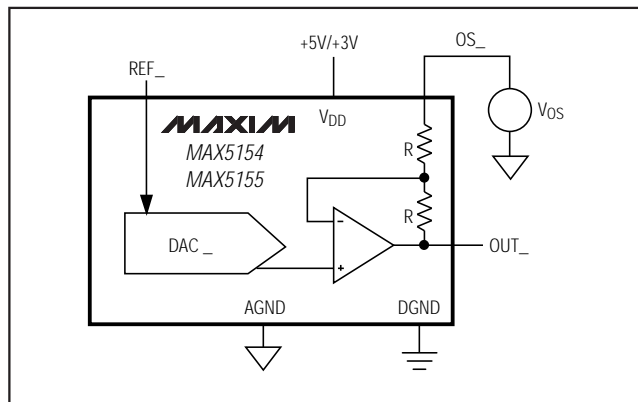

Figure 10. Setting  $\text{OS}_-$  for Output Offset

Table 2. Unipolar Code Table (Gain = +2)

DAC CONTENTS MSB	LSB	ANALOG OUTPUT
1111	1111 1111 (0)	$+V_{REF} \left( \frac{4095}{4096} \right) \times 2$
1000	0000 0001 (0)	$+V_{REF} \left( \frac{2049}{4096} \right) \times 2$
1000	0000 0000 (0)	$+V_{REF} \left( \frac{2048}{4096} \right) \times 2 = V_{REF}$
0111	1111 1111 (0)	$+V_{REF} \left( \frac{2047}{4096} \right) \times 2$
0000	0000 0001 (0)	$+V_{REF} \left( \frac{1}{4096} \right) \times 2$
0000	0000 0000 (0)	0V

Note: ( ) are for the sub bit.

# Low-Power, Dual, 12-Bit Voltage-Output DACs with Serial Interface

**Table 3. Bipolar Code Table**

DAC CONTENTS MSB	LSB	ANALOG OUTPUT
1111 1111 1 111 (0)		$+V_{REF} \left( \frac{2047}{2048} \right)$
1000 0000 0 001 (0)		$+V_{REF} \left( \frac{1}{2048} \right)$
1000 0000 0 000 (0)		0V
0111 1111 1 111 (0)		$-V_{REF} \left( \frac{1}{2048} \right)$
0000 0000 0 001 (0)		$-V_{REF} \left( \frac{2047}{2048} \right)$
0000 0000 0 000 (0)		$-V_{REF} \left( \frac{2048}{2048} \right) = -V_{REF}$

**Note:** ( ) are for the sub bit.

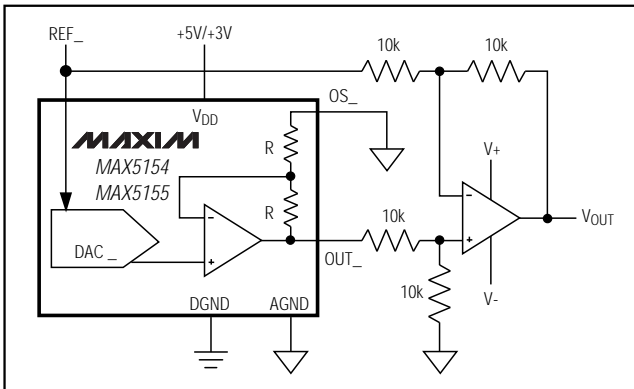

Figure 11. Bipolar Output Circuit

### Bipolar Output

The MAX5154/MAX5155 can be configured for a bipolar output, as shown in Figure 11. The output voltage is given by the equation ( $OS_- = AGND$ ):

$$V_{OUT} = V_{REF} \left[ \left( \frac{2 \times NB}{4096} \right) - 1 \right]$$

where NB represents the numeric value of the DAC's binary input code. Table 3 shows digital codes and the corresponding output voltage for Figure 11's circuit.

### Using an AC Reference

In applications where the reference has an AC signal component, the MAX5154/MAX5155 have multiplying capabilities within the reference input voltage range specifications. Figure 12 shows a technique for applying

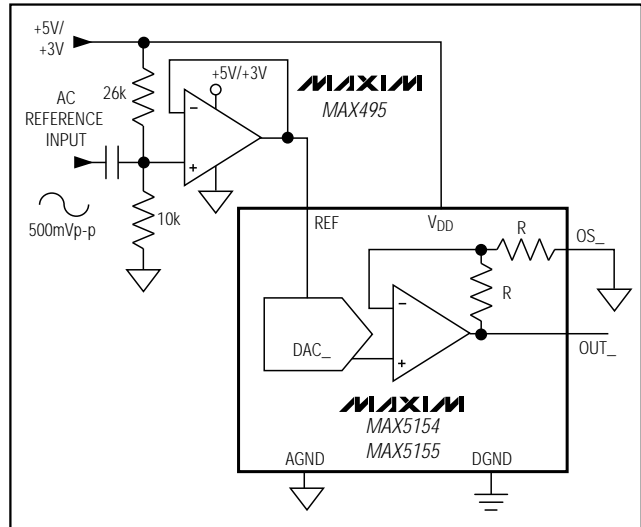

Figure 12. AC Reference Input Circuit

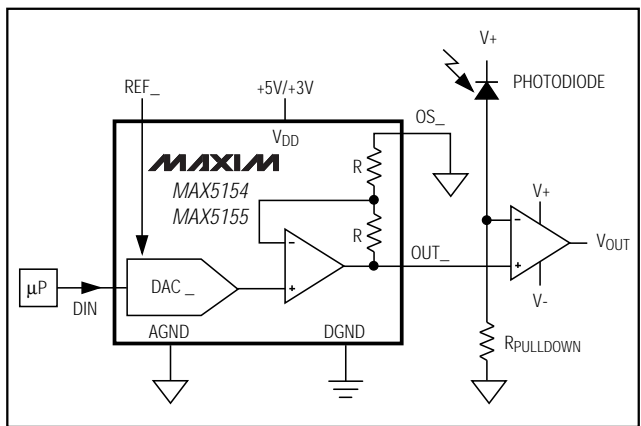

Figure 13. Digital Calibration

ing a sinusoidal input to REF\_, where the AC signal is offset before being applied to the reference input.

### Harmonic Distortion and Noise

The total harmonic distortion plus noise (THD+N) is typically less than -78dB at full scale with a 1Vp-p input swing at 5kHz. The typical -3dB frequency is 300kHz for both devices, as shown in the *Typical Operating Characteristics*.

### Digital Calibration and Threshold Selection

Figure 13 shows the MAX5154/MAX5155 in a digital calibration application. With a bright light value applied to the photodiode (on), the DAC is digitally ramped until

# Low-Power, Dual, 12-Bit Voltage-Output DACs with Serial Interface

MAX5154/MAX5155

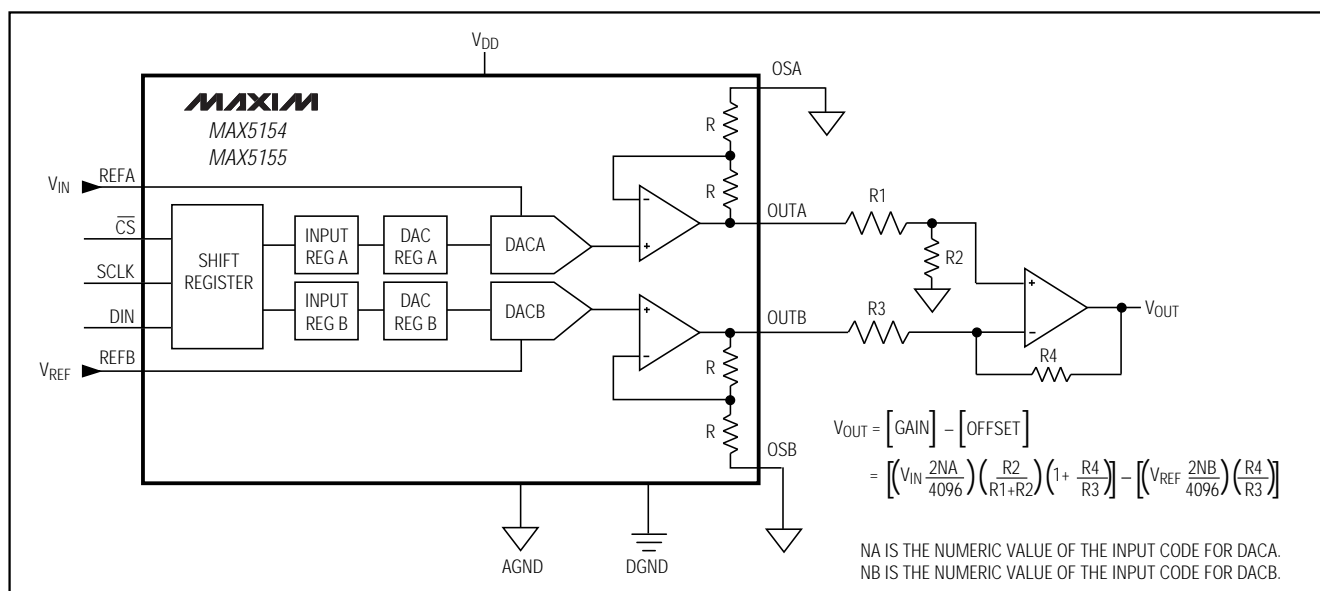

Figure 14. Digital Control of Gain and Offset

it trips the comparator. The microprocessor ( $\mu\text{P}$ ) stores this "high" calibration value. Repeat the process with a dim light (off) to obtain the dark current calibration. The  $\mu\text{P}$  then programs the DAC to set an output voltage at the midpoint of the two calibrated values. Applications include tachometers, motion sensing, automatic readers, and liquid clarity analysis.

### Digital Control of Gain and Offset

The two DACs can be used to control the offset and gain for curve-fitting nonlinear functions, such as transducer linearization or analog compression/expansion applications. The input signal is used as the reference for the gain-adjust DAC, whose output is summed with the output from the offset-adjust DAC. The relative weight of each DAC output is adjusted by R1, R2, R3, and R4 (Figure 14).

### Power-Supply Considerations

On power-up, the input and DAC registers clear (set to zero code). For rated performance,  $V_{REF}$  should be at least 1.4V below  $V_{DD}$ . Bypass the power supply with a 4.7 $\mu\text{F}$  capacitor in parallel with a 0.1 $\mu\text{F}$  capacitor to AGND. Minimize lead lengths to reduce lead inductance.

### Grounding and Layout Considerations

Digital and AC transient signals on AGND can create noise at the output. Connect AGND to the highest quality ground available. Use proper grounding techniques, such as a multilayer board with a low-inductance ground plane. Carefully lay out the traces between channels to reduce AC cross-coupling and crosstalk. Wire-wrapped boards and sockets are not recommended. If noise becomes an issue, shielding may be required.

# Low-Power, Dual, 12-Bit Voltage-Output DACs with Serial Interface

## Pin Configuration

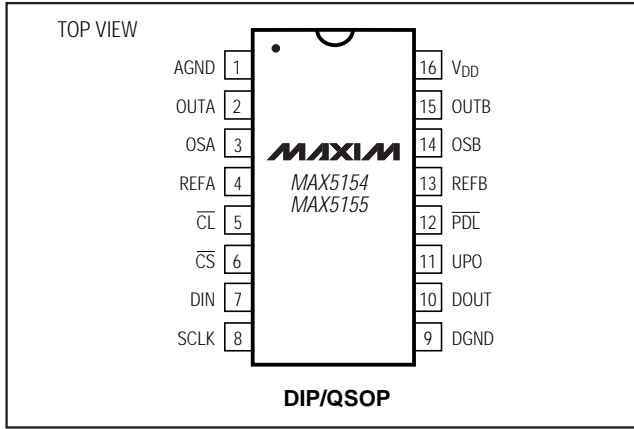

## Ordering Information (continued)

PART	TEMP. RANGE	PIN-PACKAGE	INL (LSB)
MAX5154AEPE	-40°C to +85°C	16 Plastic DIP	±1/2
MAX5154BEPE	-40°C to +85°C	16 Plastic DIP	±1
MAX5154AEPE	-40°C to +85°C	16 QSOP	±1/2
MAX5154BEPE	-40°C to +85°C	16 QSOP	±1
MAX5154BMJE	-55°C to +125°C	16 CERDIP*	±1
<b>MAX5155ACPE</b>	0°C to +70°C	16 Plastic DIP	±1
MAX5155BCPE	0°C to +70°C	16 Plastic DIP	±2
MAX5155ACEE	0°C to +70°C	16 QSOP	±1
MAX5155BCEE	0°C to +70°C	16 QSOP	±2
MAX5155AEPE	-40°C to +85°C	16 Plastic DIP	±1
MAX5155BEPE	-40°C to +85°C	16 Plastic DIP	±2
MAX5155AEPE	-40°C to +85°C	16 QSOP	±1
MAX5155BEPE	-40°C to +85°C	16 QSOP	±2
MAX5155BMJE	-55°C to +125°C	16 CERDIP*	±2

## Chip Information

TRANSISTOR COUNT: 3053

SUBSTRATE CONNECTED TO AGND

\*Contact factory for availability.

## Package Information

DIM	INCHES		MILLIMETERS	
	MIN	MAX	MIN	MAX
A	.061	.068	1.55	1.73
A1	.004	.0098	0.127	0.25
A2	.055	.061	1.40	1.55
B	.008	.012	0.20	0.31
C	.0075	.0098	0.19	0.25
D	SEE VARIATIONS			
E	.150	.157	3.81	3.99
e	.025 BSC		0.635 BSC	
H	.230	.244	5.84	6.20
h	.010	.016	0.25	0.41
L	.016	.035	0.41	0.89
N	SEE VARIATIONS			
S	SEE VARIATIONS			
?	0°	8°	0°	8°

NOTES:  
 1. D & E DO NOT INCLUDE MOLD FLASH OR PROTRUSIONS  
 2. MOLD FLASH OR PROTRUSIONS NOT TO EXCEED .006"  
 3. CONTROLLING DIMENSIONS: INCHES

VARIATIONS:

	INCHES		MILLIMETERS		N
	MIN.	MAX.	MIN.	MAX.	
D	.189	.196	4.80	4.98	16
S	.0020	.0070	0.05	0.18	
D	.337	.344	8.56	8.74	20
S	.0500	.0550	1.27	1.40	
D	.337	.344	8.56	8.74	24
S	.0250	.0300	0.64	0.76	
D	.386	.393	9.80	9.98	28
S	.0250	.0300	0.64	0.76	

MAXIM  
 PROPRIETARY INFORMATION  
 TITLE:  
 PACKAGE OUTLINE, QSOP, .150 INCH, .025" LEAD PITCH  
 APPROVAL: \_\_\_\_\_ DOCUMENT CONTROL NO: 21-0055 REV: A 1/1

Maxim cannot assume responsibility for use of any circuitry other than circuitry entirely embodied in a Maxim product. No circuit patent licenses are implied. Maxim reserves the right to change the circuitry and specifications without notice at any time.

16 Maxim Integrated Products, 120 San Gabriel Drive, Sunnyvale, CA 94086 408-737-7600

© 1997 Maxim Integrated Products

Printed USA

MAXIM is a registered trademark of Maxim Integrated Products.