



STEVAL-ICB003V1

Smart touchpanel interface based on the STMPE1208S, STLED316S and STM8S

Data brief

Features

- 4 x 7-segment LED display
- 8 touchkeys
- 8 x 3 mm LEDs
- 1 bi-color LED for on/standby indication
- 1 interrupt assert LED
- On-board buzzer
- Rotary encoder for up/down functions
- Standby management for low power operation
- Relay for switching host power
- Power supply connector for single 9 V supply
- Wakeup feature from system standby
- Embedded in-circuit programming capability through SWIM interface
- Water level sensor input for 38-43 kHz water sensors
- RoHS compliant

Description

The STEVAL-ICB003V1 demonstration board is a general-purpose front panel solution suitable for white goods, utilizing a TLED316S LED driver, STMPE1208S capacitive touch sensor and an STM8S207K6 microcontroller from the STM8 series of 8 bit microcontrollers.

The purpose of the board is to demonstrate the capabilities of ST's STLED316S, STMPE1208S and STM8S devices in a sophisticated front panel application targeted at the front panel market segment for DVD players, DVD recorders, set-top boxes, washing machines, etc., while keeping system cost as low as possible.

The design focuses on 3 key areas: standby management for low power consumption, general touchkey and rotary encoder input and water level sensing of a 38-43 kHz output from a water level sensor.



To increase versatility, the design includes features such as rotary encoder interface, power management and a logic level input for a water level sensor.

1 Schematic circuits

Figure 1. Control and LED display

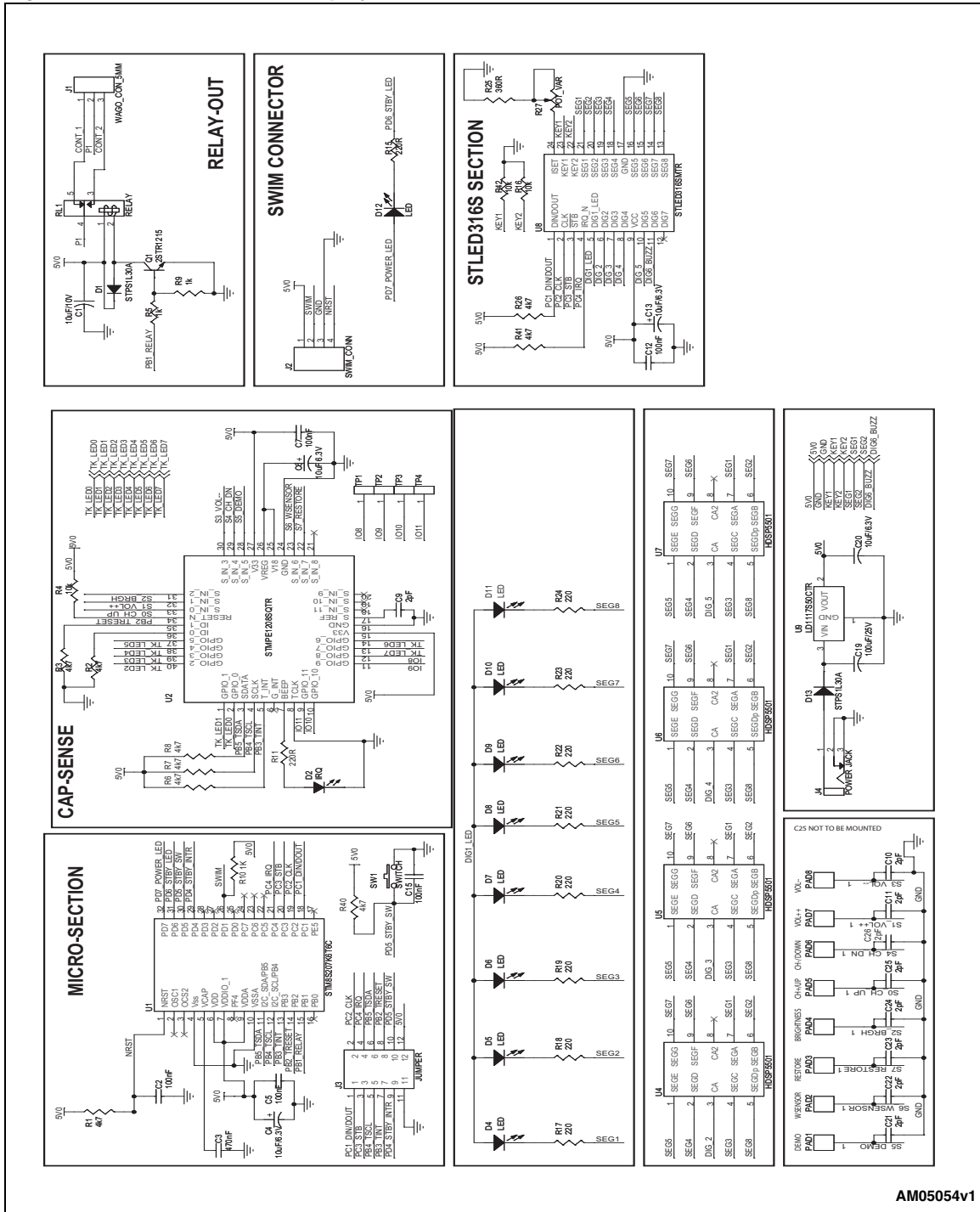
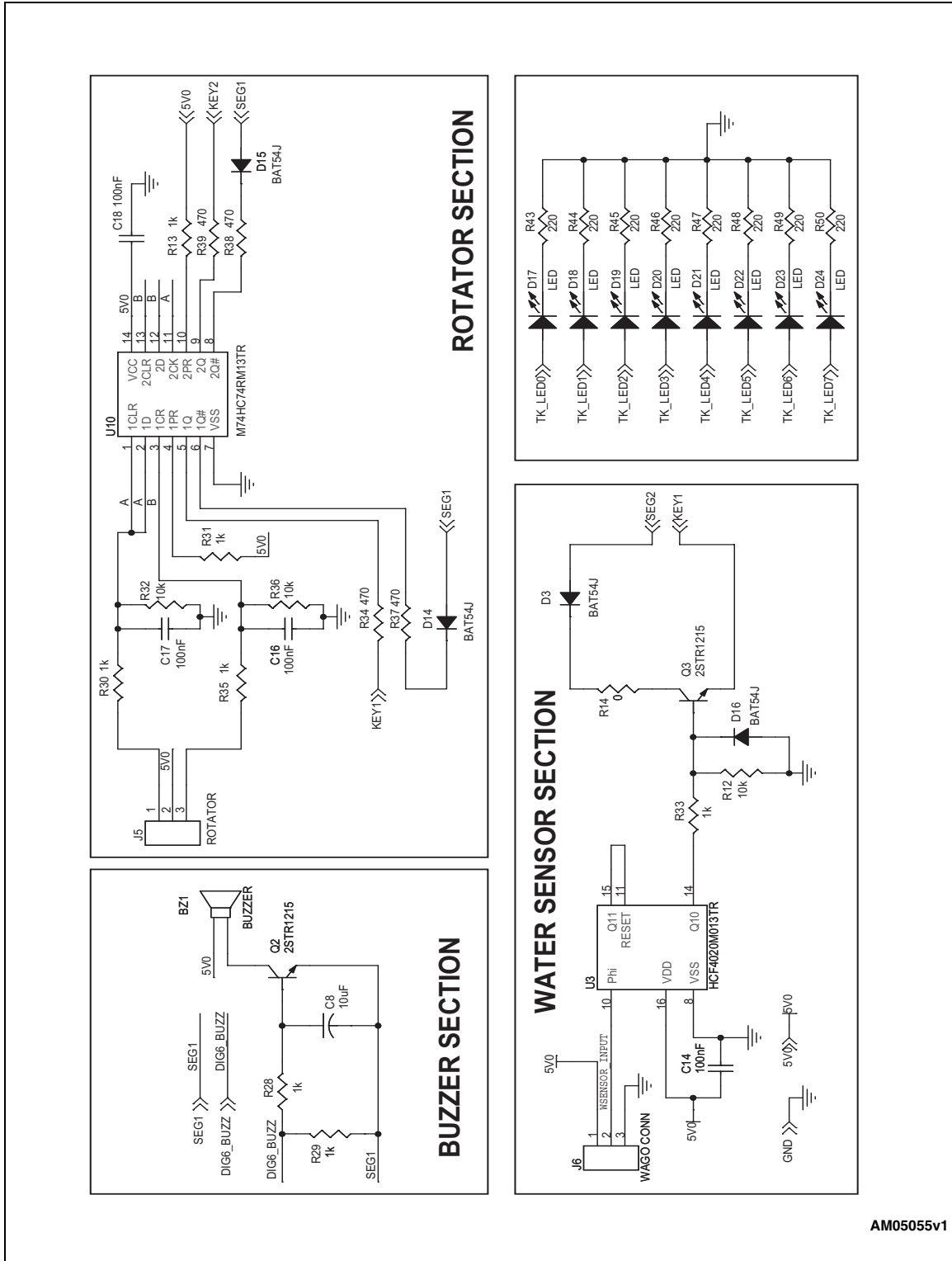

Figure 2. Peripherals schematics



AM05055v1

2 Revision history

Table 1. Document revision history

Date	Revision	Changes
13-Jul-2009	1	Initial release.

Please Read Carefully:

Information in this document is provided solely in connection with ST products. STMicroelectronics NV and its subsidiaries ("ST") reserve the right to make changes, corrections, modifications or improvements, to this document, and the products and services described herein at any time, without notice.

All ST products are sold pursuant to ST's terms and conditions of sale.

Purchasers are solely responsible for the choice, selection and use of the ST products and services described herein, and ST assumes no liability whatsoever relating to the choice, selection or use of the ST products and services described herein.

No license, express or implied, by estoppel or otherwise, to any intellectual property rights is granted under this document. If any part of this document refers to any third party products or services it shall not be deemed a license grant by ST for the use of such third party products or services, or any intellectual property contained therein or considered as a warranty covering the use in any manner whatsoever of such third party products or services or any intellectual property contained therein.

UNLESS OTHERWISE SET FORTH IN ST'S TERMS AND CONDITIONS OF SALE ST DISCLAIMS ANY EXPRESS OR IMPLIED WARRANTY WITH RESPECT TO THE USE AND/OR SALE OF ST PRODUCTS INCLUDING WITHOUT LIMITATION IMPLIED WARRANTIES OF MERCHANTABILITY, FITNESS FOR A PARTICULAR PURPOSE (AND THEIR EQUIVALENTS UNDER THE LAWS OF ANY JURISDICTION), OR INFRINGEMENT OF ANY PATENT, COPYRIGHT OR OTHER INTELLECTUAL PROPERTY RIGHT.

UNLESS EXPRESSLY APPROVED IN WRITING BY AN AUTHORIZED ST REPRESENTATIVE, ST PRODUCTS ARE NOT RECOMMENDED, AUTHORIZED OR WARRANTED FOR USE IN MILITARY, AIR CRAFT, SPACE, LIFE SAVING, OR LIFE SUSTAINING APPLICATIONS, NOR IN PRODUCTS OR SYSTEMS WHERE FAILURE OR MALFUNCTION MAY RESULT IN PERSONAL INJURY, DEATH, OR SEVERE PROPERTY OR ENVIRONMENTAL DAMAGE. ST PRODUCTS WHICH ARE NOT SPECIFIED AS "AUTOMOTIVE GRADE" MAY ONLY BE USED IN AUTOMOTIVE APPLICATIONS AT USER'S OWN RISK.

Resale of ST products with provisions different from the statements and/or technical features set forth in this document shall immediately void any warranty granted by ST for the ST product or service described herein and shall not create or extend in any manner whatsoever, any liability of ST.

ST and the ST logo are trademarks or registered trademarks of ST in various countries.

Information in this document supersedes and replaces all information previously supplied.

The ST logo is a registered trademark of STMicroelectronics. All other names are the property of their respective owners.

© 2009 STMicroelectronics - All rights reserved

STMicroelectronics group of companies

Australia - Belgium - Brazil - Canada - China - Czech Republic - Finland - France - Germany - Hong Kong - India - Israel - Italy - Japan - Malaysia - Malta - Morocco - Philippines - Singapore - Spain - Sweden - Switzerland - United Kingdom - United States of America

www.st.com

