

# CLC5958

## 14-Bit, 52 MSPS A/D Converter

### General Description

The CLC5958 is a monolithic 14-bit, 52 MSPS analog-to-digital converter. The ultra-wide dynamic range and high sample rate of the device make it an excellent choice for wideband receivers found in multi-channel base-stations. The CLC5958 integrates a low distortion track-and-hold amplifier and a 14-bit multi-stage quantizer on a single die. Other features include differential analog inputs, low jitter differential clock inputs, an internal bandgap voltage reference, and CMOS/TTL compatible outputs. The CLC5958 is fabricated on the National ABIC-V 0.8 micron BiCMOS process.

The CLC5958 features a 90 dB spurious free dynamic range (SFDR) and 70 dB signal-to-noise ratio (SNR). The balanced differential analog inputs ensure low even-order distortion, while the differential clock inputs permit the use of balanced clock signals to minimize clock jitter. The 48-pin CSP package provides an extremely small footprint for applications where space is a critical consideration. The package also provides a very low thermal resistance to ambient. The CLC5958 may be operated with a single +5V power supply. Alternatively, an additional supply may be used to program the digital output levels over the range of +3.3V to +5V. Operation over the industrial temperature range of  $-40^{\circ}\text{C}$  to  $+85^{\circ}\text{C}$  is guaranteed. National Semiconductor tests each part to verify compliance with the guaranteed specifications.

### Features

- Ultra-wide dynamic range
- Excellent performance to Nyquist
- IF sampling capability
- Very small package: 48-pin CSP
- Programmable Output Levels: 3.3V to 5V

### Key Specifications

- Sample Rate 52 MSPS
- SFDR 90 dB
- Noise floor  $-72$  dBFS

### Applications

- Multi-channel basestations
- Multi-standard basestations: GSM, WCDMA, DAMPS, etc.
- Smart antenna systems
- Wireless local loop
- Wideband digital communications

### Block Diagram

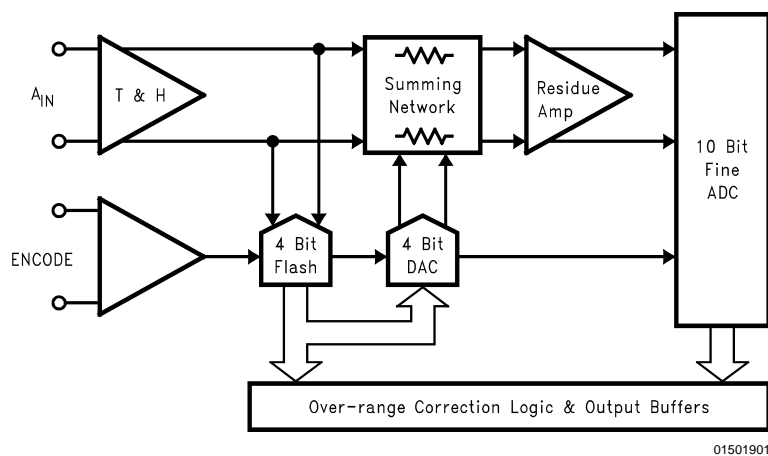

## Pin Configuration

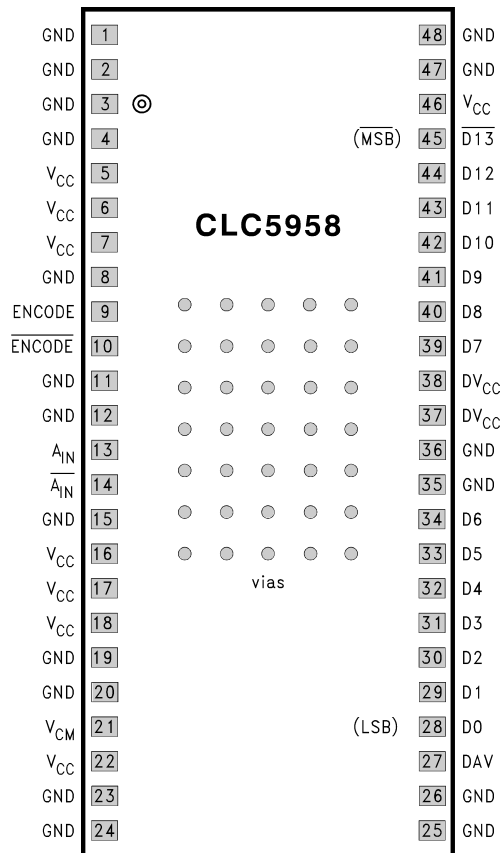

01501902

## Ordering Information

CLC5958SLB	48-Pin CSP
CLC5958PCASM	Evaluation Board

## Pin Descriptions

Pin Name	Pin No.	Description
$A_{IN}$ , $\overline{A}_{IN}$	13, 14	Differential inputs. Self biased at a common mode voltage of +3.25V. The ADC full scale input is 2.048 $V_{PP}$ differential.
ENCODE, $\overline{ENCODE}$	9, 10	Differential clock inputs. ENCODE initiates a new data conversion cycle on each rising edge. Clock signals may be sinusoidal or square waves with PECL encode levels. The falling edge of ENCODE clocks internal pipeline stages.
$D0$ – $\overline{D13}$	28–34, 39–45	Digital data outputs. CMOS and TTL compatible. D0 is the LSB and $\overline{D13}$ is the inverted MSB. Output coding is two's complement.
DAV	27	Data valid. The rising edge of this signal occurs when output data is valid and may be used to latch data into following circuitry.
$V_{CM}$	21	Internal analog input common mode voltage reference. Nominally +3.25V. Can be used to establish the analog input common mode voltage for DC coupled applications (DC coupling not recommended, see applications section).
GND	1–4, 8, 11, 12, 15, 19, 20, 23–26, 35, 36, 47, 48 and vias	Circuit ground.
$V_{CC}$	5–7, 16–18, 22, 46	+5V power supply. Bypass each group of supply pins to ground with a 0.01 $\mu F$ capacitor.
$DV_{CC}$	37, 38	+3.3V to +5V power supply for the digital outputs. Establishes the high output level for the digital outputs. Bypass to ground with a 0.1 $\mu F$ capacitor.

**Absolute Maximum Ratings** (Note 1)

If Military/Aerospace specified devices are required, please contact the National Semiconductor Sales Office/Distributors for availability and specifications.

Positive Supply Voltage ( $V_{CC}$ )	-0.5V to +6V
Differential Voltage between any Two Grounds	<200 mV
Analog Input Voltage Range	GND to $V_{CC}$
Digital Input Voltage Range	-0.5V to + $V_{CC}$
Output Short Circuit Duration (one-pin to ground)	Infinite
Junction Temperature	175°C
Storage Temperature Range	-65°C to +150°C
Lead Solder Duration (+240°C)	5 sec.
ESD tolerance human body model	2000V
machine model	200V

**Recommended Operating Conditions**

Positive Supply Voltage ( $V_{CC}$ )	+5V ±5%
Analog Input Voltage Range	2.048 $V_{PP}$ diff.
Input Coupling	AC
Operating Temperature Range	-40°C to +85°C
Digital Output Supply Voltage ( $DV_{CC}$ )	+3.3V ±5%
Analog Input Common Mode Voltage	$V_{CM}$ ±0.025V

**Package Thermal Resistance**

Package	$\theta_{JA}$	$\theta_{JC}$
48-Pin CSP	39°C/W	5°C/W

**Reliability Information**

Transistor Count	10,000
------------------	--------

**Converter Electrical Characteristics**

The following specifications apply for  $V_{CC} = +5V$ ,  $DV_{CC} = +3.3V$ , 52 MSPS. **Boldface limits apply for  $T_A = T_{min} = -40^\circ C$  to  $T_{max} = +85^\circ C$** , all other limits  $T_A = 25^\circ C$  (Note 4).

Symbol	Parameter	Conditions	Min	Typ	Max	Units
	<b>RESOLUTION</b> (Note 2) (Note 3)			14		Bits
	<b>DIFFERENTIAL INPUT VOLTAGE RANGE</b>			2.048		V
	<b>MAXIMUM CONVERSION RATE</b> (Note 2) (Note 3)		<b>52</b>	65		MSPS
<b>SNR</b>	Signal-to-Noise Ratio (Note 2)	$f_{IN} = 10$ MHz, $A_{IN} = -0.6$ dBFS	69	71		dBFS
<b>SFDR</b>	Spurious-Free Dynamic Range (Note 2)	$f_{IN} = 10$ MHz, $A_{IN} = -0.6$ dBFS	80	90		dB
	SFDR Excluding 2 <sup>nd</sup> and 3 <sup>rd</sup> Harmonics (Note 2)	$f_{IN} = 10$ MHz, $A_{IN} = -0.6$ dBFS	85	92		dB
	<b>NO MISSING CODES</b> (Note 2)	$f_{IN} = 10$ MHz, $A_{IN} = -0.6$ dBFS	Guaranteed			
<b>NOISE AND DISTORTION</b>						
	Noise Floor (Note 6)	$f_{IN} = 5$ MHz, $A_{IN} = -1$ dBFS		-71.0		dBFS
		$f_{IN} = 5$ MHz, $A_{IN} = -20$ dBFS		-72.0		dBFS
	2 <sup>nd</sup> and 3 <sup>rd</sup> Harmonic Distortion (w/o dither)	$f_{IN} = 5$ MHz, $A_{IN} = -1$ dBFS		-90		dBFS
		$f_{IN} = 20$ MHz, $A_{IN} = -1$ dBFS		-87		dBFS
		$f_{IN} = 70$ MHz, $A_{IN} = -3$ dBFS		-78		dBFS
	Next Worst Harmonic Distortion (w/o dither)(Note 7)	$f_{IN} = 5$ MHz, $A_{IN} = -1$ dBFS		-92		dBFS
		$f_{IN} = 20$ MHz, $A_{IN} = -1$ dBFS		-90		dBFS
		$f_{IN} = 70$ MHz, $A_{IN} = -3$ dBFS		-90		dBFS
	Worst Harmonic Distortion (with dither) (Note 8)	$f_{IN} = 5$ MHz, $A_{IN} = -6$ dBFS		-95		dBFS
		$f_{IN} = 20$ MHz, $A_{IN} = -6$ dBFS		-95		dBFS
		$f_{IN} = 70$ MHz, $A_{IN} = -6$ dBFS		-82		dBFS
		$f_{IN} = 70$ MHz (2 <sup>nd</sup> and 3 <sup>rd</sup> excluded), $A_{IN} = -6$ dBFS		-95		dBFS
<b>IMD</b>	2-Tone IM Distortion (w/o dither)	$f_{IN1} = 12$ MHz, $f_{IN2} = 15$ MHz, $A_{IN1} = A_{IN2} = -7$ dBFS		-100		dBFS
<b>SINAD</b>	Signal-to-Noise and Distortion (w/o dither)	$f_{IN} = 5$ MHz, $A_{IN} = -1$ dBFS		69		dB
<b>CLOCK RELATED SPURIOUS TONES</b>						
	fs/8, fs/4			-95		dBFS

## Converter Electrical Characteristics (Continued)

The following specifications apply for  $V_{CC} = +5V$ ,  $DV_{CC} = +3.3V$ , 52 MSPS. **Boldface limits apply for  $T_A = T_{min} = -40^{\circ}C$  to  $T_{max} = +85^{\circ}C$** , all other limits  $T_A = 25^{\circ}C$  (Note 4).

Symbol	Parameter	Conditions	Min	Typ	Max	Units
	Next Worst Clock Spur (Note 9)			-100		dBFS
	Calibration Side-band Coefficient (Note 10)			100e-6		
<b>DC ACCURACY AND PERFORMANCE</b>						
DNL	Differential Non-Linearity			±0.3		LSB
INL	Integral Non-Linearity			±1.5		LSB
	Offset Error			±2.0		mV
	Gain Error			2		% of FS
<b>DYNAMIC PERFORMANCE</b>						
BW	Large-Signal Bandwidth			210		MHz
$t_{AJ}$	Aperture Jitter			0.5		ps(rms)
<b>ANALOG INPUT CHARACTERISTICS</b>						
$R_{IN}$ (SE)	Single Ended Input Resistance			500		$\Omega$
$C_{IN}$ (SE)	Single Ended Capacitance			3.6		pF
<b>ENCODE INPUT CHARACTERISTICS</b>						
$V_{IH}$	Logic Input High Voltage (Note 5) (Note 11)		<b>3.9</b>		<b>4.5</b>	V
$V_{IL}$	Logic Input Low Voltage (Note 5) (Note 11)		<b>3.0</b>		<b>3.8</b>	V
	Differential Input Swing (Note 5)		<b>0.2</b>			V
$I_{IL}$	Logic Input Low Current			2		$\mu A$
$I_{IH}$	Logic Input High Current			25		$\mu A$
<b>DIGITAL OUTPUT CHARACTERISTICS</b>						
$V_{OH}$	Logic Output High Voltage (Note 2)	$I_{OH} = 50 \mu A$	3.2			V
$V_{OL}$	Logic Output Low Voltage (Note 2)	$I_{OL} = 50 \mu A$			0.1	V
<b>TIMING</b> ( $C_L = 7pF$ DATA; $18pF$ DAV)						
	Max conversion rate (ENCODE) (Note 2) (Note 3)		<b>52</b>			MSPS
	Min conversion rate (ENCODE)			20		MSPS
$t_P$	Pulse width high (ENCODE) (Note 5)	50% threshold	<b>9.5</b>			ns
$t_M$	Pulse width low (ENCODE) (Note 5)	50% threshold	<b>9.5</b>			ns
$t_{DNV}$	ENCODE rising edge to DATA not valid (Note 5)		<b>4.5</b>			ns
$t_{DGV}$	ENCODE rising edge to DATA guaranteed valid (Note 5)				<b>13.0</b>	ns
$t_{DAV}$	Falling ENCODE to rising DAV delay (Note 5)	50% threshold	<b>7.7</b>		<b>13.5</b>	ns
$t_S$	DATA setup time before rising DAV (Note 5)		<b><math>t_P - 0.8</math></b>			ns
$t_H$	DATA hold time after rising DAV (Note 5)		<b><math>t_M - 4.7</math></b>			ns
	Pipeline latency			3.0		clk cycle
$t_A$	Effective aperture delay			-0.2		ns
<b>SUPPLY CHARACTERISTICS</b>						
	+5V Supply Current ( $V_{CC}$ ) (Note 2) (Note 3)			260	<b>300</b>	mA

## Converter Electrical Characteristics (Continued)

The following specifications apply for  $V_{CC} = +5V$ ,  $DV_{CC} = +3.3V$ , 52 MSPS. **Boldface limits apply for  $T_A = T_{min} = -40^{\circ}C$  to  $T_{max} = +85^{\circ}C$** , all other limits  $T_A = 25^{\circ}C$  (Note 4).

Symbol	Parameter	Conditions	Min	Typ	Max	Units
	+3.3V Supply Current ( $DV_{CC}$ ) (Note 2) (Note 3)			32	<b>40</b>	mA
	Power Dissipation			1.4		W
	$V_{CC}$ Power Supply Rejection Ratio			0.75		mV/V

**Note 1:** "Absolute Maximum Ratings" are limiting values, to be applied individually, and beyond which the serviceability of the circuit may be impaired. Functional operability under any of these conditions is not necessarily implied. Exposure to maximum ratings for extended periods may affect device reliability.

**Note 2:** These parameters are 100% tested at 25°C.

**Note 3:** These parameters are sample tested at full temperature range.

**Note 4:** Typical specifications are based on the mean test values of deliverable converters from the first three diffusion lots.

**Note 5:** Values guaranteed based on characterization and simulation.

**Note 6:** Harmonics and clock spurious are removed in noise measurements.

**Note 7:** 4<sup>th</sup> or higher harmonic.

**Note 8:** Low frequency dither injected in the DC to 500 kHz band.

**Note 9:** Next worst clock spur is a subharmonic of  $f_s$ , but not  $f_s/8$  or  $f_s/4$ . See text on spurious.

**Note 10:** See text on calibration sidebands in the application information section.

**Note 11:** Encode levels are referenced to  $V_{CC}$ , i.e., the minimum  $V_{IH}$  value is 1.1V below  $V_{CC}$ , and the maximum  $V_{IH}$  value is 0.5V below  $V_{CC}$ .

**Typical Performance Characteristics** ( $V_{CC} = +5V$ ), 52 MSPS; unless specified

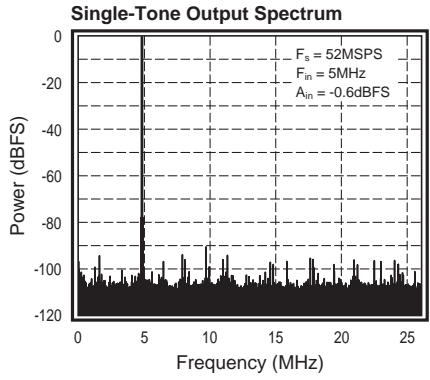

01501903

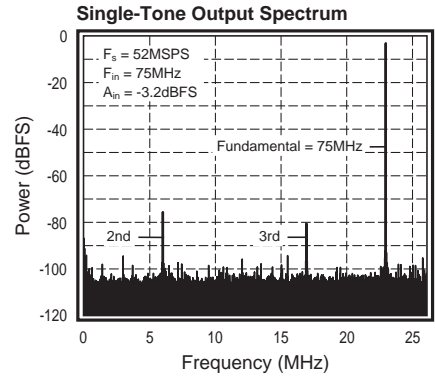

01501904

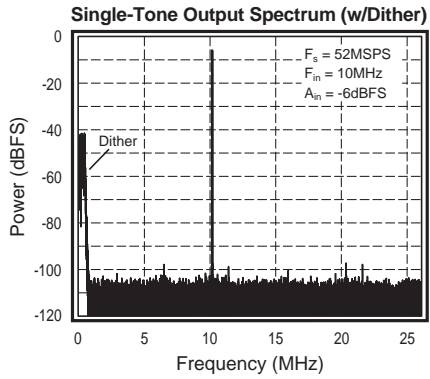

01501905

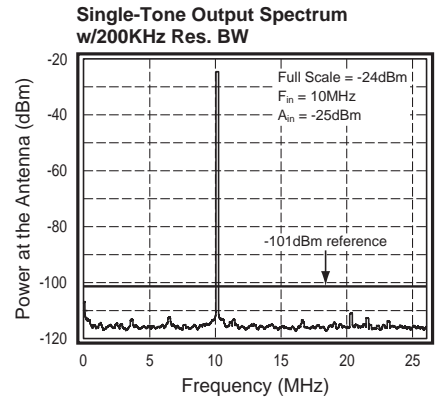

01501906

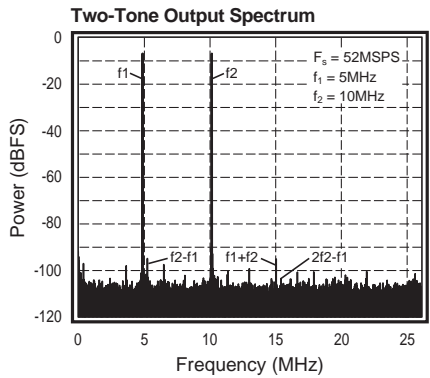

01501907

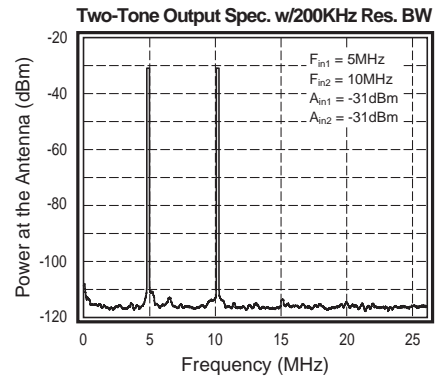

01501908

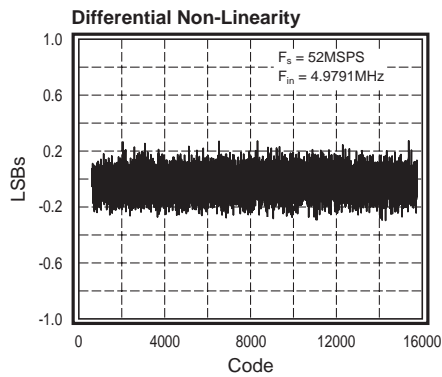

01501909

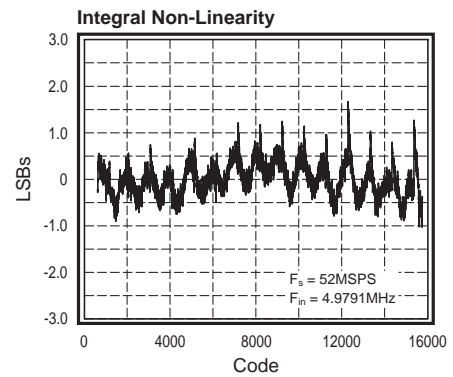

01501910

**Typical Performance Characteristics** ( $V_{CC} = +5V$ ), 52 MSPS; unless specified (Continued)

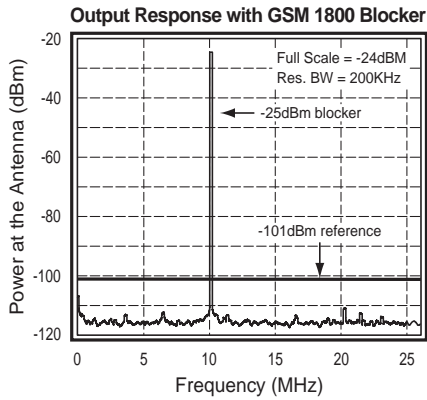

01501934

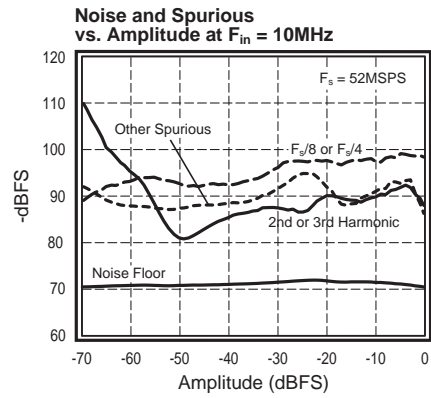

01501911

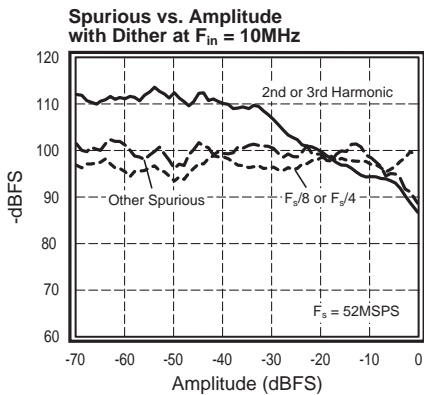

01501912

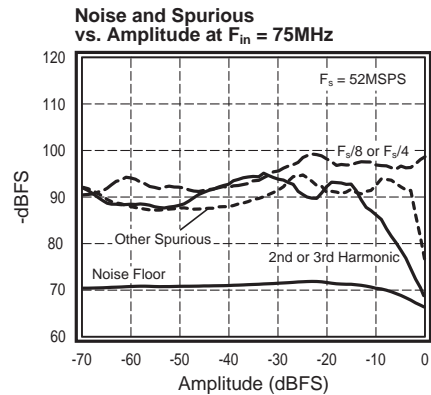

01501913

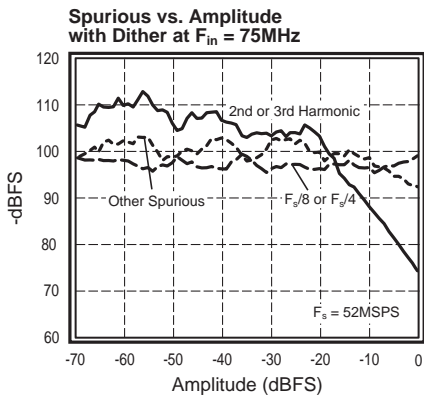

01501914

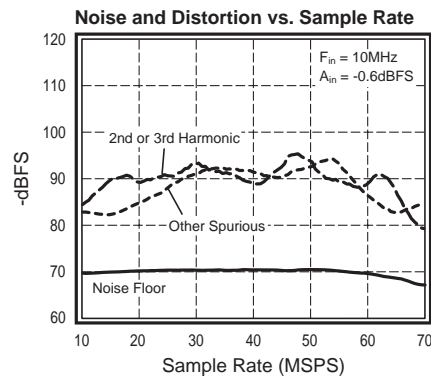

01501915

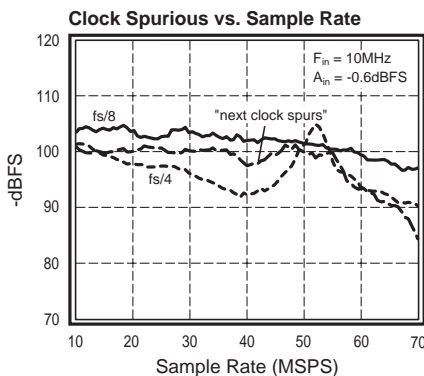

01501916

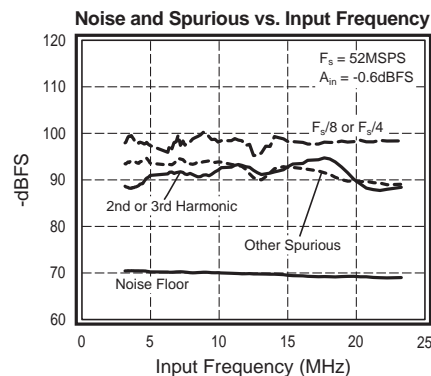

01501917

**Typical Performance Characteristics** ( $V_{CC} = +5V$ ), 52 MSPS; unless specified (Continued)

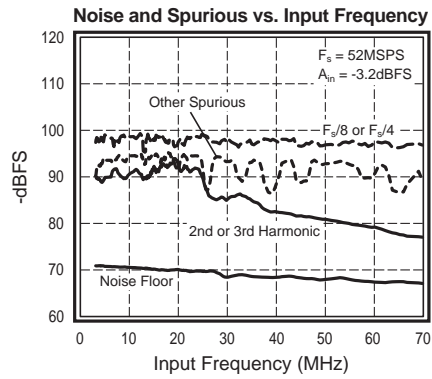

01501918

**Timing Diagram**

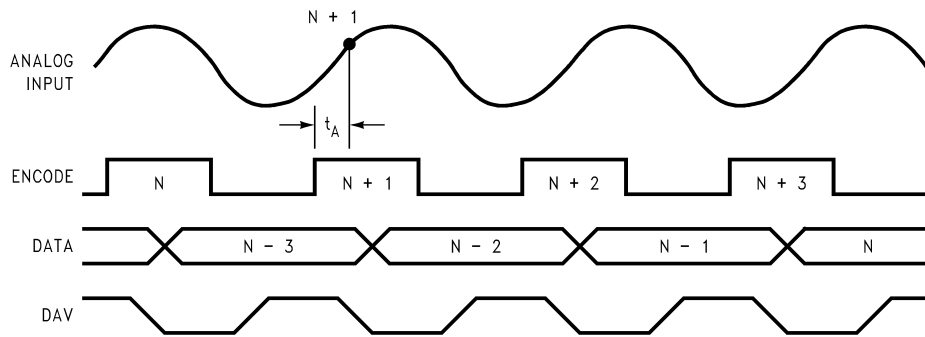

01501935

**CLC5958 Aperture Delay Diagram**  
 $t_A$ : Effective Aperture Delay Nominally - 0.2ns

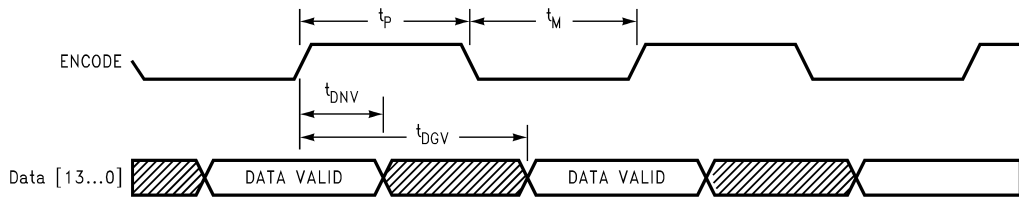

01501936

**CLC5958 ENCODE to Data Timing Diagram**

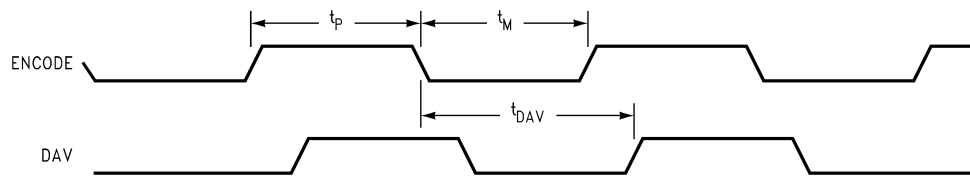

01501937

**CLC5958 ENCODE to DAV Timing Diagram**

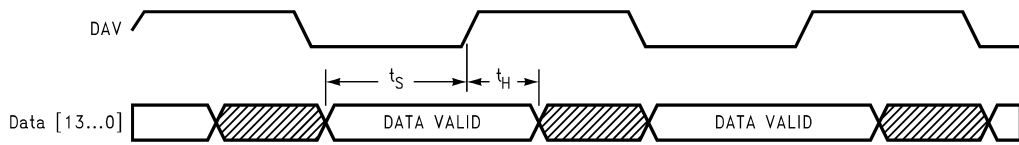

01501919

**CLC5958 DAV to Data Timing Diagram**



## CLC5958 Application Information

### Driving the Analog Inputs

The differential analog inputs,  $A_{IN}$  and  $\overline{A_{IN}}$ , are biased from an internal 3.25V reference (a 2.4V bandgap reference plus a diode) through an on-chip resistance of 500 $\Omega$ . This bias voltage is set for optimum performance, and varies with temperature. Since DC coupling the inputs overrides the internal common mode voltage, it is recommended that the inputs to the CLC5958 be AC coupled whenever possible. The time constant of the input coupling network must be greater than 1  $\mu$ s to minimize distortion due to nonlinear input bias currents. Additionally, the common mode source impedance should be less than 100 $\Omega$  at the sample rate.

If DC coupling is required, then the  $V_{CM}$  output may be used to establish the input common mode voltage. The CLC5958 samples the common mode voltage at the internal track-and-hold output and servos the  $V_{CM}$  output to establish the optimum common mode potential at the track-and-hold. It is possible to use the  $V_{CM}$  output to construct an external servo loop.

Figure 1 illustrates one input coupling method. The transformer provides noiseless single-ended to differential conversion. The two 50 $\Omega$  resistors in the secondary define the input impedance and provide a low common mode source impedance through the bypass capacitors.

Alternatively, the inputs can be driven using a differential amplifier as shown in Figure 2.

The network of Figure 2 uses a simple RC low-pass filter to roll off the noise of the differential amplifier. The network has a cutoff frequency of 40 MHz. Different noise filter designs are required for different applications. For example, an IF application would require a band-pass noise filter.

The analog input lines should be routed close together so that any coupling from other sources is common mode.

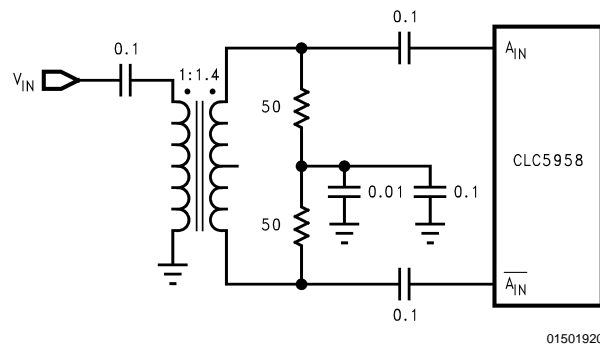

FIGURE 1. Input Coupling

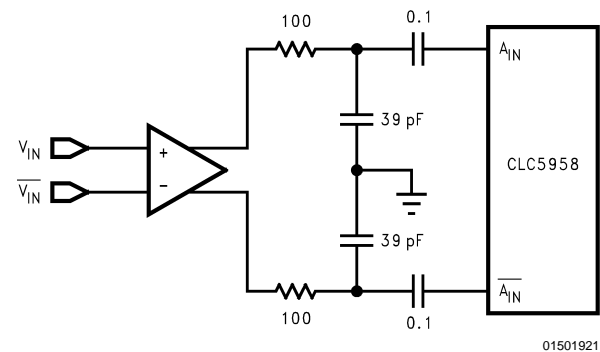

FIGURE 2. Differential Amplifier

### Driving the ENCODE Inputs

The ENCODE and  $\overline{\text{ENCODE}}$  inputs are differential clock inputs that are referenced to  $V_{CC}$ . They may be driven with PECL input levels. Alternatively they may be driven with a differential input (e.g. a sine input) that is centered at 1.2V below  $V_{CC}$  and which meets the min and max ratings for  $V_{IL}$  and  $V_{IH}$ . Low noise differential clock signals provide the best SNR performance for the converter.

The ENCODE inputs are not self-biasing, so a DC bias current path must be provided to each of the inputs.

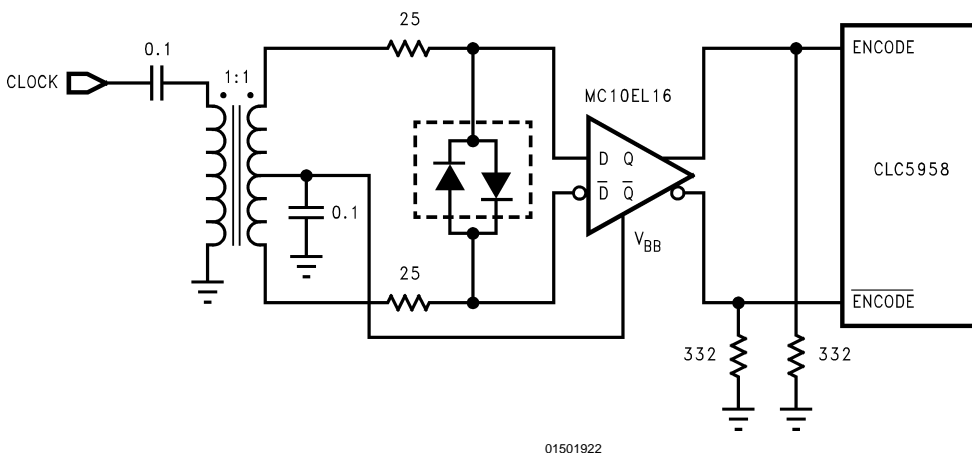

FIGURE 3. Encode Inputs

Figure 3 shows one method of driving the encode inputs.

## CLC5958 Application Information

(Continued)

The transformer converts the single-ended clock signal to a differential signal. The center-tap of the secondary is biased by the  $V_{BB}$  potential of the ECL buffer. The diodes in the secondary limit the input swing to the buffer.

Since the encode inputs are close to the analog inputs, it is recommended that the analog inputs be routed on the top of the board directly over a ground plane and that the encode lines be routed on the back of the board and then connected through via to the encode inputs.

### Latching the Output Data

The rising edge of DAV is approximately centered in the data transition window, and may be used to latch the output data. The DAV output has twice the load driving capability of the data outputs so that two latch clock inputs may be driven by this output.

### Routing Output Data Lines

It is recommended that the ground plane be removed under the data output lines to minimize the capacitive loading of these lines. In some systems this may not be permissible because of EMI considerations.

### Harmonics and Clock Spurious

Harmonics are created by non-linearity in the track-and-hold and the quantizer. Harmonics that arise from repetitive non-linearities in the quantizer may be reduced by the application of a dither signal.

Transformers and baluns can contribute harmonic distortion, particularly at low frequencies where transformer operation relies on magnetic flux in the core. If a transformer is used to perform single ended to differential conversion at the input, care should be taken in the selection of the transformer.

The clock is internally divided by the CLC5958 in order to generate internal control signals. These divided clocks can contribute spurious energy, principally at  $f_s/4$  and  $f_s/8$ . The clock spurious is typically less than  $-90$  dBFS.

### Calibration Sidebands

The CLC5958 incorporates on-board calibration. The calibration process creates low level sideband spurious close to the carrier and near DC for some input frequencies. In most applications these sidebands will not be an issue. The sidebands add negligible power to the carrier and therefore do not reduce sensitivity in receiver applications. Also, the sidebands never fall in adjacent channels with any appreciable power. They may be visible in some very narrow-band applications, and so are documented here for completeness.

The offset of the sidebands relative to the carrier and relative to DC is derived using the equations:

$$n = \text{round} \left( \frac{32 f_{IN}}{f_S} \right) \quad f_{\Delta} = \left| f_{IN} - \frac{n f_S}{32} \right|$$

01501923

where  $f_{\Delta}$  is the sideband offset,  $f_{IN}$  is the input frequency,  $f_S$  is the sample rate, and  $\text{round}(\bullet)$  denotes integer rounding. The magnitude of the sideband relative to the carrier for a full scale input tone is approximated by the equations

$$x = 1024\pi f_{\Delta} / f_S \quad a_{\Delta} = \alpha \left| \frac{\sin(x)}{x} \right|$$

01501924

where  $a_{\Delta}$  is the sideband magnitude relative to the input, and  $\alpha$  is the calibration sideband coefficient. The value of  $\alpha$  rolls off 2 dB per dB as the input amplitude is reduced.

For example, assume the input frequency is 4.8671 MHz and the sample rate is 52 MSPS. Then the sideband offset is derived as follows:

$$n = \text{round} \left( \frac{32 * 4.8671e^6}{52e^6} \right) = 3$$

$$f_{\Delta} = \left| 4.8671e^6 - \frac{3 * 52e^6}{32} \right| = 7.9 \text{ kHz}$$

01501925

If the input is a full scale input, then the magnitude of the sidebands is derived as:

$$x = 1024 \pi 7.9e^3 / 52e^6 = 0.489$$

$$a_{\Delta} = 100e^{-6} * \left| \frac{\sin(0.489)}{0.489} \right| = 96e^{-6} = -80 \text{ dBc}$$

01501926

The sidebands roll off rapidly with increasing sideband offset. For example, if the sideband is offset 200 kHz from the carrier (in an adjacent GSM channel) as opposed to the 7.9 kHz offset from the previous example, the sideband magnitude is reduced to  $-116$  dBc.

Figure 4 shows how the sideband offset frequency varies with input frequency at a sample rate of 52 MSPS.

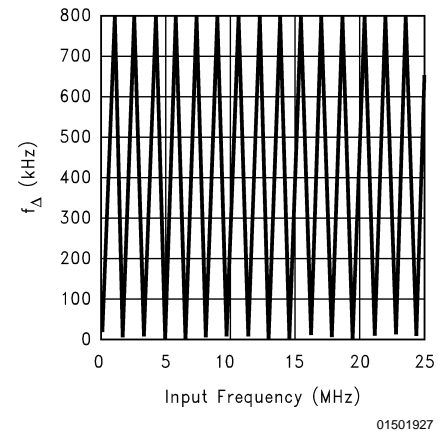
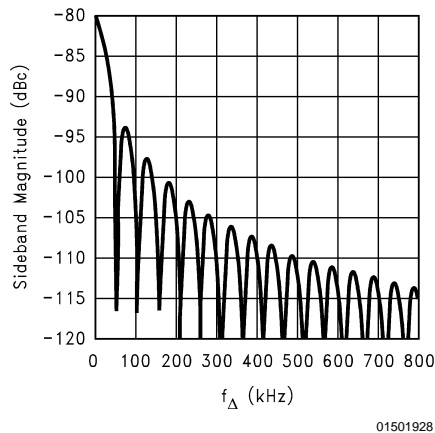

**FIGURE 4. Sideband Offset vs. Input Frequency**

The sideband magnitude is a function of the sideband offset, as illustrated in Figure 5.

## CLC5958 Application Information

(Continued)



**FIGURE 5. Sideband Magnitude vs. Sideband Offset**

### Power Supplies

The  $V_{CC}$  pins supply power to all of the CLC5958 circuitry with the exception of the digital output buffers. The  $DV_{CC}$  pins provide power to the digital output buffers. Each supply pin should be connected to a supply (i.e., do not leave any supply pins floating).

Local groups of supply pins should be bypassed with 0.01  $\mu$ F capacitors. These capacitors should be placed as close to the part as possible. Avoid using via to the ground plane. If vias to the ground plane cannot be avoided, then use multiple vias in close proximity to the bypass capacitor.

The supplies should be bypassed in a manner to prevent supply return currents from flowing near the analog inputs. The evaluation board layout is an example of how to accomplish this.

The digital output buffer supplies ( $DV_{CC}$ ) provide a means for programming the output buffer high level. Supply values

ranging from 3.3V to 5.0V may be applied to these pins. In general, best performance is achieved with  $DV_{CC}$  set to 3.3V.

### Layout Recommendations for the CSP

The 48-lead chip scale package not only provides a small footprint, but also provides an excellent connection to ground. The thermal vias on the bottom of the package also serve as additional ground pads. The solder pad dimensions on the pc board should match the package pads 1:1.

### Soldering Recommendations for the CSP

A 4 mil thick stencil for the solder screen printing is recommended. The suggested IR reflow profile is:

Ramp Up:	2°C/sec
Dwell Time > 183°C:	75 sec
Solder Temperature:	215°C
(max solder temperature):	235°C
Dwell Time @ Max. Temp:	5 sec
Ramp Down:	2°C/sec

### Minimum Conversion Rate

This ADC is optimized for high-speed operation. The internal bipolar track and hold circuits will cause droop errors at low sample rates. The point at which these errors cause a degradation of performance is listed on the specifications page as the minimum conversion rate. If a lower sample rate is desired, the ADC should be clocked at a higher rate, and the output data should be decimated. For example, to obtain a 10MSPS output, the ADC should be clocked at 20MHz, and every other output sample should be used. No significant power savings occurs at lower sample rates, since most of the power is used in analog circuits rather than digital circuits.

# Evaluation Board

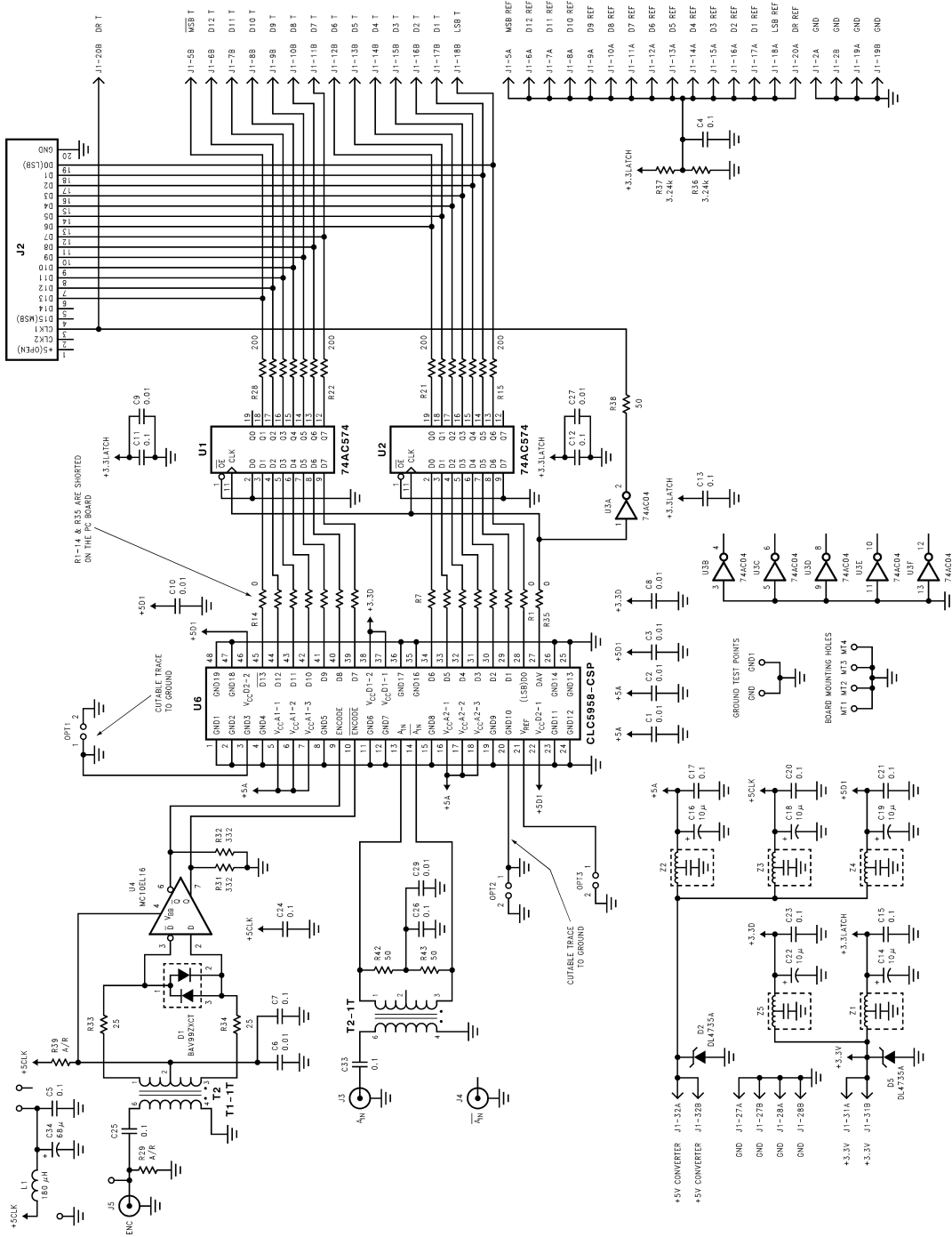

01501929

## Evaluation Board Schematic

Evaluation Board (Continued)

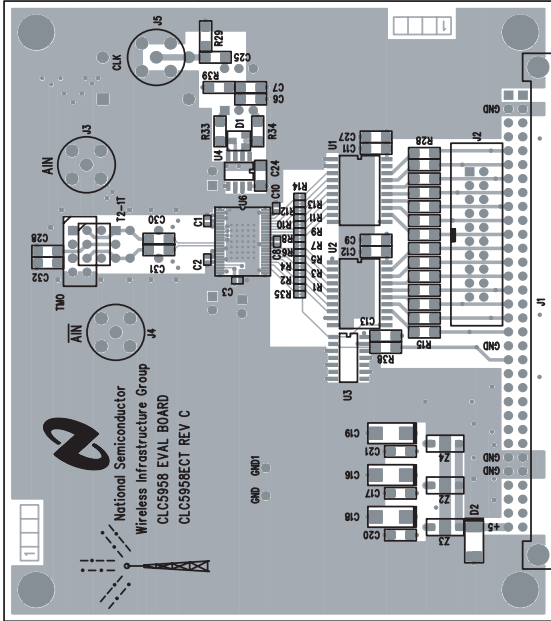

CLC5958PCASM Layer 1

01501930

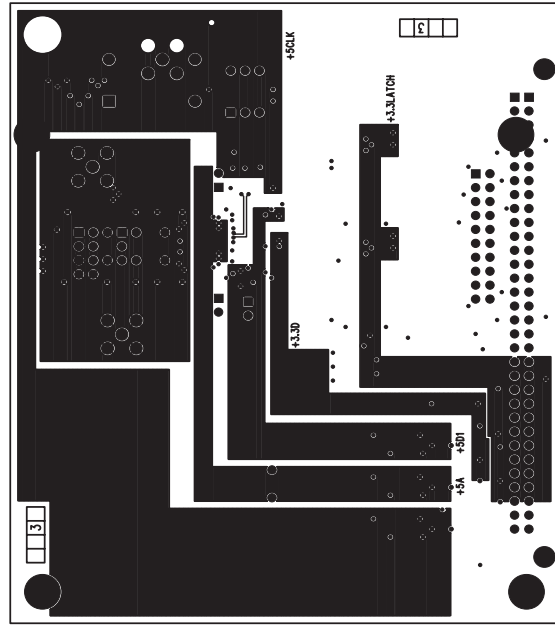

CLC5958PCASM Layer 3

01501931

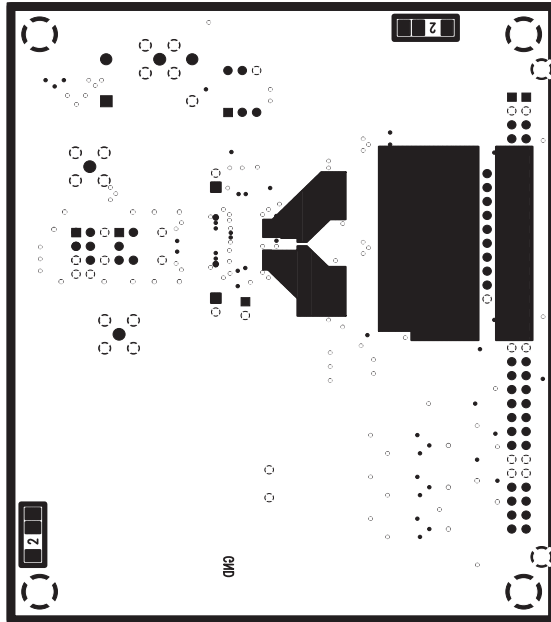

CLC5958PCASM Layer 2

01501932

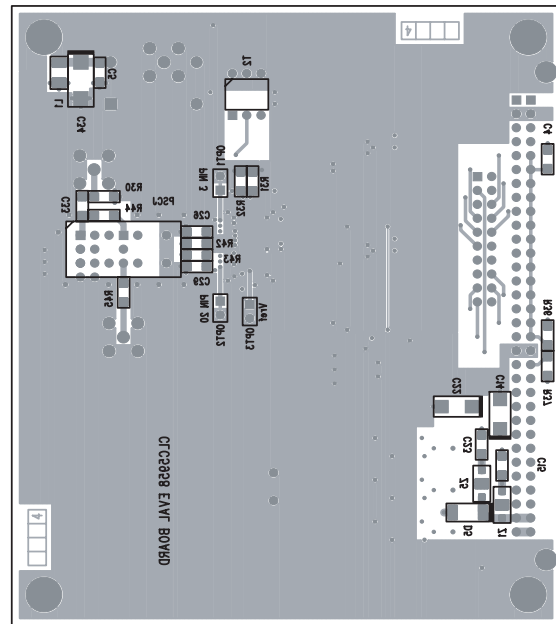

CLC5958PCASM Layer 4

01501933

## Evaluation Printed Circuit Board

The CLC5958 evaluation printed circuit board provides a convenient test bed for rapid evaluation of the CLC5958. It illustrates the proper approach to layout in order to achieve best performance, and provides a performance benchmark.

### Analog Input

The CLC5958 evaluation board is configured to be driven by a single-ended signal at the AIN SMA connector (the  $\overline{\text{AIN}}$  connector is disconnected). The AIN SMA connector should be driven from a  $50\Omega$  source impedance. A full scale input is approximately  $1.4 V_{PP}$  (7 dBm). The single-ended input is converted to a differential input by an on-board transformer.

When performing sine wave testing, it is critical that the input sine wave be filtered to remove harmonics and source noise.

### Encode Input

The CLK SMA connector is the encode input and should also be driven from a  $50\Omega$  source. A low jitter 16 dBm sine wave should be applied at this input. In some cases it may be necessary to band-pass filter the sine wave in order to achieve low jitter.

The single-ended clock input is converted to a differential signal by an on-board transformer and buffered by an ECL buffer.

### Digital Outputs

The digital outputs are available at the Eurocard connector (J1). Data bits D0 through  $\overline{\text{D13}}$  are available at J1 pins 18B through 5B. The data ready signal (labeled DR in the schematic) is available at J1 pin 20B. These outputs are also available at the HP 01650-63203 termination adapter for direct connection to an HP logic analyzer (see evaluation board schematic). The outputs are buffered by 3.3V digital latches. The falling edge of the data ready signal may be used to latch the output data.

### Supply Voltages

Power is sourced to the board through the Eurocard connector. A 5V supply should be connected at J1 pins 32A and 32B. A 3.3V supply should be connected at J1 pins 31A and 31B. The ground return for these supplies is at J1 pins 27A, 27B, 28A, and 28B. It is recommended that low noise linear supplies be used.

**Physical Dimensions** inches (millimeters)

unless otherwise noted

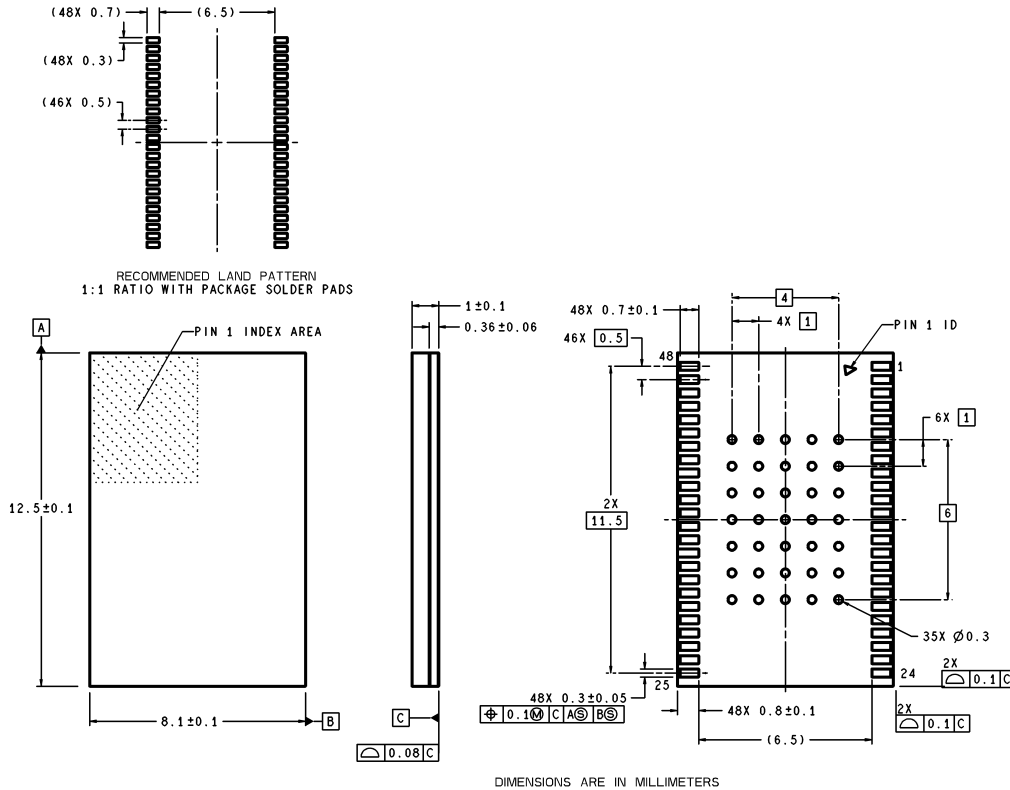

**48-Lead CSP**  
**Order Number CLC5958SLB**  
**NS Package Number SLB048**

**LIFE SUPPORT POLICY**

NATIONAL'S PRODUCTS ARE NOT AUTHORIZED FOR USE AS CRITICAL COMPONENTS IN LIFE SUPPORT DEVICES OR SYSTEMS WITHOUT THE EXPRESS WRITTEN APPROVAL OF THE PRESIDENT AND GENERAL COUNSEL OF NATIONAL SEMICONDUCTOR CORPORATION. As used herein:

1. Life support devices or systems are devices or systems which, (a) are intended for surgical implant into the body, or (b) support or sustain life, and whose failure to perform when properly used in accordance with instructions for use provided in the labeling, can be reasonably expected to result in a significant injury to the user.
2. A critical component is any component of a life support device or system whose failure to perform can be reasonably expected to cause the failure of the life support device or system, or to affect its safety or effectiveness.



**National Semiconductor Corporation**  
Americas  
Tel: 1-800-272-9959  
Fax: 1-800-737-7018  
Email: support@nsc.com  
www.national.com

**National Semiconductor Europe**  
Fax: +49 (0) 180-530 85 86  
Email: europe.support@nsc.com  
Deutsch Tel: +49 (0) 69 9508 6208  
English Tel: +44 (0) 870 24 0 2171  
Français Tel: +33 (0) 1 41 91 8790

**National Semiconductor Asia Pacific Customer Response Group**  
Tel: 65-2544466  
Fax: 65-2504466  
Email: ap.support@nsc.com

**National Semiconductor Japan Ltd.**  
Tel: 81-3-5639-7560  
Fax: 81-3-5639-7507