

# Spread Spectrum Clock Generator

## MB88154A

### MB88154A-101/102/103/111/112/113

#### ■ DESCRIPTION

MB88154A is a clock generator for EMI (Electro Magnetic Interference) reduction. The peak of unnecessary radiation noise (EMI) can be attenuated by making the oscillation frequency slightly modulate periodically with the internal modulator. It corresponds to both of the center spread which modulates input frequency as Middle Centered and down spread which modulates so as not to exceed input frequency.

#### ■ FEATURE

- Input frequency : 16.6 MHz to 80 MHz
- Output frequency: 16.6 MHz to 80 MHz (One time input frequency)
- Modulation rate can select from  $\pm 0.5\%$ ,  $\pm 1.0\%$ ,  $\pm 1.5\%$  or  $- 1.0\%$ ,  $- 2.0\%$ ,  $- 3.0\%$ . (For center spread / down spread.)
- Equipped with crystal oscillation circuit: Range of oscillation 16.6 MHz to 48 MHz
- The external clock can be input: 16.6 MHz to 80 MHz
- Modulation clock output duty : 40% to 60%
- Modulation clock cycle-cycle jitter : Less than 100 ps
- Low current consumption by CMOS process : 5.0 mA (24 MHz : Typ-sample, no load)
- Power supply voltage :  $3.3\text{ V} \pm 0.3\text{ V}$
- Operating temperature :  $- 40\text{ }^{\circ}\text{C}$  to  $+85\text{ }^{\circ}\text{C}$
- Package : 8-pin SOP

# MB88154A

## ■ PRODUCT LINEUP

MB88154A has two kinds of input frequency, and three kinds of modulation type (center/down spread), total six line-ups.

Product	Input/Output frequency	Modulation type
MB88154A-101	50 MHz to 80 MHz	Down
MB88154A-102	33 MHz to 67 MHz	
MB88154A-103	16.6 MHz to 40 MHz	
MB88154A-111	50 MHz to 80 MHz	Center
MB88154A-112	33 MHz to 67 MHz	
MB88154A-113	16.6 MHz to 40 MHz	

## ■ PIN ASSIGNMENT

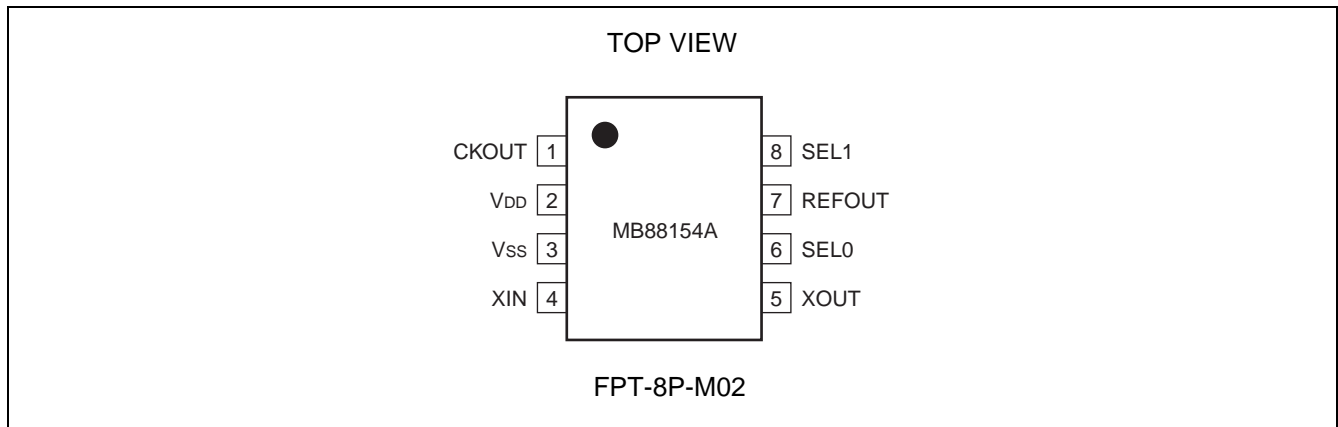

## ■ PIN DESCRIPTION

Pin name	I/O	Pin no.	Description
CKOUT	O	1	Modulated clock output pin
V <sub>DD</sub>	—	2	Power supply voltage pin
V <sub>SS</sub>	—	3	GND pin
XIN	I	4	Crystal resonator connection pin/clock input pin
XOUT	O	5	Crystal resonator connection pin
SEL0	I	6	Modulation rate setting pin
REFOUT	O	7	Non-modulated clock output pin
SEL1	I	8	Modulation rate setting pin

## ■ I/O CIRCUIT TYPE

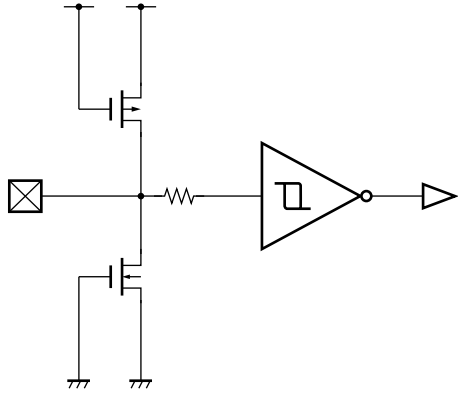
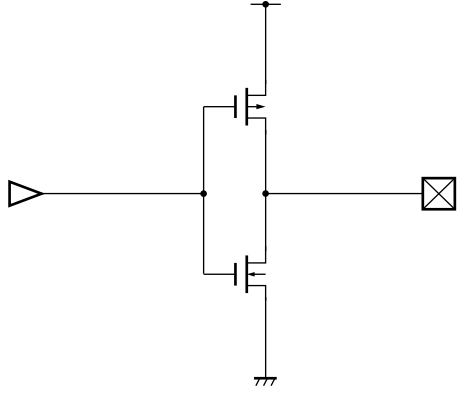
Pin	Circuit type	Remarks
SEL0 SEL1		CMOS hysteresis input
CKOUT REFOUT		<ul style="list-style-type: none"> <li>• CMOS output</li> <li>• <math>I_{OL} = 3 \text{ mA}</math></li> </ul>

Note : For XIN and XOUT pins, refer to “■ OSCILLATION CIRCUIT”

## ■ HANDLING DEVICES

### Preventing Latch-up

A latch-up can occur if, on this device, (a) a voltage higher than  $V_{DD}$  or a voltage lower than  $V_{SS}$  is applied to an input or output pin or (b) a voltage higher than the rating is applied between  $V_{DD}$  pin and  $V_{SS}$  pin. The latch-up, if it occurs, significantly increases the power supply current and may cause thermal destruction of an element. When you use this device, be very careful not to exceed the maximum rating.

### Handling unused pins

Do not leave an unused input pin open, since it may cause a malfunction. Handle by, using a pull-up or pull-down resistor.

Unused output pin should be opened.

### The attention when the external clock is used

Input the clock to XIN pin, and XOUT pin should be opened when you use the external clock.

Please pay attention so that an overshoot and an undershoot do not occur to an input clock of XIN pin.

### Power supply pins

Please design connecting the power supply pin of this device by as low impedance as possible from the current supply source.

We recommend connecting electrolytic capacitor (about 10  $\mu\text{F}$ ) and the ceramic capacitor (about 0.01  $\mu\text{F}$ ) in parallel between  $V_{SS}$  pin and  $V_{DD}$  pin near the device, as a bypass capacitor.

### Oscillation circuit

Noise near the XIN and XOUT pins may cause the device to malfunction. Design printed circuit boards so that electric wiring of XIN or XOUT pin and the resonator do not intersect other wiring.

Design the printed circuit board that surrounds the XIN and XOUT pins with ground.

## ■ BLOCK DIAGRAM

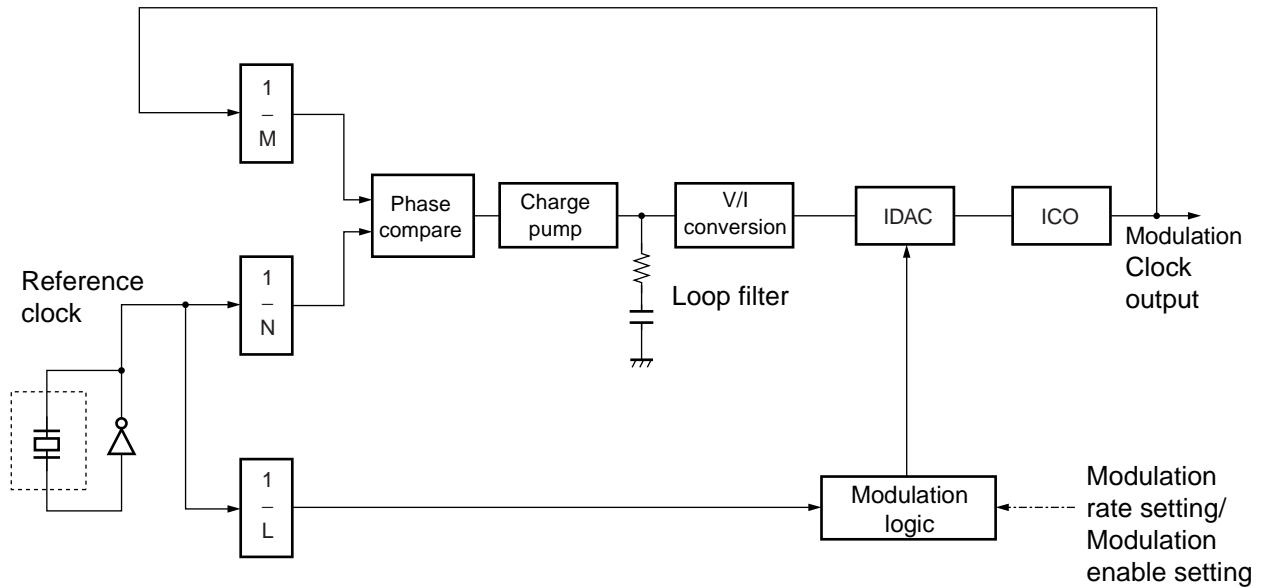
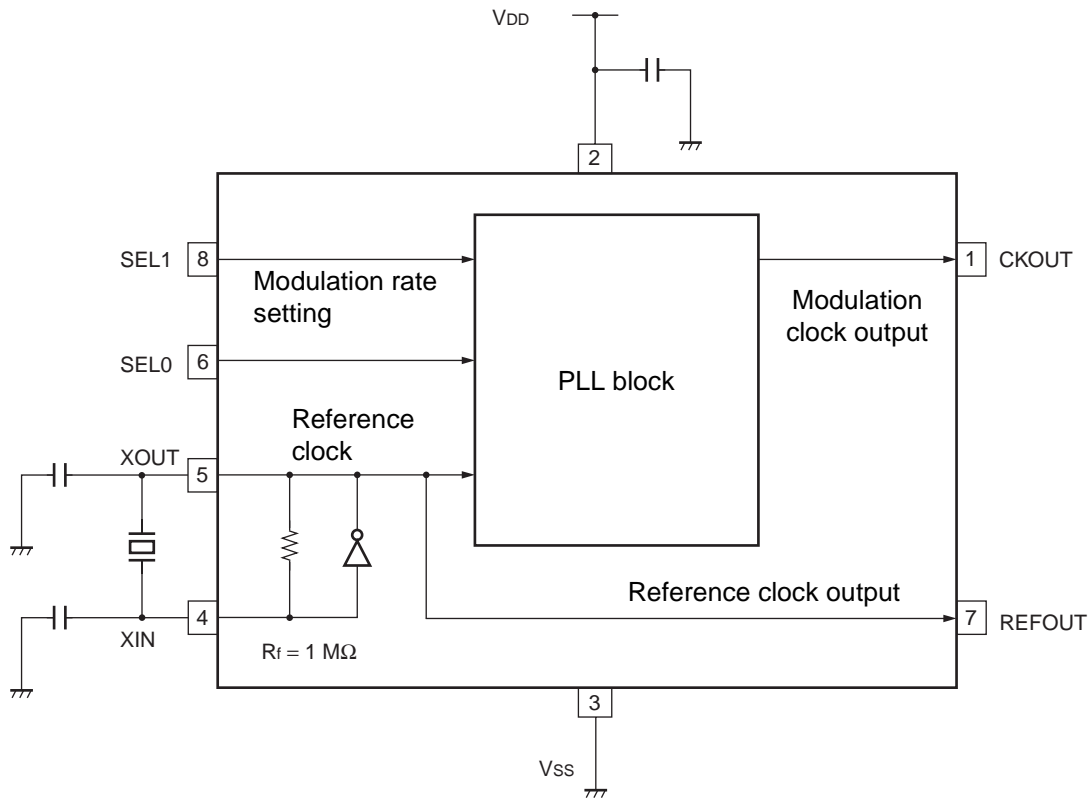

MB88154A PLL block

A glitchless IDAC (current output D/A converter) provides precise modulation, thereby dramatically reducing EMI.

# MB88154A

## ■ PIN SETTING

### SEL 0, SEL 1 Modulation rate setting

SEL1	SEL0	Modulation rate	
		MB88154A-101, MB88154A-102, MB88154A-103	MB88154A-111, MB88154A-112, MB88154A-113
		Down spread	Center spread
L	L	- 1.0%	± 0.5%
L	H	- 2.0%	± 1.0%
H	L	- 3.0%	± 1.5%
H	H	No spread	No spread

Notes :

- The modulation rate can be changed at the level of the pin. Spectrum does not spread when “H” level is set to SEL0 and SEL1 pins. The clock with low jitter can be obtained.
- When changing the modulation rate setting, the stabilization wait time for the modulation clock is required. The stabilization wait time for the modulation clock take the maximum value of “■ ELECTRICAL CHARACTERISTICS • AC Characteristics Lock-Up time”.

#### • Center spread

Spectrum is spread (modulated) by centering on the input frequency.

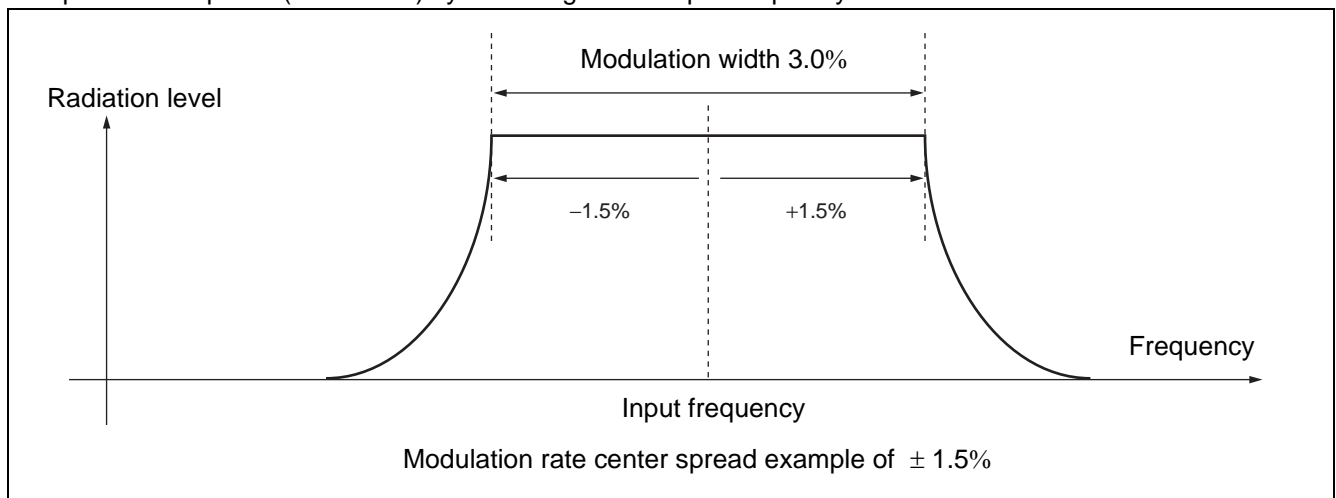

#### • Down spread

Spectrum is spread (modulated) below the input frequency.

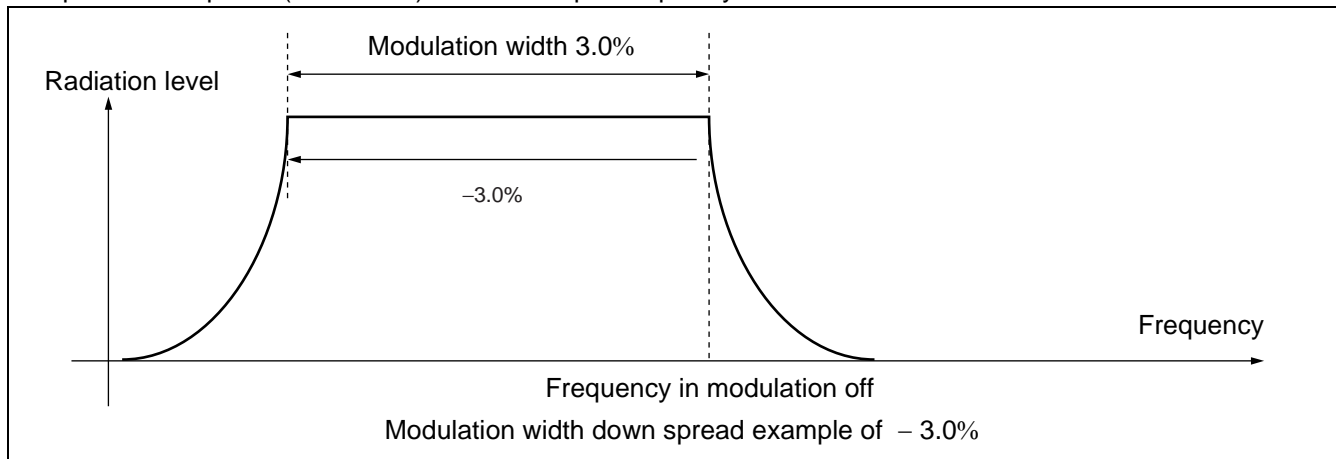

## ■ ABSOLUTE MAXIMUM RATINGS

Parameter	Symbol	Rating		Unit
		Min	Max	
Power supply voltage*	$V_{DD}$	- 0.5	+ 4.0	V
Input voltage*	$V_i$	$V_{SS} - 0.5$	$V_{DD} + 0.5$	V
Output voltage*	$V_o$	$V_{SS} - 0.5$	$V_{DD} + 0.5$	V
Storage temperature	$T_{ST}$	- 55	+ 125	°C
Operation junction temperature	$T_J$	- 40	+ 125	°C
Output current	$I_o$	- 14	+ 14	mA
Overshoot	$V_{IOVER}$	—	$V_{DD} + 1.0$ ( $t_{OVER} \leq 50$ ns)	V
Undershoot	$V_{IUNDER}$	$V_{SS} - 1.0$ ( $t_{UNDER} \leq 50$ ns)	—	V

\* : The parameter is based on  $V_{SS} = 0.0$  V.

**WARNING:** Semiconductor devices can be permanently damaged by application of stress (voltage, current, temperature, etc.) in excess of absolute maximum ratings. Do not exceed these ratings.

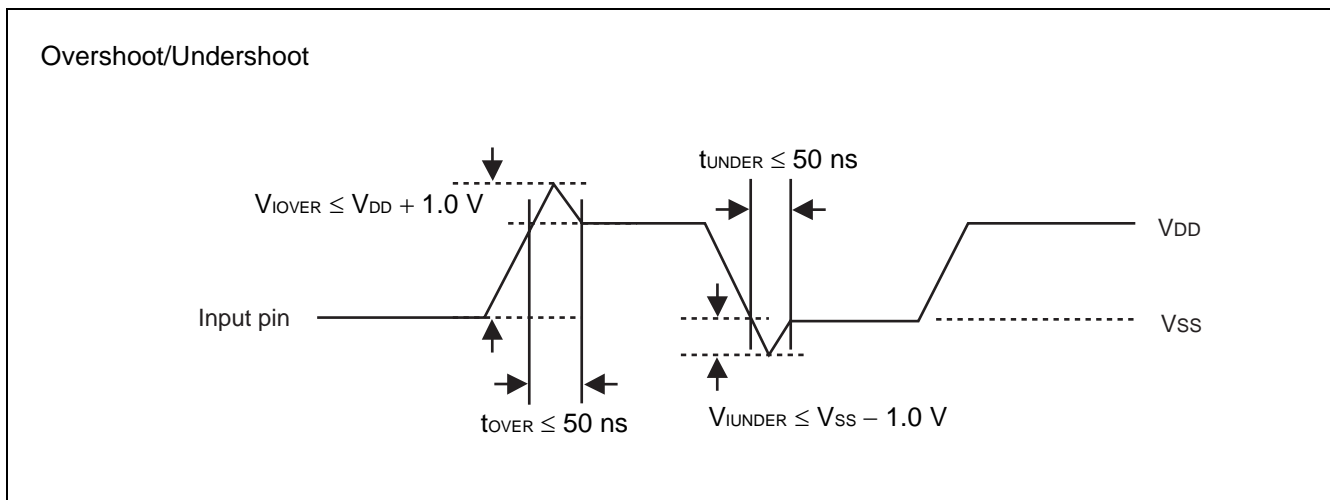

## RECOMMENDED OPERATING CONDITIONS

( $V_{SS} = 0.0\text{ V}$ )

Parameter	Symbol	Pin	Conditions	Value			Unit
				Min	Typ	Max	
Power supply voltage	$V_{DD}$	$V_{DD}$	—	3.0	3.3	3.6	V
“H” level input voltage	$V_{IH}$	XIN, SEL0, SEL1	—	$V_{DD} \times 0.80$	—	$V_{DD} + 0.3$	V
“L” level input voltage	$V_{IL}$		—	$V_{SS}$	—	$V_{DD} \times 0.20$	V
Input clock duty cycle	$t_{DCI}$	XIN	16.6 MHz to 80 MHz	40	50	60	%
Operating temperature	$T_a$	—	—	- 40	—	+ 85	°C

**WARNING:** The recommended operating conditions are required in order to ensure the normal operation of the semiconductor device. All of the device’s electrical characteristics are warranted when the device is operated within these ranges.

Always use semiconductor devices within their recommended operating condition ranges. Operation outside these ranges may adversely affect reliability and could result in device failure.

No warranty is made with respect to uses, operating conditions, or combinations not represented on the data sheet. Users considering application outside the listed conditions are advised to contact their representatives beforehand.

Input clock duty cycle ( $t_{DCI} = t_b/t_a$ )

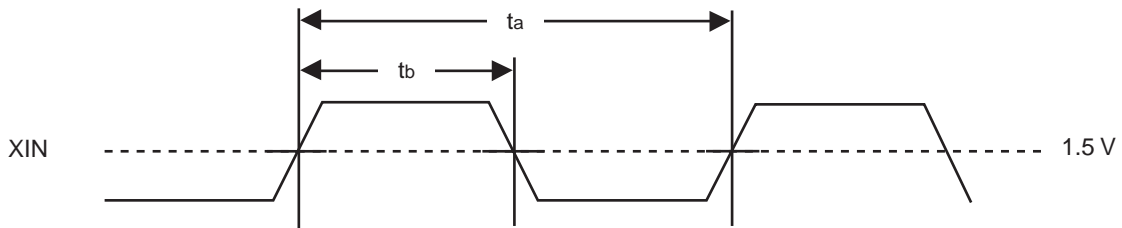



## ■ ELECTRICAL CHARACTERISTICS

- DC Characteristics

( $T_a = -40\text{ }^\circ\text{C}$  to  $+85\text{ }^\circ\text{C}$ ,  $V_{DD} = 3.3\text{ V} \pm 0.3\text{ V}$ ,  $V_{SS} = 0.0\text{ V}$ )

Parameter	Symbol	Pin	Conditions	Value			Unit
				Min	Typ	Max	
Power supply current	$I_{CC}$	$V_{DD}$	no load capacitance at 24 MHz output	—	5.0	7.0	mA
Output voltage	$V_{OH}$	CKOUT, REFOUT	“H” level output $I_{OH} = -3\text{ mA}$	$V_{DD} - 0.5$	—	$V_{DD}$	V
	$V_{OL}$		“L” level output $I_{OL} = 3\text{ mA}$	$V_{SS}$	—	0.4	V
Output impedance	$Z_o$	CKOUT, REFOUT	16.6 MHz to 80 MHz	—	70	—	$\Omega$
Input capacitance	$C_{IN}$	XIN, SEL0, SEL1	$T_a = +25\text{ }^\circ\text{C}$ , $V_{DD} = V_I = 0.0\text{ V}$ , $f = 1\text{ MHz}$	—	—	16	pF

# MB88154A

• AC Characteristics

( $T_a = -40\text{ }^{\circ}\text{C}$  to  $+85\text{ }^{\circ}\text{C}$ ,  $V_{DD} = 3.3\text{ V} \pm 0.3\text{ V}$ ,  $V_{SS} = 0.0\text{ V}$ )

Parameter	Symbol	Pin	Conditions	Value			Unit
				Min	Typ	Max	
Oscillation frequency	$f_x$	XIN, XOUT	Fundamental oscillation	16.6	—	40	MHz
			3rd over-tone oscillation	40	—	48	
Input frequency	$f_{in}$	XIN	MB88154A-103/113	16.6	—	40	MHz
			MB88154A-102/112	33	—	67	
			MB88154A-101/111	50	—	80	
Output frequency	$f_{out}$	CKOUT, REFOUT	MB88154A-103/113	16.6	—	40	MHz
			MB88154A-102/112	33	—	67	
			MB88154A-101/111	50	—	80	
Output slew rate	SR	CKOUT, REFOUT	0.4 V to 2.4 V load capacitance 15 pF	0.3	—	2.0	V/ns
Output clock duty cycle	$t_{DCC}$	CKOUT	1.5 V	40	—	60	%
	$t_{DCR}$	REFOUT	1.5 V	$t_{DCI} - 10^*$	—	$t_{DCI} + 10^*$	%
Modulation frequency (Number of input clocks per modulation)	$f_{MOD}$ ( $n_{MOD}$ )	CKOUT	MB88154A-103/113	$f_{in}/2640$ (2640)	$f_{in}/2280$ (2280)	$f_{in}/1920$ (1920)	kHz (clks)
			MB88154A-102/112	$f_{in}/4400$ (4400)	$f_{in}/3800$ (3800)	$f_{in}/3200$ (3200)	
			MB88154A-101/111	$f_{in}/5280$ (5280)	$f_{in}/4560$ (4560)	$f_{in}/3840$ (3840)	
Lock-Up time	$t_{LK}$	CKOUT	—	—	2	5	ms
Cycle-cycle jitter	$t_{JC}$	CKOUT	No load capacitance, $T_a = +25\text{ }^{\circ}\text{C}$ , $V_{DD} = 3.3\text{ V}$	—	—	100	ps-rms

\* : Duty of the REFOUT output is guaranteed only for the following A and B because it depends on  $t_{DCI}$  of input clock duty.

A. Resonator : When resonator is connected with XIN and XOUT and oscillates normally.

B. External clock input : The input level is Full - swing ( $V_{SS} - V_{DD}$ ).

## <Definition of modulation frequency and number of input clocks per modulation>

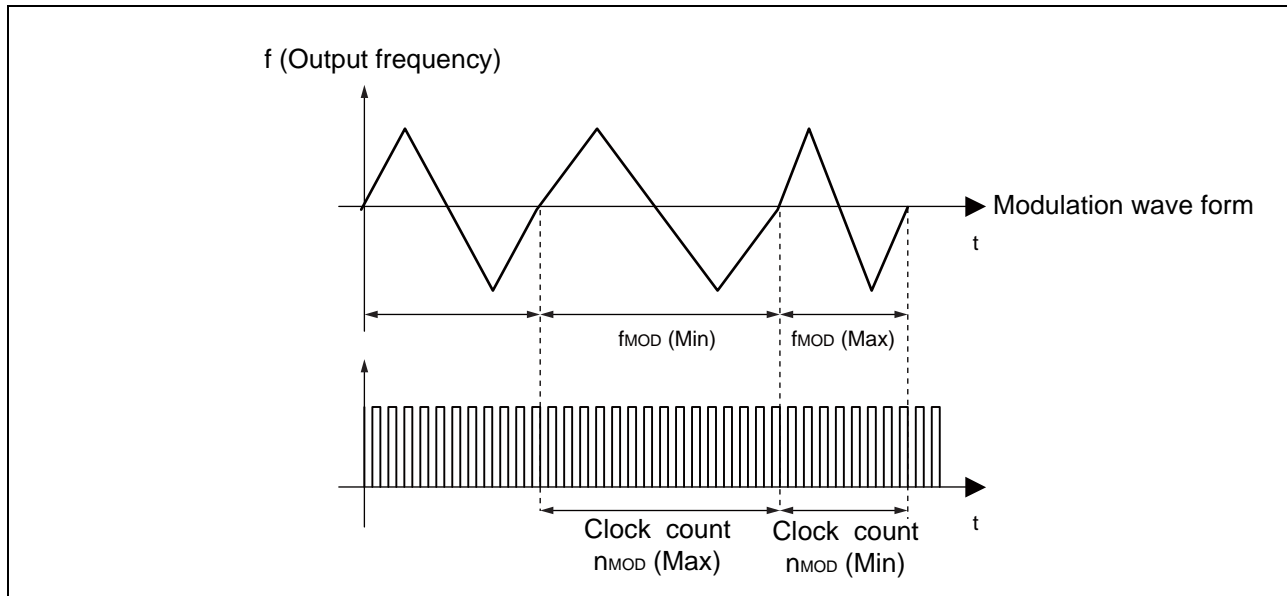

MB88154A contains the modulation period to realize the efficient EMI reduction. The modulation period  $f_{MOD}$  depends on the input frequency and changes between  $f_{MOD} (Min)$  and  $f_{MOD} (Max)$ . Furthermore, the average value of  $f_{MOD}$  equals the typical value of the electrical characteristics.

# MB88154A

## ■ OUTPUT CLOCK DUTY CYCLE ( $t_{DCC}$ , $t_{DCR} = t_b/t_a$ )

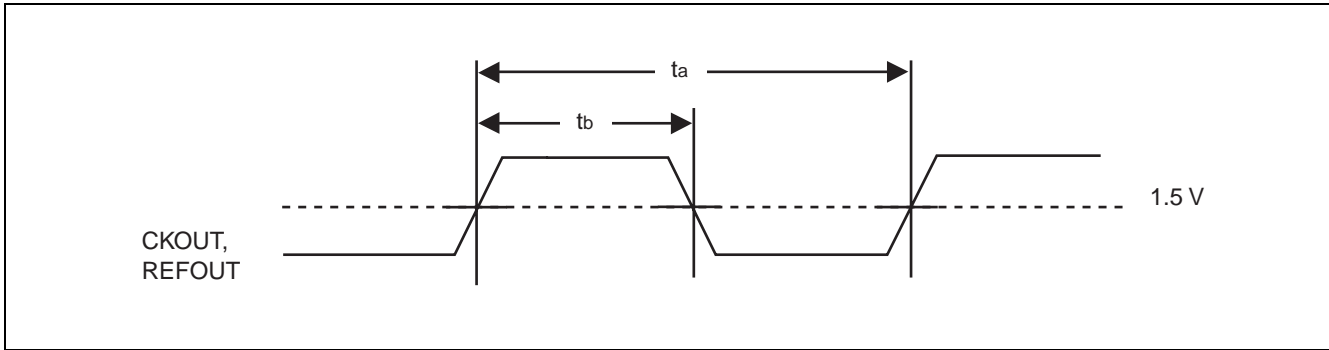

## ■ INPUT FREQUENCY ( $f_{in} = 1/t_{in}$ )

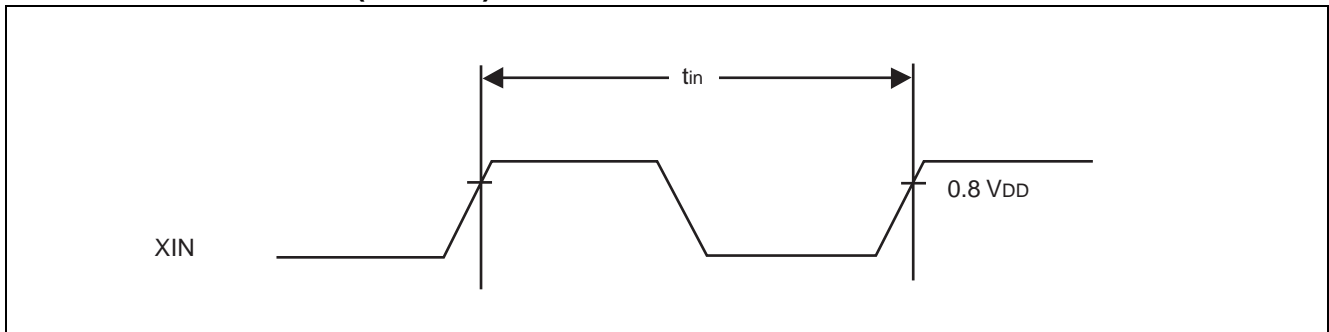

## ■ OUTPUT SLEW RATE (SR)

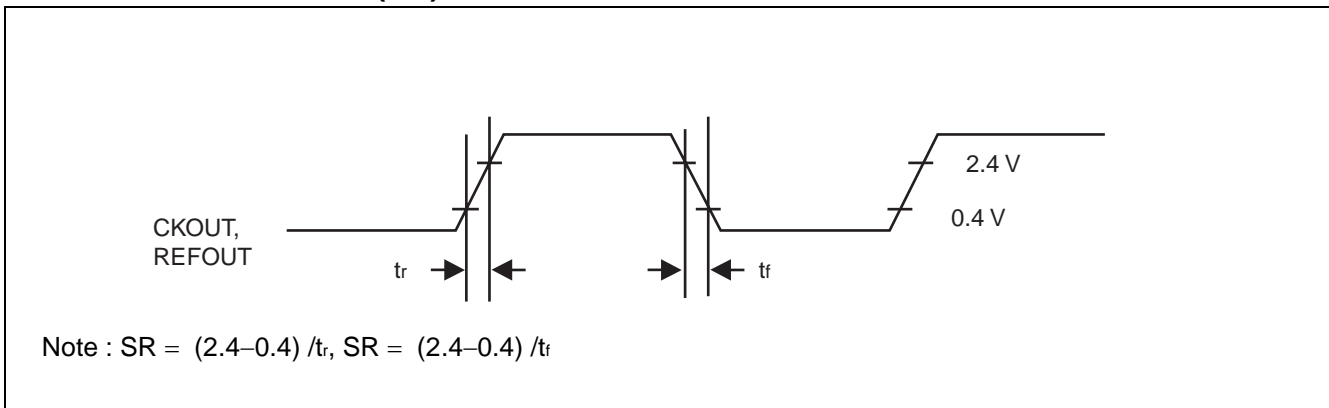

## ■ CYCLE-CYCLE JITTER ( $t_{JC} = |t_n - t_{n+1}|$ )

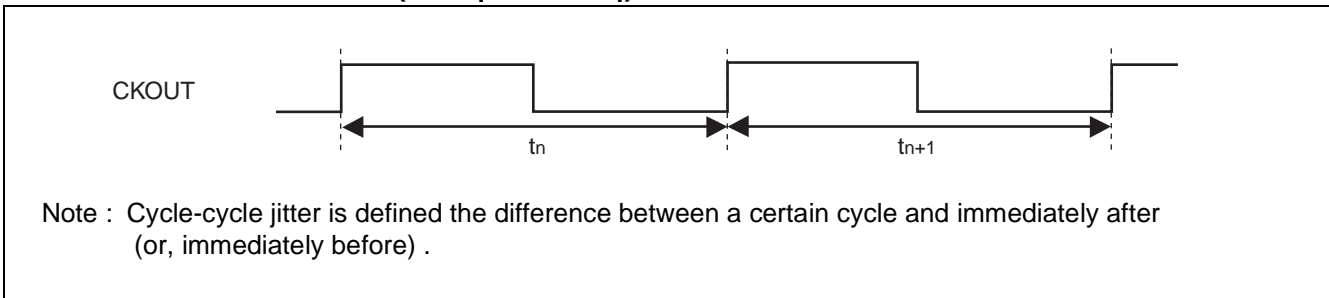

## MODULATION WAVEFORM

- $\pm 1.5\%$  modulation rate, Example of center spread

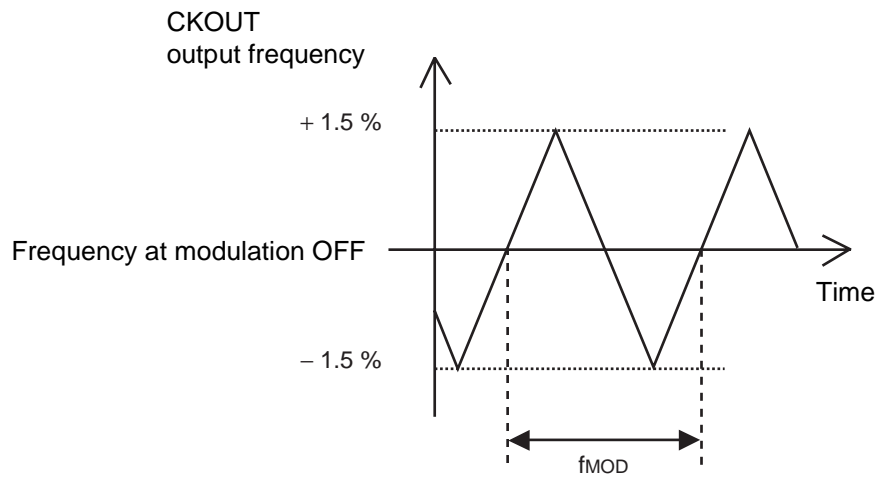

- $-1.0\%$  modulation rate, Example of down spread

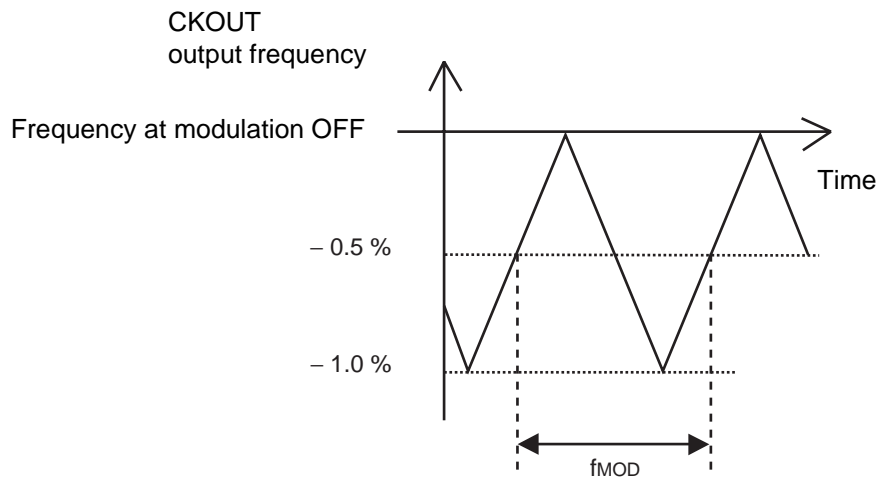

## ■ LOCK-UP TIME

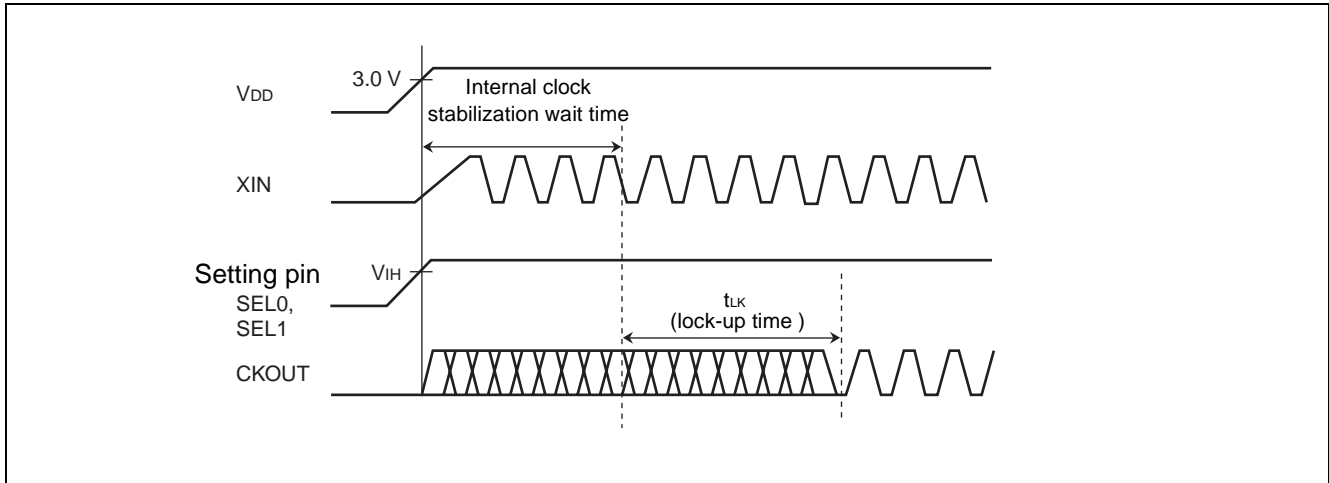

If the setting pin is fixed at the "H" or "L" level, the maximum time after the power is turned on until the set clock signal is output from CKOUT pin is (the stabilization wait time of input clock to XIN pin) + (the lock-up time " $t_{LK}$ "). For the input clock stabilization time, check the characteristics of the resonator or oscillator used.

Note : When the pin setting is changed, the CKOUT pin output clock stabilization time is required. Until the output clock signal becomes stable, the output frequency, output clock duty cycle, modulation period, and cycle-cycle jitter cannot be guaranteed. It is therefore advisable to perform processing such as cancelling a reset of the device at the succeeding stage after the lock-up time.

## ■ OSCILLATION CIRCUIT

The left side of figures below shows the connection example about general resonator. The oscillation circuit has the built-in feedback resistance ( $1\text{ M}\Omega$ ). The value of capacity ( $C_1$  and  $C_2$ ) is required adjusting to the most suitable value of an individual resonator.

The right side of figures below shows the example of connecting for the 3rd over-tone resonator. The value of capacity ( $C_1$ ,  $C_2$  and  $C_3$ ) and inductance ( $L_1$ ) is needed adjusting to the most suitable value of an individual resonator. The most suitable value is different by individual resonator. Please refer to the resonator manufacturer which use for the most suitable value. When an external clock is used (the resonator is not used), input the clock to XIN pin and do not connect anything with XOUT.

- When using a resonator

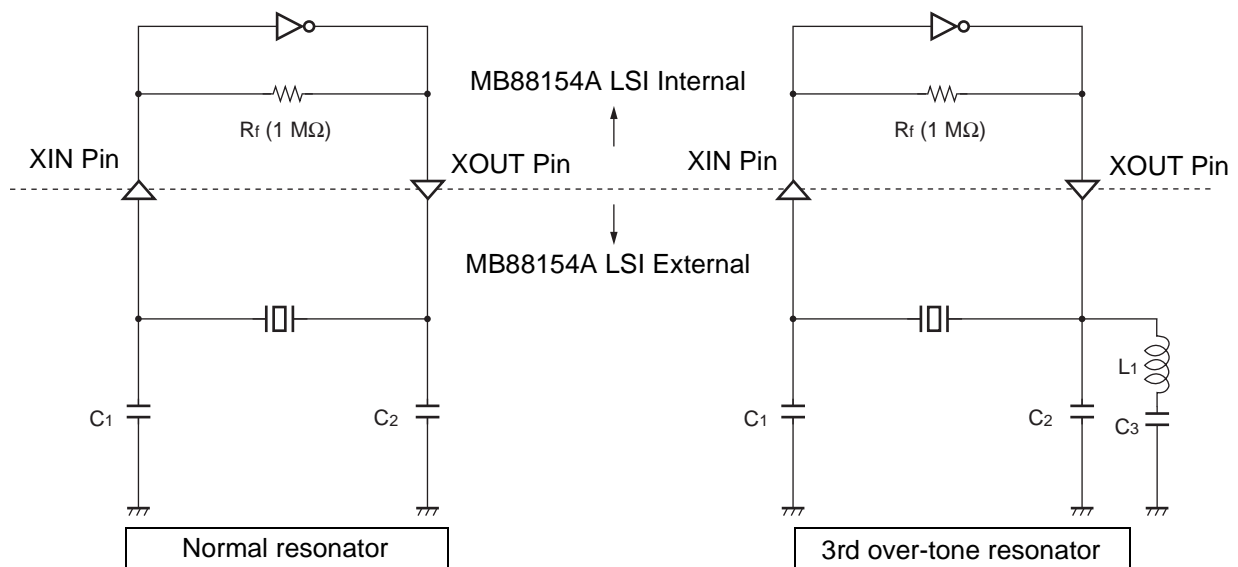

- When using an external clock

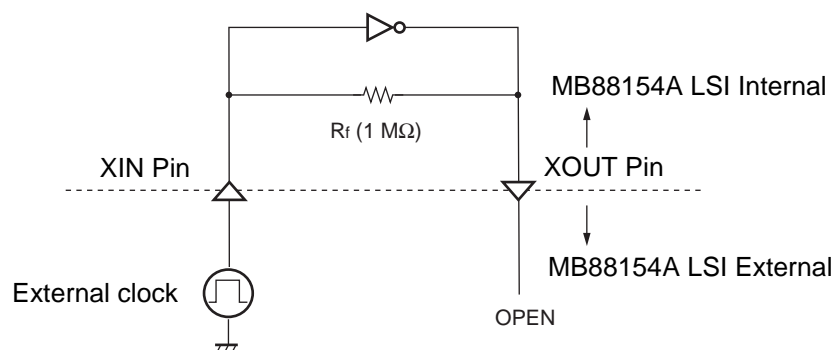

Note : Note that a jitter characteristic of an input clock may cause an affect a cycle-cycle jitter characteristic.

# MB88154A

## ■ INTERCONNECTION CIRCUIT EXAMPLE

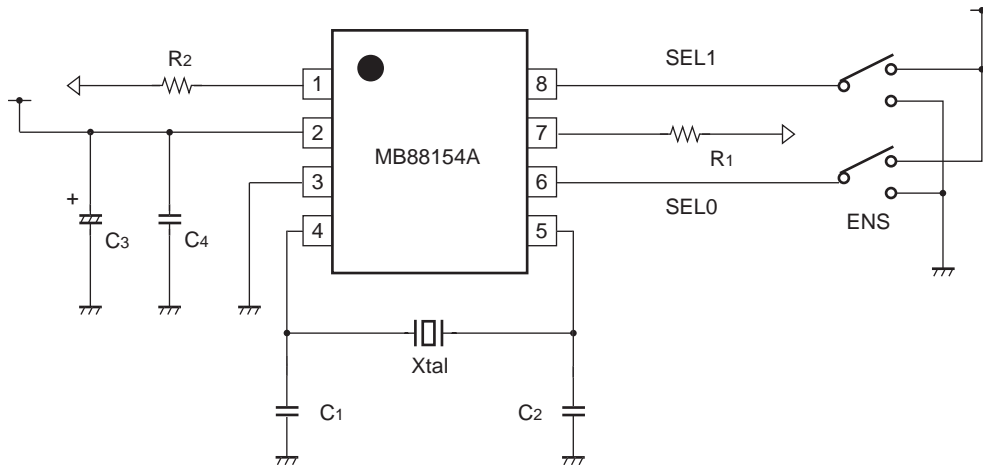

- C<sub>1</sub>, C<sub>2</sub> : Oscillation stabilization capacitance (refer to “■ OSCILLATION CIRCUIT”.)  
C<sub>3</sub> : Capacitor of 10  $\mu$ F or higher  
C<sub>4</sub> : Capacitor about 0.01  $\mu$ F (connect a capacitor of good high frequency property (ex. laminated ceramic capacitor) to close to this device.)  
R<sub>1</sub>, R<sub>2</sub> : Impedance matching resistor for board pattern



## ■ EXAMPLE CHARACTERISTICS

The condition of the examples of the characteristic is shown as follows: Input frequency = 20 MHz (Output frequency = 20 MHz : Using MB88154A-113), Power - supply voltage = 3.3 V, None load capacity.

Modulation rate =  $\pm 1.5\%$  (center spread)

Spectrum analyzer HP4396B is connected with CKOUT. The result of the measurement with RBW = 1 kHz (ATT use for -6dB).

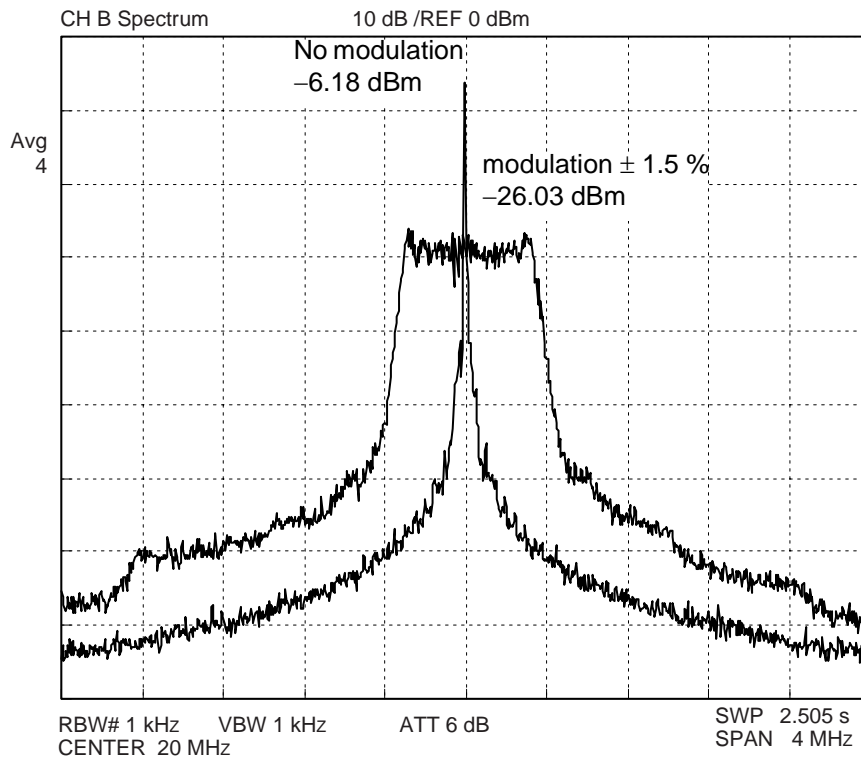

# MB88154A

## ■ ORDERING INFORMATION

Part number	Input/Output frequency	Modulation type	Package	Remarks
MB88154APNF-G-101-JNE1	50 MHz to 80 MHz	Down	8-pin plastic SOP (FPT-8P-M02)	
MB88154APNF-G-102-JNE1	33 MHz to 67 MHz	Down		
MB88154APNF-G-103-JNE1	16.6 MHz to 40 MHz	Down		
MB88154APNF-G-111-JNE1	50 MHz to 80 MHz	Center		
MB88154APNF-G-112-JNE1	33 MHz to 67 MHz	Center		
MB88154APNF-G-113-JNE1	16.6 MHz to 40 MHz	Center		
MB88154APNF-G-101-JNEFE1	50 MHz to 80 MHz	Down	8-pin plastic SOP (FPT-8P-M02)	Emboss taping (EF type)
MB88154APNF-G-102-JNEFE1	33 MHz to 67 MHz	Down		
MB88154APNF-G-103-JNEFE1	16.6 MHz to 40 MHz	Down		
MB88154APNF-G-111-JNEFE1	50 MHz to 80 MHz	Center		
MB88154APNF-G-112-JNEFE1	33 MHz to 67 MHz	Center		
MB88154APNF-G-113-JNEFE1	16.6 MHz to 40 MHz	Center		
MB88154APNF-G-101-JNERE1	50 MHz to 80 MHz	Down	8-pin plastic SOP (FPT-8P-M02)	Emboss taping (ER type)
MB88154APNF-G-102-JNERE1	33 MHz to 67 MHz	Down		
MB88154APNF-G-103-JNERE1	16.6 MHz to 40 MHz	Down		
MB88154APNF-G-111-JNERE1	50 MHz to 80 MHz	Center		
MB88154APNF-G-112-JNERE1	33 MHz to 67 MHz	Center		
MB88154APNF-G-113-JNERE1	16.6 MHz to 40 MHz	Center		

## ■ PACKAGE DIMENSION

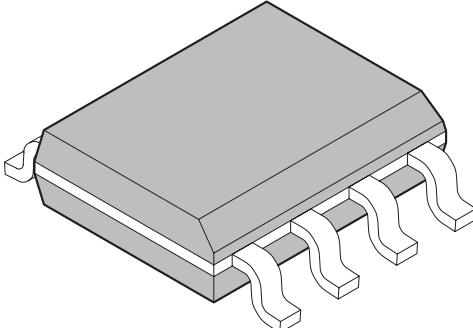
<p style="text-align: center;">8-pin plastic SOP</p>  <p style="text-align: center;">(FPT-8P-M02)</p>	Lead pitch	1.27 mm
	Package width × package length	3.9 × 5.05 mm
	Lead shape	Gullwing
	Sealing method	Plastic mold
	Mounting height	1.75 mm MAX
	Weight	0.06 g

8-pin plastic SOP  
(FPT-8P-M02)

Note 1) \*1 : These dimensions include resin protrusion.  
 Note 2) \*2 : These dimensions do not include resin protrusion.  
 Note 3) Pins width and pins thickness include plating thickness.  
 Note 4) Pins width do not include tie bar cutting remainder.

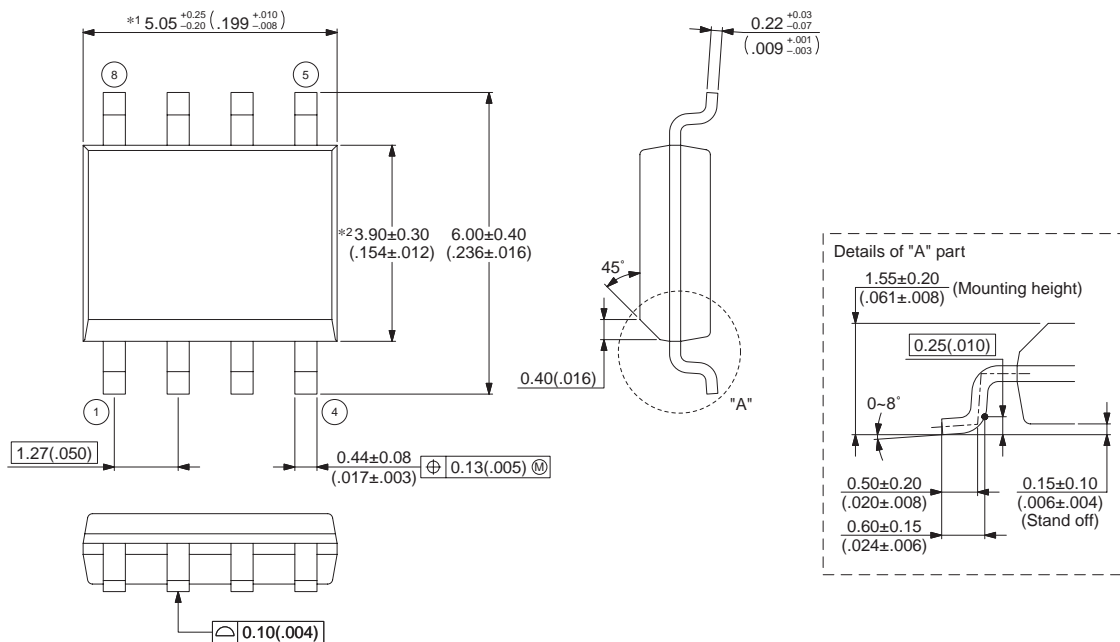

© 2002 FUJITSU LIMITED F08004S-c-4-7

Dimensions in mm (inches).  
 Note: The values in parentheses are reference values.

Please confirm the latest Package dimension by following URL.  
<http://edevice.fujitsu.com/package/en-search/>

# FUJITSU MICROELECTRONICS LIMITED

Shinjuku Dai-Ichi Seimei Bldg. 7-1, Nishishinjuku 2-chome, Shinjuku-ku,  
Tokyo 163-0722, Japan Tel: +81-3-5322-3347 Fax: +81-3-5322-3387  
<http://jp.fujitsu.com/fml/en/>

*For further information please contact:*

## **North and South America**

FUJITSU MICROELECTRONICS AMERICA, INC.  
1250 E. Arques Avenue, M/S 333  
Sunnyvale, CA 94085-5401, U.S.A.  
Tel: +1-408-737-5600 Fax: +1-408-737-5999  
<http://www.fma.fujitsu.com/>

## **Europe**

FUJITSU MICROELECTRONICS EUROPE GmbH  
Pittlerstrasse 47, 63225 Langen,  
Germany  
Tel: +49-6103-690-0 Fax: +49-6103-690-122  
<http://emea.fujitsu.com/microelectronics/>

## **Korea**

FUJITSU MICROELECTRONICS KOREA LTD.  
206 KOSMO TOWER, 1002 Daechi-Dong,  
Kangnam-Gu, Seoul 135-280  
Korea  
Tel: +82-2-3484-7100 Fax: +82-2-3484-7111  
<http://www.fmk.fujitsu.com/>

## **Asia Pacific**

FUJITSU MICROELECTRONICS ASIA PTE LTD.  
151 Lorong Chuan, #05-08 New Tech Park,  
Singapore 556741  
Tel: +65-6281-0770 Fax: +65-6281-0220  
<http://www.fujitsu.com/sg/services/micro/semiconductor/>

FUJITSU MICROELECTRONICS SHANGHAI CO., LTD.  
Rm.3102, Bund Center, No.222 Yan An Road(E),  
Shanghai 200002, China  
Tel: +86-21-6335-1560 Fax: +86-21-6335-1605  
<http://cn.fujitsu.com/fmc/>

FUJITSU MICROELECTRONICS PACIFIC ASIA LTD.  
10/F., World Commerce Centre, 11 Canton Road  
Tsimshatsui, Kowloon  
Hong Kong  
Tel: +852-2377-0226 Fax: +852-2376-3269  
<http://cn.fujitsu.com/fmc/tw>

All Rights Reserved.

The contents of this document are subject to change without notice.

Customers are advised to consult with sales representatives before ordering.

The information, such as descriptions of function and application circuit examples, in this document are presented solely for the purpose of reference to show examples of operations and uses of FUJITSU MICROELECTRONICS device; FUJITSU MICROELECTRONICS does not warrant proper operation of the device with respect to use based on such information. When you develop equipment incorporating the device based on such information, you must assume any responsibility arising out of such use of the information.

FUJITSU MICROELECTRONICS assumes no liability for any damages whatsoever arising out of the use of the information.

Any information in this document, including descriptions of function and schematic diagrams, shall not be construed as license of the use or exercise of any intellectual property right, such as patent right or copyright, or any other right of FUJITSU MICROELECTRONICS or any third party or does FUJITSU MICROELECTRONICS warrant non-infringement of any third-party's intellectual property right or other right by using such information. FUJITSU MICROELECTRONICS assumes no liability for any infringement of the intellectual property rights or other rights of third parties which would result from the use of information contained herein.

The products described in this document are designed, developed and manufactured as contemplated for general use, including without limitation, ordinary industrial use, general office use, personal use, and household use, but are not designed, developed and manufactured as contemplated (1) for use accompanying fatal risks or dangers that, unless extremely high safety is secured, could have a serious effect to the public, and could lead directly to death, personal injury, severe physical damage or other loss (i.e., nuclear reaction control in nuclear facility, aircraft flight control, air traffic control, mass transport control, medical life support system, missile launch control in weapon system), or (2) for use requiring extremely high reliability (i.e., submersible repeater and artificial satellite).

Please note that FUJITSU MICROELECTRONICS will not be liable against you and/or any third party for any claims or damages arising in connection with above-mentioned uses of the products.

Any semiconductor devices have an inherent chance of failure. You must protect against injury, damage or loss from such failures by incorporating safety design measures into your facility and equipment such as redundancy, fire protection, and prevention of over-current levels and other abnormal operating conditions.

Exportation/release of any products described in this document may require necessary procedures in accordance with the regulations of the Foreign Exchange and Foreign Trade Control Law of Japan and/or US export control laws.

The company names and brand names herein are the trademarks or registered trademarks of their respective owners.