

GENERAL DESCRIPTION



The ICS87332I-01 is a high performance ÷2 Differential-to-2.5V/3.3V ECL/LVPECL Clock Generator. The CLK, nCLK pair can accept most standard differential input levels. The ICS87332I-01 is characterized to operate from either a 2.5V or a 3.3V power supply. Guaranteed output and part-to-part skew characteristics make the ICS87332I-01 ideal for those clock distribution applications demanding well defined performance and repeatability.

FEATURES

- One ÷2 differential 2.5V/3.3V LVPECL / ECL output
- One CLK, nCLK input pair
- CLK, nCLK pair can accept the following differential input levels: LVDS, LVPECL, LVHSTL, SSTL, HCSL
- Maximum output frequency: 500MHz
- Maximum input frequency: 1GHz
- Translates any single ended input signal to 3.3V LVPECL levels with resistor bias on nCLK input
- Part-to-part skew: 400ps (maximum)
- Propagation delay: 1.6ns (maximum)
- LVPECL mode operating voltage supply range: $V_{CC} = 2.375V$ to $3.8V$, $V_{EE} = 0V$
- ECL mode operating voltage supply range: $V_{CC} = 0V$, $V_{EE} = -2.375V$ to $-3.8V$
- $-40^{\circ}C$ to $85^{\circ}C$ ambient operating temperature
- Available in both standard (RoHS 5) and lead-free (RoHS 6) packages

BLOCK DIAGRAM

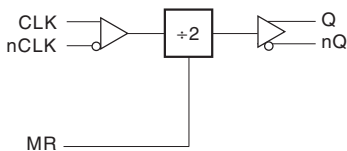

PIN ASSIGNMENT

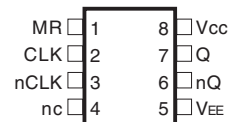

ICS87332I-01

8-Lead SOIC

3.90mm x 4.90mm x 1.37mm package body

M Package

Top View

TABLE 1. PIN DESCRIPTIONS

Number	Name	Type		Description
1	MR	Input	Pulldown	Master reset. When LOW, outputs are enabled. When HIGH, divider is reset forcing Q output LOW and nQ output HIGH. LVCMOS / LVTTTL interface level.
2	CLK	Input	Pulldown	Non-inverting differential clock input.
3	nCLK	Input	Pullup	Inverting differential clock input.
4	nc	Unused		No connect.
5	V _{EE}	Power		Negative supply pin.
6, 7	Q, nQ	Output		Differential output pair. LVPECL interface levels.
8	V _{CC}	Power		Positive supply pin.

NOTE: *Pullup* and *Pulldown* refer to internal input resistors. See Table 2, Pin Characteristics, for typical values.

TABLE 2. PIN CHARACTERISTICS

Symbol	Parameter	Test Conditions	Minimum	Typical	Maximum	Units
C _{IN}	Input Capacitance			4		pF
R _{PULLUP}	Input Pullup Resistor			51		kΩ
R _{PULLDOWN}	Input Pulldown Resistor			51		kΩ

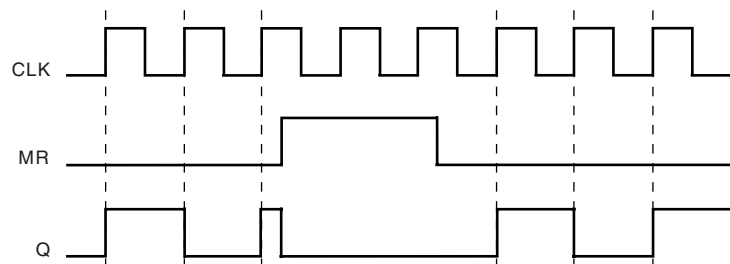
**FIGURE 1. TIMING DIAGRAM**

ABSOLUTE MAXIMUM RATINGS

Supply Voltage, V_{CC}	4.6V
Inputs, V_I	-0.5V to $V_{CC} + 0.5V$
Outputs, I_O	
Continuous Current	50mA
Surge Current	100mA
Package Thermal Impedance, θ_{JA}	112.7°C/W (0 lfpm)
Storage Temperature, T_{STG}	-65°C to 150°C

NOTE: Stresses beyond those listed under Absolute Maximum Ratings may cause permanent damage to the device. These ratings are stress specifications only. Functional operation of product at these conditions or any conditions beyond those listed in the *DC Characteristics* or *AC Characteristics* is not implied. Exposure to absolute maximum rating conditions for extended periods may affect product reliability.

TABLE 3A. POWER SUPPLY DC CHARACTERISTICS, $V_{CC} = 2.375V$ TO $3.8V$, $V_{EE} = 0$, $T_A = -40^\circ C$ TO $85^\circ C$

Symbol	Parameter	Test Conditions	Minimum	Typical	Maximum	Units
V_{CC}	Positive Supply Voltage		2.375	3.3	3.8	V
I_{EE}	Power Supply Current				30	mA

TABLE 3B. LVCMOS DC CHARACTERISTICS, $V_{CC} = 2.375V$ TO $3.8V$, $V_{EE} = 0$, $T_A = -40^\circ C$ TO $85^\circ C$

Symbol	Parameter	Test Conditions	Minimum	Typical	Maximum	Units
V_{IH}	Input High Voltage	MR	2		$V_{CC} + 0.3$	V
V_{IL}	Input Low Voltage	MR	-0.3		0.8	V
I_{IH}	Input High Current	MR			150	μA
I_{IL}	Input Low Current	MR				μA

TABLE 3C. DIFFERENTIAL DC CHARACTERISTICS, $V_{CC} = 2.375V$ TO $3.8V$, $V_{EE} = 0$, $T_A = -40^\circ C$ TO $85^\circ C$

Symbol	Parameter	Test Conditions	Minimum	Typical	Maximum	Units
I_{IH}	Input High Current	CLK	$V_{CC} = V_{IN} = 3.8V$		150	μA
		nCLK	$V_{CC} = V_{IN} = 3.8V$		5	μA
I_{IL}	Input Low Current	CLK	$V_{CC} = 3.8V, V_{IN} = 0V$	-5		μA
		nCLK	$V_{CC} = 3.8V, V_{IN} = 0V$	-150		μA
V_{PP}	Peak-to-Peak Input Voltage		0.15		1.3	V
V_{CMR}	Common Mode Input Voltage; NOTE 1, 2		$V_{EE} + 0.5$		$V_{CC} - 0.85$	V

NOTE 1: Common mode voltage is defined as V_{IH} .

NOTE 2: For single ended applications, the maximum input voltage for CLK, nCLK is $V_{CC} + 0.3V$.

TABLE 3D. LVPECL DC CHARACTERISTICS, $V_{CC} = 2.375V$ TO $3.8V$, $V_{EE} = 0$, $T_A = -40^{\circ}C$ TO $85^{\circ}C$

Symbol	Parameter	Test Conditions	Minimum	Typical	Maximum	Units
V_{OH}	Output High Voltage; NOTE 1		$V_{CC} - 1.4$		$V_{CC} - 0.9$	V
V_{OL}	Output Low Voltage; NOTE 1		$V_{CC} - 2.0$		$V_{CC} - 1.7$	V
V_{SWING}	Peak-to-Peak Output Voltage Swing		0.65		1.0	V

NOTE 1: Outputs terminated with 50Ω to $V_{CC} - 2V$.

TABLE 4. AC CHARACTERISTICS, $V_{CC} = 2.375V$ TO $3.8V$, $V_{EE} = 0$, $T_A = -40^{\circ}C$ TO $85^{\circ}C$

Symbol	Parameter	Test Conditions	Minimum	Typical	Maximum	Units
f_{MAX}	Input Frequency				1	GHz
t_{PD}	Propagation Delay; NOTE 1	$f \leq 1GHz$	1.1	1.4	1.6	ns
$t_{sk}(pp)$	Part-to-Part Skew; NOTE 2, 3				400	ps
t_R	Output Rise Time	20% to 80%	200		700	ps
t_F	Output Fall Time	20% to 80%	200		700	ps
odc	Output Duty Cycle		49		51	%

NOTE: Electrical parameters are guaranteed over the specified ambient operating temperature range, which is established when the device is mounted in a test socket with maintained transverse airflow greater than 500 lfm. The device will meet specifications after thermal equilibrium has been reached under these conditions.

NOTE: All parameters measured at 500MHz unless noted otherwise.

NOTE 1: Measured from the differential input crossing point to the differential output crossing point.

NOTE 2: Defined as skew between outputs on different devices operating at the same supply voltages and with equal load conditions. Using the same type of inputs on each device, the outputs are measured at the differential cross points.

NOTE 3: This parameter is defined in accordance with JEDEC Standard 65.

PARAMETER MEASUREMENT INFORMATION

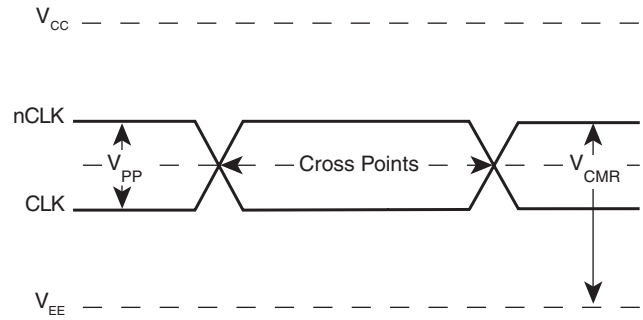
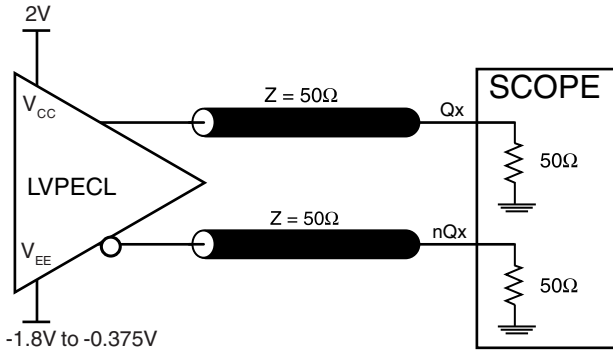

3.3V OUTPUT LOAD AC TEST CIRCUIT

DIFFERENTIAL INPUT LEVEL

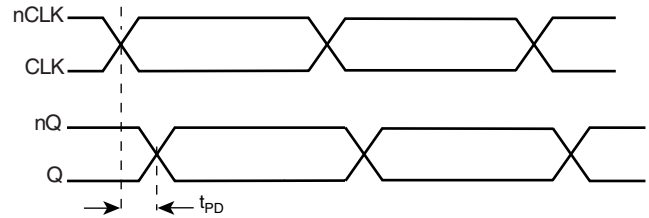
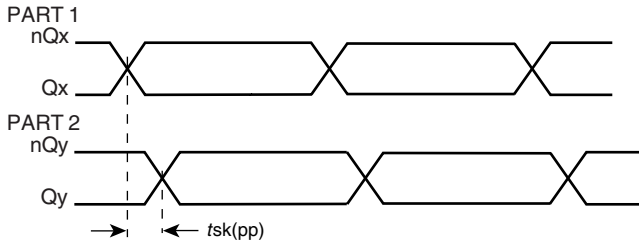

PART-TO-PART SKEW

PROPAGATION DELAY

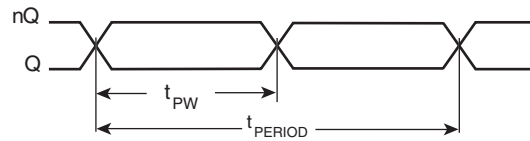
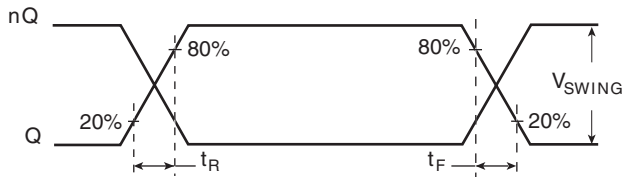

$$odc = \frac{t_{PW}}{t_{PERIOD}} \times 100\%$$

OUTPUT RISE/FALL TIME

OUTPUT DUTY CYCLE/PULSE WIDTH/PERIOD

APPLICATION INFORMATION

WIRING THE DIFFERENTIAL INPUT TO ACCEPT SINGLE ENDED LEVELS

Figure 2 shows how the differential input can be wired to accept single ended levels. The reference voltage $V_{REF} = V_{CC}/2$ is generated by the bias resistors R1, R2 and C1. This bias circuit should be located as close as possible to the input pin. The ratio of

R1 and R2 might need to be adjusted to position the V_{REF} in the center of the input voltage swing. For example, if the input clock swing is only 2.5V and $V_{CC} = 3.3V$, V_{REF} should be 1.25V and $R2/R1 = 0.609$.

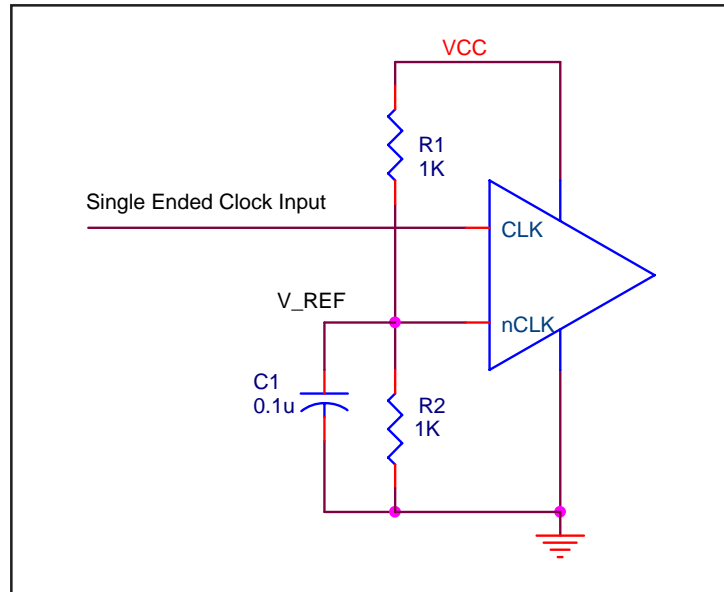

FIGURE 2. SINGLE ENDED SIGNAL DRIVING DIFFERENTIAL INPUT

TERMINATION FOR 3.3V LVPECL OUTPUTS

The clock layout topology shown below is a typical termination for LVPECL outputs. The two different layouts mentioned are recommended only as guidelines.

The differential outputs are low impedance follower outputs that generate ECL/LVPECL compatible outputs. Therefore, terminating resistors (DC current path to ground) or current sources must be used for functionality. These outputs are de-

signed to drive 50Ω transmission lines. Matched impedance techniques should be used to maximize operating frequency and minimize signal distortion. Figures 3A and 3B show two different layouts which are recommended only as guidelines. Other suitable clock layouts may exist and it would be recommended that the board designers simulate to guarantee compatibility across all printed circuit and clock component pro-

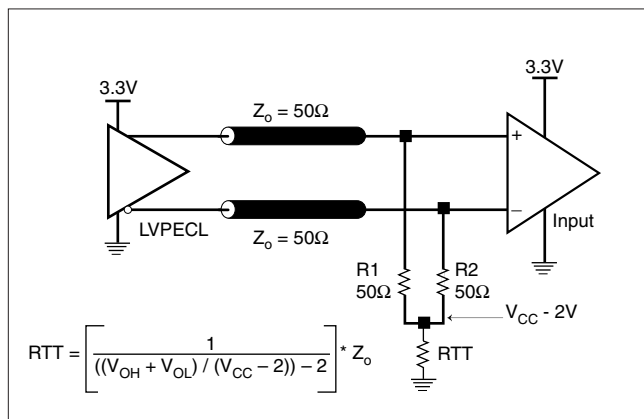

FIGURE 3A. LVPECL OUTPUT TERMINATION

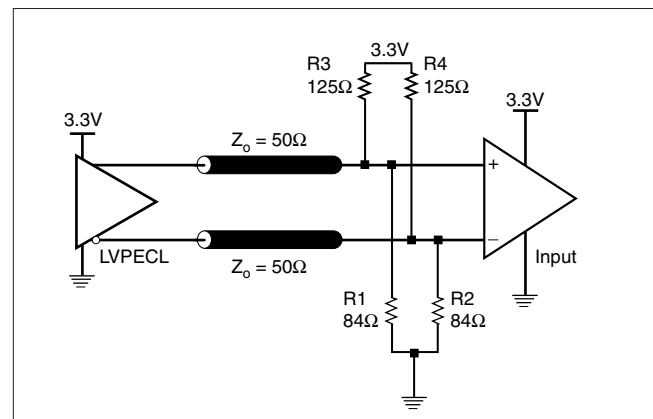

FIGURE 3B. LVPECL OUTPUT TERMINATION

TERMINATION FOR 2.5V LVPECL OUTPUTS

Figure 4A and Figure 4B show examples of termination for 2.5V LVPECL driver. These terminations are equivalent to terminating 50Ω to $V_{CC} - 2V$. For $V_{CC} = 2.5V$, the $V_{CC} - 2V$ is very close to ground

level. The R3 in Figure 4B can be eliminated and the termination is shown in Figure 4C.

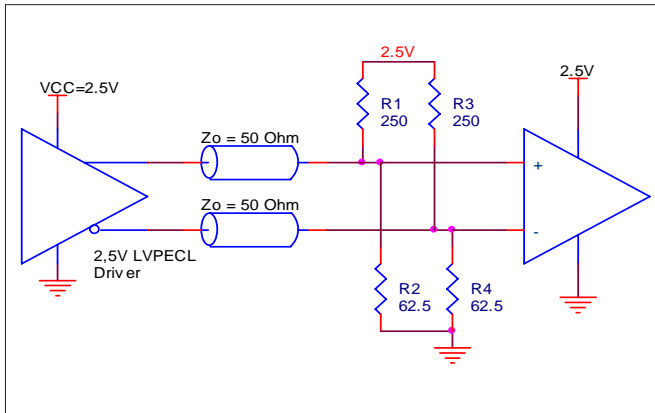

FIGURE 4A. 2.5V LVPECL DRIVER TERMINATION EXAMPLE

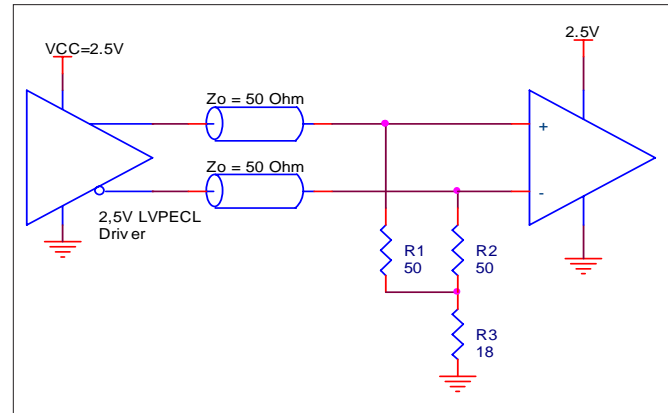

FIGURE 4B. 2.5V LVPECL DRIVER TERMINATION EXAMPLE

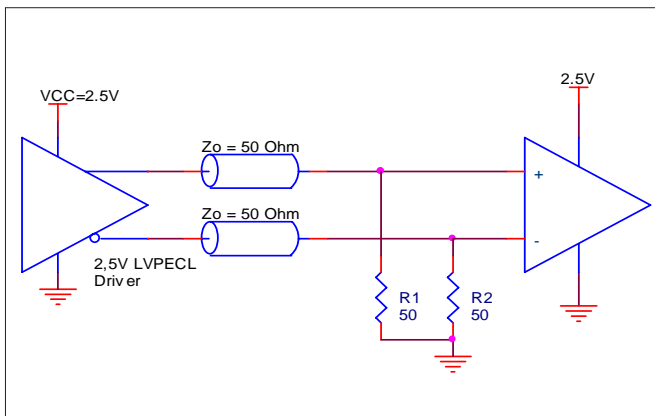

FIGURE 4C. 2.5V LVPECL TERMINATION EXAMPLE

DIFFERENTIAL CLOCK INPUT INTERFACE

The CLK /nCLK accepts LVDS, LVPECL, LVHSTL, SSTL, HCSL and other differential signals. Both V_{SWING} and V_{OH} must meet the V_{PP} and V_{CMR} input requirements. *Figures 5A to 5F* show interface examples for the CLK/nCLK input driven by the most common driver types. The input interfaces suggested here are examples only.

Please consult with the vendor of the driver component to confirm the driver termination requirements. For example in Figure 5A, the input termination applies for IDT open emitter LVHSTL drivers. If you are using an LVHSTL driver from another vendor, use their termination recommendation.

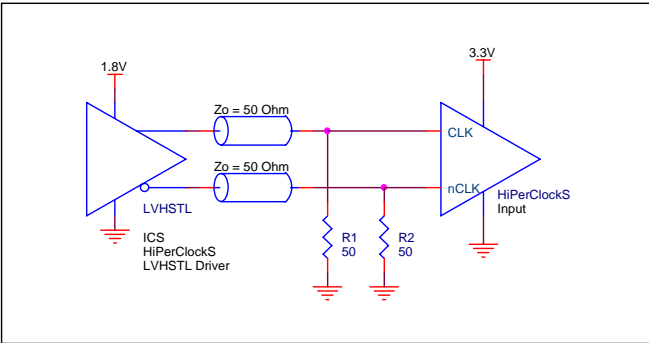

FIGURE 5A. CLK/nCLK INPUT DRIVEN BY AN IDT OPEN EMITTER LVHSTL DRIVER

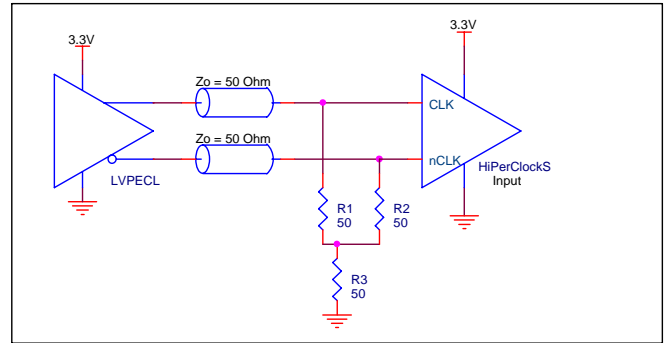

FIGURE 5B. CLK/nCLK INPUT DRIVEN BY A 3.3V LVPECL DRIVER

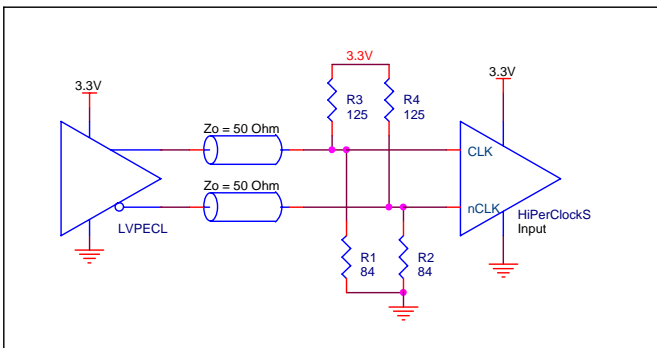

FIGURE 5C. CLK/nCLK INPUT DRIVEN BY A 3.3V LVPECL DRIVER

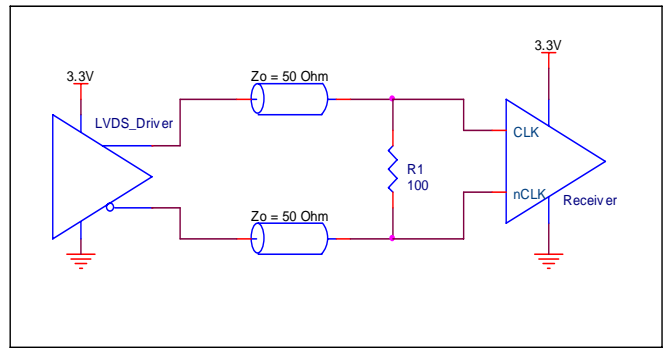

FIGURE 5D. CLK/nCLK INPUT DRIVEN BY A 3.3V LVDS DRIVER

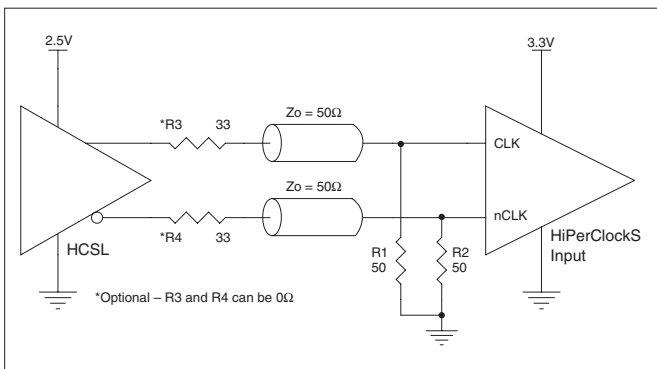

FIGURE 5E. CLK/nCLK INPUT DRIVEN BY A 3.3V HCSL DRIVER

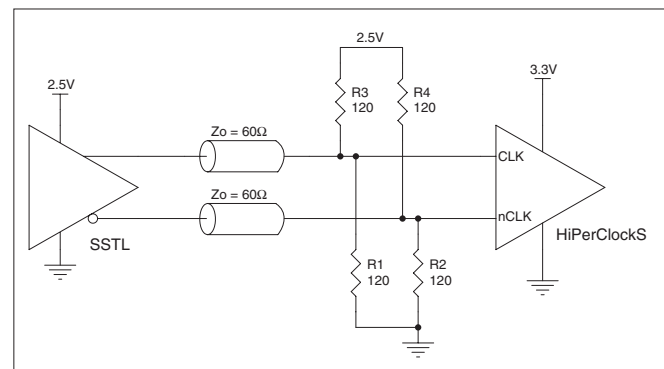

FIGURE 5F. CLK/nCLK INPUT DRIVEN BY A 2.5V SSTL DRIVER

POWER CONSIDERATIONS

This section provides information on power dissipation and junction temperature for the ICS87332I-01. Equations and example calculations are also provided.

1. Power Dissipation.

The total power dissipation for the ICS87332I-01 is the sum of the core power plus the power dissipated in the load(s). The following is the power dissipation for $V_{CC} = 3.8V$, which gives worst case results.

NOTE: Please refer to Section 3 for details on calculating power dissipated in the load.

- Power (core)_{MAX} = $V_{CC_MAX} * I_{EE_MAX} = 3.8V * 30mA = 114mW$
- Power (outputs)_{MAX} = **30mW/Loaded Output pair**

$$\text{Total Power}_{MAX} (3.8V, \text{ with all outputs switching}) = 114mW + 30mW = 144mW$$

2. Junction Temperature.

Junction temperature at the junction of the bond wire and bond pad directly affects the reliability of the device. The maximum recommended junction temperature for HiPerClockS™ devices is 125°C. Limiting the internal transistor junction temperature, T_j , to 125°C ensures that the bond wire and bond pad temperature remains below 125°C.

The equation for T_j is as follows: $T_j = \theta_{JA} * Pd_total + T_A$

T_j = Junction Temperature

θ_{JA} = Junction-to-Ambient Thermal Resistance

Pd_total = Total Device Power Dissipation (example calculation is in section 1 above)

T_A = Ambient Temperature

In order to calculate junction temperature, the appropriate junction-to-ambient thermal resistance θ_{JA} must be used. Assuming a moderate air flow of 200 linear feet per minute and a multi-layer board, the appropriate value is 103.3°C/W per Table 5 below.

Therefore, T_j for an ambient temperature of 85°C with all outputs switching is:

$$85^\circ C + 0.144W * 103.3^\circ C/W = 99.9^\circ C. \text{ This is well below the limit of } 125^\circ C$$

This calculation is only an example. T_j will obviously vary depending on the number of loaded outputs, supply voltage, air flow, and the type of board (multi-layer).

TABLE 5. THERMAL RESISTANCE θ_{JA} FOR 8-PIN SOIC, FORCED CONVECTION

	θ_{JA} by Velocity (Linear Feet per Minute)		
	0	200	500
Single-Layer PCB, JEDEC Standard Test Boards	153.3°C/W	128.5°C/W	115.5°C/W
Multi-Layer PCB, JEDEC Standard Test Boards	112.7°C/W	103.3°C/W	97.1°C/W

NOTE: Most modern PCB designs use multi-layered boards. The data in the second row pertains to most designs.

3. Calculations and Equations.

The purpose of this section is to calculate power dissipation on the LVPECL output pair.

LVPECL output driver circuit and termination are shown in *Figure 6*.

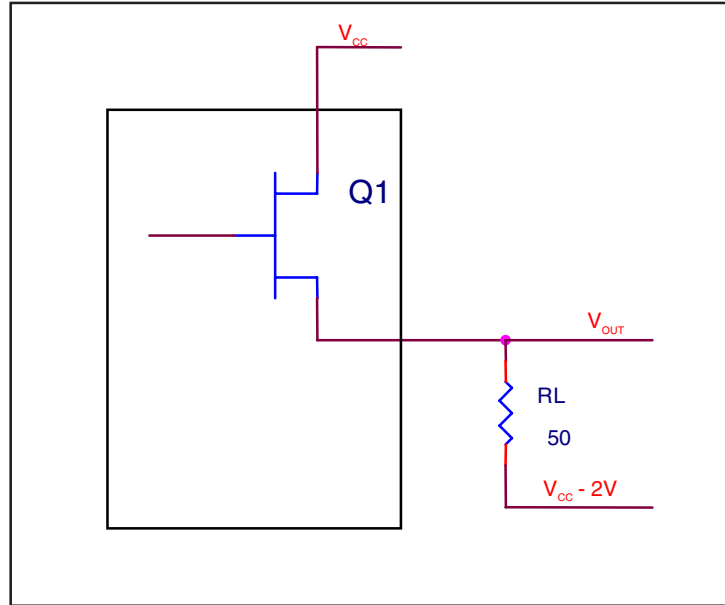

FIGURE 6. LVPECL DRIVER CIRCUIT AND TERMINATION

To calculate worst case power dissipation into the load, use the following equations which assume a 50Ω load, and a termination voltage of $V_{CC} - 2V$.

- For logic high, $V_{OUT} = V_{OH_MAX} = V_{CC_MAX} - 0.9V$
 $(V_{CC_MAX} - V_{OH_MAX}) = 0.9V$
- For logic low, $V_{OUT} = V_{OL_MAX} = V_{CC_MAX} - 1.7V$
 $(V_{CC_MAX} - V_{OL_MAX}) = 1.7V$

Pd_H is power dissipation when the output drives high.

Pd_L is the power dissipation when the output drives low.

$$Pd_H = [(V_{OH_MAX} - (V_{CC_MAX} - 2V))/R_L] * (V_{CC_MAX} - V_{OH_MAX}) = [(2V - (V_{CC_MAX} - V_{OH_MAX}))/R_L] * (V_{CC_MAX} - V_{OH_MAX}) = [(2V - 0.9V)/50\Omega] * 0.9V = 19.8mW$$

$$Pd_L = [(V_{OL_MAX} - (V_{CC_MAX} - 2V))/R_L] * (V_{CC_MAX} - V_{OL_MAX}) = [(2V - (V_{CC_MAX} - V_{OL_MAX}))/R_L] * (V_{CC_MAX} - V_{OL_MAX}) = [(2V - 1.7V)/50\Omega] * 1.7V = 10.2mW$$

Total Power Dissipation per output pair = $Pd_H + Pd_L = 30mW$

RELIABILITY INFORMATION

TABLE 6. θ_{JA} vs. AIR FLOW TABLE

θ_{JA} by Velocity (Linear Feet per Minute)			
	0	200	500
Single-Layer PCB, JEDEC Standard Test Boards	153.3°C/W	128.5°C/W	115.5°C/W
Multi-Layer PCB, JEDEC Standard Test Boards	112.7°C/W	103.3°C/W	97.1°C/W

NOTE: Most modern PCB designs use multi-layered boards. The data in the second row pertains to most designs.

TRANSISTOR COUNT

The transistor count for ICS87332I-01 is: 383

Compatible to part number MC100EP32

PACKAGE OUTLINE AND DIMENSIONS

PACKAGE OUTLINE - M SUFFIX

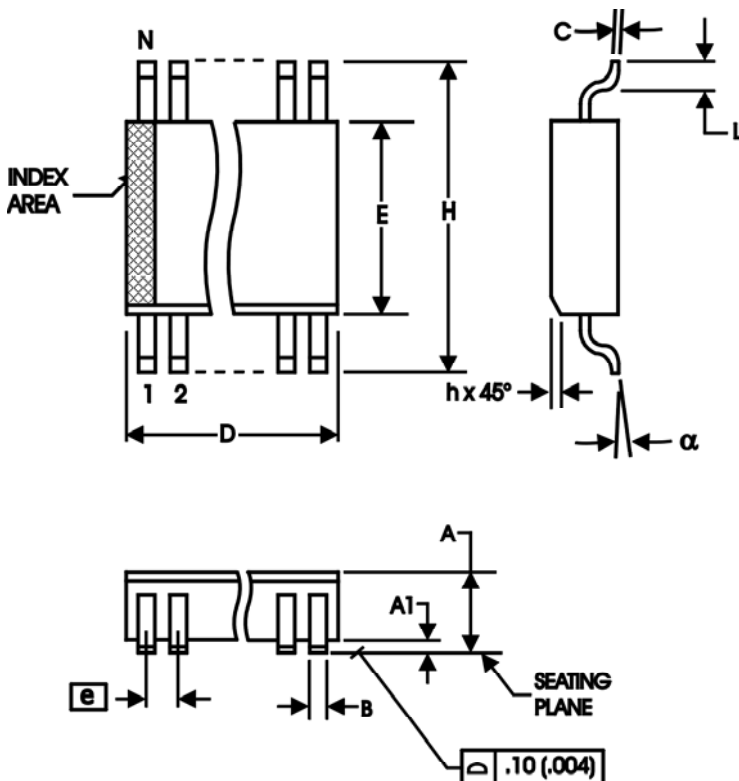

TABLE 7. PACKAGE DIMENSIONS

SYMBOL	Millimeters	
	MINIMUM	MAXIMUM
N	8	
A	1.35	1.75
A1	0.10	0.25
B	0.33	0.51
C	0.19	0.25
D	4.80	5.00
E	3.80	4.00
e	1.27 BASIC	
H	5.80	6.20
h	0.25	0.50
L	0.40	1.27
α	0°	8°

Reference Document: JEDEC Publication 95, MS-012

TABLE 8. ORDERING INFORMATION

Part/Order Number	Marking	Package	Shipping Package	Temperature
87332AMI-01	7332AI01	8 lead SOIC	tube	-40°C to 85°C
87332AMI-01T	7332AI01	8 lead SOIC	2500 tape & reel	-40°C to 85°C
87332AMI-01LF	332AI01L	8 lead "Lead-Free" SOIC	tube	-40°C to 85°C
87332AMI-01LFT	332AI01L	8 lead "Lead-Free" SOIC	2500 tape & reel	-40°C to 85°C

NOTE: Parts that are ordered with an "LF" suffix to the part number are the Pb-Free configuration and are RoHS compliant.

While the information presented herein has been checked for both accuracy and reliability, Integrated Device Technology, Incorporated (IDT) assumes no responsibility for either its use or for infringement of any patents or other rights of third parties, which would result from its use. No other circuits, patents, or licenses are implied. This product is intended for use in normal commercial and industrial applications. Any other applications such as those requiring high reliability or other extraordinary environmental requirements are not recommended without additional processing by IDT. IDT reserves the right to change any circuitry or specifications without notice. IDT does not authorize or warrant any IDT product for use in life support devices or critical medical instruments.

REVISION HISTORY SHEET				
Rev	Table	Page	Description of Change	Date
B	T2	1	Features Section - added Lead-Free bullet.	7/5/05
		2	Pin Characteristics Table - changed CIN from 4pF max. to 4pF typical.	
		6	Added "Wiring the Differential Input to Accept Single Ended Levels.	
		6	Added Termination for 3.3V LVPECL Output.	
		7	Added Termination for 2.5V LVPECL Output.	
T8	8	Added Differential Clock Input Interface.	Updated format of datasheet.	
	13	Ordering Information Table - corrected marking. Added Lead-Free part number and note.		
C	T3D	4	LVPECL DC Characteristics Table -corrected V_{OH} max. from $V_{CC} - 1.0V$ to $V_{CC} - 0.9V$; and V_{SWING} max. from 0.9V to 1.0V.	4/13/07
		9 - 10	Power Considerations - corrected power dissipation to reflect V_{OH} max in Table 3D.	
C	T4	4	Added thermal note to AC Characteristics table.	11/16/09
		6	Updated figures 3A & 3B, LVPECL Output Termination diagrams.	
		8	Updated Differential Clock Input Interface.	
		12	Ordering Information Table - add LF marking. Deleted "ICS" prefix from part/order number. Updated header/footer of datasheet.	



www.IDT.com

6024 Silver Creek Valley Road
San Jose, CA 95138

Sales

800-345-7015 (inside USA)
+408-284-8200 (outside USA)
Fax: 408-284-2775
www.IDT.com/go/contactIDT

Technical Support

netcom@idt.com
+480-763-2056

DISCLAIMER Integrated Device Technology, Inc. (IDT) and its subsidiaries reserve the right to modify the products and/or specifications described herein at any time and at IDT's sole discretion. All information in this document, including descriptions of product features and performance, is subject to change without notice. Performance specifications and the operating parameters of the described products are determined in the independent state and are not guaranteed to perform the same way when installed in customer products. The information contained herein is provided without representation or warranty of any kind, whether express or implied, including, but not limited to, the suitability of IDT's products for any particular purpose, an implied warranty of merchantability, or non-infringement of the intellectual property rights of others. This document is presented only as a guide and does not convey any license under intellectual property rights of IDT or any third parties.

IDT's products are not intended for use in life support systems or similar devices where the failure or malfunction of an IDT product can be reasonably expected to significantly affect the health or safety of users. Anyone using an IDT product in such a manner does so at their own risk, absent an express, written agreement by IDT.

Integrated Device Technology, IDT and the IDT logo are registered trademarks of IDT. Other trademarks and service marks used herein, including protected names, logos and designs, are the property of IDT or their respective third party owners.

Copyright 2009. All rights reserved.