

# MC12080

## 1.1 GHz Prescaler

### Description

The MC12080 is a single modulus divide by 10, 20, 40, 80 prescaler for low power frequency division of a 1.1 GHz high frequency input signal. Divide ratio control inputs SW1, SW2 and SW3 select the required divide ratio of  $\div 10$ ,  $\div 20$ ,  $\div 40$ , or  $\div 80$ .

An external load resistor is required to terminate the output. An 820  $\Omega$  resistor is recommended to achieve a 1.2 V<sub>pp</sub> output swing, when dividing a 1.1 GHz input signal by the minimum divide by ratio of 10, assuming a 8.0 pF load. Output current can be minimized dependent on conditions such as output frequency, capacitive load being driven, and output voltage swing required. Typical values for load resistors are included in the V<sub>out</sub> specification for various divide ratios at 1.1 GHz input frequency.

### Features

- 1.1 GHz Toggle Frequency
- Supply Voltage 4.5 to 5.5 V
- Low Power 3.7 mA Typical at V<sub>CC</sub> = 5.0 V
- Operating Temperature Range of -40 to 85°C
- Pb-Free Packages are Available

Table 1. FUNCTIONAL TABLE

SW1	SW2	SW3	Divide Ratio
L	L	L	80
L	L	H	40
L	H	L	40
L	H	H	20
H	L	L	40
H	L	H	20
H	H	L	20
H	H	H	10

NOTE: SW1, SW2 and SW3: H = V<sub>CC</sub>, L = Open.

Table 2. MAXIMUM RATINGS

Rating	Symbol	Value	Unit
Power Supply Voltage, Pin 2	V <sub>CC</sub>	-0.5 to 7.0	Vdc
Operating Temperature Range	T <sub>A</sub>	-40 to 85	°C
Storage Temperature Range	T <sub>stg</sub>	-65 to 150	°C
Maximum Output Current, Pin 4	I <sub>O</sub>	10	mA

Maximum ratings are those values beyond which device damage can occur. Maximum ratings applied to the device are individual stress limit values (not normal operating conditions) and are not valid simultaneously. If these limits are exceeded, device functional operation is not implied, damage may occur and reliability may be affected.

NOTE: ESD data available upon request.



ON Semiconductor®

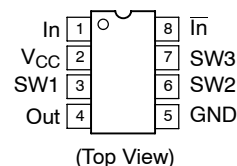
<http://onsemi.com>

### MARKING DIAGRAM



- A = Assembly Location
- L = Wafer Lot
- Y = Year
- W = Work Week
- = Pb-Free Package

### PIN CONNECTIONS



### ORDERING INFORMATION

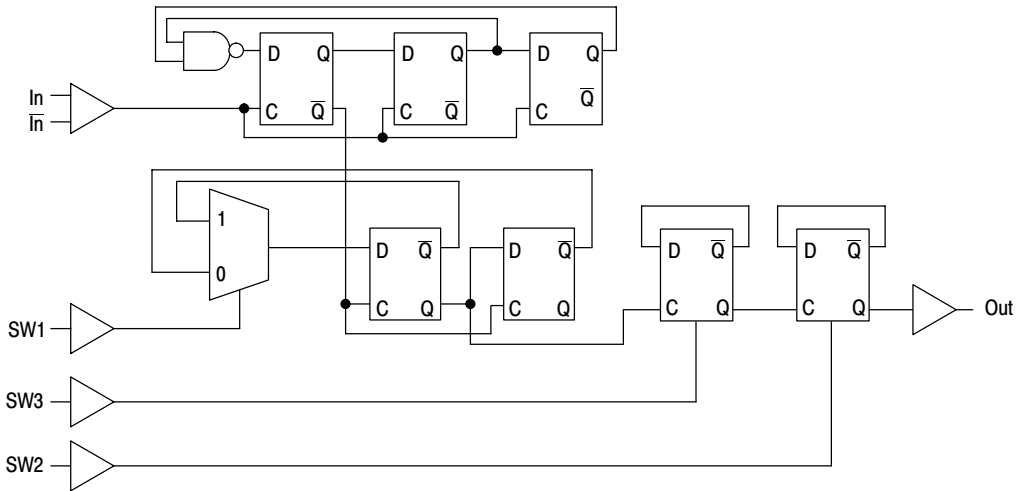
See detailed ordering and shipping information in the package dimensions section on page 3 of this data sheet.

# MC12080

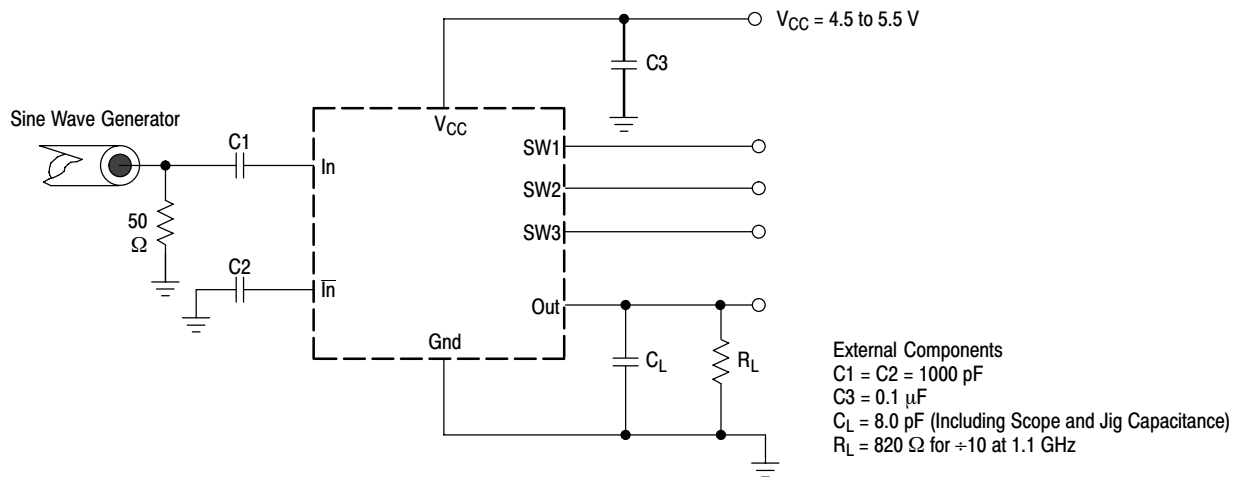
**Table 3. ELECTRICAL CHARACTERISTICS** ( $V_{CC} = 4.5$  to  $5.5$  V;  $T_A = -40$  to  $85^\circ\text{C}$ , unless otherwise noted.)

Characteristic	Symbol	Min	Typ	Max	Unit
Toggle Frequency (Sine Wave)	ft	0.1	1.4	1.1	GHz
Supply Current Output (Pin 2)	$I_{CC}$	-	3.7	5.0	mA
Input Voltage Sensitivity 100 to 250 MHz 250 to 1100 MHz	$V_{in}$	400 100	- -	1000 1000	mVpp
Divide Ratio Control Input High (SW1, SW2, SW3)	$V_{IH}$	$V_{CC} - 0.5$ V	$V_{CC}$	$V_{CC} + 0.5$ V	V
Divide Ratio Control Input Low (SW1, SW2, SW3)	$V_{IL}$	Open	Open	Open	-
Output Voltage Swing (Note 1) $R_L = 820 \Omega$ , $I_O = 4.0$ mA for $\pm 10$ $R_L = 1.6$ k $\Omega$ , $I_O = 2.1$ mA for $\pm 20$ $R_L = 3.3$ k $\Omega$ , $I_O = 1.1$ mA for $\pm 40$ $R_L = 6.2$ k $\Omega$ , $I_O = 0.57$ mA for $\pm 80$	$V_{out}$	0.8	1.2	-	V <sub>pp</sub>

1. Assumes 8.0 pF load and 1.1 GHz input frequency (typical),  $I_O$  at  $V_{CC} = 5.0$  V and  $T_A = 25^\circ\text{C}$ .

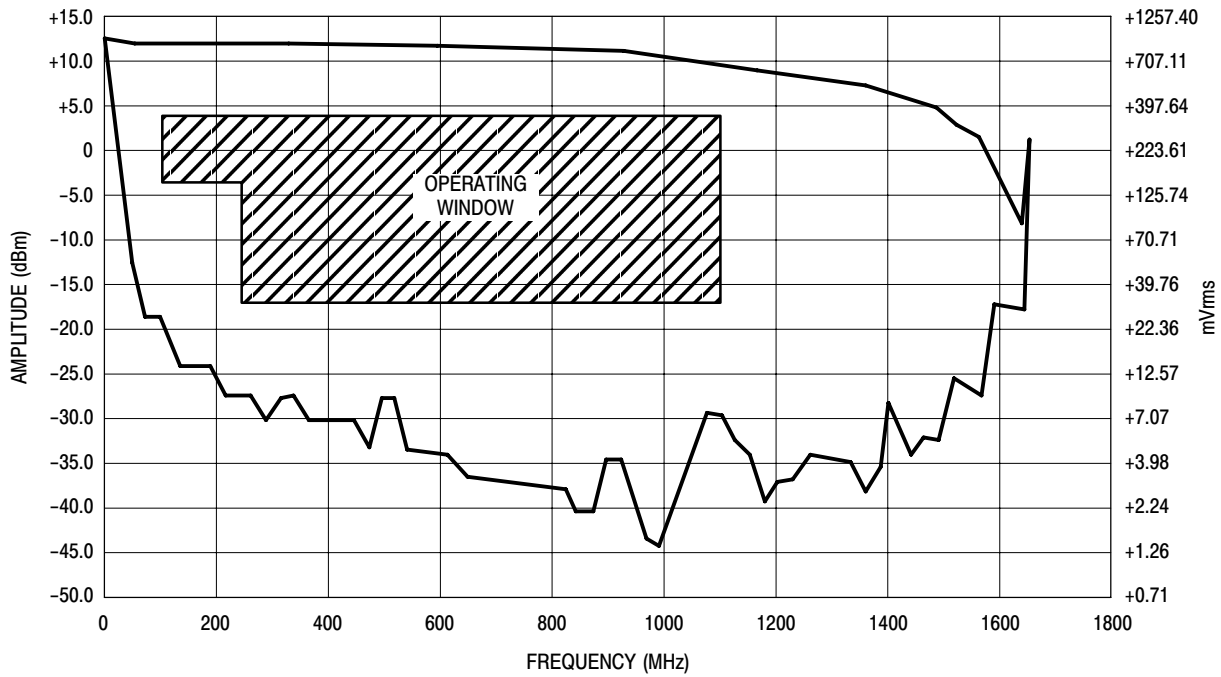


**Figure 1. Logic Diagram**

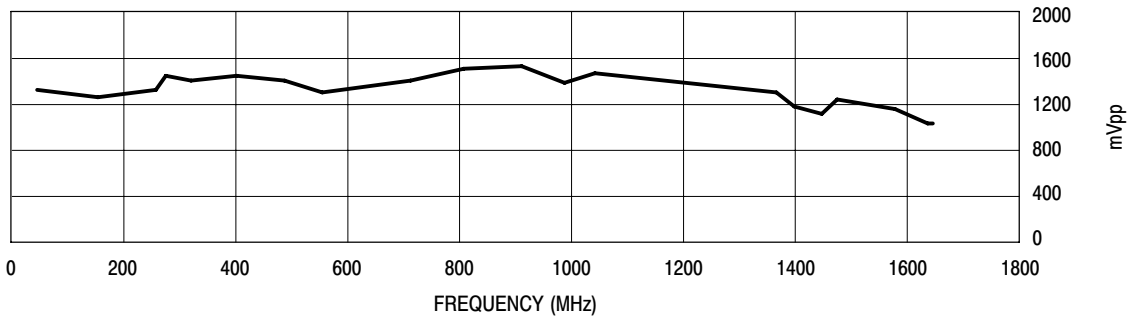


**Figure 2. AC Test Circuit**

# MC12080



**Figure 3. Input Signal Amplitude versus Input Frequency**



**Figure 4. Output Amplitude versus Input Frequency**

## ORDERING INFORMATION

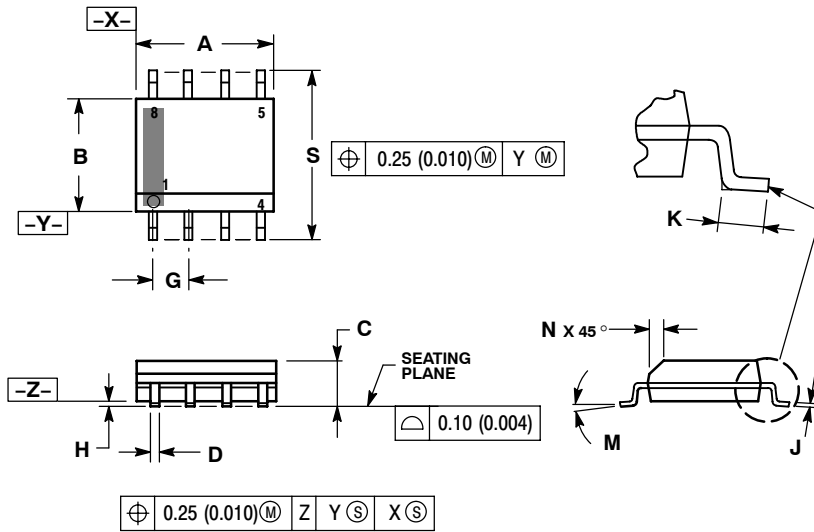
Device	Package	Shipping <sup>†</sup>
MC12080D	SOIC-8	98 Units / Rail
MC12080DG	SOIC-8 (Pb-Free)	98 Units / Rail
MC12080DR2	SOIC-8	2500 / Tape & Reel
MC12080DR2G	SOIC-8 (Pb-Free)	2500 / Tape & Reel

<sup>†</sup>For information on tape and reel specifications, including part orientation and tape sizes, please refer to our Tape and Reel Packaging Specifications Brochure, BRD8011/D.

# MC12080

## PACKAGE DIMENSIONS

### SOIC-8 NB CASE 751-07 ISSUE AG

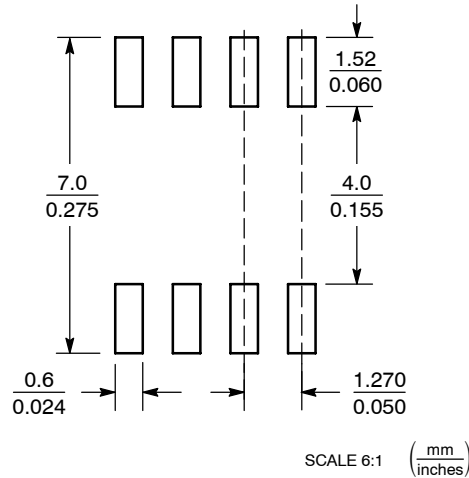


#### NOTES:

1. DIMENSIONING AND TOLERANCING PER ANSI Y14.5M, 1982.
2. CONTROLLING DIMENSION: MILLIMETER.
3. DIMENSION A AND B DO NOT INCLUDE MOLD PROTRUSION.
4. MAXIMUM MOLD PROTRUSION 0.15 (0.006) PER SIDE.
5. DIMENSION D DOES NOT INCLUDE DAMBAR PROTRUSION. ALLOWABLE DAMBAR PROTRUSION SHALL BE 0.127 (0.005) TOTAL IN EXCESS OF THE D DIMENSION AT MAXIMUM MATERIAL CONDITION.
6. 751-01 THRU 751-06 ARE OBSOLETE. NEW STANDARD IS 751-07.

DIM	MILLIMETERS		INCHES	
	MIN	MAX	MIN	MAX
A	4.80	5.00	0.189	0.197
B	3.80	4.00	0.150	0.157
C	1.35	1.75	0.053	0.069
D	0.33	0.51	0.013	0.020
G	1.27 BSC		0.050 BSC	
H	0.10	0.25	0.004	0.010
J	0.19	0.25	0.007	0.010
K	0.40	1.27	0.016	0.050
M	0°	8°	0°	8°
N	0.25	0.50	0.010	0.020
S	5.80	6.20	0.228	0.244

### SOLDERING FOOTPRINT\*



\*For additional information on our Pb-Free strategy and soldering details, please download the ON Semiconductor Soldering and Mounting Techniques Reference Manual, SOLDERRM/D.

ON Semiconductor and are registered trademarks of Semiconductor Components Industries, LLC (SCILLC). SCILLC reserves the right to make changes without further notice to any products herein. SCILLC makes no warranty, representation or guarantee regarding the suitability of its products for any particular purpose, nor does SCILLC assume any liability arising out of the application or use of any product or circuit, and specifically disclaims any and all liability, including without limitation special, consequential or incidental damages. "Typical" parameters which may be provided in SCILLC data sheets and/or specifications can and do vary in different applications and actual performance may vary over time. All operating parameters, including "Typicals" must be validated for each customer application by customer's technical experts. SCILLC does not convey any license under its patent rights nor the rights of others. SCILLC products are not designed, intended, or authorized for use as components in systems intended for surgical implant into the body, or other applications intended to support or sustain life, or for any other application in which the failure of the SCILLC product could create a situation where personal injury or death may occur. Should Buyer purchase or use SCILLC products for any such unintended or unauthorized application, Buyer shall indemnify and hold SCILLC and its officers, employees, subsidiaries, affiliates, and distributors harmless against all claims, costs, damages, and expenses, and reasonable attorney fees arising out of, directly or indirectly, any claim of personal injury or death associated with such unintended or unauthorized use, even if such claim alleges that SCILLC was negligent regarding the design or manufacture of the part. SCILLC is an Equal Opportunity/Affirmative Action Employer. This literature is subject to all applicable copyright laws and is not for resale in any manner.

### PUBLICATION ORDERING INFORMATION

**LITERATURE FULFILLMENT:**  
Literature Distribution Center for ON Semiconductor  
P.O. Box 61312, Phoenix, Arizona 85082-1312 USA  
**Phone:** 480-829-7710 or 800-344-3860 Toll Free USA/Canada  
**Fax:** 480-829-7709 or 800-344-3867 Toll Free USA/Canada  
**Email:** orderlit@onsemi.com

**N. American Technical Support:** 800-282-9855 Toll Free  
USA/Canada

**Japan:** ON Semiconductor, Japan Customer Focus Center  
2-9-1 Kamimeguro, Meguro-ku, Tokyo, Japan 153-0051  
**Phone:** 81-3-5773-3850

**ON Semiconductor Website:** <http://onsemi.com>

**Order Literature:** <http://www.onsemi.com/litorder>

For additional information, please contact your local Sales Representative.

MC12080/D