

# LMX2531

## High Performance Frequency Synthesizer System with Integrated VCO

### General Description

The LMX2531 is a low power, high performance frequency synthesizer system which includes a fully integrated delta-sigma PLL and VCO with fully integrated tank circuit. The third and fourth poles are also integrated and also adjustable. Also included are integrated ultra-low noise and high precision LDOs for the PLL and VCO which give higher supply noise immunity and also more consistent performance. When combined with a high quality reference oscillator, the LMX2531 generates very stable, low noise local oscillator signals for up and down conversion in wireless communication devices. The LMX2531 is a monolithic integrated circuit, fabricated in an advanced BiCMOS process. There are several different versions of this product in order to accommodate different frequency bands.

Device programming is facilitated using a three-wire MICROWIRE Interface that can operate down to 1.8 volts.

Supply voltage range is 2.8 to 3.2 Volts. The LMX2531 is available in a 36 pin 6x6x0.8 mm Lead-Free Leadless Lead-frame Package (LLP).

### Target Applications

- 3G Cellular Base Stations (WCDMA, TD-SCDMA, CDMA2000)
- 2G Cellular Base Stations (GSM/GPRS, EDGE, CDMA1xRTT)
- Wireless LAN
- Broadband Wireless Access
- Satellite Communications
- Wireless Radio
- Automotive
- CATV Equipment
- Instrumentation and Test Equipment
- RFID Readers

### Features

- **Multiple Frequency Options Available**
  - See Selection Guide Below
  - Frequencies from: 553 MHz - 3132 MHz
- **PLL Features**
  - Fractional-N Delta Sigma Modulator Order programmable up to 4th order
  - FastLock/Cycle Slip Reduction with Timeout Counter
  - Partially integrated, adjustable Loop Filter
  - Very low phase noise and spurs
- **VCO Features**
  - Integrated tank inductor
  - Low phase noise
- **Other Features**
  - 2.8 V to 3.2 V Operation
  - Low Power-Down Current
  - 1.8 V MICROWIRE Support
  - Package: 36 Lead LLP

Part	Low Band	High Band
LMX2531LQ1146E	553 - 592 MHz	1106 - 1184 MHz
LMX2531LQ1226E	592 - 634 MHz	1184 - 1268 MHz
LMX2531LQ1312E	634 - 680 MHz	1268 - 1360 MHz
LMX2531LQ1415E	680 - 735 MHz	1360 - 1470 MHz
LMX2531LQ1515E	725 - 790 MHz	1450 - 1580 MHz
LMX2531LQ1570E	765 - 818 MHz	1530 - 1636 MHz
LMX2531LQ1650E	795 - 850 MHz	1590 - 1700 MHz
LMX2531LQ1700E	831 - 885 MHz	1662 - 1770 MHz
LMX2531LQ1742	880 - 933 MHz	1760 - 1866 MHz
LMX2531LQ1778E	863 - 920 MHz	1726 - 1840 MHz
LMX2531LQ1910E	917 - 1014 MHz	1834 - 2028 MHz
LMX2531LQ2080E	952 - 1137 MHz	1904 - 2274 MHz
LMX2531LQ2265E	1089 - 1200 MHz	2178 - 2400 MHz
LMX2531LQ2570E	1168 - 1395 MHz	2336 - 2790 MHz
LMX2531LQ2820E	1355 - 1462 MHz	2710 - 2925 MHz
LMX2531LQ3010E	1455 - 1566 MHz	2910 - 3132 MHz

# Functional Block Diagram

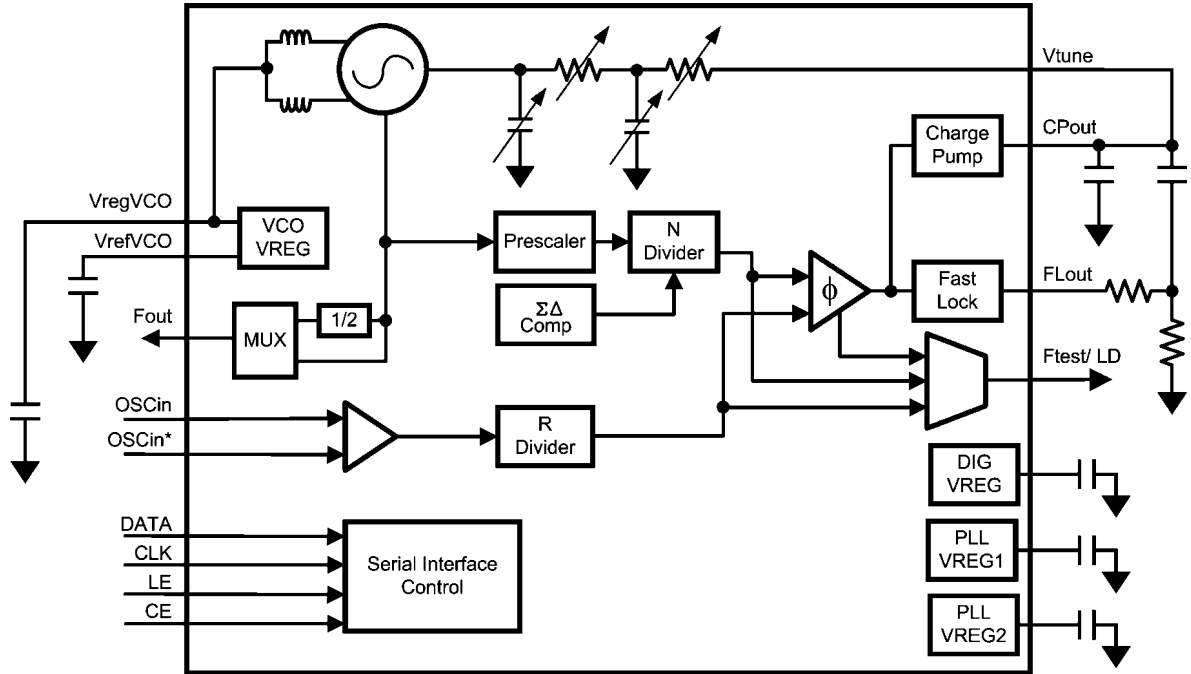

20101101

# Connection Diagrams

**36-Pin LLP (LQ) Package, D Version  
(LMX2531LQ1146E/1226E/1312E/1415E/1515E/2820E/3010E)**

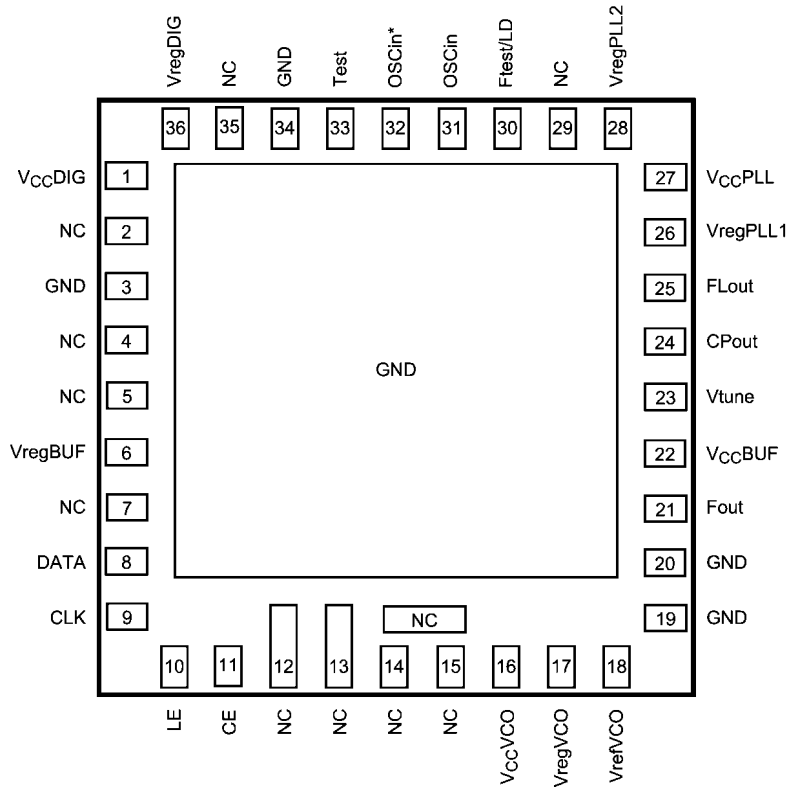

20101104

**36-Pin LLP (LQ) Package, A Version  
(All Other Versions)**

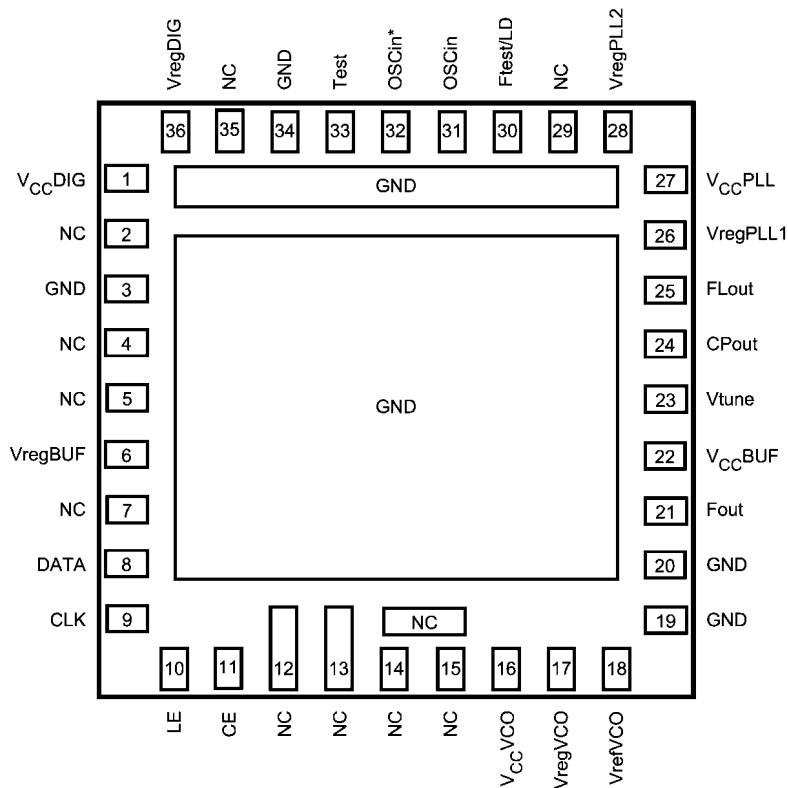

20101102

## Pin Descriptions

Pin #	Pin Name	I/O	Description
1	VccDIG	-	Power Supply for digital LDO circuitry. Input may range from 2.8 - 3.2 V. Bypass capacitors should be placed as close as possible to this pin and ground.
3	GND	-	Ground
2,4,5,7, 12, 13, 29, 35	NC	-	No Connect.
6	VregBUF	-	Internally regulated voltage for the VCO buffer circuitry. Connect to ground with a capacitor.
8	DATA	I	MICROWIRE serial data input. High impedance CMOS input. This pin must not exceed 2.75V. Data is clocked in MSB first. The last bits clocked in form the control or register select bits.
9	CLK	I	MICROWIRE clock input. High impedance CMOS input. This pin must not exceed 2.75V. Data is clocked into the shift register on the rising edge.
10	LE	I	MICROWIRE Latch Enable input. High impedance CMOS input. This pin must not exceed 2.75V. Data stored in the shift register is loaded into the selected latch register when LE goes HIGH.
11	CE	I	Chip Enable Input. High impedance CMOS input. This pin must not exceed 2.75V. When CE is brought high the LMX2531 is powered up corresponding to the internal power control bits. Although the part can be programmed when powered down, it is still necessary to reprogram the R0 register to get the part to re-lock.
14, 15	NC	-	No Connect. Do NOT ground.
16	VccVCO	-	Power Supply for VCO regulator circuitry. Input may range from 2.8 - 3.2 V. Bypass capacitors should be placed as close as possible to this pin and ground.
17	VregVCO	-	Internally regulated voltage for VCO circuitry. Not intended to drive an external load. Connect to ground with a capacitor and some series resistance.
18	VrefVCO	-	Internal reference voltage for VCO LDO. Not intended to drive an external load. Connect to ground with a capacitor.
19	GND	-	Ground for the VCO circuitry.
20	GND	-	Ground for the VCO Output Buffer circuitry.
21	Fout	O	Buffered RF Output for the VCO.
22	VccBUF	-	Power Supply for the VCO Buffer circuitry. Input may range from 2.8 - 3.2 V. Bypass capacitors should be placed as close as possible to this pin and ground.
23	Vtune	I	Tuning voltage input for the VCO. For connection to the CPout Pin through an external passive loop filter.
24	CPout	O	Charge pump output for PLL. For connection to Vtune through an external passive loop filter.
25	FLout	O	An open drain NMOS output which is used for FastLock or a general purpose output.
26	VregPLL1	-	Internally regulated voltage for PLL charge pump. Not intended to drive an external load. Connect to ground with a capacitor.
27	VccPLL	-	Power Supply for the PLL. Input may range from 2.8 - 3.2 V. Bypass capacitors should be placed as close as possible to this pin and ground.
28	VregPLL2	-	Internally regulated voltage for RF digital circuitry. Not intended to drive an external load. Connect to ground with a capacitor.
30	Ftest/LD	O	Multiplexed CMOS output. Typically used to monitor PLL lock condition.
31	OSCin	I	Oscillator input.
32	OSCin*	I	Oscillator complimentary input. When a single ended source is used, then a bypass capacitor should be placed as close as possible to this pin and be connected to ground.
33	Test	O	This pin is for test purposes and should be grounded for normal operation.
34	GND	-	Ground
36	VregDIG	-	Internally regulated voltage for LDO digital circuitry.

## Connection Diagram

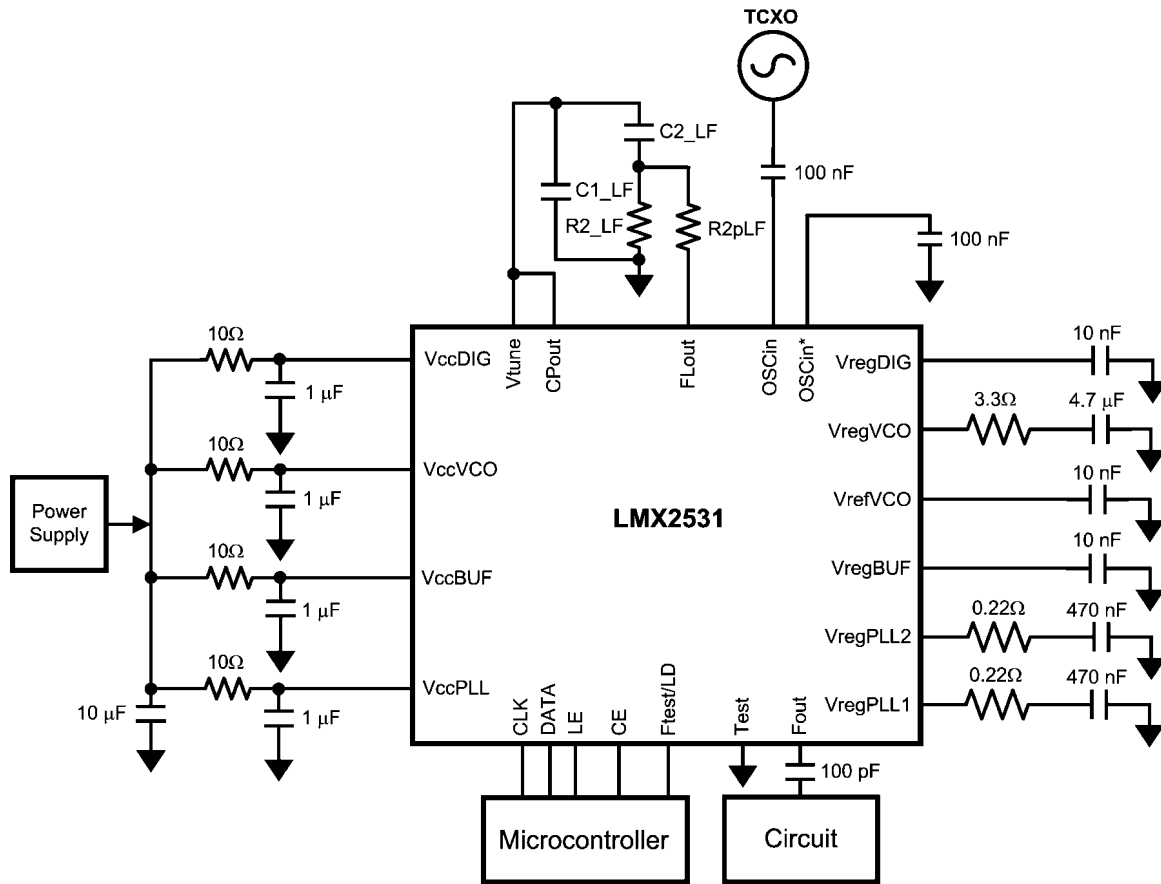

20101111

Pin(s)	Application Information
VccDIG VccVCO VccBUF VccPLL	These pins are inputs to voltage regulators. Because the LMX2531 contains internal regulators, the power supply noise rejection is very good and capacitors at this pin are not critical. An RC filter can be used to reduce supply noise, but if the capacitor is too large and is placed too close to these pins, they can sometimes cause phase noise degradation in the 100 - 300 kHz offset range. Recommended values are from open to 1 µF. The series resistors serve to filter power supply noise and isolate these pins from large capacitances.
VregDIG	There is not really any reason to use any other values than the recommended value of 10 nF
VrefVCO	If the VrefVCO capacitor is changed, it is recommended to keep this capacitor between 1/100 and 1/1000 of the value of the VregVCO capacitor.
VregVCO	Because this pin is the output of a regulator, there are stability concerns if there is not sufficient series resistance. For ceramic capacitors, the ESR (Equivalent Series Resistance) is too low, and it is recommended that a series resistance of 1 - 3.3Ω is necessary. If there is insufficient ESR, then there may be degradation in the phase noise, especially in the 100 - 300 kHz offset. Recommended values are from 1 µF to 10 µF.
VregPLL1 VregPLL2	The choice of the capacitor value at this pin involves a trade-off between integer spurs and phase noise in the 100 - 300 kHz offset range. Using a series resistor of about 220 mΩ in series with a capacitance that has an impedance of about 150 mΩ at the phase detector frequency seems to give an optimal trade-off. For instance, if the phase detector frequency is 2.5 MHz, then make this series capacitor 470 nF. If the phase detector frequency is 10 MHz, make this capacitance about 100 nF.
CLK DATA LE	Since the maximum voltage on these pins is less than the minimum Vcc voltage, level shifting may be required if the output voltage of the microcontroller is too high. This can be accomplished with a resistive divider.

Pin(s)	Application Information
CE	As with the CLK, DATA, and LE pins, level shifting may be required if the output voltage of the microcontroller is too high. A resistive divider or a series diode are two ways to accomplish this. The diode has the advantage that no current flows through it when the chip is powered down.
Ftest/LD	It is an option to use the lock detect information from this pin.
Fout	This is the high frequency output. This needs to be AC coupled, and matching may also be required. The value of the DC blocking capacitor may be changed, depending on the output frequency.
CPout Vtune	In most cases, it is sufficient to short these together, although there always the option of adding additional poles. C1_LF, C2_LF, and R2_LF are used in conjunction with the internal loop filter to make a fourth order loop filter.
R2pLF	This is the fastlock resistor, which can be useful in many cases, since the spurs are often better with low charge pump currents, and the internal loop filter can be adjusted during fastlock.
OScin	This is the reference oscillator input pin. It needs to be AC coupled.
OScin*	If the device is being driven single-ended, this pin needs to be shunted to ground with a capacitor.

## Absolute Maximum Ratings (Note 1)

If Military/Aerospace specified devices are required, please contact the National Semiconductor Sales Office/ Distributors for availability and specifications.

Parameter	Symbol	Ratings	Units
Power Supply Voltage	$V_{CC}$ (VccDIG, VccVCO, VccBUF, VccPLL)	-0.3 to 3.5	V
	All other pins (Except Ground)	-0.3 to 3.0	
Storage Temperature Range	$T_{STG}$	-65 to 150	°C
Lead Temperature (solder 4 sec.)	$T_L$	+ 260	°C

## Recommended Operating Conditions

Parameter	Symbol	Min	Typ	Max	Units
Power Supply Voltage (VccDig, VccVCO, VccBUF)	$V_{CC}$	2.8	3.0	3.2	V
Serial Interface and Power Control Voltage	$V_i$	0		2.75	V
Ambient Temperature (Note 5)	$T_A$	-40		+85	°C

**Note 1:** Absolute Maximum Ratings indicate limits beyond which damage to the device may occur. Recommended Operating Conditions indicate conditions for which the device is intended to be functional, but do not guarantee specific performance limits. For guaranteed specifications and test conditions, see the Electrical Characteristics. The guaranteed specifications apply only to the test conditions listed.

## Electrical Characteristics ( $V_{CC} = 3.0\text{ V}$ , $-40^{\circ}\text{C} \leq T_A \leq 85^{\circ}\text{C}$ ; except as specified.)

Symbol	Parameter	Conditions	Min	Typ	Max	Units	
<b>Current Consumption</b>							
$I_{CC}$	Power Supply Current Power Supply Current	Divider Disabled	LMX2531LQ2265E /2570E		38	44	mA
			LMX2531LQ2820E /3010E		38	46	
			All Other Options		34	41	
		Divider Enabled	LMX2531LQ2265E /2570E		41	49	
			LMX2531LQ2820E /3010E		44	52	
			All Other Options		37	46	
$I_{CCPD}$	Power Down Current	CE = 0 V, Part Initialized		7		$\mu\text{A}$	
<b>Oscillator</b>							
$I_{IHOSC}$	Oscillator Input High Current	$V_{IH} = 2.75\text{ V}$			100	$\mu\text{A}$	
$I_{ILOSC}$	Oscillator Input Low Current	$V_{IL} = 0$	-100			$\mu\text{A}$	
$f_{OSCI}$	Frequency Range	(Note 2)	5		80	MHz	
$V_{OSCI}$	Oscillator Sensitivity		0.5		2.0	Vpp	
<b>PLL</b>							
$f_{PD}$	Phase Detector Frequency				32	MHz	
$I_{CPout}$	Charge Pump Output Current Magnitude	ICP = 0		90		$\mu\text{A}$	
		ICP = 1		180		$\mu\text{A}$	
		ICP = 3		360		$\mu\text{A}$	
		ICP = 15		1440		$\mu\text{A}$	
$I_{CPoutTRI}$	CP TRI-STATE Current	$0.4\text{ V} < V_{CPout} < 2.0\text{ V}$		2	10	nA	
$I_{CPoutMM}$	Charge Pump Sink vs. Source Mismatch	$V_{CPout} = 1.2\text{ V}$ $T_A = 25^{\circ}\text{C}$		2	8	%	
$I_{CPoutV}$	Charge Pump Current vs. CP Voltage Variation	$0.4\text{ V} < V_{CPout} < 2.0\text{ V}$ $T_A = 25^{\circ}\text{C}$		4		%	
$I_{CPoutT}$	CP Current vs. Temperature Variation	$V_{CPout} = 1.2\text{ V}$		8		%	
LN(f)	Normalized PLL 1/f Noise $LN_{PLL\_flicker}(10\text{ kHz})$ (Note 3)	ICP = 1X Charge Pump Gain		-94		dBc/Hz	
		ICP = 16X Charge Pump Gain		-104			
	Normalized PLL Noise Floor $LN_{PLL\_flat}$ (Note 4)	ICP = 1X Charge Pump Gain		-202		dBc/Hz	
		ICP = 16X Charge Pump Gain		-212			



Symbol	Parameter	Conditions	Min	Typ	Max	Units
<b>VCO Frequencies</b>						
$f_{\text{Fout}}$	Operating Frequency Range (All options have a frequency divider, this applies before the divider. The frequency after the divider is half of what is shown)	LMX2531LQ1146E	1106		1184	MHz
		LMX2531LQ1226E	1184		1268	
		LMX2531LQ1312E	1268		1360	
		LMX2531LQ1415E	1360		1470	
		LMX2531LQ1515E	1450		1580	
		LMX2531LQ1570E	1530		1636	
		LMX2531LQ1650E	1590		1700	
		LMX2531LQ1700E	1662		1770	
		LMX2531LQ1742	1760		1866	
		LMX2531LQ1778E	1726		1840	
		LMX2531LQ1910E	1834		2028	
		LMX2531LQ2080E	1904		2274	
		LMX2531LQ2265E	2178		2400	
		LMX2531LQ2570E	2336		2790	
		LMX2531LQ2820E	2710		2925	
LMX2531LQ3010E	2910		3132			

Symbol	Parameter	Conditions	Min	Typ	Max	Units	
<b>Other VCO Specifications</b>							
$\Delta T_{CL}$	Maximum Allowable Temperature Drift for Continuous Lock (Note 5)	LMX2531LQ1742	65			°C	
		LMX2531LQ1570E/1650E/1146E/1226/1312E/1415E/1515E	90				
		LMX2531LQ1700E/1778E/1910E/2080E/2265E/2570E/2820E/3010E	125				
$P_{Fout}$	Output Power to a 50 $\Omega$ Load (Applies across entire tuning range.)	Divider Disabled	LMX2531LQ1146E	1	4.0	7	dBm
			LMX2531LQ1226E	1	3.5	7	
			LMX2531LQ1312E	1	3.5	7	
			LMX2531LQ1415E	0	3.0	6	
			LMX2531LQ1515E	-1	2.5	5	
			LMX2531LQ1570E	2	4.5	8	
			LMX2531LQ1650E	2	4.5	8	
			LMX2531LQ1700E	1	3.5	7	
			LMX2531LQ1742	1	3.5	7	
			LMX2531LQ1778E	1	3.5	7	
			LMX2531LQ1910E	1	3.5	7	
			LMX2531LQ2080E	1	3.5	7	
			LMX2531LQ2265E	1	3.5	7	
			LMX2531LQ2570E	0	3.0	6	
			LMX2531LQ2820E	-0.5	2.5	5.5	
		LMX2531LQ3010E	-1.5	1.5	4.5		
		Divider Enabled	LMX2531LQ1146E	-1	2.0	5	dBm
			LMX2531LQ1226E	-1	2.0	5	
			LMX2531LQ1312E	-1	1.5	4	
			LMX2531LQ1415E	-2	0.5	3	
			LMX2531LQ1515E	-2	0.5	3	
			LMX2531LQ1570E	1	3.0	6	
			LMX2531LQ1650E	1	3.0	6	
			LMX2531LQ1700E	1	3.0	6	
			LMX2531LQ1742	1	3.0	6	
			LMX2531LQ1778E	1	3.0	6	
			LMX2531LQ1910E	1	3.0	6	
LMX2531LQ2080E	0		2.5	5			
LMX2531LQ2265E	0	2.5	5				
LMX2531LQ2570E	-1	1.5	4				
LMX2531LQ2820E	-2.5	0	2.5				
LMX2531LQ3010E	-3	-0.5	2				

Symbol	Parameter	Conditions		Min	Typ	Max	Units
$K_{V_{tune}}$	Fine Tuning Sensitivity (When a range is displayed in the typical column, indicates the lower sensitivity is typical at the lower end of the tuning range, and the higher tuning sensitivity is typical at the higher end of the tuning range.)	LMX2531LQ1146E			2.5 -5.5		MHz/V
		LMX2531LQ1226E			3-6		
		LMX2531LQ1312E			3-6		
		LMX2531LQ1415E			3.5 -6.5		
		LMX2531LQ1515E			4-7		
		LMX2531LQ1570E			4-7		
		LMX2531LQ1650E			4-7		
		LMX2531LQ1700E			6-10		
		LMX2531LQ1742			4-7		
		LMX2531LQ1778E			6-10		
		LMX2531LQ1910E			8-14		
		LMX2531LQ2080E			9-20		
		LMX2531LQ2265E			10-16		
		LMX2531LQ2570E			10-23		
		LMX2531LQ2820E			12-28		
LMX2531LQ3010E			13-29				
$HS_{Fout}$	Harmonic Suppression (Applies Across Entire Tuning Range)	2nd Harmonic 50 $\Omega$ Load	Divider Disabled	LMX2531LQ1146E /1226E/1312E /1415E/1515E	-35	-25	dBc
				LMX2531LQ2820E /3010E	-40		
				All Other Options	-30	-25	
			Divider Enabled	LMX2531LQ1146E /1226E/1312E /1415E/1515E	-30	-20	
				LMX2531LQ2820E /3010E	-30	-15	
				All Other Options	-20	-15	
		3rd Harmonic 50 $\Omega$ Load	Divider Disabled	LMX2531LQ1146E /1226E/1312E	-35	-30	
				LMX2531LQ2820E /3010E	-50		
				All Other Options	-40	-35	
			Divider Enabled	LMX2531LQ1146E /1226E/1312E /1570E/1650E	-20	-15	
				LMX2531LQ2820E /3010E	-40	-20	
				All Other Options	-25	-20	
$PUSH_{Fout}$	Frequency Pushing	$C_{reg} = 0.1 \mu F$ , $V_{DD} \pm 100mV$ , Open Loop			300		kHz/V
$PULL_{Fout}$	Frequency Pulling	VSWR = 2:1, Open Loop				$\pm 600$	kHz
$Z_{Fout}$	Output Impedance				50		$\Omega$

Symbol	Parameter	Conditions	Min	Typ	Max	Units
<b>VCO Phase Noise (Note 6)</b>						
$L(f)_{Fout}$	Phase Noise (LMX2531LQ1146E)	$f_{Fout} = 1146 \text{ MHz}$ DIV2 = 0	10 kHz Offset		-96	dBc/Hz
			100 kHz Offset		-121	
			1 MHz Offset		-142	
			5 MHz Offset		-156	
		$f_{Fout} = 573 \text{ MHz}$ DIV2 = 1	10 kHz Offset		-101	
			100 kHz Offset		-126	
			1 MHz Offset		-147	
			5 MHz Offset		-156	
$L(f)_{Fout}$	Phase Noise (LMX2531LQ1226E)	$f_{Fout} = 1226 \text{ MHz}$ DIV2 = 0	10 kHz Offset		-95	dBc/Hz
			100 kHz Offset		-121	
			1 MHz Offset		-142	
			5 MHz Offset		-155	
		$f_{Fout} = 613 \text{ MHz}$ DIV2 = 1	10 kHz Offset		-101	
			100 kHz Offset		-126	
			1 MHz Offset		-147	
			5 MHz Offset		-155	
$L(f)_{Fout}$	Phase Noise (LMX2531LQ1312E)	$f_{Fout} = 1314 \text{ MHz}$ DIV2 = 0	10 kHz Offset		-95	dBc/Hz
			100 kHz Offset		-121	
			1 MHz Offset		-140	
			5 MHz Offset		-154	
		$f_{Fout} = 657 \text{ MHz}$ DIV2 = 1	10 kHz Offset		-101	
			100 kHz Offset		-126	
			1 MHz Offset		-146	
			5 MHz Offset		-154	
$L(f)_{Fout}$	Phase Noise (LMX2531LQ1415E)	$f_{Fout} = 1415 \text{ MHz}$ DIV2 = 0	10 kHz Offset		-95	dBc/Hz
			100 kHz Offset		-121	
			1 MHz Offset		-141	
			5 MHz Offset		-154	
		$f_{Fout} = 707.5 \text{ MHz}$ DIV2 = 1	10 kHz Offset		-100	
			100 kHz Offset		-126	
			1 MHz Offset		-146	
			5 MHz Offset		-154	
$L(f)_{Fout}$	Phase Noise (LMX2531LQ1515E)	$f_{Fout} = 1515 \text{ MHz}$ DIV2 = 0	10 kHz Offset		-96	dBc/Hz
			100 kHz Offset		-122	
			1 MHz Offset		-142	
			5 MHz Offset		-153	
		$f_{Fout} = 757.5 \text{ MHz}$ DIV2 = 1	10 kHz Offset		-99	
			100 kHz Offset		-125	
			1 MHz Offset		-145	
			5 MHz Offset		-154	
$L(f)_{Fout}$	Phase Noise (LMX2531LQ1570E)	$f_{Fout} = 1583 \text{ MHz}$ DIV2 = 0	10 kHz Offset		-93	dBc/Hz
			100 kHz Offset		-118	
			1 MHz Offset		-140	
			5 MHz Offset		-154	
		$f_{Fout} = 791.5 \text{ MHz}$ DIV2 = 1	10 kHz Offset		-99	
			100 kHz Offset		-122	
			1 MHz Offset		-144	
			5 MHz Offset		-155	

Symbol	Parameter	Conditions		Min	Typ	Max	Units
$L(f)_{Fout}$	Phase Noise (LMX2531LQ1650E)	$f_{Fout} = 1645 \text{ MHz}$ DIV2 = 0	10 kHz Offset		-93		dBc/Hz
			100 kHz Offset		-118		
			1 MHz Offset		-140		
			5 MHz Offset		-154		
		$f_{Fout} = 822.5 \text{ MHz}$ DIV2 = 1	10 kHz Offset		-99		
			100 kHz Offset		-122		
			1 MHz Offset		-144		
			5 MHz Offset		-155		
$L(f)_{Fout}$	Phase Noise (LMX2531LQ1700E)	$f_{Fout} = 1716 \text{ MHz}$ DIV2 = 0	10 kHz Offset		-92		dBc/Hz
			100 kHz Offset		-117		
			1 MHz Offset		-139		
			5 MHz Offset		-153		
		$f_{Fout} = 858 \text{ MHz}$ DIV2 = 1	10 kHz Offset		-98		
			100 kHz Offset		-122		
			1 MHz Offset		-144		
			5 MHz Offset		-154		
$L(f)_{Fout}$	Phase Noise (LMX2531LQ1742)	$f_{Fout} = 1813 \text{ MHz}$ DIV2 = 0	10 kHz Offset		-92		dBc/Hz
			100 kHz Offset		-117		
			1 MHz Offset		-140		
			5 MHz Offset		-152		
		$f_{Fout} = 906.5 \text{ MHz}$ DIV2 = 1	10 kHz Offset		-99		
			100 kHz Offset		-122		
			1 MHz Offset		-143		
			5 MHz Offset		-152		
$L(f)_{Fout}$	Phase Noise (LMX2531LQ1778E)	$f_{Fout} = 1783 \text{ MHz}$ DIV2 = 0	10 kHz Offset		-92		dBc/Hz
			100 kHz Offset		-117		
			1 MHz Offset		-139		
			5 MHz Offset		-152		
		$f_{Fout} = 891.5 \text{ MHz}$ DIV2 = 1	10 kHz Offset		-97		
			100 kHz Offset		-122		
			1 MHz Offset		-144		
			5 MHz Offset		-154		
$L(f)_{Fout}$	Phase Noise (LMX2531LQ1910E)	$f_{Fout} = 1931 \text{ MHz}$ DIV2 = 0	10 kHz Offset		-89		dBc/Hz
			100 kHz Offset		-115		
			1 MHz Offset		-138		
			5 MHz Offset		-151		
		$f_{Fout} = 965.5 \text{ MHz}$ DIV2 = 1	10 kHz Offset		-95		
			100 kHz Offset		-121		
			1 MHz Offset		-143		
			5 MHz Offset		-155		
$L(f)_{Fout}$	Phase Noise (LMX2531LQ2080E)	$f_{Fout} = 2089 \text{ MHz}$ DIV2 = 0	10 kHz Offset		-87		dBc/Hz
			100 kHz Offset		-113		
			1 MHz Offset		-136		
			5 MHz Offset		-150		
		$f_{Fout} = 1044.5 \text{ MHz}$ DIV2 = 1	10 kHz Offset		-93		
			100 kHz Offset		-119		
			1 MHz Offset		-142		
			5 MHz Offset		-154		

Symbol	Parameter	Conditions	Min	Typ	Max	Units		
$L(f)_{Fout}$	Phase Noise (LMX2531LQ2265E)	$f_{Fout} = 2264$ MHz DIV2 = 0	10 kHz Offset		-88		dBc/Hz	
			100 kHz Offset		-113			
			1 MHz Offset		-136			
			5 MHz Offset		-150			
		$f_{Fout} = 1132$ MHz DIV2 = 1	10 kHz Offset		-94			
			100 kHz Offset		-118			
			1 MHz Offset		-141			
			5 MHz Offset		-154			
$L(f)_{Fout}$	Phase Noise (LMX2531LQ2570E)	$f_{Fout} = 2563$ MHz DIV2 = 0	10 kHz Offset		-86		dBc/Hz	
			100 kHz Offset		-112			
			1 MHz Offset		-135			
			5 MHz Offset		-149			
		$f_{Fout} = 1281.5$ MHz DIV2 = 1	10 kHz Offset		-91			
			100 kHz Offset		-117			
			1 MHz Offset		-139			
			5 MHz Offset		-152			
$L(f)_{Fout}$	Phase Noise (LMX2531LQ2820E)	$f_{Fout} = 2818$ MHz DIV2 = 0	10 kHz Offset		-84		dBc/Hz	
			100 kHz Offset		-111			
			1 MHz Offset		-133			
			5 MHz Offset		-148			
		$f_{Fout} = 1409$ MHz DIV2 = 1	10 kHz Offset		-90			
			100 kHz Offset		-117			
			1 MHz Offset		-138			
			5 MHz Offset		-150			
$L(f)_{Fout}$	Phase Noise (LMX2531LQ3010E)	$f_{Fout} = 3021$ MHz DIV2 = 0	10 kHz Offset		-83		dBc/Hz	
			100 kHz Offset		-110			
			1 MHz Offset		-132			
			5 MHz Offset		-147			
		$f_{Fout} = 1510.5$ MHz DIV2 = 1	10 kHz Offset		-88			
			100 kHz Offset		-116			
			1 MHz Offset		-137			
			5 MHz Offset		-148			

Symbol	Parameter	Conditions	Min	Typ	Max	Units
<b>Digital Interface (DATA, CLK, LE, CE, Ftest/LD, FLout)</b>						
V <sub>IH</sub>	High-Level Input Voltage		1.6		2.75	V
V <sub>IL</sub>	Low-Level Input Voltage				0.4	V
I <sub>IH</sub>	High-Level Input Current	V <sub>IH</sub> = 1.75	-3.0		3.0	μA
I <sub>IL</sub>	Low-Level Input Current	V <sub>IL</sub> = 0 V	-3.0		3.0	μA
V <sub>OH</sub>	High-Level Output Voltage	I <sub>OH</sub> = 500 μA	2.0	2.65		V
V <sub>OL</sub>	Low-Level Output Voltage	I <sub>OL</sub> = -500 μA		0.0	0.4	V
<b>MICROWIRE Timing</b>						
t <sub>CS</sub>	Data to Clock Set Up Time	See Data Input Timing	25			ns
t <sub>CH</sub>	Data to Clock Hold Time	See Data Input Timing	20			ns
t <sub>CWH</sub>	Clock Pulse Width High	See Data Input Timing	25			ns
t <sub>CWL</sub>	Clock Pulse Width Low	See Data Input Timing	25			ns
t <sub>ES</sub>	Clock to Enable Set Up Time	See Data Input Timing	25			ns
t <sub>CES</sub>	Enable to Clock Set Up Time	See Data Input Timing	25			ns
t <sub>EWH</sub>	Enable Pulse Width High	See Data Input Timing	25			ns

**Note 2:** There are program bits that need to be set based on the OSCin frequency. Refer to the following sections: 2.7.8 XTLSEL[2:0] -- Crystal Select, 2.8.1 XTLDIV[1:0] -- Division Ratio for the Crystal Frequency, 2.8.2 XTLMAN[11:0] -- Manual Crystal Mode, 2.9.1 XTLMAN2 -- MANUAL CRYSTAL MODE SECOND ADJUSTMENT, and 2.9.2 LOCKMODE -- FREQUENCY CALIBRATION MODE. Not all bit settings can be used for all frequency choices of OSCin. For instance, automatic modes described in 2.7.8 XTLSEL[2:0] -- Crystal Select do not work below 8 MHz.

**Note 3:** One of the specifications for modeling PLL in-band phase noise is the PLL 1/f noise normalized to 1 GHz carrier frequency and 10 kHz offset, L<sub>PLL\_flicker</sub>(10 kHz). From this normalized index of PLL 1/f noise, the PLL 1/f noise can be calculated for any carrier and offset frequency as:

$$LN_{PLL\_flicker}(f) = L_{PLL\_flicker}(10\text{ kHz}) - 10 \cdot \log(10\text{ kHz} / f) + 20 \cdot \log(f_{out} / 1\text{ GHz})$$
 Flicker noise can dominate at low offsets from the carrier and has a 10 dB/decade slope and improves with higher charge pump currents and at higher offset frequencies. To accurately measure L<sub>PLL\_flicker</sub>(10 kHz) it is important to use a high phase detector frequency and a clean reference to make it such that this measurement is on the 10 dB/decade slope close to the carrier. L<sub>PLL\_flicker</sub>(f) can be masked by the reference oscillator performance if a low power or noisy source is used. The total PLL in-band phase noise performance is the sum of L<sub>PLL\_flicker</sub>(f) and L<sub>PLL\_flat</sub>. In other words, L<sub>PLL</sub>(f) = 10 · log(10(L<sub>PLL\_flat</sub> / 10) + 10(L<sub>PLL\_flicker</sub>(f) / 10))

**Note 4:** A specification used for modeling PLL in-band phase noise floor is the Normalized PLL noise floor, LN<sub>PLL\_flat</sub>, and is defined as:

$$LN_{PLL\_flat} = L(f) - 20 \cdot \log(N) - 10 \cdot \log(f_{PD})$$
 L<sub>PLL\_flat</sub> is the single side band phase noise in a 1 Hz Bandwidth and f<sub>PD</sub> is the phase detector frequency of the synthesizer. L<sub>PLL\_flat</sub> contributes to the total noise, L(f). To measure L<sub>PLL\_flat</sub> the offset frequency must be chosen sufficiently smaller than the loop bandwidth of the PLL, and yet large enough to avoid a substantial noise contribution from the reference and PLL flicker noise. L<sub>PLL\_flat</sub> can be masked by the reference oscillator performance if a low power or noisy source is used. The total PLL in-band phase noise performance is the sum of L<sub>PLL\_flicker</sub>(f) and L<sub>PLL\_flat</sub>. In other words, L<sub>PLL</sub>(f) = 10 · log(10(L<sub>PLL\_flat</sub> / 10) + 10(L<sub>PLL\_flicker</sub>(f) / 10))

**Note 5:** Maximum Allowable Temperature Drift for Continuous Lock is how far the temperature can drift in either direction from the value it was at the time that the R0 register was last programmed, and still have the part stay in lock. The action of programming the R0 register, even to the same value, activates a frequency calibration routine. This implies that the part will work over the entire frequency range, but if the temperature drifts more than the maximum allowable drift for continuous lock, then it will be necessary to reload the R0 register to ensure that it stays in lock. Regardless of what temperature the part was initially programmed at, the temperature can never drift outside the frequency range of -40°C ≤ T<sub>A</sub> ≤ 85°C without violating specifications.

**Note 6:** The VCO phase noise is measured assuming that the loop bandwidth is sufficiently narrow that the VCO noise dominates. The maximum limits apply only at center frequency and over temperature, assuming that the part is reloaded at each test frequency. Over frequency, the phase noise can vary 1 to 2 dB, with the worst case performance typically occurring at the highest frequency. Over temperature, the phase noise typically varies 1 to 2 dB, assuming the part is reloaded.

## Serial Data Timing Diagram

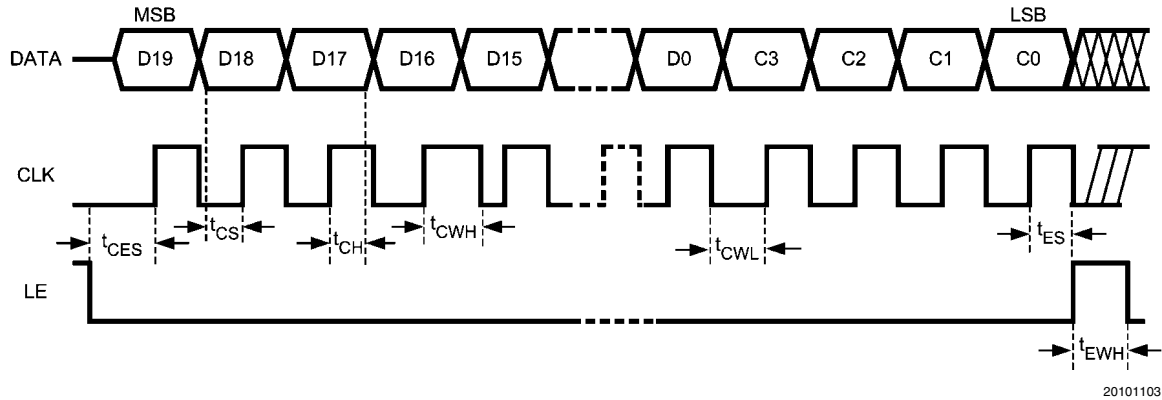

20101103

The DATA is clocked into a shift register on each rising edge of the CLK signal. On the rising edge of the LE signal, the data is sent from the shift registers to an actual counter. A slew rate of at least 30 V/ $\mu$ s is recommended for these signals. After the programming is complete, the CLK, DATA, and LE signals should be returned to a low state. Although it is strongly recommended to keep LE low after programming, LE can be kept high if bit R5[23] is changed to 0 (from its default value of 1). If this bit is changed, then the operation of the part is not guaranteed because it is not tested under these conditions. If the CLK and DATA lines are toggled while the in VCO is in lock, as is sometimes the case when these lines are shared with other parts, the phase noise may be degraded during the time of this programming.



## Typical Performance Characteristics

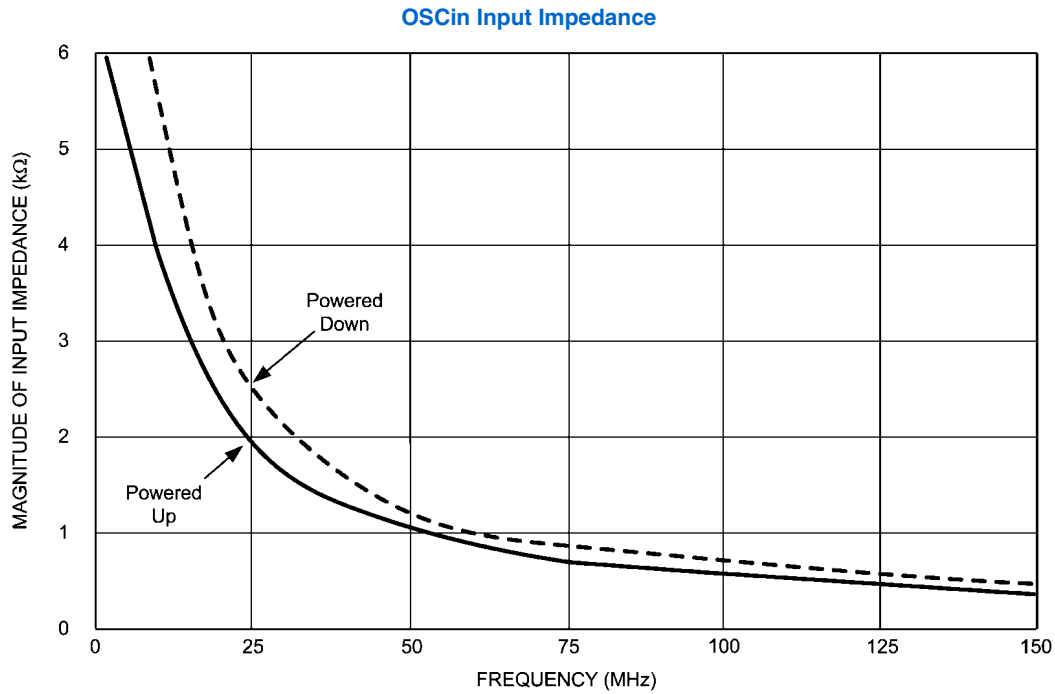

20101106

Frequency (MHz)	Powered Up (kΩ)			Powered Down (kΩ)		
	Real	Imaginary	Magnitude	Real	Imaginary	Magnitude
1	4.98	-2.70	5.66	6.77	-8.14	10.59
5	3.44	-3.04	4.63	5.73	-6.72	9.03
10	1.42	-2.67	3.02	1.72	-5.24	5.51
20	0.52	-1.63	1.71	0.53	-2.94	2.98
30	0.29	-1.22	1.25	0.26	-2.12	2.14
40	0.18	-0.92	0.94	0.17	-1.58	1.59
50	0.13	-0.74	0.75	0.14	-1.24	1.25
60	0.10	-0.63	0.64	0.10	-1.06	1.06
70	0.09	-0.56	0.56	0.09	-0.95	0.95
80	0.07	-0.50	0.50	0.08	-0.86	0.87
90	0.07	-0.46	0.46	0.07	-0.80	0.80
100	0.06	-0.41	0.42	0.07	-0.72	0.72
110	0.06	-0.37	0.38	0.07	-0.65	0.65
120	0.05	-0.34	0.34	0.06	-0.59	0.59
130	0.05	-0.32	0.32	0.06	-0.55	0.55
140	0.04	-0.29	0.30	0.05	-0.50	0.50
150	0.04	-0.27	0.28	0.05	-0.47	0.47

## 1.0 Functional Description

The LMX2531 is a low power, high performance frequency synthesizer system which includes the PLL, VCO, and partially integrated loop filter. The following sections give a discussion of the various blocks of this device.

### 1.1 REFERENCE OSCILLATOR INPUT

Because the VCO frequency calibration algorithm is based on clocks from the OSCin pin, there are certain bits that need to be set depending on the OSCin frequency. XTSEL (R6[22:20]) and XTLDIV (R7[9:8]) are both need to be set based on the OSCin frequency,  $f_{\text{OSCin}}$ . For some options and for low OSCin frequencies, the XTLMAN (R7[21:10]) and XTLMAN2 (R8[4]) words need to be set to the correct value.

### 1.2 R DIVIDER

The R divider divides the OSCin frequency down to the phase detector frequency. The R divider value, R, is restricted to the values of 1, 2, 4, 8, 16, and 32. If R is greater than 8, then this also puts restrictions on the fractional denominator, FDEN, than can be used. This is discussed in greater depth in later sections.

### 1.3 PHASE DETECTOR AND CHARGE PUMP

The phase detector compares the outputs of the R and N dividers and puts out a correction current corresponding to the phase error. The phase detector frequency,  $f_{\text{PD}}$ , can be calculated as follows:

$$f_{\text{PD}} = f_{\text{OSCin}} / R$$

Choosing  $R = 1$  yields the highest possible phase detector frequency and is optimum for phase noise, although there are restrictions on the maximum phase detector frequency which could force the R value to be larger. The far out PLL noise improves 3 dB for every doubling of the phase detector frequency, but at lower offsets, this effect is much less due to the PLL 1/f noise. Aside from getting the best PLL phase noise, higher phase detector frequencies also make it easier to filter the noise that the delta-sigma modulator produces, which peaks at an offset frequency of  $f_{\text{PD}}/2$  from the carrier. The LMX2531 also has 16 levels of charge pump currents and a highly flexible fractional modulus. Increasing the charge pump current improves the phase noise about 3 dB per doubling of the charge pump current, although there are small diminishing returns as the charge pump current increases.

From a loop filter design and PLL phase noise perspective, one might think to always design with the highest possible phase detector frequency and charge pump current. However, if one considers the worst case fractional spurs that occur at an output frequency equal to 1 channel spacing away from a multiple of the  $f_{\text{OSCin}}$ , then this gives reason to reconsider. If the phase detector frequency or charge pump currents are too high, then these spurs could be degraded, and the loop filter may not be able to filter these spurs as well as theoretically predicted. For optimal spur performance, a phase detector frequency around 2.5 MHz and a charge pump current of 1X are recommended.

### 1.4 N DIVIDER AND FRACTIONAL CIRCUITRY

The N divider in the LMX2531 includes fractional compensation and can achieve any fractional denominator between 1 and 4,194,303. The integer portion,  $N_{\text{Integer}}$ , is the whole part of the N divider value and the fractional portion,  $N_{\text{Fractional}}$ , is the remaining fraction. So in general, the total N divider value, N, is determined by:

$$N = N_{\text{Integer}} + N_{\text{Fractional}}$$

For example, if the phase detector frequency ( $f_{\text{PD}}$ ) was 10 MHz and the VCO frequency ( $f_{\text{VCO}}$ ) was 1736.1 MHz, then N would be 173.61. This would imply that  $N_{\text{Integer}}$  is 173 and  $N_{\text{Fractional}}$  is 61/100.  $N_{\text{Integer}}$  has some minimum value restrictions that arise due to the architecture of this divider. The first restrictions arise because the N divider value is actually formed by a quadruple modulus 16/17/20/21 prescaler, which creates minimum divide values.  $N_{\text{Integer}}$  is further restricted because the LMX2531 due to the fractional engine of the N divider.

The fractional word,  $N_{\text{Fractional}}$ , is a fraction formed with the NUM and DEN words. In the example used here with the fraction of 61/100, NUM = 61 and DEN = 100. The fractional denominator value, DEN, can be set from 2 to 4,194,303. The case of DEN=0 makes no sense, since this would cause an infinite N value; the case of 1 makes no sense either (but could be done), because integer mode should be used in these applications. All other values in this range, like 10, 32, 42, 734, or 4,000,000 are all valid. Once the fractional denominator, DEN, is determined, the fractional numerator, NUM, is intended to be varied from 0 to DEN-1.

In general, the fractional denominator, DEN, can be calculated by dividing the phase detector frequency by the greatest common divisor (GCD) of the channel spacing ( $f_{\text{CH}}$ ) and the phase detector frequency. If the channel spacing is not obvious, then it can be calculated as the greatest common divisor of all the desired VCO frequencies.

$$\text{FDEN} = k \cdot f_{\text{PD}} / \text{GCD}(f_{\text{PD}}, f_{\text{CH}})$$

$$k = 1, 2, 3 \dots$$

For example, consider the case of a 10 MHz phase detector frequency and a 200 kHz channel spacing at the VCO output. The greatest common divisor of 10 MHz and 200 kHz is just 200 kHz. If one takes 10 MHz divided by 200 kHz, the result is 50. So a fractional denominator of 50, or any multiple of 50 would work in this example. Now consider a case with a 10 MHz phase detector frequency and a 30 kHz channel spacing. The greatest common divisor of 10 MHz and 30 kHz is 10 kHz. The fractional denominator therefore must be a multiple 1000, since this is 10 MHz divided by 10 kHz. For a final example, consider an application with a fixed output frequency of 2110.8 MHz and a OSCin frequency of 19.68 MHz. If the phase detector frequency is chosen to be 19.68 MHz, then the channel spacing can be calculated as the greatest common multiple of 19.68 MHz and 2110.8 MHz, which is 240 kHz. The fractional denominator is therefore a multiple of 41, which is 19.68 MHz / 240 kHz. Refer to application note 1865 for more details on frequency planning.

To achieve a fractional N value, an integer N divider is modulated between different values. This gives rise to three main degrees of freedom with the LMX2531 delta sigma engine including the modulator order, dithering, and the way that the fractional portion is expressed. The first degree of freedom is the modulator order, which gives the user the ability to optimize for a particular application. The modulator order can be selected as zero (integer mode), two, three, or four. One simple technique to better understand the impact of the delta sigma fractional engine on noise and spurs is to tune the VCO to an integer channel and observe the impact of changing the modulator order from integer mode to a higher order. The higher the fractional modulator order is, the lower the spurs theoretically are. However, this is not always the case, and the higher order fractional modulator can sometimes give rise to additional spurious tones, but this is dependent on the application. The second degree of freedom with the LMX2531

delta sigma engine is dithering. Dithering is often effective in reducing these additional spurious tones, but can add phase noise in some situations. The third degree of freedom is the way that the fraction is expressed. For example, 1/10 can be expressed as 100000/1000000. Expressing the fraction in higher order terms sometimes improves the performance, particularly when dithering is used. In conclusion, there are some guidelines to getting the optimum choice of settings, but these optimum settings are application specific. Refer to application note 1879 for a much more detailed discussion on fractional PLLs and fractional spurs..

### 1.5 PARTIALLY INTEGRATED LOOP FILTER

The LMX2531 integrates the third pole (formed by R3 and C3) and fourth pole (formed by R4 and C4) of the loop filter. The values for C3, C4, R3, and R4 can also be programmed independently through the MICROWIRE interface and also R3 and R4 can be changed during FastLock™, for minimum lock time. The larger the values of these components, the stronger the attenuation of the internal loop filter. The maximum attenuation can be achieved by setting R3=R4=40 kΩ and C3=C4=100 pF while the minimum attenuation is achieved by disabling the loop filter by setting EN\_LPFLTR (R6[15]) to zero. Note that when the internal loop filter is disabled, there is still a small amount of input capacitance on front of the VCO on the order of 200 pF.

Since that the internal loop filter is on-chip, it is more effective at reducing certain spurs than the external loop filter. The higher order poles formed by the integrated loop filter are also helpful for attenuating noise due to the delta-sigma modulator. This noise produced by the delta-sigma modulator is outside the loop bandwidth and dependent on the modulator order. Although setting the filtering for maximum attenuation gives the best filtering, it puts increased restrictions on how wide the loop bandwidth of the system can be, which corresponds to the case where the shunt loop filter capacitor, C1, is zero. Increasing the charge pump current and/or the phase detector frequency increases the maximum attainable loop bandwidth when designing with the integrated filter. It is recommended to set the internal loop filter as high as possible without restricting the loop bandwidth of the system more than desired. If some setting between the minimum and maximum value is desired, it is preferable to reduce the resistor values before reducing the capacitor values since this will reduce the thermal noise contribution of the loop filter resistors. For design tools and more information on partially integrated loop filters, go to [www.national.com/wireless](http://www.national.com/wireless).

### 1.6 LOW NOISE, FULLY INTEGRATED VCO

The LMX2531 includes a fully integrated VCO, including the inductors. For optimum phase noise performance, this VCO has frequency and phase noise calibration algorithms. The frequency calibration algorithm is necessary because the

VCO internally divides up the frequency range into several bands, in order to achieve a lower tuning gain, and therefore better phase noise performance. The frequency calibration routine is activated any time that the R0 register is programmed. There are several bits including LOCKMODE and XTSEL that need to be set properly for this calibration to be performed in a reliable fashion. If the temperature shifts considerably and the R0 register is not programmed, then it can not drift more than the maximum allowable drift for continuous lock,  $\Delta T_{CL}$ , or else the VCO is not guaranteed to stay in lock. The phase noise calibration algorithm is necessary in order to achieve the lowest possible phase noise. Each version of the LMX2531, the VCO\_ACI\_SEL bit (R6[19:16]) needs to be set to the correct value to ensure the best possible phase noise.

The gain of the VCO can change considerably over frequency. It is lowest at the minimum frequency and highest at the maximum frequency. This range is specified in the electrical specifications section of the datasheet. When designing the loop filter, the following method is recommended to determine what VCO gain to design to. First, take the geometric mean of the minimum and maximum frequencies that are to be used. Then use a linear approximation to extrapolate the VCO gain. Suppose the application requires the LMX2531LQ2080E PLL to tune from 2100 to 2150 MHz. The geometric mean of these frequencies is  $\sqrt{2100 \times 2150}$  MHz = 2125 MHz. The VCO gain is specified as 9 MHz/V at 1904 MHz and 20 MHz/V at 2274 MHz. Over this range of 370 MHz, the VCO gain changes 11 MHz/V. So at 2125 MHz, the VCO gain would be approximately  $9 + (2125-1904) \times 11/370 = 15.6$  MHz/V. Although the VCO gain can change from part to part, this variation is small compared to how much the VCO gain can change over frequency.

The VCO frequency is related to the other frequencies and divider values as follows:

$$f_{VCO} = f_{PD} \times N = f_{OSCin} \times N / R$$

### 1.7 PROGRAMMABLE VCO DIVIDER

All options of the LMX2531 offer the option of dividing the VCO output by two to get half of the VCO frequency at the Fout pin. The channel spacing at the Fout pin is also divided by two as well. Because this divide by two is outside feedback path between the VCO and the PLL, enabling does require one to change the N divider, R divider, or loop filter values. When this divider is enabled, there will be some far-out phase noise contribution to the VCO noise. Note that the R0 register should be reprogrammed the first time after the DIV2 bit is enabled or disabled for optimal phase noise performance. The frequency at the Fout pin is related to the VCO frequency and divider value, D, as follows:

$$f_{Fout} = f_{VCO} / D$$

## 2.0 General Programming Information

The LMX2531 is programmed using 11 24-bit registers used to control the LMX2531 operation. A 24-bit shift register is used as a temporary register to indirectly program the on-chip registers. The shift register consists of a data field and an address field. The last 4 register bits, CTRL[3:0] form the address field, which is used to decode the internal register address. The remaining 20 bits form the data field DATA[19:0]. While LE is low, serial data is clocked into the shift register upon the rising edge of clock (data is programmed MSB first). When LE goes high, data is transferred from the data field into the selected register bank. Although there are actually 14 registers in this part, only a portion of them should be programmed, since the state of the other hidden registers (R13, R11, and R10) are set during the initialization sequence. Although it is possible to program these hidden registers, as well as a lot of bits that are defined to either '1' or '0', the user should not experiment with these hidden registers and bits, since the parts are not tested under these conditions and doing so will most likely degrade performance.

DATA[19:0]																				CONTROL[3:0]				
MSB																								LSB
D19	D18	D17	D16	D15	D14	D13	D12	D11	D10	D9	D8	D7	D6	D5	D4	D3	D2	D1	D0	C3	C2	C1	C0	

### 2.01 REGISTER LOCATION TRUTH TABLE

C3	C2	C1	C0	Data Address
1	1	0	0	R12
1	0	0	1	R9
1	0	0	0	R8
0	1	1	1	R7
0	1	1	0	R6
0	1	0	1	R5
0	1	0	0	R4
0	0	1	1	R3
0	0	1	0	R2
0	0	0	1	R1
0	0	0	0	R0

### 2.02 INITIALIZATION SEQUENCE

The initial loading sequence from a cold start is described below. The registers must be programmed in order shown. There must be a minimum of 10 ms between the time when R5 is last loaded and R1 is loaded to ensure time for the LDOs to power up properly.

REG.	23	22	21	20	19	18	17	16	15	14	13	12	11	10	9	8	7	6	5	4	3	2	1	0
	DATA[19:0]																				C3	C2	C1	C0
R5 INIT1	1	0	0	0	0	1	0	0	0	0	0	0	0	0	0	0	0	0	0	0	0	1	0	1
R5 INIT2	1	0	0	0	0	0	0	0	0	0	0	0	0	0	0	0	0	0	0	0	0	1	0	1
R5	1	0	0	0	0	0	0	0	0	0	0	0	0	1	1	1	1	1	1	1	0	1	0	1
R12	Program R12 as shown in the complete register map.																				1	1	0	0
R9	Program R9 as shown in the complete register map.																				1	0	0	1
R8	See individual section for Register R8 programming information. Programming of this register is necessary under specific circumstances.																				1	0	0	0
R7	See individual section for Register R7 programming information.																				0	1	1	1
R6	See individual section for Register R6 programming information.																				0	1	1	0
R4	See individual section for Register R4 programming information. Register R4 only needs to be programmed if FastLock is used.																				0	1	0	0
R3	See individual section for Register R3 programming information.																				0	0	1	1
R2	See individual section for Register R2 programming information.																				0	0	1	0
R1	See individual section for Register R1 programming information.																				0	0	0	1
R0	See individual section for Register R0 programming information.																				0	0	0	0

## 2.03 Complete Register Content Map

This table shows all the programmable bits for the LMX2531. No programming order or initialization sequence is implied by this table, only the location of the programming information.

RE	23	22	21	20	19	18	17	16	15	14	13	12	11	10	9	8	7	6	5	4	3	2	1	0
GIS	DATA[19:0]																							
TER																								
R0	N [7:0]							NUM [11:0]																
R1	0	0	1	ICP [3:0]			N [10:8]			NUM [21:12]														
R2	0	1	DEN [11:0]							R [5:0]														
R3	DIV 2	FD M	DITHER [1:0]	ORDER [1:0]	FOLD [3:0]			DEN [21:12]																
R4	0	0	ICPFL [3:0]			TOC [13:0]																		
R5	1	0	0	0	0	0	0	0	0	0	0	0	0	0	0	0	0	0	0	0	0	1	0	1
R6	0	XTLSEL [2:0]		VCO_ACI_SEL [3:0]			EN_LP_FLT [3:0]			R4_ADJ [1:0]	R4_ADJ_FL [1:0]	R3_ADJ [1:0]	R3_ADJ_FL [1:0]	C3_4_ADJ [2:0]										
R7	0	0	XTLMAN [11:0]							XTLDIV [1:0]														
R8	0	0	0	0	0	1	LOCK MODE																	
R9	0	0	0	0	0	0	0	0	0	0	0	0	0	0	0	0	0	0	0	0	0	0	0	0
R12	0	0	0	0	0	0	0	0	0	0	0	0	0	0	0	0	0	0	0	0	0	0	0	0

## 2.1 REGISTER R0

The action of programming the R0 register activates a frequency calibration routine for the VCO. This calibration is necessary to get the VCO to center the tuning voltage for optimal performance. If the temperature drifts considerably, then the PLL should stay in lock, provided that the temperature drift specification is not violated.

### 2.1.1 NUM[10:0] and NUM[21:12] -- Fractional Numerator

The NUM word is split between the R0 register and R1 register. The Numerator bits determine the fractional numerator for the delta sigma PLL. This value can go from 0 to 4095 when the FDM bit (R3[22]) is 0 (the other bits in this register are ignored), or 0 to 4194303 when the FDM bit is 1.

Fractional Numerator	NUM[21:12]										NUM[11:0]									
	0	0	0	0	0	0	0	0	0	0	0	0	0	0	0	0	0	0	0	0
0	0	0	0	0	0	0	0	0	0	0	0	0	0	0	0	0	0	0	0	0
...																				
409503	1	1	1	1	1	1	1	1	1	1	1	1	1	1	1	1	1	1	1	1
4096	0	0	0	0	0	0	0	0	0	0	1	0	0	0	0	0	0	0	0	0
...																				
4194303	1	1	1	1	1	1	1	1	1	1	1	1	1	1	1	1	1	1	1	1

Note that there are restrictions on the fractional numerator value depending on the R divider value if it is 16 or 32.

### 2.1.2 N[7:0] and N[10:8]

The N counter is 11 bits. 8 of these bits are located in the R0 register, and the remaining 3 (MSB bits) are located in the R1 register. The LMX2531 consists of an A, B, and C counter, which work in conjunction with the 16/17/20/21 prescaler in order to form the final N counter value.

N Value	N[10:8]				N[7:0]							
	C				B			A				
<55	Values less than 55 are prohibited.											
55	0	0	0	0	0	0	1	1	0	1	1	1
...												
2039	1	1	1	1	1	1	1	1	0	1	1	1

## 2.2 REGISTER R1

### 2.2.1 NUM[21:12]

These are the MSB bits in for the fractional numerator that already have been described.

### 2.2.2 N[10:8] -- 3 MSB Bits for the N Counter

These are the 2 MSB bits for the N counter, which were discussed in the R0 register section.

### 2.2.3 ICP[3:0] -- Charge Pump Current

This bit programs the charge pump current in from 90  $\mu\text{A}$  to 1440  $\mu\text{A}$  in 90  $\mu\text{A}$  steps. In general, higher charge pump currents yield better phase noise for the PLL, but also can cause higher spurs.

ICP	Charge Pump State	Typical Charge Pump Current at 3 Volts ( $\mu\text{A}$ )
0	1X	90
1	2X	180
2	3X	270
3	4X	360
4	5X	450
5	6X	540
6	7X	630
7	8X	720
8	9X	810
9	10X	900
10	11X	990
11	12X	1080
12	13X	1170
13	14X	1260
14	15X	1350
15	16X	1440

## 2.3 REGISTER R2

### 2.3.1 R[5:0] -- R Counter Value

These bits determine the phase detector frequency. The OSCin frequency is divided by this R counter value. Note that only the values of 1, 2, 4, 8, 16, and 32 are allowed.

R Value	Fractional Denominator Restrictions	R[5:0]					
0,3,5-7, 9-15,17-31, 33-63	n/a	These values are illegal.					
1	none	0	0	0	0	0	1
2	none	0	0	0	0	1	0
4	none	0	0	0	1	0	0
8	none	0	0	1	0	0	0
16	Must be divisible by 2	0	1	0	0	0	0
32	Must be divisible by 4	1	0	0	0	0	0

The R counter value can put some restrictions on the fractional denominator. In the case that it is 16, the fractional denominator must be divisible by 2, which is equivalent to saying that the LSB of the fractional denominator word is zero. In the case that the R counter is 32, the two LSB bits of the fractional denominator word must also be zero, which is equivalent to saying that the fractional denominator must be divisible by 4. Because the fractional denominator can be very large, this should cause no issues. For instance, if one wanted to achieve a fractional word of 1/65, and the R counter value was 16, the fractional word could be changed to 4/260, and the same resolution could be achieved.

### 2.3.2 DEN[21:12] and DEN[11:0]-- Fractional Denominator

These bits determine the fractional denominator. Note that the MSB bits for this word are in register R3. If the FDM bit is set to 0, DEN[21:12] are ignored. The fractional denominator should only be set to zero if the fractional circuitry is being disabled by setting ORDER=1. A value of one never makes sense to use. All other values could reasonably be used in fractional mode.

Fractional Denominator	DEN[21:12]										DEN[11:0]									
0	0	0	0	0	0	0	0	0	0	0	0	0	0	0	0	0	0	0	0	0
...																				
4095	1	1	1	1	1	1	1	1	1	1	1	1	1	1	1	1	1	1	1	1
4096	0	0	0	0	0	0	0	0	0	1	0	0	0	0	0	0	0	0	0	0
...																				
4194303	1	1	1	1	1	1	1	1	1	1	1	1	1	1	1	1	1	1	1	1



## 2.4 REGISTER R3

### 2.4.1 DEN[21:12] -- Extension for the Fractional Denominator

These are the MSB bits of the DEN word, which have already been discussed.

### 2.4.2 FoLD[3:0] -- Multiplexed Output for Ftest/LD Pin

The FoLD[3:0] word is used to program the output of the Ftest/LD Pin. This pin can be used for a general purpose I/O pin, a lock detect pin, and for diagnostic purposes. When programmed to the digital lock detect state, the output of the Ftest/LD pin will be high when the part is in lock, and low otherwise. Lock is determined by comparing the input phases to the phase detector. The analog lock detect modes put out a high signal with very fast negative pulses, that correspond to when the charge pump comes on. This output can be low pass filtered with an RC filter in order to determine the lock detect state. If the open drain state is used, a additional pull-up resistor is required. For diagnostic purposes, the options that allow one to view the output of the R counter or the N counter can be very useful. Be aware that the output voltage level of the Ftest/LD is not equal to the supply voltage of the part, but rather is given by  $V_{OH}$  and  $V_{OL}$  in the electrical characteristics specification.

FoLD	Output Type	Function
0	High Impedance	Disabled
1	Push-Pull	Logical High State
2	Push-Pull	Logical Low State
3	Push-Pull	Digital Lock Detect
4	N/A	Reserved
5	Push-Pull	N Counter Output Divided by 2
6	Open-Drain	Analog Lock Detect
7	Push-Pull	Analog Lock Detect
8	N/A	Reserved
9	N/A	Reserved
10	N/A	Reserved
11	N/A	Reserved
12	N/A	Reserved
13	N/A	Reserved
14	Push-Pull	R Counter Output
15	N/A	Reserved

### 2.4.3 ORDER -- Order of Delta Sigma Modulator

This bit determines the order of the delta sigma modulator in the PLL. In general, higher order fractional modulators tend to reduce the primary fractional spurs that occur at increments of the channel spacing, but can also create spurs that are at a fraction of the channel spacing, if there is not sufficient filtering. The optimal choice of modulator order is very application specific, however, a third order modulator is a good starting point if not sure what to try first.

ORDER	Delta Sigma Modulator Order
0	Fourth
1	Reset Modulator (Integer Mode - all fractions are ignored)
2	Second
3	Third

#### 2.4.4 DITHER -- Dithering

Dithering is useful in reducing fractional spurs, especially those that occur at a fraction of the channel spacing. The only exception is when the fractional numerator is zero. In this case, dithering usually is not a benefit. Dithering also can sometimes increase the PLL phase noise by a fraction of a dB. In general, if dithering is disabled, phase noise may be slightly better inside the loop bandwidth of the system, but spurs are likely to be worse too.

DITHER	Dithering Mode
0	Weak Dithering
1	Reserved
2	Strong Dithering
3	Dithering Disabled

#### 2.4.5 FDM -- Fractional Denominator Mode

When this bit is set to 1, the 10 MSB bits for the fractional numerator and denominator are considered. This allows the fractional denominator to range from 1 to 4,194,303. If this bit is set to zero, only the 12 LSB bits of the fractional numerator and denominator are considered, and this allows a fractional denominator from 1 to 4095. When this bit is disabled, the current consumption is about 0.5 mA lower.

#### 2.4.6 -- DIV2

When this bit is enabled, the output of the VCO is divided by 2. Enabling this bit does have some impact on harmonic content and output power.

DIV2	VCO Output Frequency
0	Not Divided by 2
1	Divided by 2

## 2.5 REGISTER R4

### 2.5.1 TOC[13:0] -- Time Out Counter for FastLock

When the value of this word is 3 or less, then FastLock is disabled, and this pin can only be used for general purpose I/O. When this value is 4 or greater, the time out counter is engaged for the amount of phase detector cycles shown in the table below.

TOC Value	FLout Pin State	Timeout Count
0	High Impedance	0
1	Low	Always Enabled
2	Low	0
3	High	0
4	Low	4 × 2 Phase Detector
.	.	.
16383	Low	16383 × 2 Phase Detector

When this count is active, the FLout Pin is grounded, the FastLock current is engaged, and the resistors R3 and R4 are also potentially changed. The table below summarizes the bits that control various values in and out of FastLock differences.

FastLock State	FLout	Charge Pump Current	R3	R4
Steady State	High Impedance	ICP	R3_ADJ	R4_ADJ
Fastlock	Grounded	ICPFL	R3_ADJ_FL	R4_ADJ_FL

### 2.5.2 ICPFL[3:0] -- Charge Pump Current for Fastlock

When FastLock is enabled, this is the charge pump current that is used for faster lock time.

ICPFL	Fastlock Charge Pump State	Typical Fastlock Charge Pump Current at 3 Volts (μA)
0	1X	90
1	2X	180
2	3X	270
3	4X	360
4	5X	450
5	6X	540
6	7X	630
7	8X	720
8	9X	810
9	10X	900
10	11X	990
11	12X	1080
12	13X	1170
13	14X	1260
14	15X	1350
15	16X	1440

## 2.6 REGISTER R5

### 2.6.1 EN\_PLL -- Enable Bit for PLL

When this bit is set to 1 (default), the PLL is powered up, otherwise, it is powered down.

### 2.6.2 EN\_VCO -- Enable Bit for the VCO

When this bit is set to 1 (default), the VCO is powered up, otherwise, it is powered down.

### 2.6.3 EN\_OSC -- Enable Bit for the Oscillator Inverter

When this bit is set to 1 (default), the reference oscillator is powered up, otherwise it is powered down.

### 2.6.4 EN\_VCOLDO -- Enable Bit for the VCO LDO

When this bit is set to 1 (default), the VCO LDO is powered up, otherwise it is powered down.

### 2.6.5 EN\_PLLLDO1 -- Enable Bit for the PLL LDO 1

When this bit is set to 1 (default), the PLL LDO 1 is powered up, otherwise it is powered down.

### 2.6.6 EN\_PLLLDO2 -- Enable Bit for the PLL LDO 2

When this bit is set to 1 (default), the PLL LDO 2 is powered up, otherwise it is powered down.

### 2.6.7 EN\_DIGLDO -- Enable Bit for the digital LDO

When this bit is set to 1 (default), the Digital LDO is powered up, otherwise it is powered down.

### 2.6.8 REG\_RST -- RESETS ALL REGISTERS TO DEFAULT SETTINGS

This bit needs to be programmed three times to initialize the part. When this bit is set to one, all registers are set to default mode, and the part is powered down. The second time the R5 register is programmed with REG\_RST=0, the register reset is released and the default states are still in the registers. However, since the default states for the blocks and LDOs is powered off, it is therefore necessary to program R5 a third time so that all the LDOs and blocks can be programmed to a power up state. When this bit is set to 1, all registers are set to the default modes, but part is powered down. For normal operation, this bit is set to 0. Note that once this initialization is done, it is not necessary to do this again unless power is removed from the device.

## 2.7 REGISTER R6

### 2.7.1 C3\_C4\_ADJ[2:0] -- VALUE FOR C3 AND C4 IN THE INTERNAL LOOP FILTER

C3_C4_ADJ	C3 (pF)	C4 (pF)
0	50	50
1	50	100
2	50	150
3	100	50
4	150	50
5	100	100
6	50	150
7	50	150

### 2.7.2 R3\_ADJ\_FL[1:0] -- Value for Internal Loop Filter Resistor R3 During Fastlock

R3_ADJ_FL Value	R3 Resistor During Fastlock (k $\Omega$ )
0	10
1	20
2	30
3	40

### 2.7.3 R3\_ADJ[1:0] -- Value for Internal Loop Filter Resistor R3

R3_ADJ	R3 Value (k $\Omega$ )
0	10
1	20
2	30
3	40

### 2.7.4 R4\_ADJ\_FL[1:0] -- Value for Internal Loop Filter Resistor R4 During Fastlock

R4_ADJ_FL	R4 Value during Fast Lock (k $\Omega$ )
0	10
1	20
2	30
3	40

### 2.7.5 R4\_ADJ[1:0] -- Value for Internal Loop Filter Resistor R4

R4_ADJ	R4 Value ( k $\Omega$ )
0	10
1	20
2	30
3	40

### 2.7.6 EN\_LPFLTR-- Enable for Partially Integrated Internal Loop Filter

The Enable Loop Filter bit is used to enable or disable the 3rd and 4th pole on-chip loop filters.

EN_LPFLTR	3rd and 4th Poles of Loop Filter
0	disabled (R3 = R4 = 0 $\Omega$ and C3 + C4 = 200pF)
1	enabled

### 2.7.7 VCO\_ACI\_SEL

This bit is used to optimize the VCO phase noise. The recommended values are what are used for all testing purposes, and this bit should be set as the table below instructs.

Part	VCO_ACI_SEL
All Other Options	8
LMX2531LQ2265E LMX2531LQ2570E LMX2531LQ2820E LMX2531LQ3010E	6

### 2.7.8 XTLSEL[2:0] -- Crystal Select

The XTLSEL bit is used to select between manual crystal mode and one of the automatic modes. The user may choose manual crystal mode (XTLSEL=4) and program the XTLMAN (R7[21:10]) and XTLMAN2 (R7[4]) bits for a specific OSCin frequency, or one of the automatic modes (XTLSEL = 0,1,2,3). For the LMX2531LQ2080E/2570E options or when the OSCin frequency is less than 8 MHz, manual crystal mode must always be selected. The automatic modes can be used for the other frequency options. When using one of the automatic modes, XTLSEL should be set based on the OSCin frequency.

XTLSEL	Mode	OSCin Frequency
0	<b>Automatic Modes</b> Programming of XTLMAN (R7[21:10]) not required. Programming of XTLMAN2 (R7[4]) not required.	8 - 25 MHz
1		25 - 50 MHz
2		50 - 70 MHz
3		70 - 80 MHz
4	<b>Manual Crystal Mode</b> Must use this for LMX2531LQ2080E/2570E/2820E/3010E Must use this if $f_{OSCin} < 8$ MHz Programming of XTLMAN (R7[21:10]) required. Programming of XTLMAN2 (R7[4]) may be required.	5 - 80 MHz
5,6,7	Reserved	

## 2.8 REGISTER R7

### 2.8.1 XTLDIV[1:0] -- Division Ratio for the Crystal Frequency

The frequency provided to the VCO frequency calibration circuitry is based on the OSCin frequency divided down by a factor, determined by the XTLDIV word. Note that this division ratio is independent of the R counter value or the phase detector frequency. The necessary division ratio depends on the OSCin frequency and is shown in the table below:

XTLDIV	Crystal Division Ratio	Crystal Range
0	Reserved	Reserved
1	Divide by 2	< 20 MHz
2	Divide by 4	20-40 MHz
3	Divide by 8	> 40 MHz

### 2.8.2 XTLMAN[11:0] -- Manual Crystal Mode

XTLMAN must be programmed if word XTLSSEL (2.7.8) is set to manual crystal mode. In the table below, the proper value for XTLMAN is shown based on some common OSCin frequencies ( $f_{\text{OSCin}}$ ) and various LMX2531 options. For any OSCin frequency XTLMAN can be calculated as  $16 \times f_{\text{OSCin}} / \text{Kbit}$ .  $f_{\text{OSCin}}$  is expressed in MHz and Kbit values for the LMX2531 frequency options can be found in the Kbit table (below).

XTLMAN Values for Common OSCin Frequencies						
Device	$f_{\text{OSCin}}$					
	5 MHz	10 MHz	20 MHz	30.72 MHz	61.44 MHz	76.8 MHz
LMX2531LQ1146E	53	107	213	327	655	819
LMX2531LQ1226E	53	107	213	327	655	819
LMX2531LQ1312E	47	94	188	289	578	722
LMX2531LQ1415E	47	94	188	289	578	722
LMX1531LQ1515E	40	80	160	246	492	614
LMX2531LQ1570E	38	76	152	234	468	585
LMX2531LQ1650E	38	76	152	234	468	585
LMX2531LQ1700E	35	70	139	214	427	534
LMX2531LQ1742	32	64	128	197	393	492
LMX2531LQ1778E	31	62	123	189	378	473
LMX2531LQ1910E	27	53	107	164	328	410
LMX2531LQ2265E	20	40	80	123	246	307
LMX2531LQ2080E	18	36	71	109	218	273
LMX2531LQ2570E	13	27	53	82	164	205
LMX2531LQ2820E	11	23	46	70	140	178
LMX2531LQ3010E	10	20	40	61	123	154

Kbit Values for Various LMX2531 options	
Device	Kbit
LMX2531LQ1146E	1.5
LMX2531LQ1226E	1.5
LMX2531LQ1312E	1.7
LMX2531LQ1415E	1.7
LMX2531LQ1515E	2
LMX2531LQ1570E	2.1
LMX2531LQ1650E	2.1
LMX2531LQ1700E	2.3
LMX25311742	2.5
LMX2531LQ1778E	2.6
LMX2531LQ1910E	3
LMX2531LQ2265E	4

Kbit Values for Various LMX2531 options	
Device	Kbit
LMX2531LQ2080E	4.5
LMX2531LQ2570E	6
LMX2531LQ2820E	7
LMX2531LQ3010E	8

## 2.9 REGISTER R8

### 2.9.1 XTLMAN2 -- MANUAL CRYSTAL MODE SECOND ADJUSTMENT

This bit also adjusts the calibration timing for lock time. In the case that manual mode for XTLSEL is selected and the OSCin frequency is greater than 40 MHz, this bit should be enabled, otherwise it should be 0.

### 2.9.2 LOCKMODE -- FREQUENCY CALIBRATION MODE

This bit controls the method for which the VCO frequency calibration is done. The two valid modes are linear mode and mixed mode. Linear mode works by searching through the VCO frequency bands in a consecutive manner. Mixed mode works by initially using a divide and conquer approach and then using a linear approach. For small frequency changes, linear mode is faster and for large frequency changes, mixed mode is faster. Linear mode can always be used, but there are restrictions for when Mixed Mode can be used.

LOCKMODE	Description	Conditions on Options	Conditions on OSCin Frequency
0	Reserved	Never use this mode	
1	Linear Mode	Works over all options and all valid OSCin Frequencies	
2	Mixed Mode	All but the following options LMX2531LQ1146E/1226E/1312E/1415E/1515E	$f_{\text{OSCin}} \geq 8 \text{ MHz}$
3	Reserved	Never use this mode	

## 2.10 REGISTER R9

All the bits in this register should be programmed as shown in the programming table.

## 2.11 REGISTER R12

Even though this register does not have user selectable bits, it still needs to be programmed. This register should be loaded as shown the Complete Register Content Map (section 2.03) .





Part	Marking	Package
LMX2531LQ1146E	311146E	LQA036D
LMX2531LQ1226E	311226E	LQA036D
LMX2531LQ1312E	311312E	LQA036D
LMX2531LQ1415E	311415E	LQA036D
LMX2531LQ1515E	311515E	LQA036D
LMX2531LQ1570E	311570EB	LQA036A
LMX2531LQ1650E	311650EA	LQA036A
LMX2531LQ1700E	311778EB	LQA036A

Part	Marking	Package
LMX2531LQ1742	311742EA	LQA036A
LMX2531LQ1778E	311778EA	LQA036A
LMX2531LQ1910E	311910EB	LQA036A
LMX2531LQ2080E	312080EB	LQA036A
LMX2531LQ2265E	312265ED	LQA036A
LMX2531LQ2570E	312570EC	LQA036A
LMX2531LQ2820E	312820E	LQA036D
LMX2531LQ3010E	313010E	LQA036D

# Notes

## Notes

For more National Semiconductor product information and proven design tools, visit the following Web sites at:

Products		Design Support	
Amplifiers	<a href="http://www.national.com/amplifiers">www.national.com/amplifiers</a>	WEBENCH® Tools	<a href="http://www.national.com/webench">www.national.com/webench</a>
Audio	<a href="http://www.national.com/audio">www.national.com/audio</a>	App Notes	<a href="http://www.national.com/appnotes">www.national.com/appnotes</a>
Clock and Timing	<a href="http://www.national.com/timing">www.national.com/timing</a>	Reference Designs	<a href="http://www.national.com/refdesigns">www.national.com/refdesigns</a>
Data Converters	<a href="http://www.national.com/adc">www.national.com/adc</a>	Samples	<a href="http://www.national.com/samples">www.national.com/samples</a>
Interface	<a href="http://www.national.com/interface">www.national.com/interface</a>	Eval Boards	<a href="http://www.national.com/evalboards">www.national.com/evalboards</a>
LVDS	<a href="http://www.national.com/lvds">www.national.com/lvds</a>	Packaging	<a href="http://www.national.com/packaging">www.national.com/packaging</a>
Power Management	<a href="http://www.national.com/power">www.national.com/power</a>	Green Compliance	<a href="http://www.national.com/quality/green">www.national.com/quality/green</a>
Switching Regulators	<a href="http://www.national.com/switchers">www.national.com/switchers</a>	Distributors	<a href="http://www.national.com/contacts">www.national.com/contacts</a>
LDOs	<a href="http://www.national.com/ldo">www.national.com/ldo</a>	Quality and Reliability	<a href="http://www.national.com/quality">www.national.com/quality</a>
LED Lighting	<a href="http://www.national.com/led">www.national.com/led</a>	Feedback/Support	<a href="http://www.national.com/feedback">www.national.com/feedback</a>
Voltage Reference	<a href="http://www.national.com/vref">www.national.com/vref</a>	Design Made Easy	<a href="http://www.national.com/easy">www.national.com/easy</a>
PowerWise® Solutions	<a href="http://www.national.com/powerwise">www.national.com/powerwise</a>	Solutions	<a href="http://www.national.com/solutions">www.national.com/solutions</a>
Serial Digital Interface (SDI)	<a href="http://www.national.com/sdi">www.national.com/sdi</a>	Mil/Aero	<a href="http://www.national.com/milaero">www.national.com/milaero</a>
Temperature Sensors	<a href="http://www.national.com/tempensors">www.national.com/tempensors</a>	SolarMagic™	<a href="http://www.national.com/solarmagic">www.national.com/solarmagic</a>
Wireless (PLL/VCO)	<a href="http://www.national.com/wireless">www.national.com/wireless</a>	PowerWise® Design University	<a href="http://www.national.com/training">www.national.com/training</a>

THE CONTENTS OF THIS DOCUMENT ARE PROVIDED IN CONNECTION WITH NATIONAL SEMICONDUCTOR CORPORATION ("NATIONAL") PRODUCTS. NATIONAL MAKES NO REPRESENTATIONS OR WARRANTIES WITH RESPECT TO THE ACCURACY OR COMPLETENESS OF THE CONTENTS OF THIS PUBLICATION AND RESERVES THE RIGHT TO MAKE CHANGES TO SPECIFICATIONS AND PRODUCT DESCRIPTIONS AT ANY TIME WITHOUT NOTICE. NO LICENSE, WHETHER EXPRESS, IMPLIED, ARISING BY ESTOPPEL OR OTHERWISE, TO ANY INTELLECTUAL PROPERTY RIGHTS IS GRANTED BY THIS DOCUMENT.

TESTING AND OTHER QUALITY CONTROLS ARE USED TO THE EXTENT NATIONAL DEEMS NECESSARY TO SUPPORT NATIONAL'S PRODUCT WARRANTY. EXCEPT WHERE MANDATED BY GOVERNMENT REQUIREMENTS, TESTING OF ALL PARAMETERS OF EACH PRODUCT IS NOT NECESSARILY PERFORMED. NATIONAL ASSUMES NO LIABILITY FOR APPLICATIONS ASSISTANCE OR BUYER PRODUCT DESIGN. BUYERS ARE RESPONSIBLE FOR THEIR PRODUCTS AND APPLICATIONS USING NATIONAL COMPONENTS. PRIOR TO USING OR DISTRIBUTING ANY PRODUCTS THAT INCLUDE NATIONAL COMPONENTS, BUYERS SHOULD PROVIDE ADEQUATE DESIGN, TESTING AND OPERATING SAFEGUARDS.

EXCEPT AS PROVIDED IN NATIONAL'S TERMS AND CONDITIONS OF SALE FOR SUCH PRODUCTS, NATIONAL ASSUMES NO LIABILITY WHATSOEVER, AND NATIONAL DISCLAIMS ANY EXPRESS OR IMPLIED WARRANTY RELATING TO THE SALE AND/OR USE OF NATIONAL PRODUCTS INCLUDING LIABILITY OR WARRANTIES RELATING TO FITNESS FOR A PARTICULAR PURPOSE, MERCHANTABILITY, OR INFRINGEMENT OF ANY PATENT, COPYRIGHT OR OTHER INTELLECTUAL PROPERTY RIGHT.

### LIFE SUPPORT POLICY

**NATIONAL'S PRODUCTS ARE NOT AUTHORIZED FOR USE AS CRITICAL COMPONENTS IN LIFE SUPPORT DEVICES OR SYSTEMS WITHOUT THE EXPRESS PRIOR WRITTEN APPROVAL OF THE CHIEF EXECUTIVE OFFICER AND GENERAL COUNSEL OF NATIONAL SEMICONDUCTOR CORPORATION.** As used herein:

Life support devices or systems are devices which (a) are intended for surgical implant into the body, or (b) support or sustain life and whose failure to perform when properly used in accordance with instructions for use provided in the labeling can be reasonably expected to result in a significant injury to the user. A critical component is any component in a life support device or system whose failure to perform can be reasonably expected to cause the failure of the life support device or system or to affect its safety or effectiveness.

National Semiconductor and the National Semiconductor logo are registered trademarks of National Semiconductor Corporation. All other brand or product names may be trademarks or registered trademarks of their respective holders.

Copyright© 2009 National Semiconductor Corporation

For the most current product information visit us at [www.national.com](http://www.national.com)



**National Semiconductor Americas Technical Support Center**  
 Email: [support@nsc.com](mailto:support@nsc.com)  
 Tel: 1-800-272-9959

**National Semiconductor Europe Technical Support Center**  
 Email: [europe.support@nsc.com](mailto:europe.support@nsc.com)

**National Semiconductor Asia Pacific Technical Support Center**  
 Email: [ap.support@nsc.com](mailto:ap.support@nsc.com)

**National Semiconductor Japan Technical Support Center**  
 Email: [jpn.feedback@nsc.com](mailto:jpn.feedback@nsc.com)