

High Speed Multi-phase PLL Clock Buffer

Features

- 500 ps max Total Timing Budget (TTB™) window
- 24 MHz –200 MHz input and Output Operation
- Low Output-output skew <200 ps
- 10 + 1 LVTTTL Outputs driving 50Ω terminated lines
- Dedicated feedback output
- Phase adjustments in 625ps/1300 ps steps up to +10.4 ns
- 3.3V LVTTTL/LVPECL, Fault Tolerant, and Hot Insertable Reference Inputs
- Multiply or Divide Ratios of 1 through 6, 8, 10, and 12
- Individual Output Bank Disable
- Output High Impedance Option for Testing Purposes
- Integrated Phase Locked Loop (PLL) with Lock Indicator
- Low Cycle-cycle jitter (<100 ps peak-peak)
- 3.3V Operation
- Industrial Temperature Range: –40°C to +85°C
- 52-pin 1.4 mm TQFP package

Functional Description

The CY7B9945V high speed multi-phase PLL clock buffer offers user selectable control over system clock functions. This multiple output clock driver provides the system integrator with functions necessary to optimize the timing of high performance computer and communication systems.

The device features a guaranteed maximum TTB window specifying all occurrences of output clocks. This includes the input reference clock across variations in output frequency, supply voltage, operating temperature, input edge rate, and process.

Ten configurable outputs each drive terminated transmission lines with impedances as low as 50Ω while delivering minimal and specified output skews at LVTTTL levels. The outputs are arranged in two banks of four and six outputs. These banks enable a divide function of 1 to 12, with phase adjustments in 625 ps–1300 ps increments up to ±10.4 ns. The dedicated feedback output enables divide-by functionality from 1 to 12 and limited phase adjustments. However, if needed, any one of the ten outputs can be connected to the feedback input as well as driving other inputs.

Selectable reference input is a fault tolerant feature that enables smooth change over to a secondary clock source when the primary clock source is not in operation. The reference inputs and feedback inputs are configurable to accommodate both LVTTTL or Differential (LVPECL) inputs. The completely integrated PLL reduces jitter and simplifies board layout.

Logic Block Diagram

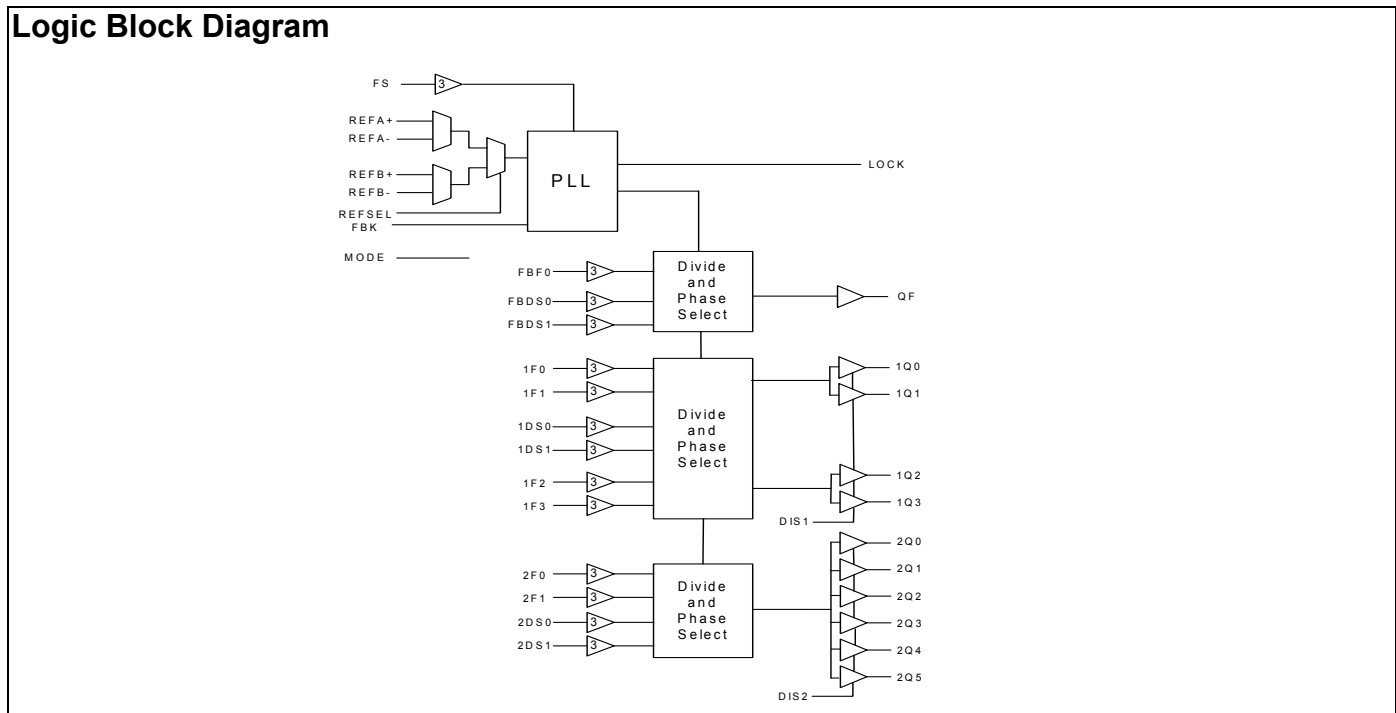

Contents

Features	1	Operating Range	8
Functional Description	1	Electrical Characteristics	
Contents	2	Over the Operating Range	8
Pinouts	3	Capacitance	9
Pin Definitions	3	Ordering Information	11
Block Diagram Description	4	Package Diagram	11
Time Unit Definition	4	Document History Page	12
Divide and Phase Select Matrix	4	Sales, Solutions, and Legal Information	13
Output Disable Description	6	Worldwide Sales and Design Support.....	13
Lock Detect Output Description.....	7	Products	13
Factory Test Mode Description	7	PSoC Solutions	13
Safe Operating Zone	7		
Absolute Maximum Conditions	8		

Pinouts

Figure 1. Pin Configuration

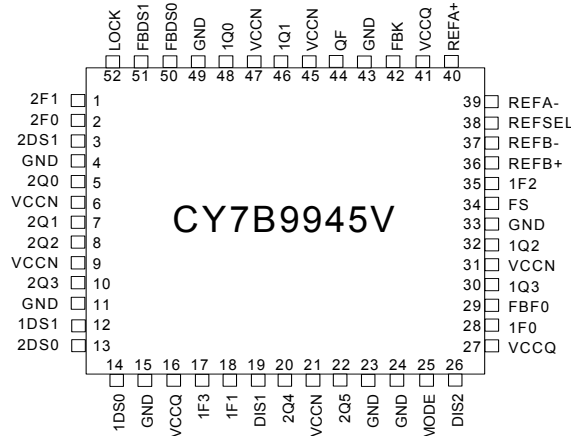

Pin Definitions

Pin	Name	IO	Type	Description
34	FS	Input	Three level Input	Frequency Select. This input must be set according to the nominal frequency (f_{NOM}). See Table 1 .
40,39, 36,37	REFA+, REFA-, REFB+, REFB-	Input	LVTTL/ LVDIFF	Reference Inputs. These inputs can operate as differential PECL or single-ended TTL reference inputs to the PLL. When operating as a single-ended LVTTL input, the complementary input is left open.
38	REFSEL	Input	LVTTL	Reference Select Input. The REFSEL input controls the configuration of reference input. When LOW, it uses the REFA pair as the reference input. When HIGH, it uses the REFB pair as the reference input. This input has an internal pull down.
42	FBK	Input	LVTTL	Feedback Input Clock. The PLL operates such that the rising edges of the reference and feedback signals are aligned in phase and frequency. This pin provides the clock output QF feedback to the phase detector.
28,18, 35,17, 2, 1	1F[0:3], 2F[0:1]	Input	Three level Input	Output Phase Function Select. Each pair determines the phase of the respective bank of outputs. See Table 3 .
19,26	DIS[1:2]	Input	LVTTL	Output Disable. Each input controls the state of the respective output bank. When HIGH, the output bank is disabled to HOLD-OFF or High-Z state; the disable state is determined by MODE. When LOW, outputs 1Q[0:3] and 2Q[0:5] are enabled. See Table 5 .
14,12, 13,3	[1:2]DS[0:1]	Input	Three level Input	Output Divider Function Select. Each pair determines the divider ratio of the respective bank of outputs. See Table 4 .
29	FBF0	Input	Three level Input	Feedback Output Phase Function Select. This input determines the phase of the QF output. See Table 3 .
50,51	FBDS[0:1]	Input	Three level Input	Feedback Output Divider Function Select. This input determines the divider ratio of the QF output. See Table 4 .
48,46, 32,30, 5,7,8,10, 20,22	1Q[0:3], 2Q[0:5]	Output	LVTTL	Clock Outputs with Adjustable Phases and f_{NOM} Divide Ratios. The output frequencies and phases are determined by [1:2]DS[0:1], and 1F[0:3] and 2F[0:1], respectively. See Table 3 and Table 4 .
44	QF	Output	LVTTL	Feedback Clock Output. This output is connected to the FBK input. The output frequency and phase are determined by FBDS[0:1] and FBF0, respectively. See Table 3 and Table 4 .
52	LOCK	Output	LVTTL	PLL Lock Indicator. When HIGH, this output indicates that the internal PLL is locked to the reference signal. When LOW, it indicates that the PLL is attempting to acquire lock

Pin Definitions

Pin	Name	IO	Type	Description
25	MODE	Input	Three level Input	This pin determines the clock outputs' disable state. When this input is HIGH, the clock outputs disables to high impedance state (High-Z). When this input is LOW, the clock outputs disables to HOLD-OFF mode. When in MID, the device enters factory test mode.
6,9,21, 31, 45, 47	VCCN		PWR	Power Supply for the Output Buffers
16,27, 41	VCCQ		PWR	Power Supply for the Internal Circuitry
4,11,15, 23,24, 33,43,49	GND		PWR	Device Ground

Block Diagram Description

The PLL adjusts the phase and the frequency of its output signal to minimize the delay between the reference (REFA/B+, REFA/B-) and the feedback (FB) input signals.

The CY7B9945V has a flexible REF input scheme. These inputs enable the use of either differential LVPECL or single ended LVTTTL inputs. To configure as single ended LVTTTL inputs, leave the complementary pin open (internally pulled to 1.5V), then the other input pin is used as a LVTTTL input. The REF inputs are also tolerant to hot insertion.

The REF inputs are changed dynamically. When changing from one reference input to the other reference input of the same frequency, the PLL is optimized to ensure that the clock outputs period is not less than the calculated system budget ($t_{MIN} = t_{REF} \text{ (nominal reference period)} - t_{CCJ} \text{ (cycle-cycle jitter)} - t_{PDEV} \text{ (max. period deviation)}$) while reacquiring lock.

The FS control pin setting determines the nominal operational frequency range of the divide by one output (f_{NOM}) of the device. f_{NOM} is directly related to the VCO frequency. The FS setting for the device is shown in Table 1. For CY7B9945V, the upper f_{NOM} range extends from 96 MHz to 200 MHz.

Table 1. Frequency Range Select

FS ^[1]	f_{NOM} (MHz)	
	Min	Max
LOW	24	52
MID	48	100
HIGH	96	200

Time Unit Definition

Selectable skew is in discrete increments of time unit (t_U). The value of a t_U is determined by the FS setting and the maximum nominal output frequency. The equation determines the t_U value as follows:

$$t_U = 1/(f_{NOM} * N).$$

N is a multiplication factor that is determined by the FS setting. f_{NOM} is nominal frequency of the device. N is defined in Table 2.

Table 2. N Factor Determination

FS	CY7B9945V	
	N	f_{NOM} (MHz) at which $t_U = 1.0 \text{ ns}$
LOW	32	31.25
MID	16	62.5
HIGH	8	125

Divide and Phase Select Matrix

The Divide Select Matrix is comprised of three independent banks: two of clock outputs and one for feedback. The Phase Select Matrix, enables independent phase adjustments on 1Q[0:1], 1Q[2:3] and 2Q[0:5]. The frequency of 1Q[0:3] is controlled by 1DS[0:1] while the frequency of 2Q[0:5] is controlled by 2DS[0:1]. The phase of 1Q[0:1] is controlled by 1F[0:1], that of 1Q[2:3] is controlled by 1F[2:3] and that of 2Q[0:5] is controlled by 2F[0:1].

The high fanout feedback output buffer (QF) connects to the feedback input (FBK). This feedback output has one phase function select input (FBF0) and two divider function selects FBDS[0:1].

The phase capabilities that are chosen by the phase function select pins are shown in Table 3. The divide capabilities for each bank are shown in Table 4.

Table 3. Output Phase Select

Control Signal		Output Phase Function			
1F1	1F0	1Q[0:1]			
1F3	1F2		1Q[2:3]		
2F1	2F0			2Q[0:5]	
	FBF0				QF
LOW	LOW	-4 t_U	-4 t_U	-8 t_U	-4 t_U
LOW	MID	-3 t_U	-3 t_U	-7 t_U	N/A
LOW	HIGH	-2 t_U	-2 t_U	-6 t_U	N/A
MID	LOW	-1 t_U	-1 t_U	BK1Q[0:1] ^[2]	N/A
MID	MID	0 t_U	0 t_U	0 t_U	0 t_U
MID	HIGH	+1 t_U	+1 t_U	BK1Q[2:3] ^[2]	N/A
HIGH	LOW	+2 t_U	+2 t_U	+6 t_U	N/A
HIGH	MID	+3 t_U	+3 t_U	+7 t_U	N/A
HIGH	HIGH	+4 t_U	+4 t_U	+8 t_U	+4 t_U

Table 4. Output Divider Select

Control Signal		Output Divider Function		
[1:2]DS1 and FBDS1	[1:2]DS0 and FBDS0	Bank1	Bank2	Feedback
LOW	LOW	/ 1	/ 1	/ 1
LOW	MID	/ 2	/ 2	/ 2
LOW	HIGH	/ 3	/ 3	/ 3

Table 4. Output Divider Select

Control Signal		Output Divider Function		
[1:2]DS1 and FBDS1	[1:2]DS0 and FBDS0	Bank1	Bank2	Feedback
MID	LOW	/ 4	/ 4	/ 4
MID	MID	/ 5	/ 5	/ 5
MID	HIGH	/ 6	/ 6	/ 6
HIGH	LOW	/ 8	/ 8	/ 8
HIGH	MID	/ 10	/ 10	/ 10
HIGH	HIGH	/ 12	/ 12	/ 12

Figure 2 shows the timing relationship of programmable skew outputs. All times are measured with respect to REF with the output used for feedback programmed with $0t_U$ skew. The PLL naturally aligns the rising edge of the FB input and REF input. If the output used for feedback is programmed to another skew position, then the whole t_U matrix shifts with respect to REF. For example, if the output used for feedback is programmed to shift $-4t_U$, then the whole matrix is shifted forward in time by $4t_U$. Thus an output programmed with $4t_U$ of skew gets effectively be skewed $8t_U$ with respect to REF.

Figure 2. Typical Outputs with FB Connected to a Zero-Skew Output^[3]

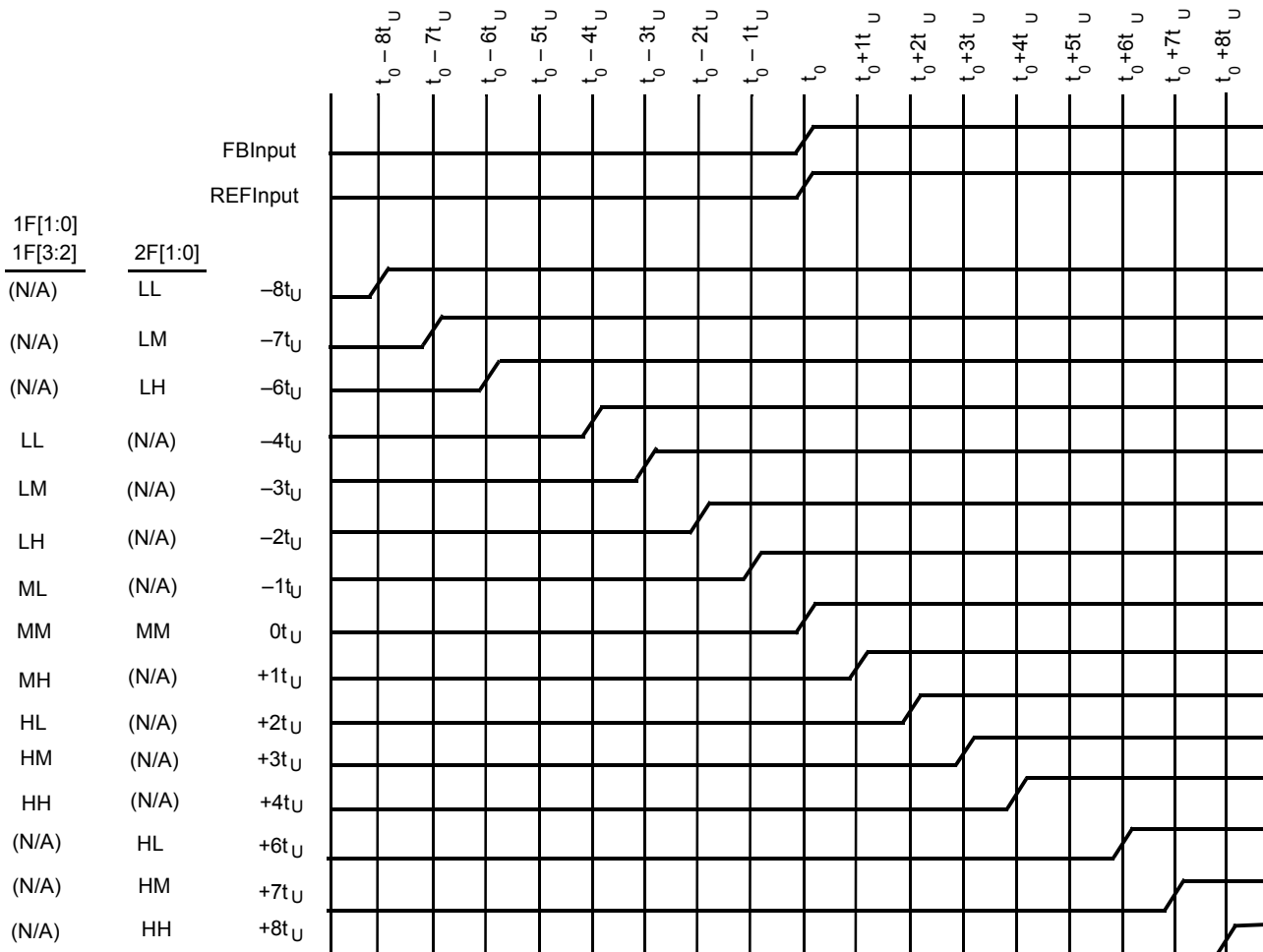

Output Disable Description

The output of each output bank can be independently put into a HOLD OFF or high impedance state. The combination of the MODE and DIS[1:2] inputs determines the clock outputs' state for each bank. When the DIS[1:2] is LOW, the outputs of the corresponding banks are enabled. When DIS[1:2] is HIGH, the outputs for that bank are disabled to a high impedance (HI-Z) or HOLD OFF state. Table 5 defines the disabled outputs functions.

The HOLD OFF state is a power saving feature. An output bank is disabled to the HOLD OFF state in a maximum of six output clock cycles from the time the disable input is HIGH. When disabled to the HOLD OFF state, outputs are driven to a logic LOW state on their falling edges. This makes certain that the

output clocks are stopped without a glitch. When a bank of outputs is disabled to HI-Z state, the respective bank of outputs go High-Z immediately.

Table 5. DIS[1:2] Functionality

MODE	DIS[1:2]	1Q[0:3], 2Q[0:5]
HIGH/LOW	LOW	ENABLED
HIGH	HIGH	HI-Z
LOW	HIGH	HOLD-OFF
MID	X	FACTORY TEST

Notes

1. FB connected to an output selected for "Zero" skew (i.e., FBF0 = MID or XF[1:0] = MID).
2. The level set on FS is determined by the "nominal" operating frequency (f_{NOM}) of the V_{CO} and Phase Generator. f_{NOM} always appears on an output when the output is operating in the undivided mode. The REF and FB are at f_{NOM} when the output connected to FB is undivided.
3. BK1Q denotes following the skew setting of indicated Bank1 outputs.
4. These inputs are normally wired to V_{CC} , GND, or left unconnected (actual threshold voltages vary as a percentage of V_{CC}). Internal termination resistors hold the unconnected inputs at $V_{CC}/2$. If these inputs are switched, the function and timing of the outputs may glitch and the PLL may require an additional t_{LOCK} time before all data sheet limits are achieved.
5. This is for non-three level inputs.

Lock Detect Output Description

The LOCK detect output indicates the lock condition of the integrated PLL. Lock detection is accomplished by comparing the phase difference between the reference and feedback inputs. Phase error is declared when the phase difference between the two inputs is greater than the specified device propagation delay limit t_{PD} .

When in the locked state, after four or more consecutive feedback clock cycles with phase errors, the LOCK output is forced LOW to indicate out-of-lock state.

When in the out-of-lock state, 32 consecutive phase errorless feedback clock cycles are required to enable the LOCK output to indicate lock condition (LOCK = HIGH).

If the feedback clock is removed after LOCK has gone HIGH, a "Watchdog" circuit is implemented to indicate the out-of-lock condition after a time-out period by deasserting LOCK LOW. This time out period is based upon a divided down reference clock.

This assumes that there is activity on the selected REF input. If there is no activity on the selected REF input then the LOCK detect pin does not accurately reflect the state of the internal PLL.

Factory Test Mode Description

The device enters factory test mode when the MODE is driven to MID. In factory test mode, the device operates with its internal PLL disconnected; input level supplied to the reference input is used in place of the PLL output. In TEST mode the FB input is tied LOW. All functions of the device remain operational in factory test mode except the internal PLL and output bank disables. The MODE input is designed as a static input. Dynamically toggling this input from LOW to HIGH temporarily causes the device to go into factory test mode (when passing through the MID state).

When in the test mode, the device is reset to a deterministic state by driving the DIS2 input HIGH. Doing so disables all outputs and, after the selected reference clock pin has five positive transitions, all internal finite state machines (FSM) are set at a deterministic state. The states depend on the configurations of

the divide, skew and frequency selection. All clock outputs stay in High-Z mode and all FSMs stay in the deterministic state until DIS2 is deasserted. This causes the device to reenter factory test mode.

Safe Operating Zone

Figure 3 shows the operating condition of the device not exceeding its allowable maximum junction temperature of 150°C. Figure 3 shows the maximum number of outputs that can operate at 185 MHz (with 25 pF load and no air flow) or 200 MHz (with 10-pF load and no air flow) at various ambient temperatures. At the limit line, all other outputs are configured to divide-by-two (i.e., operating at 92.5 MHz) or lower frequencies. The device operates below maximum allowable junction temperature of 150°C when its configuration (with the specified constraints) falls within the shaded region (safe operating zone). Figure 3 shows that at 85°C, the maximum number of outputs that can operate at 200 MHz is 6.

Figure 3. Typical Safe Operating Zone

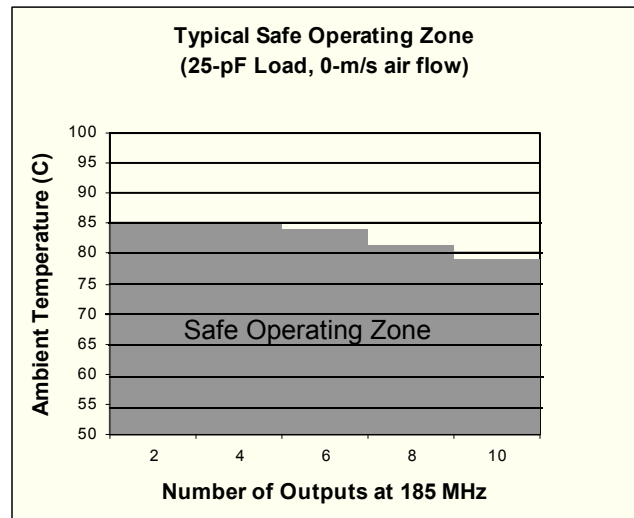

Absolute Maximum Conditions

Operating outside these boundaries may affect the performance and life of the device. These user guidelines are not tested.

- Storage Temperature -40°C to +125°C
- Ambient Temperature with Power Applied -40°C to +125°C
- Supply Voltage to Ground Potential.....-0.5V to +4.6V
- DC Input Voltage -0.3V to $V_{CC}+0.5V$
- Output Current into Outputs (LOW)..... 40 mA

Static Discharge Voltage..... > 1100V
(MIL-STD-883, Method 3015)

Latch Up Current > ± 200 mA

Operating Range

Range	Ambient Temperature	V_{CC}
Commercial	0°C to +70°C	3.3V ±10%
Industrial	-40°C to +85°C	3.3V ±10%

Electrical Characteristics Over the Operating Range

Description		Test Conditions	Min	Max	Unit
LVTTL HIGH Voltage	(QF, 1Q[0:3], 2Q[0:5])	$V_{CC} = \text{Min}, I_{OH} = -30 \text{ mA}$	2.4	-	V
	LOCK	$I_{OH} = -2 \text{ mA}, V_{CC} = \text{Min}$	2.4	-	V
LVTTL LOW Voltage	(QF, 1Q[0:3], 2Q[0:5])	$V_{CC} = \text{Min}, I_{OL} = 30 \text{ mA}$	-	0.5	V
	LOCK	$I_{OL} = 2 \text{ mA}, V_{CC} = \text{Min}$	-	0.5	V
High impedance State Leakage Current			-100	100	µA
LVTTL Input HIGH		$\text{Min} \leq V_{CC} \leq \text{Max}$	2.0	$V_{CC} + 0.3$	V
LVTTL Input LOW		$\text{Min.} \leq V_{CC} \leq \text{Max.}$	-0.3	0.8	V
LVTTL $V_{IN} > V_{CC}$		$V_{CC} = \text{GND}, V_{IN} = 3.63V$	-	100	µA
LVTTL Input HIGH Current		$V_{CC} = \text{Max}, V_{IN} = V_{CC}$	-	500	µA
LVTTL Input LOW Current		$V_{CC} = \text{Max}, V_{IN} = \text{GND}$	-500	-	µA
Three level Input HIGH ^[4]		$\text{Min} \leq V_{CC} \leq \text{Max}$	$0.87 * V_{CC}$	-	V
Three level Input MID ^[4]		$\text{Min} \leq V_{CC} \leq \text{Max}$	$0.47 * V_{CC}$	$0.53 * V_{CC}$	V
Three level Input LOW ^[4]		$\text{Min} \leq V_{CC} \leq \text{Max}$	-	$0.13 * V_{CC}$	V
Three level Input HIGH Current	FS[0:2],IF[0:3],FBDS[0:1]	$V_{IN} = V_{CC}$	-	200	µA
	2F[0:1],[1:2]DS[0:1],FBFO		-	400	µA
Three level Input MID Current	FS[0:2],IF[0:3],FBDS[0:1]	$V_{IN} = V_{CC}/2$	-50	50	µA
	2F[0:1],[1:2]DS[0:1],FBFO		-100	100	µA
Three level Input LOW Current	FS[0:2],IF[0:3],FBDS[0:1]	$V_{IN} = \text{GND}$	-200	-	µA
	2F[0:1],[1:2]DS[0:1],FBFO		-400	-	µA
Input Differential Voltage			400	V_{CC}	mV
Highest Input HIGH Voltage			1.0	V_{CC}	V
Lowest Input LOW Voltage			GND	$V_{CC} - 0.4$	V
Common Mode Range (Crossing Voltage)			0.8	$V_{CC} - 0.2$	V
Internal Operating Current	CY7B9945V	$V_{CC} = \text{Max}, f_{\text{MAX}}^{[5]}$	-	250	mA
Output Current Dissipation/Pair ^[4]	CY7B9945V	$V_{CC} = \text{Max}, C_{\text{LOAD}} = 25 \text{ pF}, R_{\text{LOAD}} = 50\Omega \text{ at } V_{CC}/2, f_{\text{MAX}}$	-	40	mA

Capacitance

Parameter	Description	Test Conditions	Min	Max	Unit
C _{IN}	Input Capacitance	T _A = 25°C, f = 1 MHz, V _{CC} = 3.3V	–	5	pF

Switching Characteristics

Over the Operating Range [5, 7, 8, 9, 10]

Parameter	Description	CY7B9945V-2		CY7B9945V-5		Unit
		Min	Max	Min	Max	
f _{in}	Clock Input Frequency	24	200	24	200	MHz
f _{out}	Clock Output Frequency	24	200	24	200	MHz
t _{SKEWPR}	Matched Pair Skew ^[12, 13] , 1Q[0:1], 1Q[2:3], 2Q[0:1], 2Q[2:3], 2Q[4:5]	–	200	–	200	ps
t _{SKEWBNK}	Intrabank Skew ^[12, 13]	–	250	–	250	ps
t _{SKEW0}	Output-Output Skew (same frequency and phase, rise to rise, fall to fall) ^[12, 13]	–	250	–	550	ps
t _{SKEW1}	Output-Output Skew (same frequency and phase, other banks at different frequency, rise to rise, fall to fall) ^[12, 13]	–	250	–	650	ps
t _{SKEW2}	Output-Output Skew (all output configurations outside of t _{SKEW0} and t _{SKEW1}) ^[10, 11]	–	500	–	800	ps
t _{CCJ1-3}	Cycle-to-Cycle Jitter (divide by 1 output frequency, FB = divide by 1, 2, 3)	–	150	–	150	ps Peak-Peak
t _{CCJ4-12}	Cycle-to-Cycle Jitter (divide by 1 output frequency, FB = divide by 4, 5, 6, 8, 10, 12)	–	100	–	100	ps Peak-Peak
t _{PD}	Propagation Delay, REF to FB Rise	–250	250	–500	500	ps
TTB	Total Timing Budget window (same frequency and phase) ^[14, 15]	–	500	–	700	ps
t _{PDELTA}	Propagation Delay difference between two devices ^[16]	–	200	–	200	ps
t _{REFpwh}	REF input (Pulse Width HIGH) ^[5]	2.0	–	2.0	–	ns
t _{REFpwl}	REF input (Pulse Width LOW) ^[5]	2.0	–	2.0	–	ns
t _r /t _f	Output Rise/Fall Time ^[17]	0.15	2.0	0.15	2.0	ns
t _{LOCK}	PLL Lock Time From Power Up	–	10	–	10	ms
t _{RELOCK1}	PLL Relock Time (from same frequency, different phase) with Stable Power Supply	–	500	–	500	μs
t _{RELOCK2}	PLL Re-lock Time (from different frequency, different phase) with Stable Power Supply ^[16]	–	1000	–	1000	μs
t _{ODCV}	Output duty cycle deviation from 50% ^[11]	–1.0	1.0	–1.0	1.0	ns
t _{PWH}	Output HIGH time deviation from 50% ^[19]	–	1.5	–	1.5	ns
t _{PWL}	Output LOW time deviation from 50% ^[19]	–	2.0	–	2.0	ns
t _{PDEV}	Period deviation when changing from reference to reference ^[20]	–	0.025	–	0.025	UI
t _{OAZ}	DIS[1:2] HIGH to output high-impedance from ACTIVE ^[12, 21]	1.0	10	1.0	10	ns
t _{OZA}	DIS[1:2] LOW to output ACTIVE from output is high impedance ^[21, 22]	0.5	14	0.5	14	ns

Notes

6. Assumes 25 pF Maximum Load Capacitance up to 185 MHz. At 200 MHz the maximum load is 10 pF.
7. Both outputs of pair must be terminated, even if only one is being used.
8. Each package must be properly decoupled.
9. AC parameters are measured at 1.5V, unless otherwise indicated.
10. Test Load C_L = 25 pF, terminated to V_{CC}/2 with 50Ω up to 185 MHz and 10 pF load to 200 MHz.
11. SKEW is defined as the time between the earliest and the latest output transition among all outputs for which the same phase delay has been selected when all outputs are loaded with 25 pF and properly terminated up to 185 MHz. At 200 MHz the max load is 10 pF.
12. Tested initially and after any design or process changes that affect these parameters.
13. TTB is the window between the earliest and the latest output clocks with respect to the input reference clock across variations in output frequency, supply voltage, operating temperature, input clock edge rate, and process. The measurements are taken with the AC test load specified and include output-output skew, cycle-cycle jitter, and dynamic phase error. TTB is equal to or smaller than the maximum specified value at a given output frequency.

Figure 4. AC Test Loads and Waveforms [22]

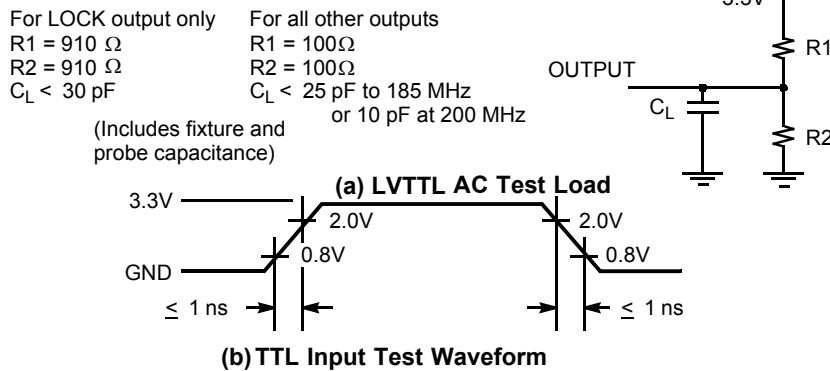
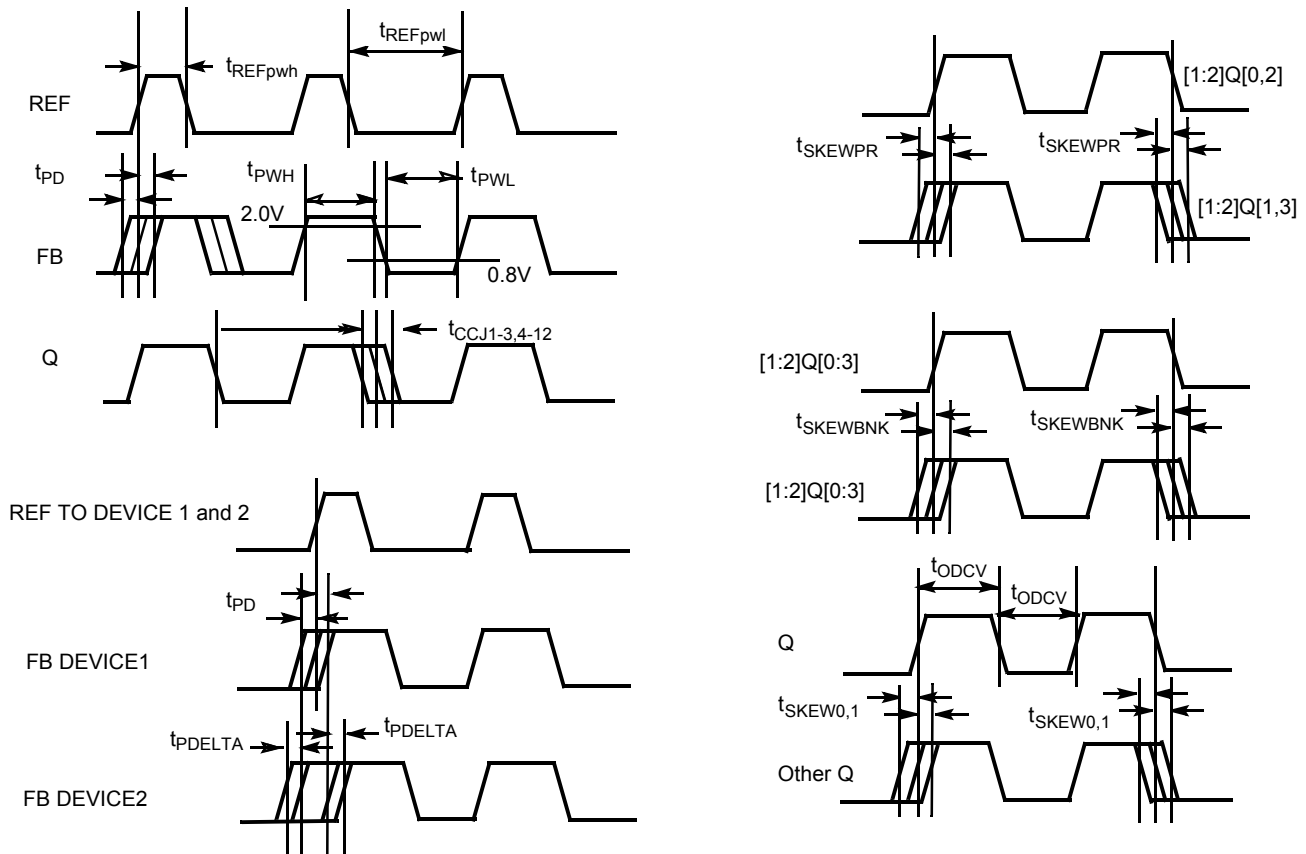

Figure 5. AC Timing Diagram



Notes

14. Guaranteed by statistical correlation. Tested initially and after any design or process changes that affects these parameters.
15. Rise and fall times are measured between 2.0V and 0.8V.
16. f_{NOM} must be within the frequency range defined by the same FS state.
17. t_{PWH} is measured at 2.0V. t_{PWL} is measured at 0.8V.
18. UI = unit interval. Examples: 1 UI is a full period. 0.1UI is 10% of period.
19. Measured at 0.5V deviation from starting voltage.
20. For t_{OZA} minimum, $C_L = 0$ pF. For t_{OZA} maximum, $C_L = 25$ pF to 185 MHz or 10 pF to 200 MHz
21. These figures are for illustration purposes only. The actual ATE loads may vary.

Ordering Information

Propagation Delay (ps)	Max. Speed (MHz)	Ordering Code	Package Name	Package Type	Operating Range
Pb-free					
250	200	CY7B9945V-2AXC	AZ52	52-pin TQFP	Commercial
	200	CY7B9945V-2AXCT	AZ52	52-pin TQFP – Tape and Reel	Commercial
250	200	CY7B9945V-2AXI	AZ52	52-pin TQFP	Industrial
	200	CY7B9945V-2AXIT	AZ52	52-pin TQFP – Tape and Reel	Industrial
500	200	CY7B9945V-5AXC	AZ52	52-pin TQFP	Commercial
	200	CY7B9945V-5AXCT	AZ52	52-pin TQFP – Tape and Reel	Commercial

Package Diagram

Figure 6. 52-Pin Thin Plastic Quad Flat Pack (10 x 10 x 1.4 mm) A52 and AZ52

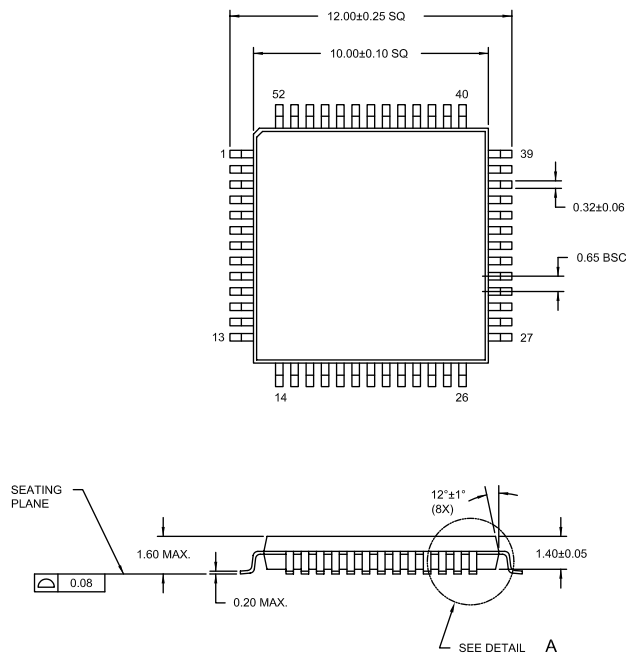

DIMENSIONS ARE IN MILLIMETERS

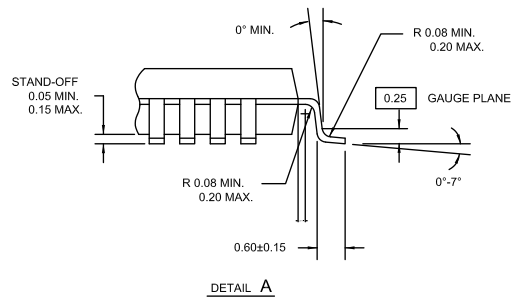

51-85131 *A

Document History Page

Document Title: CY7B9945V RoboClock® High Speed Multi-phase PLL Clock Buffer				
Document Number: 38-07336				
Revision	ECN	Orig. of Change	Submission Date	Description of Change
**	111747	CTK	03/04/02	New Data Sheet
*A	116572	HWT	09/05/02	Added TTB Features
*B	119078	HWT	10/16/02	Corrected the following items in the Electrical Characteristics table: I _{IIL} , I _{IHH} , I _{IIM} specifications from: three level input pins excluding FBFO to FS[0:2], IF[0:3], FBDS[0:1] and FBFO to 2F[0:1],[1:2]DS[0:1], FBFO Common Mode Range (V _{COM}) from V _{CC} to V _{CC} -0.2 Corrected typo TQFP to LQFP in Features
*C	124645	RGL	03/20/03	Corrected typo LQFP to TQFP in Features
*D	128464	RGL	07/25/03	Added clock input frequency (f _{in}) specifications in the switching characteristics table.
*E	272075	RGL	See ECN	Minor Change: Fixed the Typical Outputs (Fig. 1) diagram
*F	1187144	KVM	See ECN	Updated Ordering Information table, primarily to add Pb-free devices
*G	2761988	CXQ	09/10/09	Changed instances of "50W" to "50Ω" on page 1. Changed "Pb" to "lead" in Ordering Information package type section. Added "Not recommended for new designs" note to all Pb packages.
*H	2891379	KVM	03/12/2010	Added Table of Contents Updated Ordering Information table Updated Package Diagram Updated Sales, Solutions, and Legal Information

Sales, Solutions, and Legal Information

Worldwide Sales and Design Support

Cypress maintains a worldwide network of offices, solution centers, manufacturer's representatives, and distributors. To find the office closest to you, visit us at [Cypress Locations](#).

Products

Automotive	cypress.com/go/automotive
Clocks & Buffers	cypress.com/go/clocks
Interface	cypress.com/go/interface
Lighting & Power Control	cypress.com/go/powerpsoc
	cypress.com/go/plc
Memory	cypress.com/go/memory
Optical & Image Sensing	cypress.com/go/image
PSoC	cypress.com/go/psoc
Touch Sensing	cypress.com/go/touch
USB Controllers	cypress.com/go/USB
Wireless/RF	cypress.com/go/wireless

PSoC Solutions

psoc.cypress.com/solutions
PSoC 1 | PSoC 3 | PSoC 5

© Cypress Semiconductor Corporation, 2002-2010. The information contained herein is subject to change without notice. Cypress Semiconductor Corporation assumes no responsibility for the use of any circuitry other than circuitry embodied in a Cypress product. Nor does it convey or imply any license under patent or other rights. Cypress products are not warranted nor intended to be used for medical, life support, life saving, critical control or safety applications, unless pursuant to an express written agreement with Cypress. Furthermore, Cypress does not authorize its products for use as critical components in life-support systems where a malfunction or failure may reasonably be expected to result in significant injury to the user. The inclusion of Cypress products in life-support systems application implies that the manufacturer assumes all risk of such use and in doing so indemnifies Cypress against all charges.

Any Source Code (software and/or firmware) is owned by Cypress Semiconductor Corporation (Cypress) and is protected by and subject to worldwide patent protection (United States and foreign), United States copyright laws and international treaty provisions. Cypress hereby grants to licensee a personal, non-exclusive, non-transferable license to copy, use, modify, create derivative works of, and compile the Cypress Source Code and derivative works for the sole purpose of creating custom software and/or firmware in support of licensee product to be used only in conjunction with a Cypress integrated circuit as specified in the applicable agreement. Any reproduction, modification, translation, compilation, or representation of this Source Code except as specified above is prohibited without the express written permission of Cypress.

Disclaimer: CYPRESS MAKES NO WARRANTY OF ANY KIND, EXPRESS OR IMPLIED, WITH REGARD TO THIS MATERIAL, INCLUDING, BUT NOT LIMITED TO, THE IMPLIED WARRANTIES OF MERCHANTABILITY AND FITNESS FOR A PARTICULAR PURPOSE. Cypress reserves the right to make changes without further notice to the materials described herein. Cypress does not assume any liability arising out of the application or use of any product or circuit described herein. Cypress does not authorize its products for use as critical components in life-support systems where a malfunction or failure may reasonably be expected to result in significant injury to the user. The inclusion of Cypress' product in a life-support systems application implies that the manufacturer assumes all risk of such use and in doing so indemnifies Cypress against all charges.

Use may be limited by and subject to the applicable Cypress software license agreement.