

## Features

- High Frequency >150 MHz
- High-speed, low-noise, non-inverting clock buffer
  - PI49FCT20802 is a 1:5 buffer
  - PI49FCT20803 is a 1:7 buffer
- Low skew < 150ps
- Low duty cycle distortion < 300ps
- Low propagation delay < 3.5ns
- Multiple V<sub>DD</sub>, GND pins for noise reduction
- 2.5V supply voltage and 3V tolerant input
- Packages (Pb-Free & Green):
  - 16-pin TSSOP (L)
  - 16-pin QSOP (Q)

## Description

The PI49FCT2080x is 2.5V, high-speed, low noise, non-inverting clock buffer. It is designed to target networking applications that require low-skew, low-jitter, and high-frequency clock distribution. It provides output-to-output skew as low as 150ps, and is an ideal clock distribution device for synchronous systems. PI49FCT2080x is a clock buffer from a single input that produces five outputs on PI49FCT20802 and seven outputs on PI49FCT20803. PI49FCT2080x is characterized for operation from -40°C to 85°C.

### Pin Configuration (PI49FCT20802)

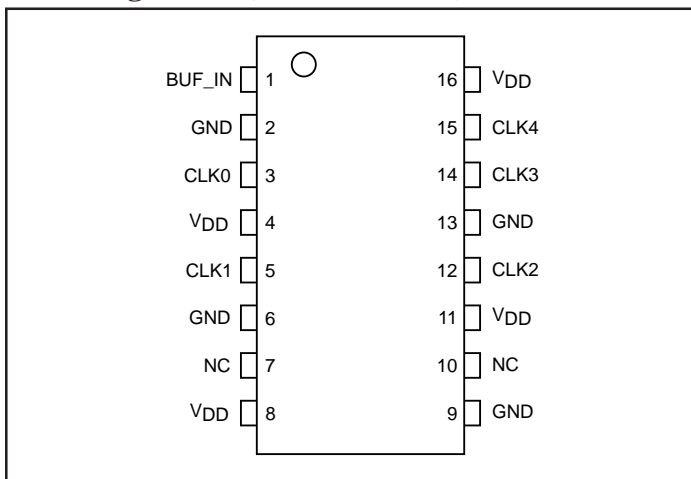

### Block Diagram (PI49FCT20802)

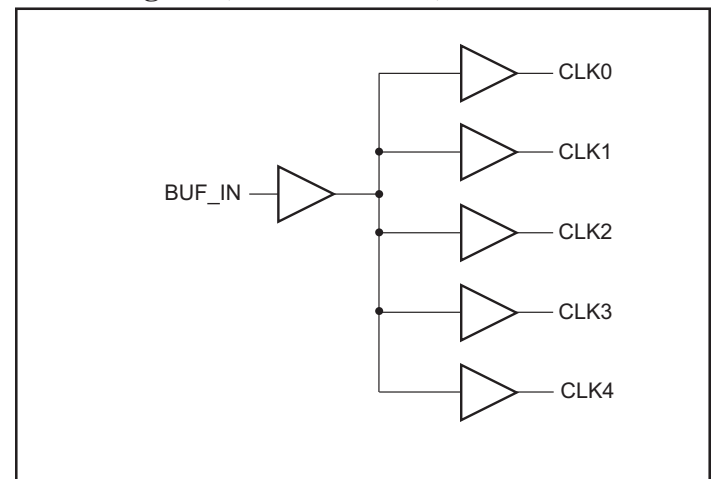

### Pin Configuration (PI49FCT20803)

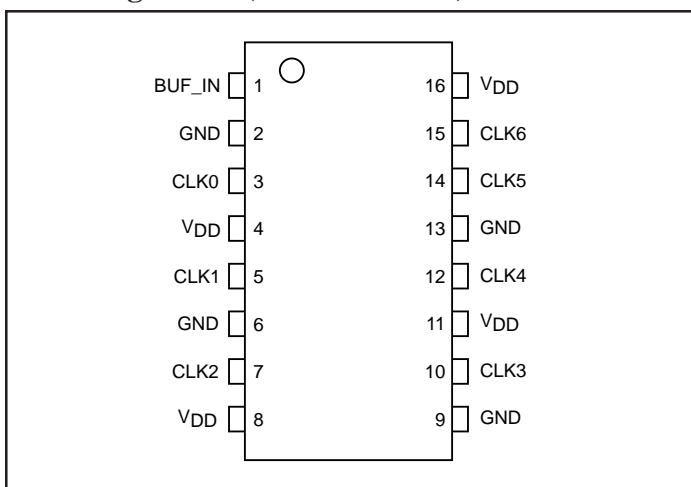

### Block Diagram (PI49FCT20803)

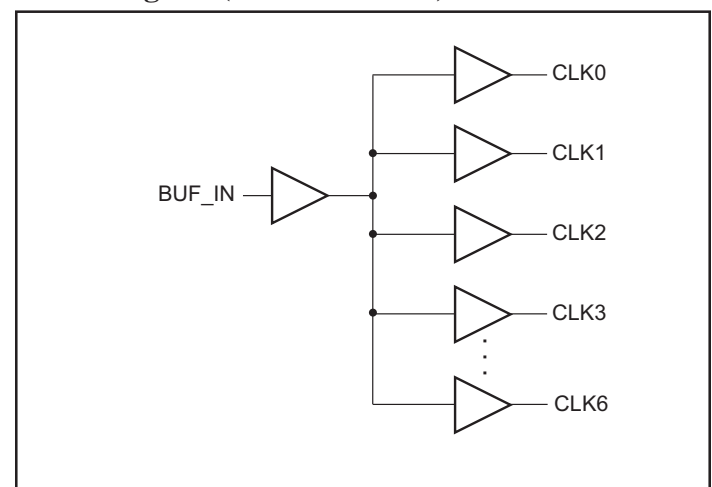

### Maximum Ratings

(Above which the useful life may be impaired. For user guidelines, not tested.)

Storage Temperature .....	-65°C to +150°C
Supply Voltage $V_{DD}$ .....	-0.5V to +3.6V
Input/Output Voltages <sup>(1)</sup> .....	-0.5V to $V_{DD}+0.5V$
DC Output Current .....	-60mA to +60mA
Power Dissipation .....	500mW

**Note:**

Stresses greater than those listed under MAXIMUM RATINGS may cause permanent damage to the device. This is a stress rating only and functional operation of the device at these or any other conditions above those indicated in the operational sections of this specification is not implied. Exposure to absolute maximum rating conditions for extended periods may affect reliability.

### Operating Range

$V_{DD}$ Voltage .....	2.5V ± 0.2V
Industrial Temperature .....	-40°C to +85°C
Commercial Temperature .....	0°C to +70°C
Capacitive Loading .....	10pF to 25pF

### DC Electrical Characteristics (Over the Operating Range)

Parameters	Description	Test Conditions <sup>(2)</sup>	Min.	Typ. <sup>(3)</sup>	Max.	Units
$V_{IH}$	Input HIGH Voltage		1.7			V
$V_{IL}$	Input LOW Voltage				0.7	
$I_I$	Input Current	$V_{DD} = 0$ or $V_{DD}$			±1	mA
$V_{IK}$	Clamp Diode Voltage	$V_{DD} = \text{Min.}, I_{IN} = -18\text{mA}$		-0.7	-1	V
$V_{OH}$	Output HIGH Voltage	$V_{DD} = \text{Min.}$	$I_{OH} = -1\text{mA}$	2		
			$I_{OH} = -8\text{mA}$	1.8 <sup>(3)</sup>		
$V_{OL}$	Output LOW Voltage	$V_{DD} = \text{Min.}$	$I_{OL} = 1\text{mA}$		0.4	
			$I_{OL} = 8\text{mA}$		0.6	

**Notes:**

1. This value is limited to 3.6V maximum.
2. For Max. or Min. conditions, use appropriate value specified under Electrical Characteristics for the applicable device type.
3. Typical values are at  $V_{DD} = 2.5V$ , +25°C ambient and maximum loading.

### Power Supply Characteristics

Parameters	Description	Test Conditions <sup>(4)</sup>	Min.	Typ. <sup>(5)</sup>	Max.	Units
$I_{DDQ}$	Quiescent Power Supply Current	$V_{IN} = 0$ or $V_{DD}$		0.1	20	$\mu A$
$\Delta I_{DD}$	Supply Current per Inputs	$V_{IN} = V_{DD} - 0.6V$ <sup>(6)</sup>		47	300	
$I_{DD}$	Dynamic Supply Current (See Graph 1)	$V_{DD} = 2.7V$ , 15pF & 33-ohm load, $f = 150$ MHz		136		mA

**Notes:**

4. For Max. or Min. conditions, use appropriate value specified under Electrical Characteristics for the applicable device.
5. Typical values are at  $V_{DD} = 2.5V$ ,  $+25^{\circ}C$  ambient and maximum loading.
6. Per TTL driven input ( $V_{IN} = V_{DD} - 0.6V$ ); all other inputs at  $V_{DD}$  or GND.

**Graph 1. Dynamic Current vs. Clock Frequency**

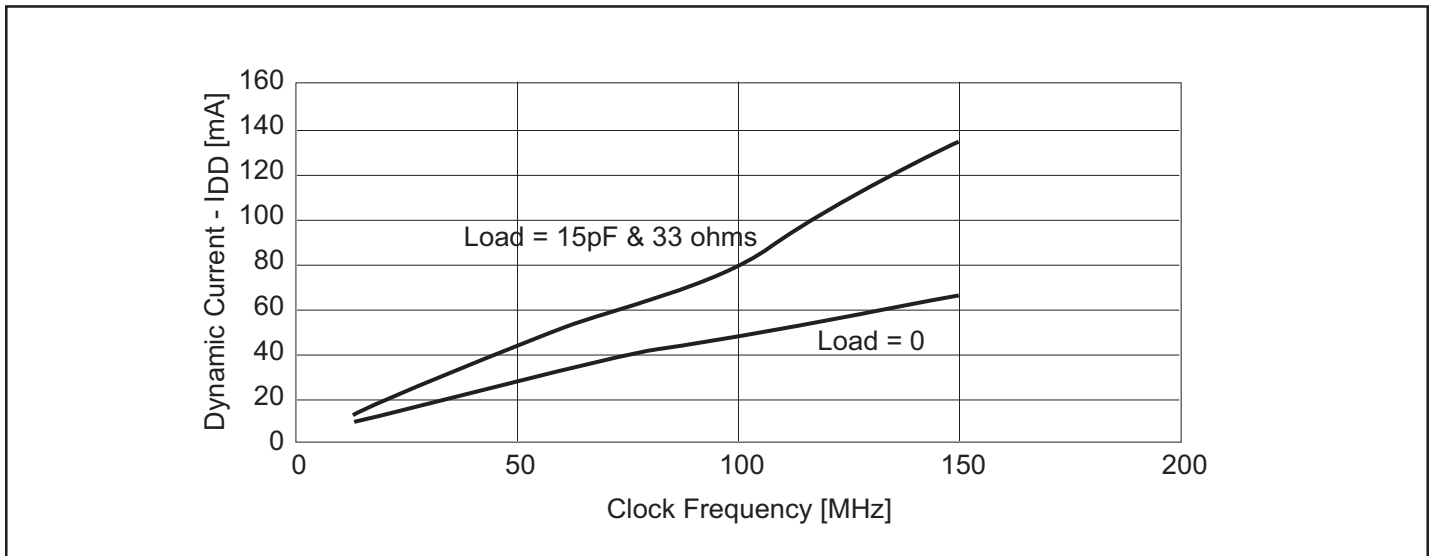

**Capacitance** ( $T_A = 25^{\circ}C$ ,  $f = 1$  MHz)

Parameters	Description	Test Conditions	Typ <sup>(7)</sup>	Max.	Units
$C_{IN}$	Input Capacitance	$V_{IN} = 0V$	3	4	pF
$C_{OUT}$	Output Capacitance	$V_{OUT} = 0V$		6	

**Note:**

7. This parameter is determined by device characterization but is not production tested.

**Switching Characteristics** ( $V_{DD}=2.5V\pm 0.2V$ ,  $T_A=85^\circ C$ )

Parameters	Description	Test Conditions <sup>(8)</sup>	Min.	Typ.	Max.	Units
$f_{CLK}$	Output Frequency				150	MHz
$t_R/t_F$	Rise/Fall time $V_O = 0.7V \sim 1.7V$	$C_L = 22pF, 100MHz$		1.0	1.25	ns
		$C_L = 12pF, 150MHz$		1.0	1.2	
$t_{PD}$	Propagation Delay	$C_L = 22pF, 100MHz$		3.5	3.5	ns
		$C_L = 12pF, 150MHz$		2.4	2.7	
$t_{SK(o)}$	Output Skew	$C_L = 22pF, 100MHz$		100	150	ps
		$C_L = 12pF, 150MHz$		100	150	
$t_{SK(p)}$	Pulse Skew	$C_L = 22pF, 100MHz$		250	300	ps
		$C_L = 12pF, 150MHz$		250	300	
$t_{SK(d)}$	Device-to-device skew <sup>(9)</sup>	$C_L = 12pF, 150MHz$		400	600	

**Notes:**

8. See test circuit and waveforms.
9. Identical conditions: loading, transitions, supply voltage, temperature, package type and speed grade.

**Product Pin Description**

Pin Name		Description
PI49FCT20802	PI49FCT20803	
BUF_IN	BUF_IN	Input
CLK [0:4]	CLK [0:6]	Outputs
GND	GND	GND
$V_{DD}$	$V_{DD}$	Power

**Test Circuits for All Outputs**

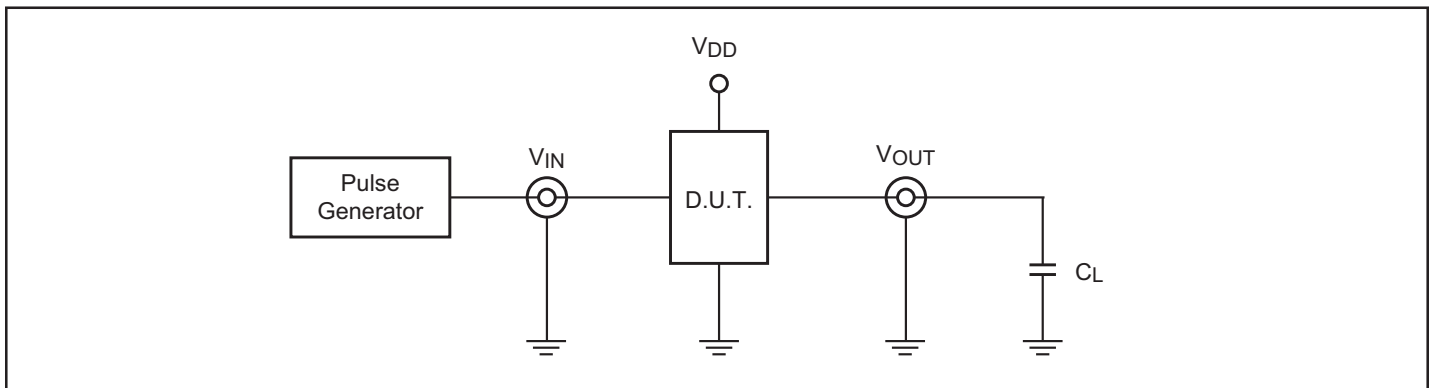

### Switching Waveforms

#### Propagation Delay

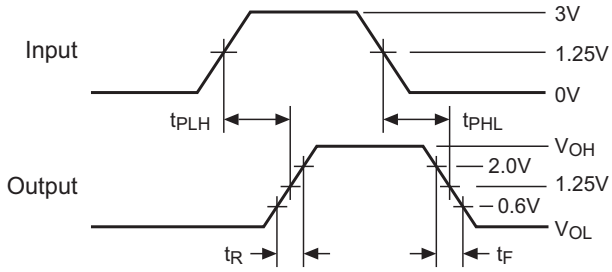

#### Pulse Skew – $t_{SK(P)}$

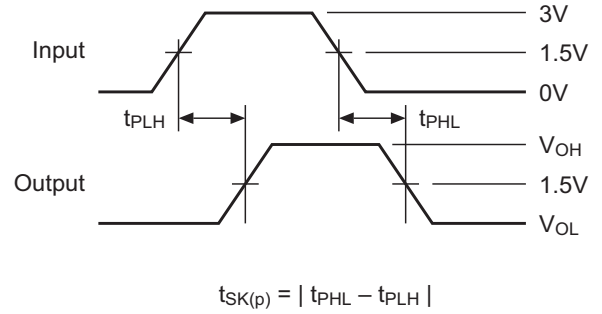

#### Output Skew – $t_{SK(O)}$

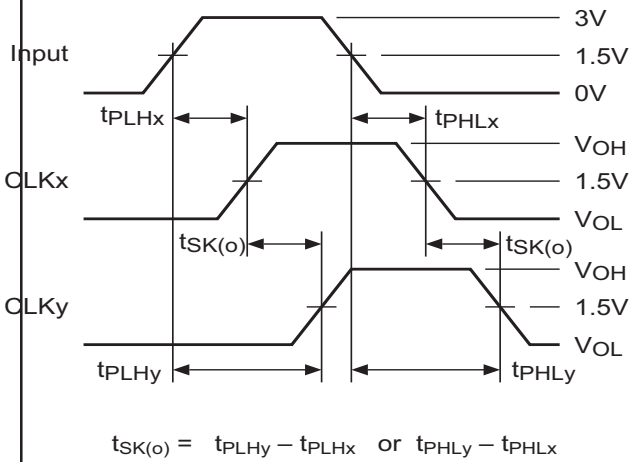

#### Package Skew – $t_{SK(T)}$

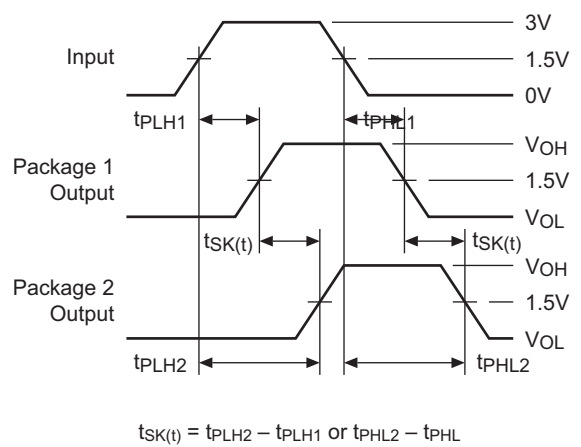

Packaging Mechanical: 16-Pin TSSOP (L)

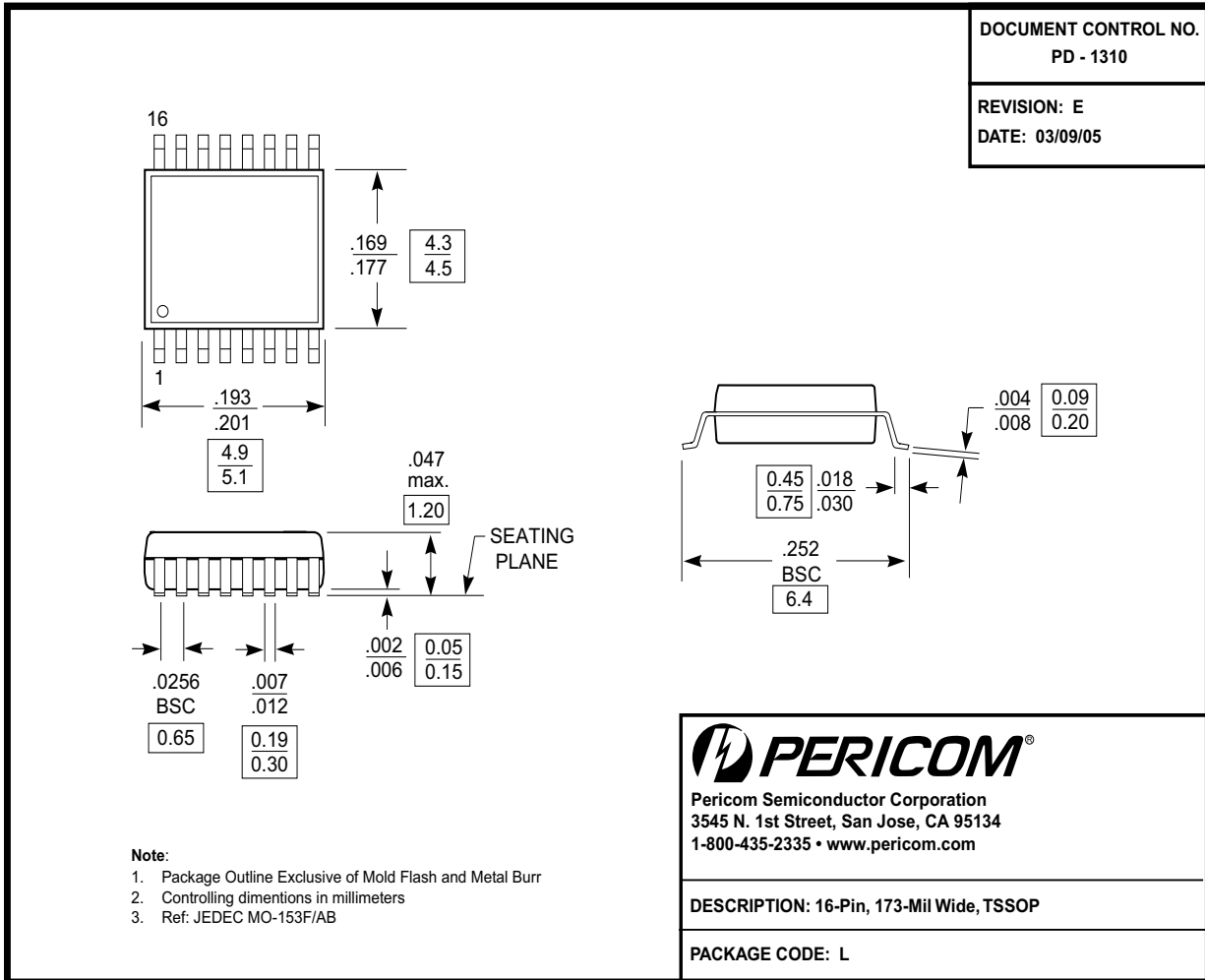

Packaging Mechanical: 16-Pin QSOP (Q)

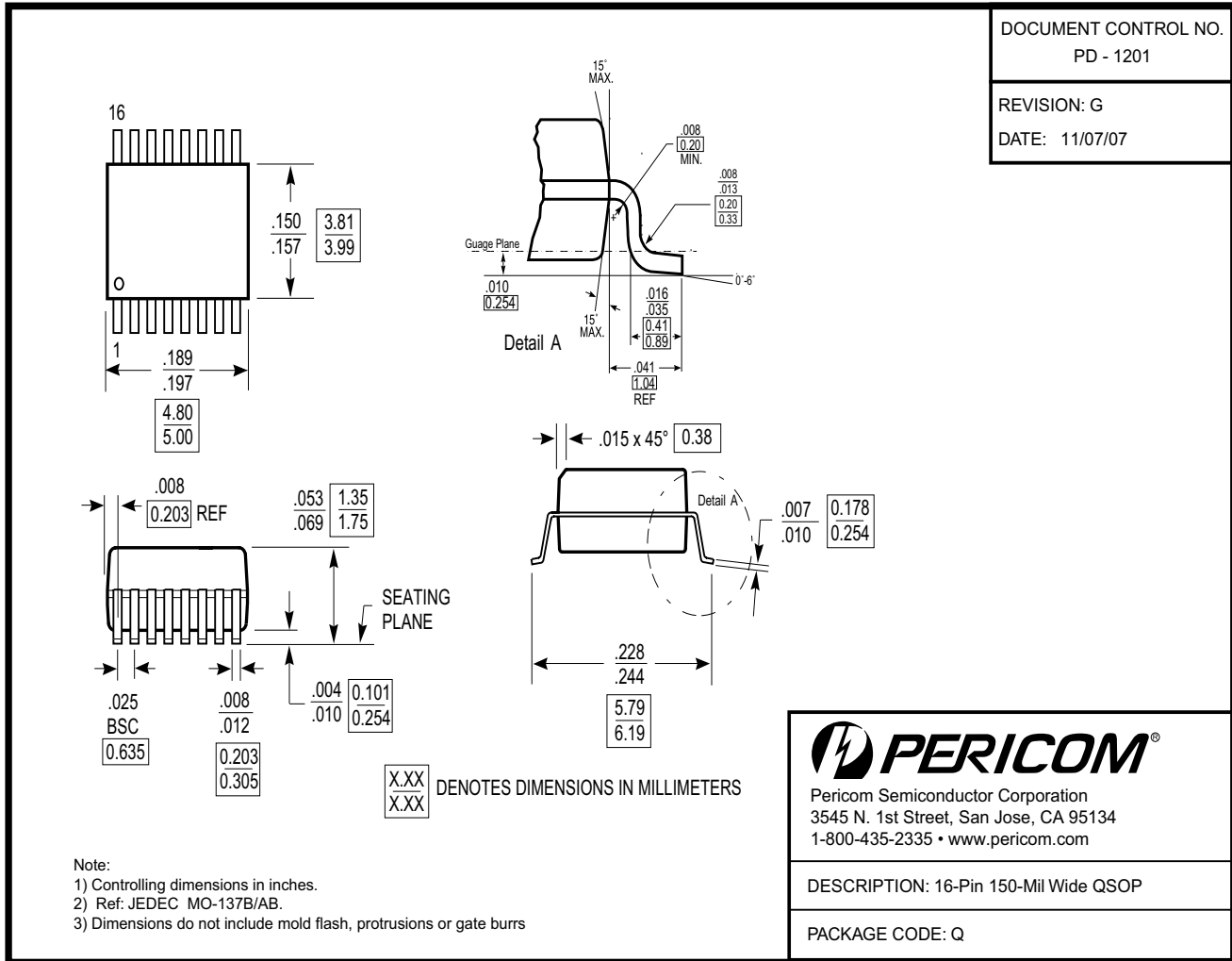

Ordering Information

Ordering Code	Package Code	Package Description
PI49FCT20802QE	Q	Pb-free & Green, 16-pin 150-mil wide QSOP
PI49FCT20802LE	L	Pb-free & Green, 16-pin 173-mil wide TSSOP
PI49FCT20803QE	Q	Pb-free & Green, 16-pin 150-mil wide QSOP
PI49FCT20803LE	L	Pb-free & Green, 16-pin 173-mil wide TSSOP

Notes:

- Thermal characteristics can be found on the company web site at [www.pericom.com/packaging/](http://www.pericom.com/packaging/)