



CYPRESS

CY7B991V 3.3V RoboClock

Low Voltage Programmable Skew Clock Buffer

Features

- All output pair skew <100 ps typical (250 max.)
- 3.75- to 80-MHz output operation
- User-selectable output functions
 - Selectable skew to 18 ns
 - Inverted and non-inverted
 - Operation at $\frac{1}{2}$ and $\frac{1}{4}$ input frequency
 - Operation at 2x and 4x input frequency (input as low as 3.75 MHz)
- Zero input to output delay
- 50% duty-cycle outputs
- LVTTTL Outputs drive 50Ω terminated lines
- Operates from a single 3.3V supply
- Low operating current
- 32-pin PLCC package
- Jitter < 200 ps peak-to-peak (< 25 ps RMS)

Functional Description

The CY7B991V Low Voltage Programmable Skew Clock Buffer (LVPSCB) offers user-selectable control over system clock

functions. These multiple-output clock drivers provide the system integrator with functions necessary to optimize the timing of high-performance computer systems. Eight individual drivers, arranged as four pairs of user-controllable outputs, can each drive terminated transmission lines with impedances as low as 50Ω while delivering minimal and specified output skews and full-swing logic levels (LVTTTL).

Each output can be hardwired to one of nine delay or function configurations. Delay increments of 0.7 to 1.5 ns are determined by the operating frequency with outputs able to skew up to ±6 time units from their nominal “zero” skew position. The completely integrated PLL allows external load and transmission line delay effects to be canceled. When this “zero delay” capability of the LVPSCB is combined with the selectable output skew functions, the user can create output-to-output delays of up to ±12 time units.

Divide-by-two and divide-by-four output functions are provided for additional flexibility in designing complex clock systems. When combined with the internal PLL, these divide functions allow distribution of a low-frequency clock that can be multiplied by two or four at the clock destination. This facility minimizes clock distribution difficulty while allowing maximum system clock speed and flexibility.

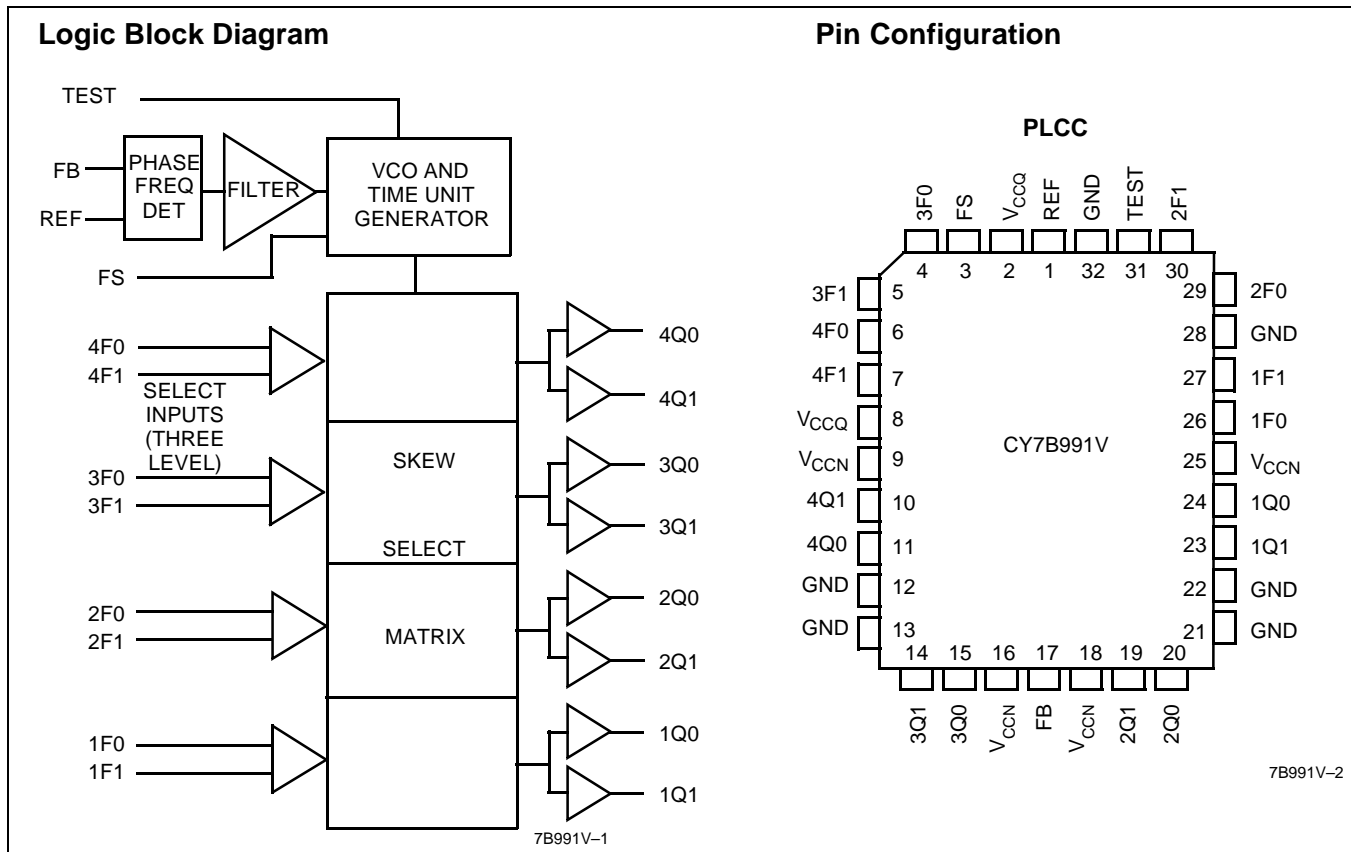

Pin Definitions

| Signal Name | I/O | Description |
|------------------|-----|---|
| REF | I | Reference frequency input. This input supplies the frequency and timing against which all functional variation is measured. |
| FB | I | PLL feedback input (typically connected to one of the eight outputs). |
| FS | I | Three-level frequency range select. See <i>Table 1</i> . |
| 1F0, 1F1 | I | Three-level function select inputs for output pair 1 (1Q0, 1Q1). See <i>Table 2</i> |
| 2F0, 2F1 | I | Three-level function select inputs for output pair 2 (2Q0, 2Q1). See <i>Table 2</i> |
| 3F0, 3F1 | I | Three-level function select inputs for output pair 3 (3Q0, 3Q1). See <i>Table 2</i> |
| 4F0, 4F1 | I | Three-level function select inputs for output pair 4 (4Q0, 4Q1). See <i>Table 2</i> |
| TEST | I | Three-level select. See test mode section under the block diagram descriptions. |
| 1Q0, 1Q1 | O | Output pair 1. See <i>Table 2</i> |
| 2Q0, 2Q1 | O | Output pair 2. See <i>Table 2</i> |
| 3Q0, 3Q1 | O | Output pair 3. See <i>Table 2</i> |
| 4Q0, 4Q1 | O | Output pair 4. See <i>Table 2</i> |
| V _{CCN} | PWR | Power supply for output drivers. |
| V _{CCQ} | PWR | Power supply for internal circuitry. |
| GND | PWR | Ground. |

Block Diagram Description

Phase Frequency Detector and Filter

These two blocks accept inputs from the reference frequency (REF) input and the feedback (FB) input and generate correction information to control the frequency of the Voltage-Controlled Oscillator (VCO). These blocks, along with the VCO, form a Phase-Locked Loop (PLL) that tracks the incoming REF signal.

VCO and Time Unit Generator

The VCO accepts analog control inputs from the PLL filter block and generates a frequency that is used by the time unit generator to create discrete time units that are selected in the skew select matrix. The operational range of the VCO is determined by the FS control pin. The time unit (t_U) is determined by the operating frequency of the device and the level of the FS pin as shown in *Table 1*.

Table 1. Frequency Range Select and t_U Calculation^[1]

| FS ^[2, 3] | f_{NOM} (MHz) | | $t_U = \frac{1}{f_{NOM} \times N}$ where N = | Approximate Frequency (MHz) At Which $t_U = 1.0$ ns |
|----------------------|-----------------|------|---|---|
| | Min. | Max. | | |
| LOW | 15 | 30 | 44 | 22.7 |
| MID | 25 | 50 | 26 | 38.5 |
| HIGH | 40 | 80 | 16 | 62.5 |

Notes:

- For all three-state inputs, HIGH indicates a connection to V_{CC}, LOW indicates a connection to GND, and MID indicates an open connection. Internal termination circuitry holds an unconnected input to V_{CC}/2.
- The level to be set on FS is determined by the "normal" operating frequency (f_{NOM}) of the VCO and Time Unit Generator (see Logic Block Diagram). Nominal frequency (f_{NOM}) always appears at 1Q0 and the other outputs when they are operated in their undivided modes (see *Table 2*). The frequency appearing at the REF and FB inputs will be f_{NOM} when the output connected to FB is undivided. The frequency of the REF and FB inputs will be $f_{NOM}/2$ or $f_{NOM}/4$ when the part is configured for a frequency multiplication by using a divided output as the FB input.
- When the FS pin is selected HIGH, the REF input must not transition upon power-up until V_{CC} has reached 2.8V.

Skew Select Matrix

The skew select matrix is comprised of four independent sections. Each section has two low-skew, high-fanout drivers (xQ0, xQ1), and two corresponding three-level function select (xF0, xF1) inputs. *Table 2* below shows the nine possible output functions for each section as determined by the function select inputs. All times are measured with respect to the REF input assuming that the output connected to the FB input has 0 t_U selected.

Table 2. Programmable Skew Configurations^[1]

| Function Selects | | Output Functions | | |
|--------------------|--------------------|--------------------|-------------|-------------|
| 1F1, 2F1, 3F1, 4F1 | 1F0, 2F0, 3F0, 4F0 | 1Q0, 1Q1, 2Q0, 2Q1 | 3Q0, 3Q1 | 4Q0, 4Q1 |
| LOW | LOW | -4 t_U | Divide by 2 | Divide by 2 |
| LOW | MID | -3 t_U | -6 t_U | -6 t_U |
| LOW | HIGH | -2 t_U | -4 t_U | -4 t_U |
| MID | LOW | -1 t_U | -2 t_U | -2 t_U |
| MID | MID | 0 t_U | 0 t_U | 0 t_U |
| MID | HIGH | +1 t_U | +2 t_U | +2 t_U |
| HIGH | LOW | +2 t_U | +4 t_U | +4 t_U |
| HIGH | MID | +3 t_U | +6 t_U | +6 t_U |
| HIGH | HIGH | +4 t_U | Divide by 4 | Inverted |

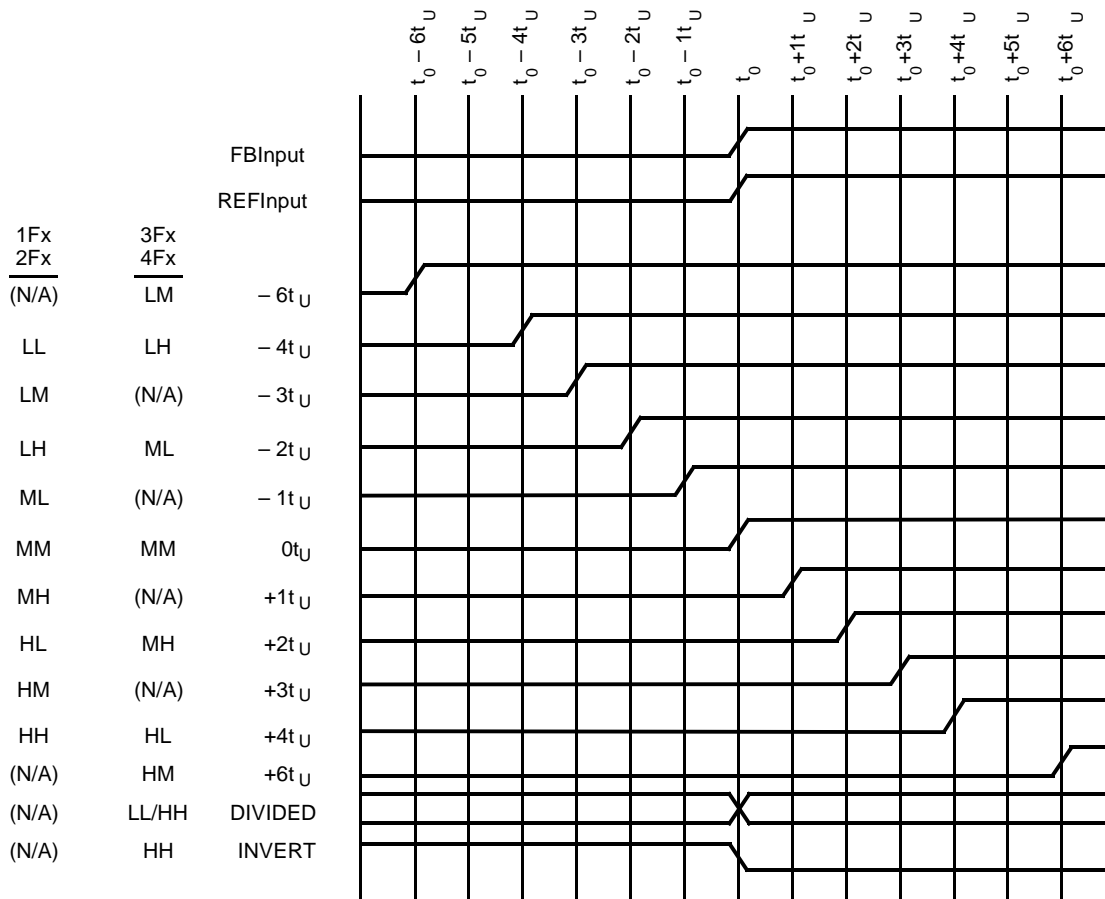

7B991V-3

Figure 1. Typical Outputs with FB Connected to a Zero-Skew Output^[4]

Test Mode

The TEST input is a three-level input. In normal system operation, this pin is connected to ground, allowing the CY7B991V to operate as explained briefly above (for testing purposes, any of the three-level inputs can have a removable jumper to ground, or be tied LOW through a 100Ω resistor. This will allow an external tester to change the state of these pins.)

If the TEST input is forced to its MID or HIGH state, the device will operate with its internal phase locked loop disconnected, and input levels supplied to REF will directly control all outputs. Relative output to output functions are the same as in normal mode.

In contrast with normal operation (TEST tied LOW). All outputs will function based only on the connection of their own function select inputs (xF0 and xF1) and the waveform characteristics of the REF input.

Maximum Ratings

(Above which the useful life may be impaired. For user guidelines, not tested.)

| | |
|--|---------------------------------------|
| Storage Temperature | -65°C to +150°C |
| Ambient Temperature with Power Applied | -55°C to +125°C |
| Supply Voltage to Ground Potential | -0.5V to +7.0V |
| DC Input Voltage | -0.5V to +7.0V |
| Output Current into Outputs (LOW)..... | 64 mA |
| Static Discharge Voltage | >2001V (per MIL-STD-883, Method 3015) |
| Latch-Up Current..... | >200 mA |

Operating Range

| Range | Ambient Temperature | V _{CC} |
|------------|---------------------|-----------------|
| Commercial | 0°C to +70°C | 3.3V ± 10% |
| Industrial | -40°C to +85°C | 3.3V ± 10% |

Note:

- FB connected to an output selected for "zero" skew (i.e., xF1 = xF0 = MID).

Electrical Characteristics Over the Operating Range^[5]

| Parameter | Description | Test Conditions | CY7B991V | | Unit |
|------------------|---|--|------------------------|------------------------|------|
| | | | Min. | Max. | |
| V _{OH} | Output HIGH Voltage | V _{CC} = Min., I _{OH} = -12 mA | 2.4 | | V |
| V _{OL} | Output LOW Voltage | V _{CC} = Min., I _{OL} = 35 mA | | 0.45 | V |
| V _{IH} | Input HIGH Voltage (REF and FB inputs only) | | 2.0 | V _{CC} | V |
| V _{IL} | Input LOW Voltage (REF and FB inputs only) | | -0.5 | 0.8 | V |
| V _{IHH} | Three-Level Input HIGH Voltage (Test, FS, xFn) ^[6] | Min. ≤ V _{CC} ≤ Max. | 0.87 * V _{CC} | V _{CC} | V |
| V _{IMM} | Three-Level Input MID Voltage (Test, FS, xFn) ^[6] | Min. ≤ V _{CC} ≤ Max. | 0.47 * V _{CC} | 0.53 * V _{CC} | V |
| V _{ILL} | Three-Level Input LOW Voltage (Test, FS, xFn) ^[6] | Min. ≤ V _{CC} ≤ Max. | 0.0 | 0.13 * V _{CC} | V |
| I _{IH} | Input HIGH Leakage Current (REF and FB inputs only) | V _{CC} = Max., V _{IN} = Max. | | 20 | μA |
| I _{IL} | Input LOW Leakage Current (REF and FB inputs only) | V _{CC} = Max., V _{IN} = 0.4V | -20 | | μA |
| I _{IHH} | Input HIGH Current (Test, FS, xFn) | V _{IN} = V _{CC} | | 200 | μA |
| I _{IMM} | Input MID Current (Test, FS, xFn) | V _{IN} = V _{CC} /2 | -50 | 50 | μA |
| I _{ILL} | Input LOW Current (Test, FS, xFn) | V _{IN} = GND | | -200 | μA |
| I _{OS} | Short Circuit Current ^[7] | V _{CC} = MAX, V _{OUT} = GND (25° only) | | -200 | mA |
| I _{CCQ} | Operating Current Used by Internal Circuitry | V _{CCN} = V _{CCQ} = Max., All Input Selects Open | Com'l | 95 | mA |
| | | | Mil/Ind | 100 | |
| I _{CCN} | Output Buffer Current per Output Pair ^[8] | V _{CCN} = V _{CCQ} = Max., I _{OUT} = 0 mA Input Selects Open, f _{MAX} | | 19 | mA |
| PD | Power Dissipation per Output Pair ^[9] | V _{CCN} = V _{CCQ} = Max., I _{OUT} = 0 mA Input Selects Open, f _{MAX} | | 104 | mW |

Notes:

- See the last page of this specification for Group A subgroup testing information.
- These inputs are normally wired to V_{CC}, GND, or left unconnected (actual threshold voltages vary as a percentage of V_{CC}). Internal termination resistors hold unconnected inputs at V_{CC}/2. If these inputs are switched, the function and timing of the outputs may glitch and the PLL may require an additional t_{LOCK} time before all datasheet limits are achieved.
- CY7B991V should be tested one output at a time, output shorted for less than one second, less than 10% duty cycle. Room temperature only.
- Total output current per output pair can be approximated by the following expression that includes device current plus load current:
CY7B991V: I_{CCN} = [(4 + 0.11F) + [(835 - 3F)/Z) + (.0022FC)]N x 1.1
Where
F = frequency in MHz
C = capacitive load in pF
Z = line impedance in ohms
N = number of loaded outputs; 0, 1, or 2
FC = F < C
- Total power dissipation per output pair can be approximated by the following expression that includes device power dissipation plus power dissipation due to the load circuit:
PD = [(22 + 0.61F) + [(1550 + 2.7F)/Z) + (.0125FC)]N x 1.1
See note 8 for variable definition.
- Applies to REF and FB inputs only. Tested initially and after any design or process changes that may affect these parameters.

Capacitance^[10]

| Parameter | Description | Test Conditions | Max. | Unit |
|-----------------|-------------------|--|------|------|
| C _{IN} | Input Capacitance | T _A = 25°C, f = 1 MHz, V _{CC} = 3.3V | 10 | pF |

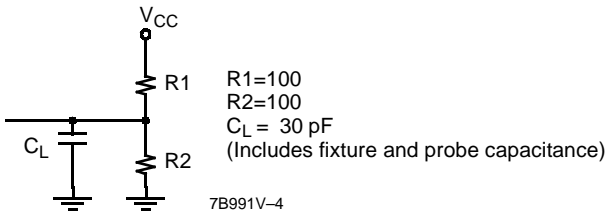
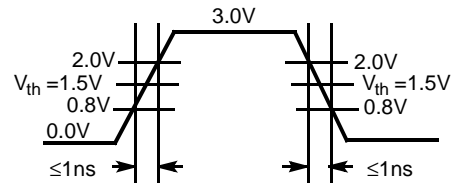
AC Test Loads and Waveforms

TTL AC Test Load

TTL Input Test Waveform

7B991V-5

Switching Characteristics Over the Operating Range^[2, 11]

| Parameter | Description | CY7B991V-2 | | | Unit | |
|---------------------|---|--------------------------------|------|-------|------|-----|
| | | Min. | Typ. | Max. | | |
| f_{NOM} | Operating Clock Frequency in MHz | FS = LOW ^[1, 2] | 15 | | 30 | MHz |
| | | FS = MID ^[1, 2] | 25 | | 50 | |
| | | FS = HIGH ^[1, 2, 3] | 40 | | 80 | |
| t_{RPWH} | REF Pulse Width HIGH | 5.0 | | | ns | |
| t_{RPWL} | REF Pulse Width LOW | 5.0 | | | ns | |
| t_{U} | Programmable Skew Unit | See Table 1 | | | | |
| t_{SKEWPR} | Zero Output Matched-Pair Skew (XQ0, XQ1) ^[13, 14] | | 0.05 | 0.2 | ns | |
| t_{SKEW0} | Zero Output Skew (All Outputs) ^[13, 15] | | 0.1 | 0.25 | ns | |
| t_{SKEW1} | Output Skew (Rise-Rise, Fall-Fall, Same Class Outputs) ^[13, 17] | | 0.1 | 0.5 | ns | |
| t_{SKEW2} | Output Skew (Rise-Fall, Nominal-Inverted, Divided-Divided) ^[13, 17] | | 0.5 | 1.0 | ns | |
| t_{SKEW3} | Output Skew (Rise-Rise, Fall-Fall, Different Class Outputs) ^[13, 17] | | 0.25 | 0.5 | ns | |
| t_{SKEW4} | Output Skew (Rise-Fall, Nominal-Divided, Divided-Inverted) ^[13, 17] | | 0.5 | 0.9 | ns | |
| t_{DEV} | Device-to-Device Skew ^[12, 18] | | | 1.25 | ns | |
| t_{PD} | Propagation Delay, REF Rise to FB Rise | -0.25 | 0.0 | +0.25 | ns | |
| t_{ODCV} | Output Duty Cycle Variation ^[19] | -0.65 | 0.0 | +0.65 | ns | |
| t_{PWH} | Output HIGH Time Deviation from 50% ^[20] | | | 2.0 | ns | |
| t_{PWL} | Output LOW Time Deviation from 50% ^[20] | | | 1.5 | ns | |
| t_{ORISE} | Output Rise Time ^[20, 21] | 0.15 | 1.0 | 1.2 | ns | |
| t_{OFALL} | Output Fall Time ^[20, 21] | 0.15 | 1.0 | 1.2 | ns | |
| t_{LOCK} | PLL Lock Time ^[22] | | | 0.5 | ms | |
| t_{JR} | Cycle-to-Cycle Output Jitter | RMS ^[12] | | 25 | ps | |
| | | Peak-to-Peak ^[12] | | 200 | ps | |

Notes:

- Test measurement levels for the CY7B991V are TTL levels (1.5V to 1.5V). Test conditions assume signal transition times of 2 ns or less and output loading as shown in the AC Test Loads and Waveforms unless otherwise specified.
- Guaranteed by statistical correlation. Tested initially and after any design or process changes that may affect these parameters.
- SKEW is defined as the time between the earliest and the latest output transition among all outputs for which the same t_{U} delay has been selected when all are loaded with 30 pF and terminated with 50Ω to $V_{\text{CC}}/2$ (CY7B991V).
- t_{SKEWPR} is defined as the skew between a pair of outputs (XQ0 and XQ1) when all eight outputs are selected for 0 t_{U} .
- t_{SKEW0} is defined as the skew between outputs when they are selected for 0 t_{U} . Other outputs are divided or inverted but not shifted.
- $C_L=0$ pF. For $C_L=30$ pF, $t_{\text{SKEW0}}=0.35$ ns.
- There are three classes of outputs: Nominal (multiple of t_{U} delay), Inverted (4Q0 and 4Q1 only with 4F0 = 4F1 = HIGH), and Divided (3Qx and 4Qx only in Divide-by-2 or Divide-by-4 mode).
- t_{DEV} is the output-to-output skew between any two devices operating under the same conditions (V_{CC} ambient temperature, air flow, etc.)
- t_{ODCV} is the deviation of the output from a 50% duty cycle. Output pulse width variations are included in t_{SKEW2} and t_{SKEW4} specifications.
- Specified with outputs loaded with 30 pF for the CY7B991V-5 and -7 devices. Devices are terminated through 50Ω to $V_{\text{CC}}/2$. t_{PWH} is measured at 2.0V. t_{PWL} is measured at 0.8V.
- t_{ORISE} and t_{OFALL} measured between 0.8V and 2.0V.
- t_{LOCK} is the time that is required before synchronization is achieved. This specification is valid only after V_{CC} is stable and within normal operating limits. This parameter is measured from the application of a new signal or frequency at REF or FB until t_{PD} is within specified limits.

Switching Characteristics Over the Operating Range^[2, 11] (continued)

| Parameter | Description | CY7B991V-5 | | | Unit | |
|---------------------|---|------------------------------|------|------|------|-----|
| | | Min. | Typ. | Max. | | |
| f _{NOM} | Operating Clock Frequency in MHz | FS = LOW ^[1, 2] | 15 | | 30 | MHz |
| | | FS = MID ^[1, 2] | 25 | | 50 | |
| | | FS = HIGH ^[1, 2] | 40 | | 80 | |
| t _{RPWH} | REF Pulse Width HIGH | 5.0 | | | ns | |
| t _{RPWL} | REF Pulse Width LOW | 5.0 | | | ns | |
| t _U | Programmable Skew Unit | See Table 1 | | | | |
| t _{SKEWPR} | Zero Output Matched-Pair Skew (XQ0, XQ1) ^[13, 14] | | 0.1 | 0.25 | ns | |
| t _{SKEW0} | Zero Output Skew (All Outputs) ^[13, 15] | | 0.25 | 0.5 | ns | |
| t _{SKEW1} | Output Skew (Rise-Rise, Fall-Fall, Same Class Outputs) ^[13, 17] | | 0.6 | 0.7 | ns | |
| t _{SKEW2} | Output Skew (Rise-Fall, Nominal-Inverted, Divided-Divided) ^[13, 17] | | 0.5 | 1.0 | ns | |
| t _{SKEW3} | Output Skew (Rise-Rise, Fall-Fall, Different Class Outputs) ^[13, 17] | | 0.5 | 0.7 | ns | |
| t _{SKEW4} | Output Skew (Rise-Fall, Nominal-Divided, Divided-Inverted) ^[13, 17] | | 0.5 | 1.0 | ns | |
| t _{DEV} | Device-to-Device Skew ^[12, 18] | | | 1.25 | ns | |
| t _{PD} | Propagation Delay, REF Rise to FB Rise | -0.5 | 0.0 | +0.5 | ns | |
| t _{ODCV} | Output Duty Cycle Variation ^[19] | -1.0 | 0.0 | +1.0 | ns | |
| t _{PWH} | Output HIGH Time Deviation from 50% ^[20] | | | 2.5 | ns | |
| t _{PWL} | Output LOW Time Deviation from 50% ^[20] | | | 3 | ns | |
| t _{ORISE} | Output Rise Time ^[20, 21] | 0.15 | 1.0 | 1.5 | ns | |
| t _{OFALL} | Output Fall Time ^[20, 21] | 0.15 | 1.0 | 1.5 | ns | |
| t _{LOCK} | PLL Lock Time ^[22] | | | 0.5 | ms | |
| t _{JR} | Cycle-to-Cycle Output Jitter | RMS ^[12] | | | 25 | ps |
| | | Peak-to-Peak ^[12] | | | 200 | ps |

Switching Characteristics Over the Operating Range^[2, 11] (continued)

| Parameter | Description | CY7B991V-7 | | | Unit | |
|---------------------|---|------------------------------|------|------|------|-----|
| | | Min. | Typ. | Max. | | |
| f _{NOM} | Operating Clock Frequency in MHz | FS = LOW ^[1, 2] | 15 | | 30 | MHz |
| | | FS = MID ^[1, 2] | 25 | | 50 | |
| | | FS = HIGH ^[1, 2] | 40 | | 80 | |
| t _{RPWH} | REF Pulse Width HIGH | 5.0 | | | ns | |
| t _{RPWL} | REF Pulse Width LOW | 5.0 | | | ns | |
| t _U | Programmable Skew Unit | See Table 1 | | | | |
| t _{SKEWPR} | Zero Output Matched-Pair Skew (XQ0, XQ1) ^[13, 14] | | 0.1 | 0.25 | ns | |
| t _{SKEW0} | Zero Output Skew (All Outputs) ^[13, 15] | | 0.3 | 0.75 | ns | |
| t _{SKEW1} | Output Skew (Rise-Rise, Fall-Fall, Same Class Outputs) ^[13, 17] | | 0.6 | 1.0 | ns | |
| t _{SKEW2} | Output Skew (Rise-Fall, Nominal-Inverted, Divided-Divided) ^[13, 17] | | 1.0 | 1.5 | ns | |
| t _{SKEW3} | Output Skew (Rise-Rise, Fall-Fall, Different Class Outputs) ^[13, 17] | | 0.7 | 1.2 | ns | |
| t _{SKEW4} | Output Skew (Rise-Fall, Nominal-Divided, Divided-Inverted) ^[13, 17] | | 1.2 | 1.7 | ns | |
| t _{DEV} | Device-to-Device Skew ^[12, 18] | | | 1.65 | ns | |
| t _{PD} | Propagation Delay, REF Rise to FB Rise | -0.7 | 0.0 | +0.7 | ns | |
| t _{ODCV} | Output Duty Cycle Variation ^[19] | -1.2 | 0.0 | +1.2 | ns | |
| t _{PWH} | Output HIGH Time Deviation from 50% ^[20] | | | 3 | ns | |
| t _{PWL} | Output LOW Time Deviation from 50% ^[20] | | | 3.5 | ns | |
| t _{ORISE} | Output Rise Time ^[20, 21] | 0.15 | 1.5 | 2.5 | ns | |
| t _{OFALL} | Output Fall Time ^[20, 21] | 0.15 | 1.5 | 2.5 | ns | |
| t _{LOCK} | PLL Lock Time ^[22] | | | 0.5 | ms | |
| t _{JR} | Cycle-to-Cycle Output Jitter | RMS ^[12] | | | 25 | ps |
| | | Peak-to-Peak ^[12] | | | 200 | ps |

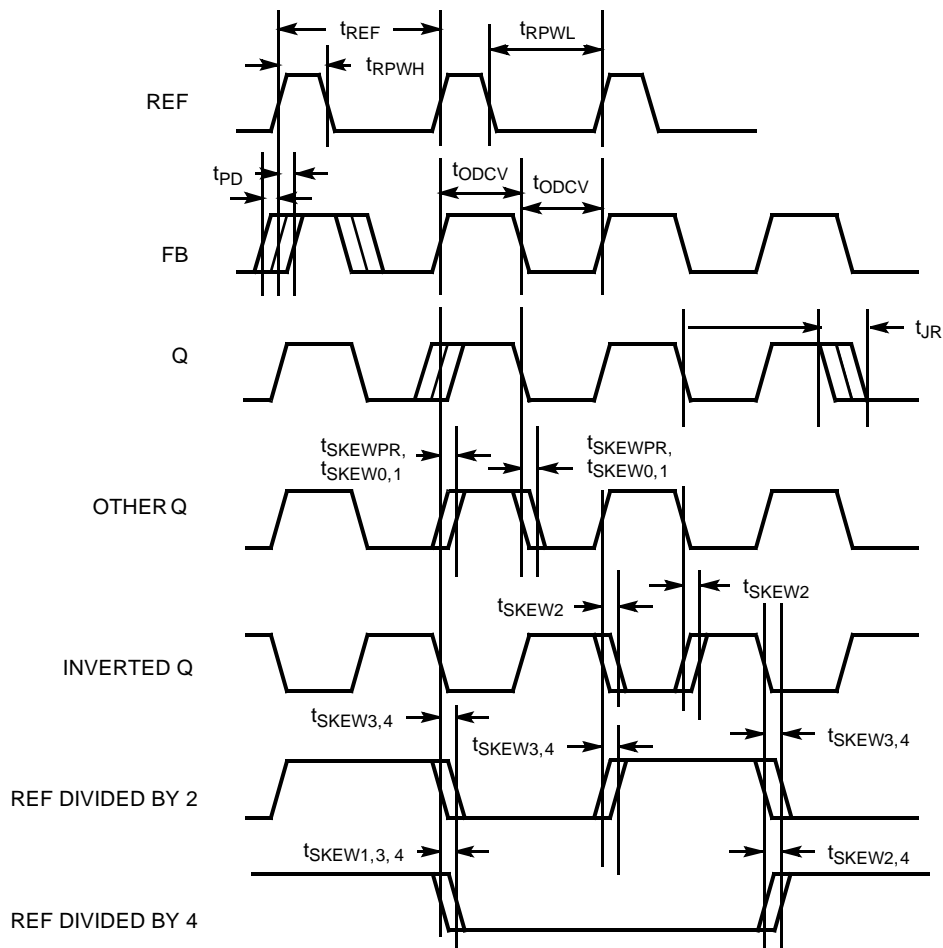
AC Timing Diagrams

7B991V-8

Operational Mode Descriptions

Figure 2. Zero-Skew and/or Zero-Delay Clock Driver

Figure 2 shows the LVPSCB configured as a zero-skew clock buffer. In this mode the CY7B991V can be used as the basis for a low-skew clock distribution tree. When all of the function select inputs (xF0, xF1) are left open, the outputs are aligned and may each drive a terminated transmission line to an independent load. The FB input can be tied to any output in this

configuration and the operating frequency range is selected with the FS pin. The low-skew specification, coupled with the ability to drive terminated transmission lines (with impedances as low as 50 ohms), allows efficient printed circuit board design.

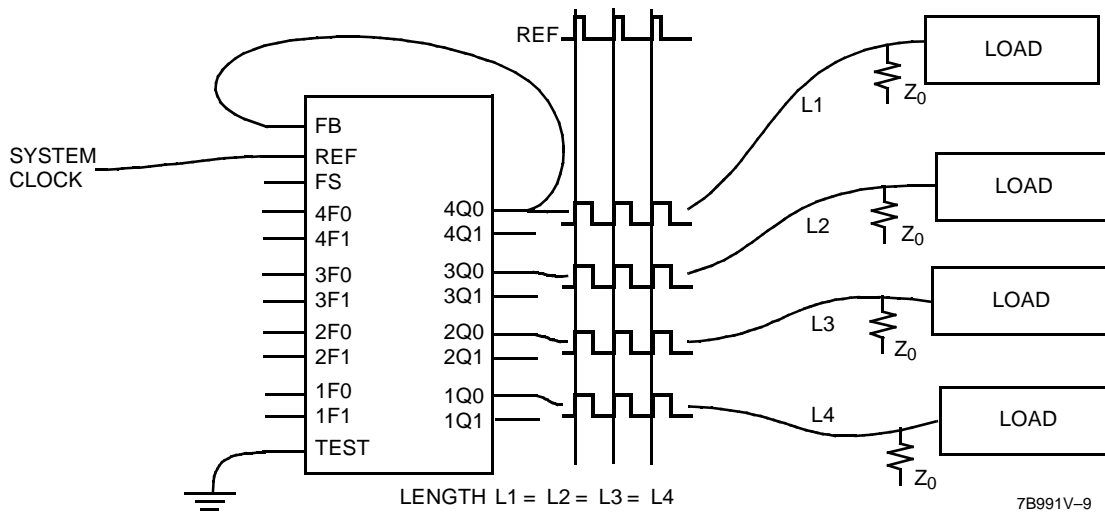
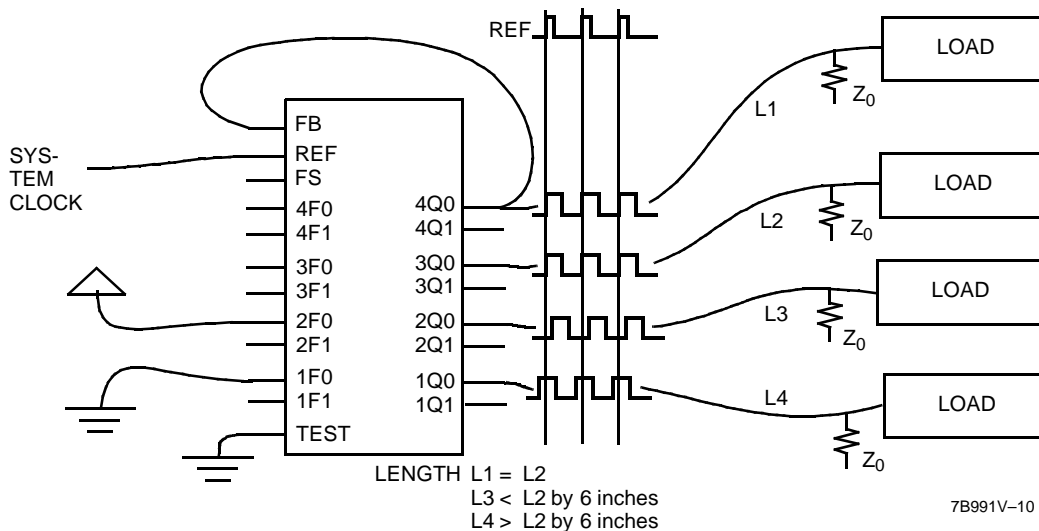

Figure 3. Programmable-Skew Clock Driver

Figure 3 shows a configuration to equalize skew between metal traces of different lengths. In addition to low skew between outputs, the LVPSCB can be programmed to stagger the timing of its outputs. The four groups of output pairs can each be programmed to different output timing. Skew timing can be adjusted over a wide range in small increments with the appropriate strapping of the function select pins. In this configuration the 4Q0 output is fed back to FB and configured for zero skew. The other three pairs of outputs are programmed to yield different skews relative to the feedback. By advancing the clock signal on the longer traces or retarding the clock signal on shorter traces, all loads can receive the clock pulse at the same time.

In this illustration the FB input is connected to an output with 0-ns skew (xF1, xF0 = MID) selected. The internal PLL synchronizes the FB and REF inputs and aligns their rising edges to insure that all outputs have precise phase alignment.

Clock skews can be advanced by ± 6 time units (t_U) when using an output selected for zero skew as the feedback. A wider range of delays is possible if the output connected to FB is also skewed. Since "Zero Skew", $+t_U$, and $-t_U$ are defined relative to output groups, and since the PLL aligns the rising edges of REF and FB, it is possible to create wider output skews by proper selection of the xFn inputs. For example a $+10 t_U$ between REF and 3Qx can be achieved by connecting 1Q0 to FB and setting 1F0 = 1F1 = GND, 3F0 = MID, and 3F1 = High. (Since FB aligns at $-4 t_U$ and 3Qx

skews to +6 t_U, a total of +10 t_U skew is realized.) Many other configurations can be realized by skewing both the output used as the FB input and skewing the other outputs.

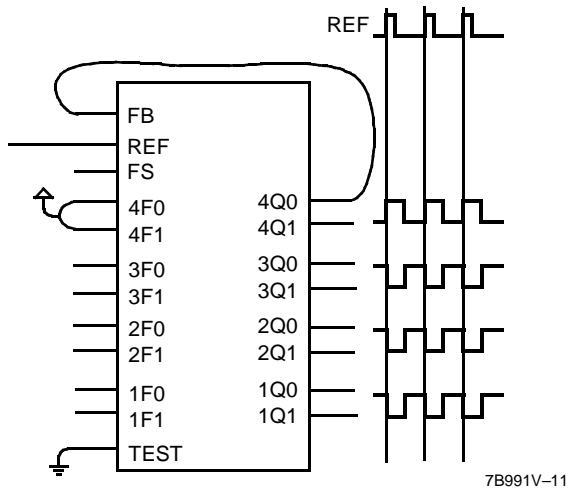

Figure 4. Inverted Output Connections

Figure 4 shows an example of the invert function of the LVPSCB. In this example the 4Q0 output used as the FB input is programmed for invert (4F0 = 4F1 = HIGH) while the other three pairs of outputs are programmed for zero skew. When 4F0 and 4F1 are tied high, 4Q0 and 4Q1 become inverted zero phase outputs. The PLL aligns the rising edge of the FB input with the rising edge of the REF. This causes the 1Q, 2Q, and 3Q outputs to become the “inverted” outputs with respect to the REF input. By selecting which output is connect to FB, it is possible to have 2 inverted and 6 non-inverted outputs or 6 inverted and 2 non-inverted outputs. The correct configuration would be determined by the need for more (or fewer) inverted outputs. 1Q, 2Q, and 3Q outputs can also be skewed to compensate for varying trace delays independent of inversion on 4Q.

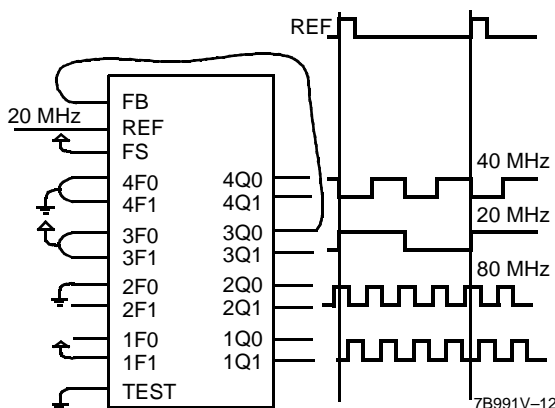

Figure 5. Frequency Multiplier with Skew Connections

Figure 5 illustrates the LVPSCB configured as a clock multiplier. The 3Q0 output is programmed to divide by four and is fed back to FB. This causes the PLL to increase its frequency until the 3Q0 and 3Q1 outputs are locked at 20 MHz while the 1Qx and 2Qx outputs run at 80 MHz. The 4Q0 and 4Q1 outputs are programmed to divide by two, which results in a 40-MHz waveform at these outputs. Note that the 20- and 40-MHz clocks fall

simultaneously and are out of phase on their rising edge. This will allow the designer to use the rising edges of the $\frac{1}{2}$ frequency and $\frac{1}{4}$ frequency outputs without concern for rising-edge skew. The 2Q0, 2Q1, 1Q0, and 1Q1 outputs run at 80 MHz and are skewed by programming their select inputs accordingly. Note that the FS pin is wired for 80-MHz operation because that is the frequency of the fastest output.

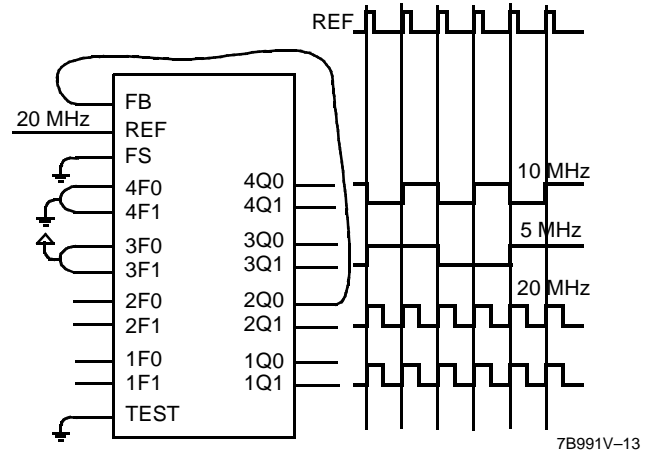

Figure 6. Frequency Divider Connections

Figure 6 demonstrates the LVPSCB in a clock divider application. 2Q0 is fed back to the FB input and programmed for zero skew. 3Qx is programmed to divide by four. 4Qx is programmed to divide by two. Note that the falling edges of the 4Qx and 3Qx outputs are aligned. This allows use of the rising edges of the $\frac{1}{2}$ frequency and $\frac{1}{4}$ frequency without concern for skew mismatch. The 1Qx outputs are programmed to zero skew and are aligned with the 2Qx outputs. In this example, the FS input is grounded to configure the device in the 15- to 30-MHz range since the highest frequency output is running at 20 MHz.

Figure 7 shows some of the functions that are selectable on the 3Qx and 4Qx outputs. These include inverted outputs and outputs that offer divide-by-2 and divide-by-4 timing. An inverted output allows the system designer to clock different subsystems on opposite edges, without suffering from the pulse asymmetry typical of non-ideal loading. This function allows the two subsystems to each be clocked 180 degrees out of phase, but still to be aligned within the skew spec.

The divided outputs offer a zero-delay divider for portions of the system that need the clock to be divided by either two or four, and still remain within a narrow skew of the “1X” clock. Without this feature, an external divider would need to be added, and the propagation delay of the divider would add to the skew between the different clock signals.

These divided outputs, coupled with the Phase Locked Loop, allow the LVPSCB to multiply the clock rate at the REF input by either two or four. This mode will enable the designer to distribute a low-frequency clock between various portions of the system, and then locally multiply the clock rate to a more suitable frequency, while still maintaining the low-skew characteristics of the clock driver. The LVPSCB can perform all of the functions described above at the same time. It can multiply by two and four or divide by two (and four) at the same time that it is shifting its outputs over a wide range or maintaining zero skew between selected outputs.

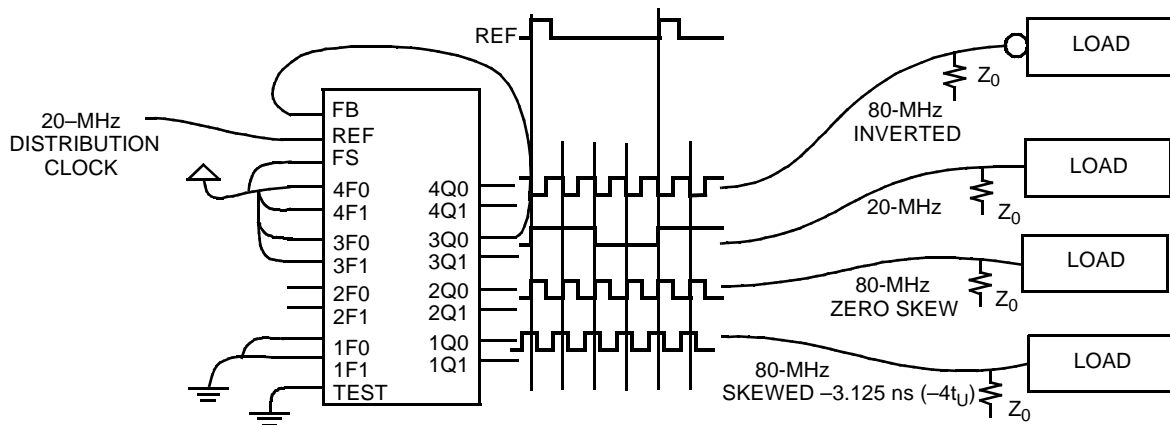

7B991V-14

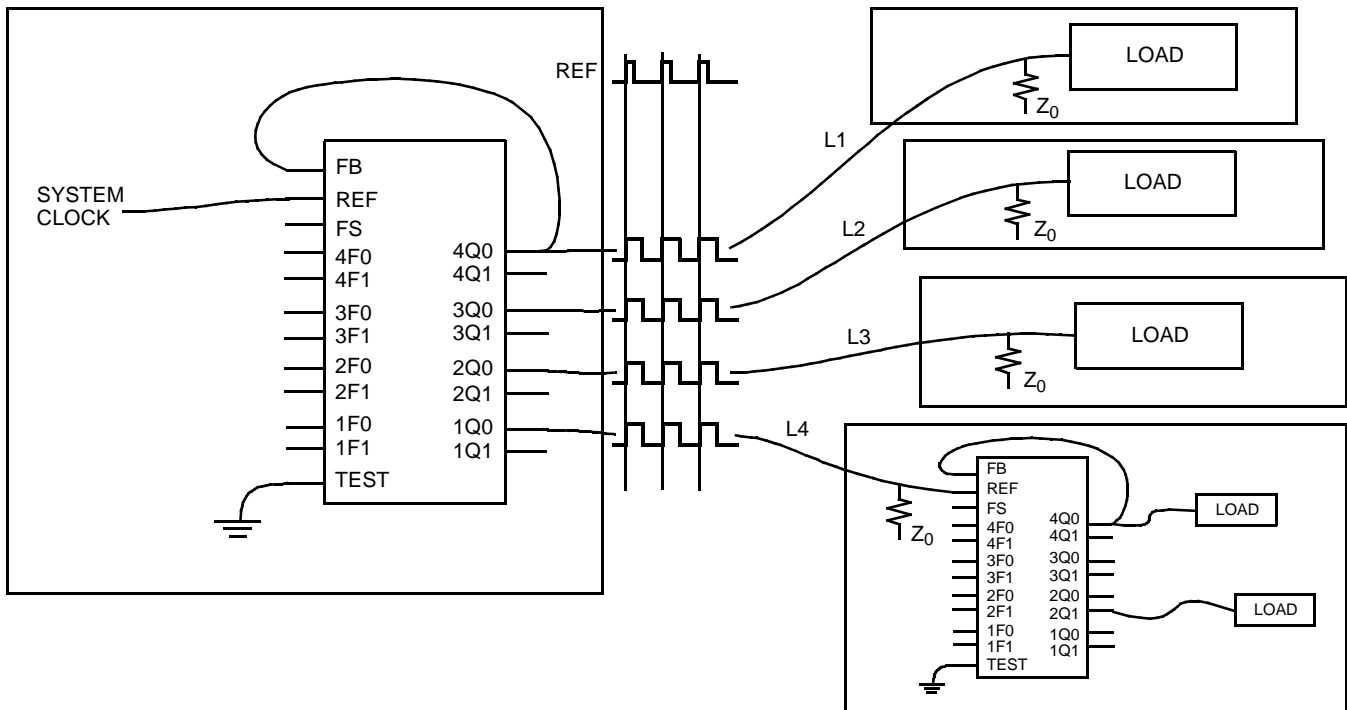
Figure 7. Multi-Function Clock Driver

7B991V-15

Figure 8. Board-to-Board Clock Distribution

Figure 8 shows the CY7B991V connected in series to construct a zero-skew clock distribution tree between boards. Delays of the downstream clock buffers can be programmed to compensate for the wire length (i.e., select negative skew equal to the wire delay) necessary to connect them to the mas-

ter clock source, approximating a zero-delay clock tree. Cascaded clock buffers will accumulate low-frequency jitter because of the non-ideal filtering characteristics of the PLL filter. It is recommended that not more than two clock buffers be connected in series.

Ordering Information

| Accuracy (ps) | Ordering Code | Package Name | Package Type | Operating Range |
|---------------|---------------|--------------|-------------------------------------|-----------------|
| 250 | CY7B991V-2JC | J65 | 32-Lead Plastic Leaded Chip Carrier | Commercial |
| 500 | CY7B991V-5JC | J65 | 32-Lead Plastic Leaded Chip Carrier | Commercial |
| | CY7B991V-5JI | J65 | 32-Lead Plastic Leaded Chip Carrier | Industrial |
| 750 | CY7B991V-7JC | J65 | 32-Lead Plastic Leaded Chip Carrier | Commercial |

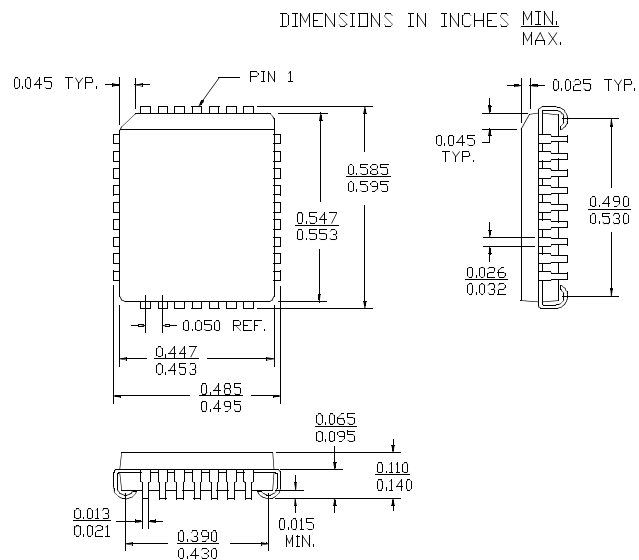
Package Diagram
32-Lead Plastic Leaded Chip Carrier



| Document Title: CY7B991V 3.3V RoboClock Low Voltage Programmable Skew Clock Buffer Document Number: 38-07141 | | | | |
|---|----------------|-------------------|------------------------|---|
| REV. | ECN NO. | Issue Date | Orig. of Change | Description of Change |
| ** | 110250 | 12/17/01 | SZV | Change from Spec number: 38-00641 to 38-07141 |