



# STLVD111

## Programmable low voltage 1:10 differential LVDS clock driver

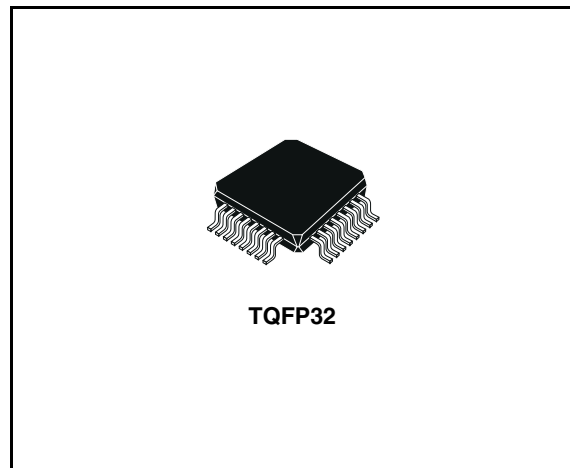
### Features

- 100ps part-to part skew
- 50ps bank skew
- Differential design
- Meets LVDS spec. for driver outputs and receiver inputs
- Reference voltage available output  $V_{BB}$
- Low voltage  $V_{CC}$  range of 2.375V to 2.625V
- High signalling rate capability (exceeds 622MHz)
- Support open, short and terminated input fail-safe (low output state)
- Programmable drivers power off control

### Description

The STLVD111 is a low skew programmable 1 to 10 differential LVDS driver, designed for clock distribution. The select signal is fanned out to 10 identical differential outputs.

The STLVD111 is provided with a 11 bit shift register with a serial in and a Control Register. The purpose is to enable or power off each output clock channel and to select the clock input. The



STLVD111 is specifically designed, modelled and produced with low skew as the key goal. Optimal design and layout serve to minimize gate to gate skew within a device. The net result is a dependable guaranteed low skew device.

The STLVD111 can be used for high performance clock distribution in 2.5V systems with LVDS levels. Designers can take advantage of the device's performance to distribute low skew clocks across the backplane or the board.

### Order codes

| Part number | Temperature range | Package              | Packaging           |
|-------------|-------------------|----------------------|---------------------|
| STLVD111BFR | -40 to 85 °C      | TQFP32 (Tape & Reel) | 2400 parts per reel |

---

## Contents

|          |  |           |
|----------|--|-----------|
| <b>1</b> | <b>Pin configuration</b> .....                 | <b>3</b>  |
| <b>2</b> | <b>Maximum ratings</b> .....                   | <b>5</b>  |
| <b>3</b> | <b>Electrical characteristics</b> .....        | <b>6</b>  |
| <b>4</b> | <b>Specification of control register</b> ..... | <b>8</b>  |
| 4.1      | Programmed mode (EN=1) .....                   | 8         |
| 4.2      | Standard mode (EN=0) .....                     | 8         |
| <b>5</b> | <b>Diagram</b> .....                           | <b>10</b> |
| <b>6</b> | <b>Package mechanical data</b> .....           | <b>15</b> |
| <b>7</b> | <b>Revision history</b> .....                  | <b>18</b> |

# 1 Pin configuration

Figure 1. Pin connections

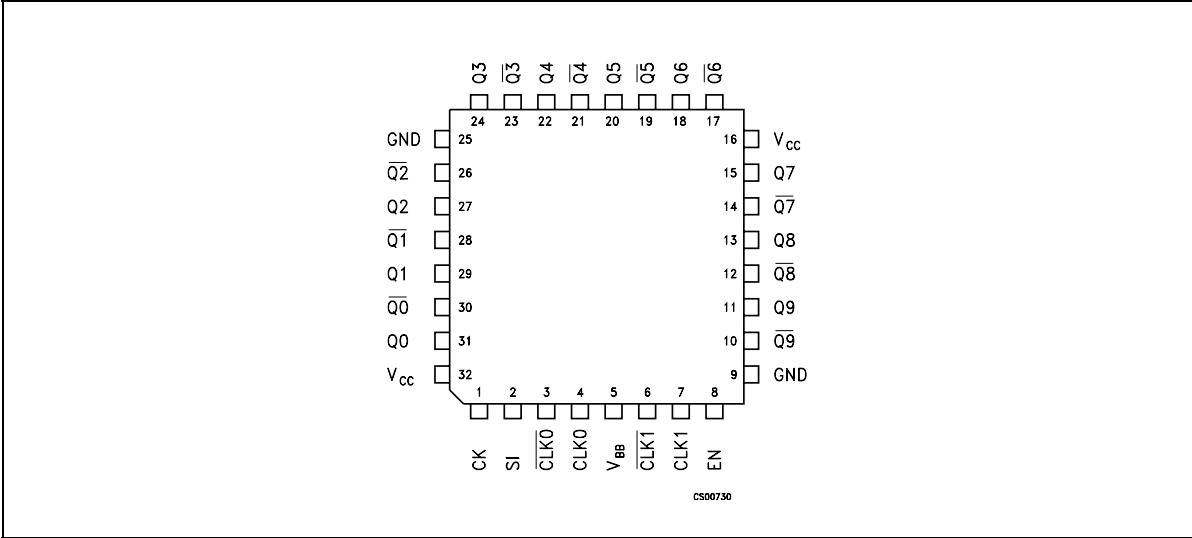


Table 1. Pin description

| Pin n° | Symbol          | Name and function                  |
|--------|-----------------|------------------------------------|
| 1      | CK              | Control register clock             |
| 2      | SI              | Control register serial IN/CLK_SEL |
| 3      | CLK0            | Differential input                 |
| 4      | CLK0            | Differential input                 |
| 5      | V <sub>BB</sub> | Output reference voltage           |
| 6      | CLK1            | Differential input                 |
| 7      | CLK1            | Differential input                 |
| 8      | EN              | Device enable/program              |
| 9      | GND             | Ground                             |
| 10     | Q9              | Differential outputs               |
| 11     | Q9              | Differential outputs               |
| 12     | Q8              | Differential outputs               |
| 13     | Q8              | Differential outputs               |
| 14     | Q7              | Differential outputs               |
| 15     | Q7              | Differential outputs               |
| 16     | V <sub>CC</sub> | Supply voltage                     |
| 17     | Q6              | Differential outputs               |
| 18     | Q6              | Differential outputs               |
| 19     | Q5              | Differential outputs               |
| 20     | Q5              | Differential outputs               |
| 21     | Q4              | Differential outputs               |
| 22     | Q4              | Differential outputs               |
| 23     | Q3              | Differential outputs               |
| 24     | Q3              | Differential outputs               |
| 25     | GND             | Ground                             |
| 26     | Q2              | Differential outputs               |
| 27     | Q2              | Differential outputs               |
| 28     | Q1              | Differential outputs               |
| 29     | Q1              | Differential outputs               |
| 30     | Q0              | Differential outputs               |
| 31     | Q0              | Differential outputs               |
| 32     | V <sub>CC</sub> | Supply voltage                     |

## 2 Maximum ratings

**Table 2. Absolute maximum ratings**

| Symbol    | Parameter   | Value                    | Unit |
|-----------|---|--------------------------|------|
| $V_{CC}$  | Supply voltage                                      | -0.3 to 2.8              | V    |
| $V_I$     | Input voltage                                       | -0.2 to ( $V_{CC}+0.2$ ) | V    |
| $V_O$     | Output voltage                                      | -0.2 to ( $V_{CC}+0.2$ ) | V    |
| $I_{OSD}$ | Driver short circuit current                        | Continuous               |      |
| ESD       | Electrostatic discharge (HBM 1.5K $\Omega$ , 100pF) | >2                       | KV   |

*Note: Absolute Maximum Ratings are those values beyond which damage to the device may occur. Functional operation under these condition is not implied.*

**Table 3. Recommended operating conditions**

| Symbol   | Parameter                            | Min.            | Typ. | Max.              | Unit               |
|----------|--------------------------------------|-----------------|------|-------------------|--------------------|
| $V_{CC}$ | Supply voltage                       | 2.375           |      | 2.625             | V                  |
| $V_{IC}$ | Receiver common mode input voltage   | 0.5( $V_{ID}$ ) |      | 2-0.5( $V_{ID}$ ) | V                  |
| $T_A$    | Operating free-air temperature range | -40             |      | 85                | $^{\circ}\text{C}$ |
| $T_J$    | Operating junction temperature       | -40             |      | 105               | $^{\circ}\text{C}$ |

**Table 4. Thermal data**

| Symbol     | Parameter                        | Value | Unit                        |
|------------|----------------------------------|-------|-----------------------------|
| $R_{thJC}$ | Thermal resistance junction-case | 13    | $^{\circ}\text{C}/\text{W}$ |

### 3 Electrical characteristics

**Table 5. Driver electrical characteristics** ( $T_A = -40$  to  $85$  °C,  $V_{CC} = 2.5V \pm 5\%$ , unless otherwise specified *Note: 1, 2*)

| Symbol          | Parameter  | Test condition                       | Min. | Typ. | Max. | Unit |
|-----------------|--|--------------------------------------|------|------|------|------|
| $V_{OD}$        | Output differential voltage ( <i>Figure 4.</i> ) | $R_L = 100 \Omega$                   | 400  | 500  | 600  | mV   |
| $\Delta V_{OD}$ | $V_{OD}$ magnitude change                        |                                      |      |      | 30   | mV   |
| $V_{OS}$        | Offset voltage                                   | $-40 \leq T_A \leq 85^\circ\text{C}$ | 1.05 | 1.15 | 1.25 | V    |
| $\Delta V_{OS}$ | $V_{OS}$ magnitude change                        |                                      |      |      | 30   | V    |
| $I_{OS}$        | Output short circuit current                     | $V_O = 0V$                           |      | 15   | 30   | mA   |
|                 |  | $V_{OD} = 0V$                        |      | 7    | 15   |      |

*Note: 1 All currents into device pins are positive; all currents out of device pins are negative. All voltages are referenced to device ground unless otherwise specified.*

*2 All typical values are given for  $V_{CC} = 2.5V$  and  $T_A = 25^\circ\text{C}$  unless otherwise stated*

**Table 6. Receiver electrical characteristics** ( $T_A = -40$  to  $85$  °C,  $V_{CC} = 2.5V \pm 5\%$ , unless otherwise specified *Note: 1, 2*)

| Symbol    | Parameter            | Test condition  | Min. | Typ. | Max. | Unit          |
|-----------|----------------------|-----------------|------|------|------|---------------|
| $V_{IDH}$ | Input threshold high |                 |      |      | 100  | mV            |
| $V_{IDL}$ | Input threshold low  |                 | -100 |      |      | mV            |
| $I_{IN}$  | Input current        | $V_I = 0V$      |      | 42   | 100  | $\mu\text{A}$ |
|           |                      | $V_I = 0V_{CC}$ |      | 2    | 10   |               |

*Note: 1 All currents into device pins are positive; all currents out of device pins are negative. All voltages are referenced to device ground unless otherwise specified.*

*2 All typical values are given for  $V_{CC} = 2.5V$  and  $T_A = 25^\circ\text{C}$  unless otherwise stated*

**Table 7. Driver electrical characteristics** ( $T_A = -40$  to  $85$  °C,  $V_{CC} = 2.5V \pm 5\%$ , unless otherwise specified *Note: 1, 2*)

| Symbol    | Parameter                  | Test condition                              | Min. | Typ. | Max.     | Unit    |
|-----------|----------------------------|---|------|------|----------|---------|
| $V_{BB}$  | Output reference voltage   | $V_{CC} = 2.5 V$                            | 1.15 | 1.25 | 1.35     | V       |
| $I_{CCD}$ | Power supply current       | All driver enabled and loaded               |      | 125  | 160      | mA      |
| $C_{IN}$  | Input capacitance          | $V_I = 0V$ to $V_{CC}$                      |      | 5    |          | pF      |
| $C_{OUT}$ | Output capacitance         |   |      | 5    |          | pF      |
| $V_{IH}$  | Logic input high threshold | $V_{CC} = 2.5 V$                            | 2    |      |          | V       |
| $V_{IL}$  | Logic input low threshold  | $V_{CC} = 2.5 V$                            |      |      | 0.8      | V       |
| $I_I$     | Logic input current        | $V_{CC} = 2.5 V$ , $V_{IN} = V_{CC}$ or GND |      |      | $\pm 10$ | $\mu A$ |

*Note: 1 All currents into device pins are positive; all currents out of device pins are negative. All voltages are referenced to device ground unless otherwise specified*

*2 All typical values are given for  $V_{CC} = 2.5V$  and  $T_A = 25^\circ C$  unless otherwise stated*

**Table 8. LVDS timing characteristics** ( $T_A = -40$  to  $85$  °C,  $V_{CC} = 2.5V \pm 5\%$ , unless otherwise specified)

| Symbol                | Parameter               | Test condition   | Min. | Typ. | Max. | Unit |
|-----------------------|-------------------------|--|------|------|------|------|
| $t_{TLH}$ , $t_{THL}$ | Transition time         | $R_L = 100 \Omega$ , $C_L = 5$ pF,<br><i>Figure 7., Figure 8.)</i> |      | 220  | 300  | ps   |
| $t_{PHL}$ , $t_{PLH}$ | Propagation delay time  | <i>(Figure 7., Figure 8.)</i>                                      |      | 2    | 2.5  | ns   |
| $f_{MAX}$             | Maximum input frequency |  | 700  | 900  |      | MHz  |
| $t_{SKEW}$            | Bank skew               | <i>(Figure 3.)</i>   |      | 50   |      | ps   |
|                       | Part to part skew       | <i>(Figure 4.)</i>   |      | 100  |      |      |
|                       | Pulse skew              | <i>(Figure 5.)</i>   |      | 50   |      |      |

**Table 9. Control register timing characteristics** ( $T_A = -40$  to  $85$  °C,  $V_{CC} = 2.5V \pm 5\%$ , unless otherwise specified)

| Symbol    | Parameter                           | Test condition     | Min. | Typ. | Max. | Unit |
|-----------|-------------------------------------|--------------------|------|------|------|------|
| $f_{MAX}$ | Maximum frequency of shift register | <i>(Figure 9.)</i> | 100  | 150  |      | MHz  |
| $t_s$     | Clock to SI setup time              | <i>(Figure 9.)</i> |      |      | 2    | ns   |
| $t_h$     | Clock to SI hold time               | <i>(Figure 9.)</i> |      |      | 1.5  | ns   |
| $t_{rem}$ | Enable to clock removal time        | <i>(Figure 9.)</i> |      |      | 1.5  | ns   |
| $t_w$     | Minimum clock pulse width           | <i>(Figure 9.)</i> | 3    |      |      | ns   |

## 4 Specification of control register

The STLVD111 is provided with a 11 bit shift register with a Serial In and a Control Register. The purpose is to enable or power of each output clock channel and to select the clock input. The STLVD111 provides two working modality:

### 4.1 Programmed mode (EN=1)

The shift register have a serial input to load the working configuration. Once the configuration is loaded with 11 clock pulse, another clock pulse load the configuration into the control register. The first bit on the serial input line enables the outputs Q9 and Q9, the second bit enables the outputs Q8 and Q8 and so on. The last bit is the clock selection bit. To restart the configuration of the shift register a reset of the state machine must be done with a clock pulse on CK and the EN set to Low. The control register shift register can be configured on time after each reset.

### 4.2 Standard mode (EN=0)

In Standard Mode the STLVD111 isn't programmable, all the clock outputs are enabled. The LVDS clock input is selected from Clock 0 or Clock 1 with the SI pin as shown in the Truth Table below.

**Table 10. Truth table of state machine inputs**

| EN | SI | CK | Output  |
|----|----|----|---|
| L  | L  | X  | All output enabled, Clock 0 selected, control register disabled       |
| L  | H  | X  | All output enabled, Clock 1 selected, control register disabled       |
| H  | L  | ┌┐ | First stage stores "L", other stages store the data of previous stage |
| H  | H  | ┌┐ | First stage stores "H", other stages store the data of previous stage |
| L  | X  | ┌┐ | Reset of the state machine, shift register and control register       |

**Table 11. Serial input sequence**

| BIT#10  | BIT#9 | BIT#8 | BIT#7 | BIT#6 | BIT#5 | BIT#4 | BIT#3 | BIT#2 | BIT#1 | BIT#0 |
|---------|-------|-------|-------|-------|-------|-------|-------|-------|-------|-------|
| CLK_SEL | Q0    | Q1    | Q2    | Q3    | Q4    | Q5    | Q6    | Q7    | Q8    | Q9    |

**Table 12. Truth table of the control register**

| BIT#10 | BIT#(0-9) | Qn(0-9)            |
|--------|-----------|--------------------|
| L      | H         | Clock 0            |
| H      | H         | Clock 1            |
| X      | L         | Qn Output Disabled |

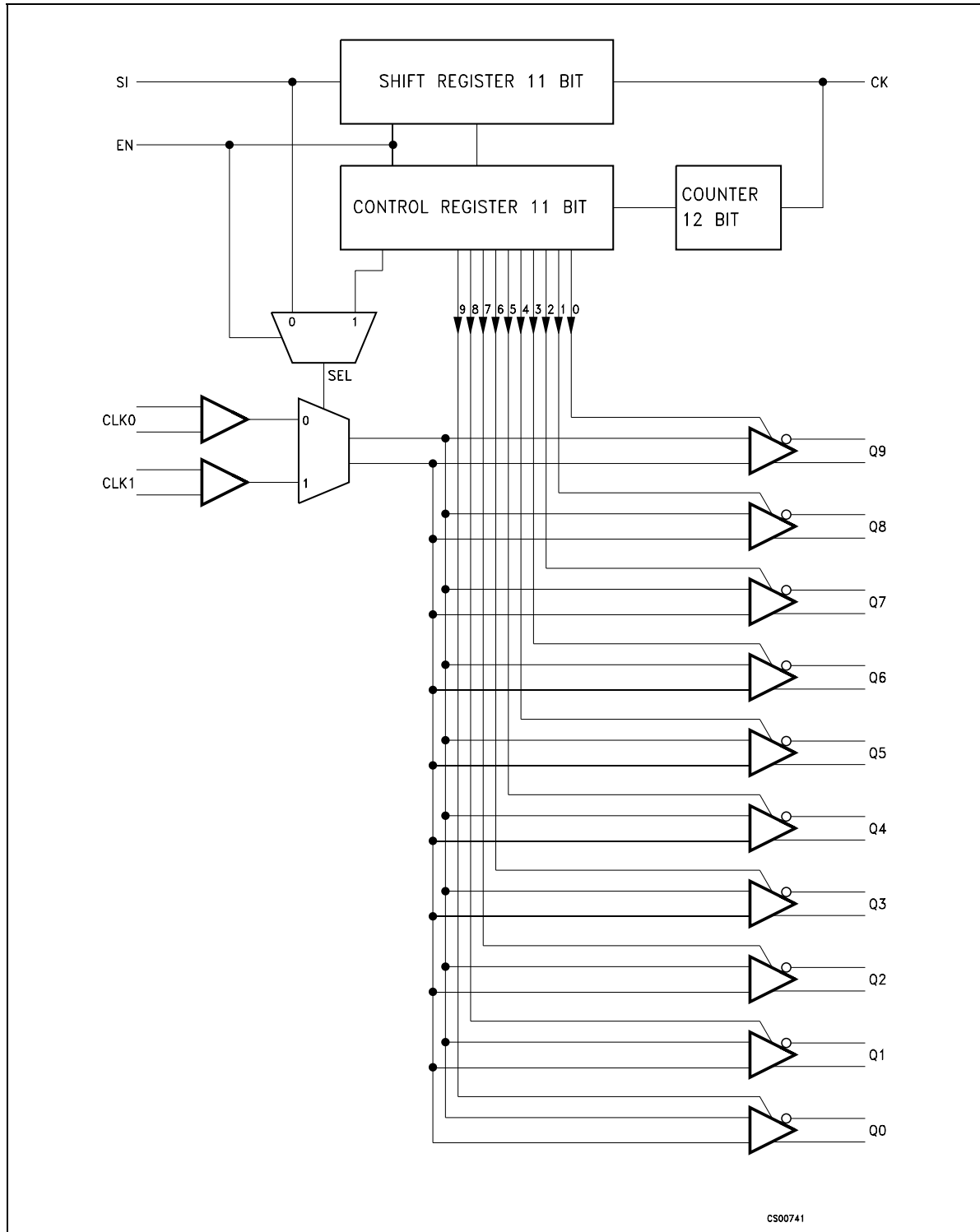


Table 13. Truth table

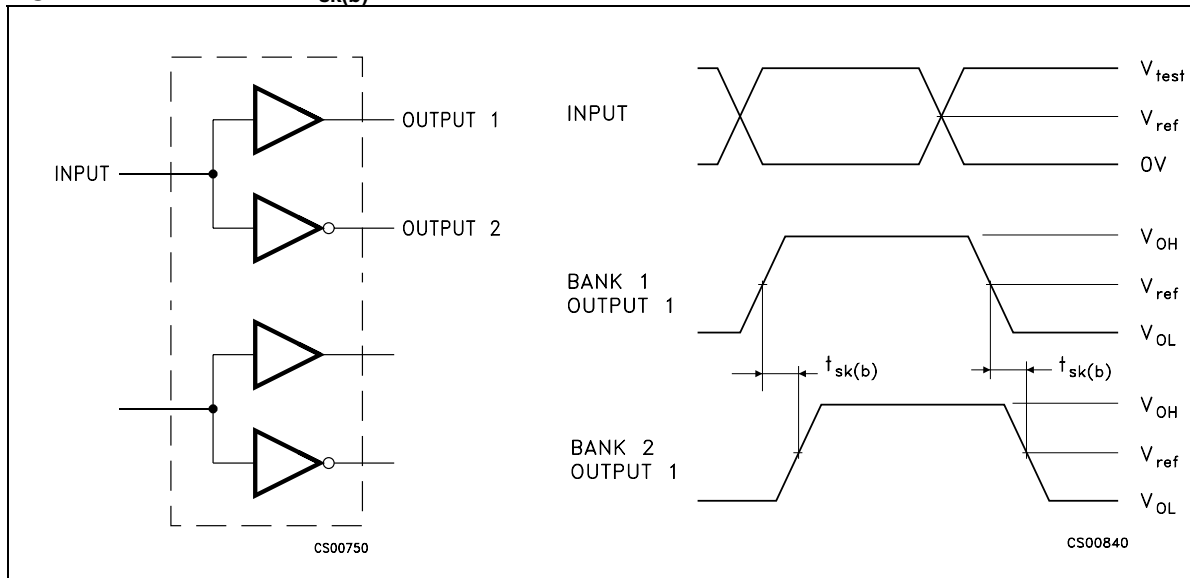
| CK                 | EN | SI | CLK 0 | $\overline{\text{CLK 0}}$ | CLK 1 | $\overline{\text{CLK 1}}$ | Q (0-9) | $\overline{\text{Q}}(0-9)$ |
|--------------------|----|----|-------|---------------------------|-------|---------------------------|---------|----------------------------|
| L                  | L  | L  | L     | H                         | X     | X                         | L       | H                          |
| L                  | L  | L  | H     | L                         | X     | X                         | H       | L                          |
| L                  | L  | L  | Open  | Open                      | X     | X                         | L       | H                          |
| L                  | L  | H  | X     | X                         | L     | H                         | L       | H                          |
| L                  | L  | H  | X     | X                         | H     | L                         | H       | L                          |
| L                  | L  | H  | X     | X                         | Open  | Open                      | L       | H                          |
| All drivers enable |    |    |       |                           |       |                           |         |                            |

## 5 Diagram

Figure 2. Logic diagram

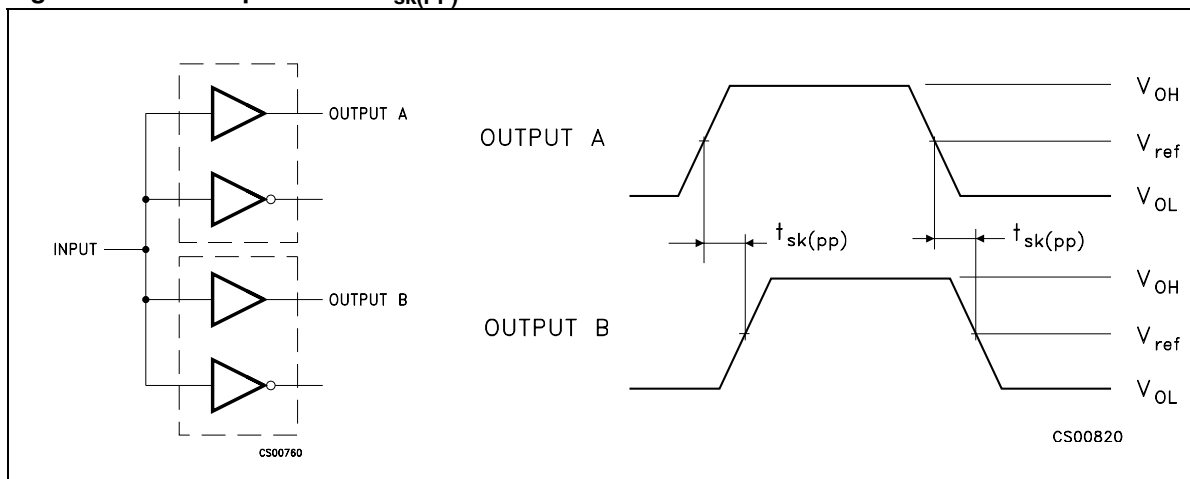


**Figure 3. Bank skew -  $t_{sk(b)}$  <sup>(1)</sup>**



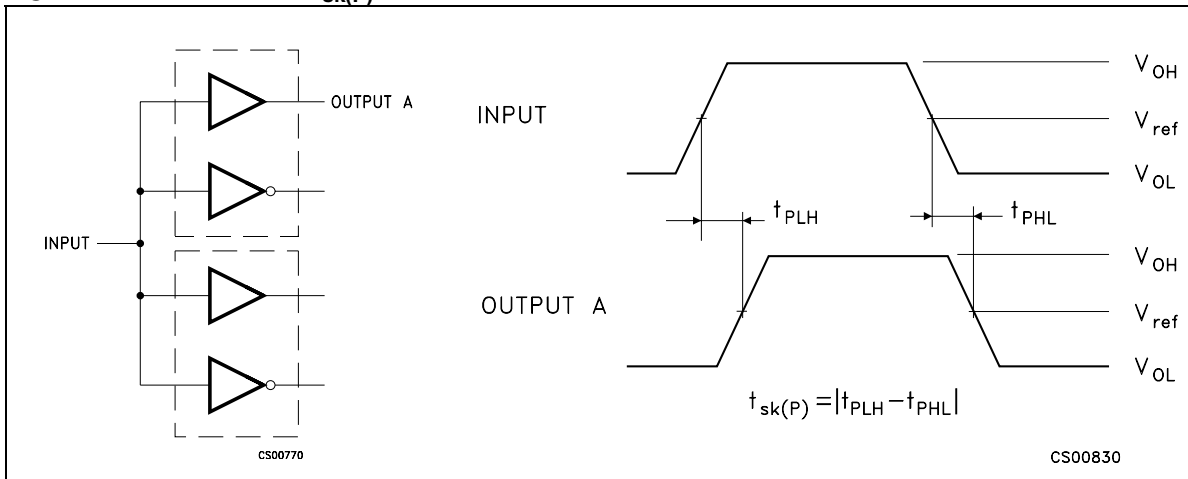
1. BANKSKEW is the magnitude of the time difference between outputs with a single driving input terminal

**Figure 4. Part to part skew -  $t_{sk(pp)}$  <sup>(1)</sup>**



1. PART TO PART SKEW is the magnitude of the difference in propagation delay times between any specific terminals of two devices when both devices operate with the same input signals, the same supply voltages, and the same temperature, and have identical packages and test circuits.

Figure 5. Pulse skew -  $t_{sk(P)}$  <sup>(1)</sup>



1. PULSE SKEW is the magnitude of the time difference between the high to low and low to high propagation delay times at an output.

Figure 6. Voltage and current definition

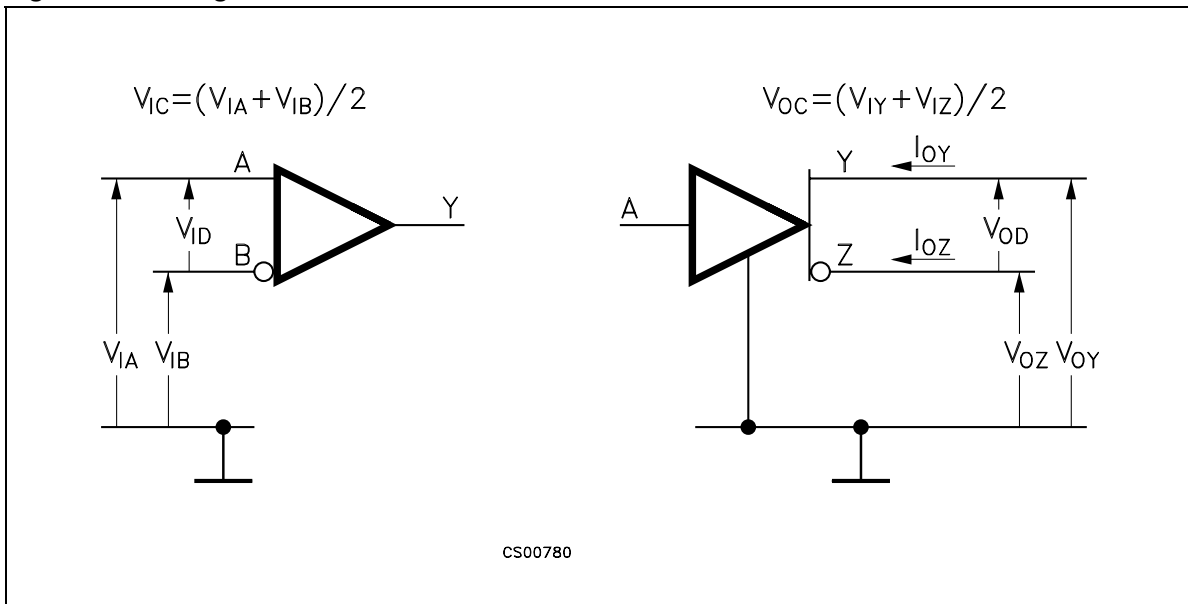


Figure 7. Test circuit and voltage definition for the differential output signal

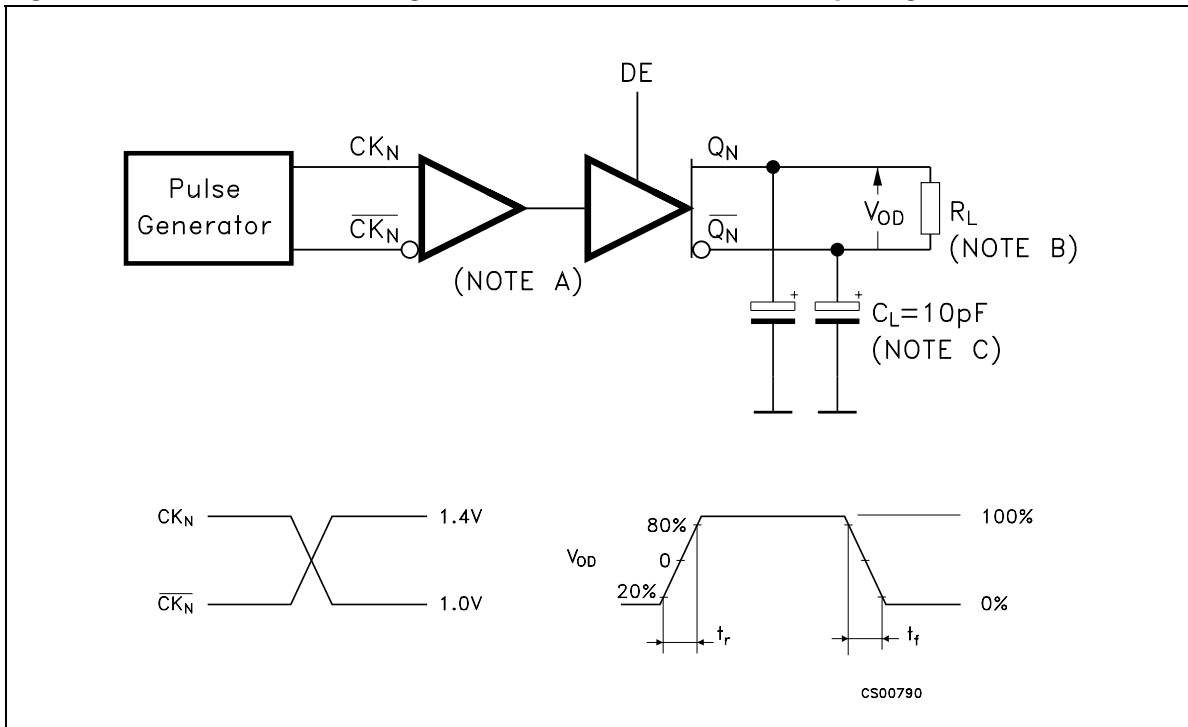


Figure 8. Differential receiver to drive propagation delay and drive transition time waveforms

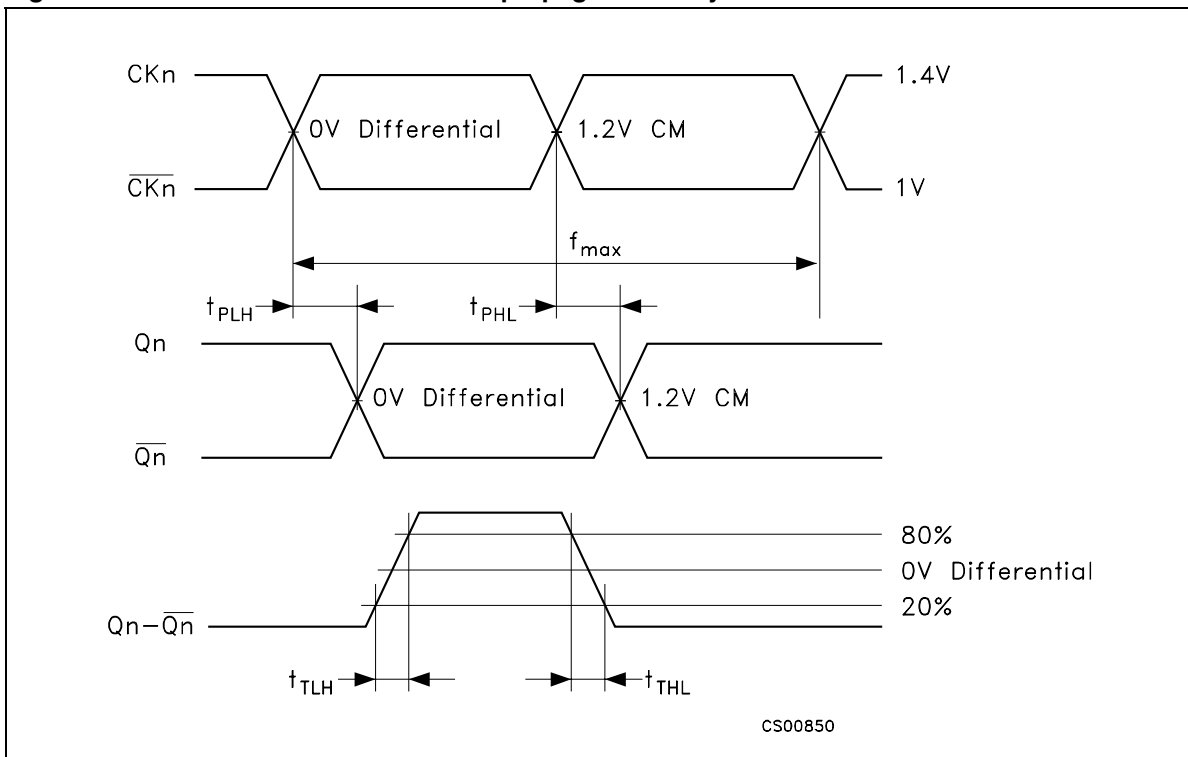
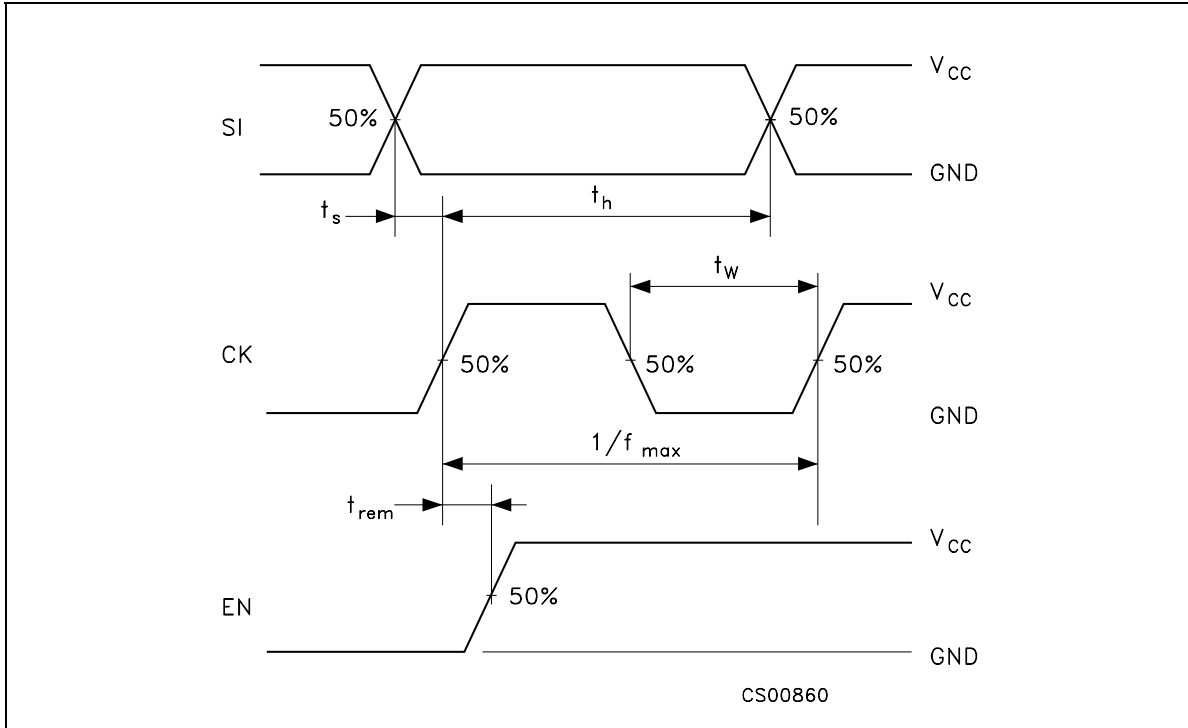


Figure 9. Set-Up, hold and the removal time, maximum frequency, minimum pulse width waveforms

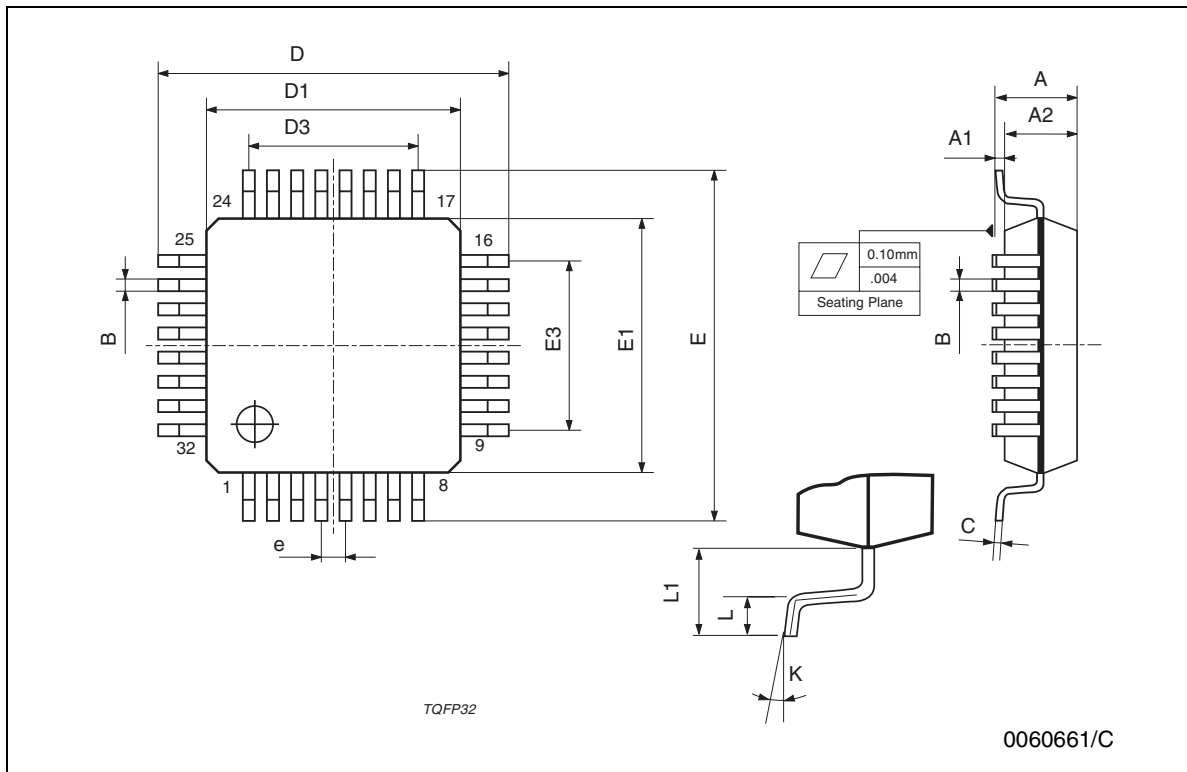


## 6 Package mechanical data

In order to meet environmental requirements, ST offers these devices in ECOPACK<sup>®</sup> packages. These packages have a Lead-free second level interconnect. The category of second Level Interconnect is marked on the package and on the inner box label, in compliance with JEDEC Standard JESD97. The maximum ratings related to soldering conditions are also marked on the inner box label. ECOPACK is an ST trademark. ECOPACK specifications are available at: [www.st.com](http://www.st.com).

### TQFP32 MECHANICAL DATA

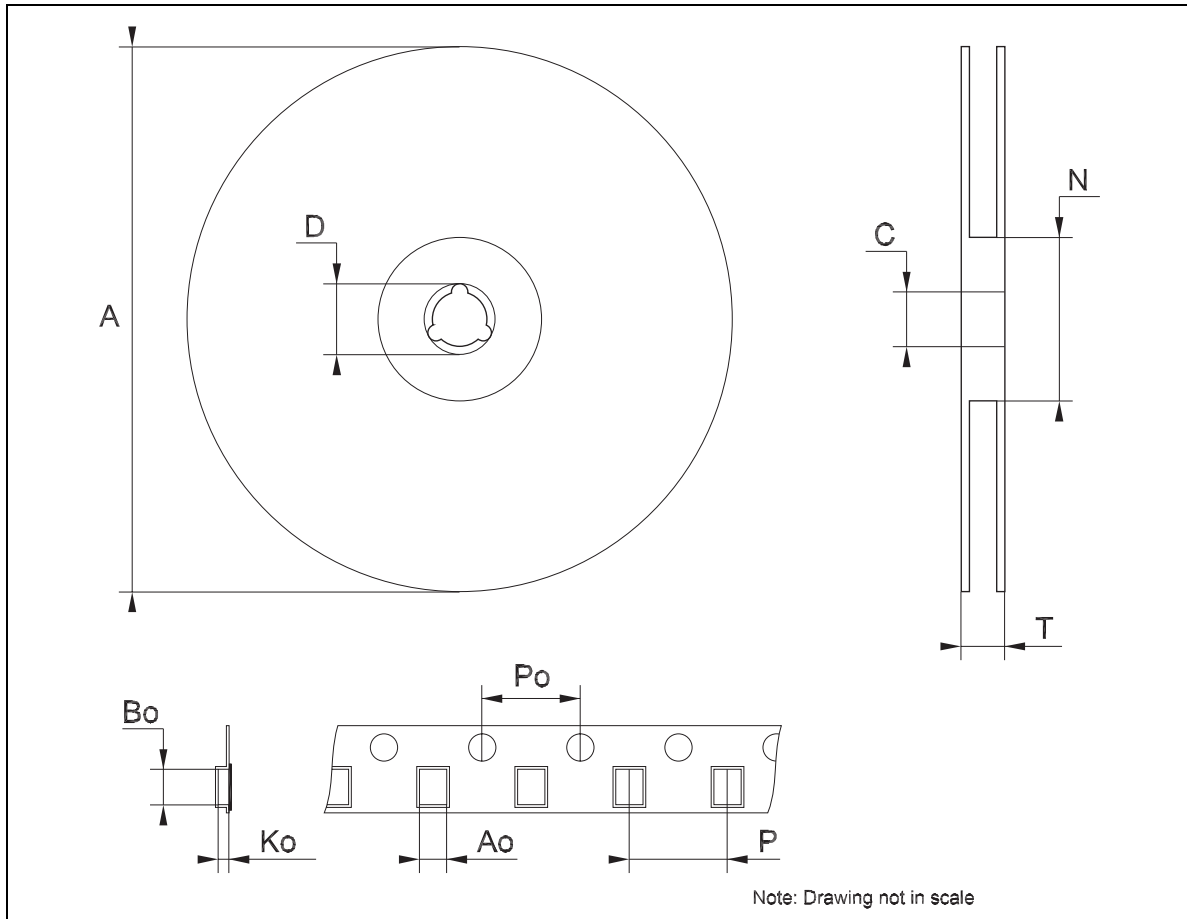
| DIM. | mm.  |      |      | inch   |       |        |
|------|------|------|------|--------|-------|--------|
|      | MIN. | TYP  | MAX. | MIN.   | TYP.  | MAX.   |
| A    |      |      | 1.6  |        |       | 0.063  |
| A1   | 0.05 |      | 0.15 | 0.002  |       | 0.006  |
| A2   | 1.35 | 1.40 | 1.45 | 0.053  | 0.055 | 0.057  |
| B    | 0.30 | 0.37 | 0.45 | 0.012  | 0.015 | 0.018  |
| C    | 0.09 |      | 0.20 | 0.0035 |       | 0.0079 |
| D    |      | 9.00 |      |        | 0.354 |        |
| D1   |      | 7.00 |      |        | 0.276 |        |
| D3   |      | 5.60 |      |        | 0.220 |        |
| e    |      | 0.80 |      |        | 0.031 |        |
| E    |      | 9.00 |      |        | 0.354 |        |
| E1   |      | 7.00 |      |        | 0.276 |        |
| E3   |      | 5.60 |      |        | 0.220 |        |
| L    | 0.45 | 0.60 | 0.75 | 0.018  | 0.024 | 0.030  |
| L1   |      | 1.00 |      |        | 0.039 |        |
| K    | 0°   | 3.5° | 7°   | 0°     | 3.5°  | 7°     |





**Tape & Reel TQFP32 MECHANICAL DATA**

| DIM. | mm.  |      |      | inch  |      |        |
|------|------|------|------|-------|------|--------|
|      | MIN. | TYP. | MAX. | MIN.  | TYP. | MAX.   |
| A    |      |      | 330  |       |      | 12.992 |
| C    | 12.8 |      | 13.2 | 0.504 |      | 0.519  |
| D    | 20.2 |      |      | 0.795 |      |        |
| N    | 60   |      |      | 2.362 |      |        |
| T    |      |      | 22.4 |       |      | 0.882  |
| Ao   | 9.5  |      | 9.7  | 0.374 |      | 0.382  |
| Bo   | 9.5  |      | 9.7  | 0.374 |      | 0.382  |
| Ko   | 2.1  |      | 2.3  | 0.083 |      | 0.091  |
| Po   | 3.9  |      | 4.1  | 0.153 |      | 0.161  |
| P    | 11.9 |      | 12.1 | 0.468 |      | 0.476  |



## 7 Revision history

**Table 14. Revision history**

| Date        | Revision | Changes   |
|-------------|----------|---|
| 30-May-2007 | 8        | Order codes has been updated and the document has been reformatted. |

**Please Read Carefully:**

Information in this document is provided solely in connection with ST products. STMicroelectronics NV and its subsidiaries ("ST") reserve the right to make changes, corrections, modifications or improvements, to this document, and the products and services described herein at any time, without notice.

All ST products are sold pursuant to ST's terms and conditions of sale.

Purchasers are solely responsible for the choice, selection and use of the ST products and services described herein, and ST assumes no liability whatsoever relating to the choice, selection or use of the ST products and services described herein.

No license, express or implied, by estoppel or otherwise, to any intellectual property rights is granted under this document. If any part of this document refers to any third party products or services it shall not be deemed a license grant by ST for the use of such third party products or services, or any intellectual property contained therein or considered as a warranty covering the use in any manner whatsoever of such third party products or services or any intellectual property contained therein.

**UNLESS OTHERWISE SET FORTH IN ST'S TERMS AND CONDITIONS OF SALE ST DISCLAIMS ANY EXPRESS OR IMPLIED WARRANTY WITH RESPECT TO THE USE AND/OR SALE OF ST PRODUCTS INCLUDING WITHOUT LIMITATION IMPLIED WARRANTIES OF MERCHANTABILITY, FITNESS FOR A PARTICULAR PURPOSE (AND THEIR EQUIVALENTS UNDER THE LAWS OF ANY JURISDICTION), OR INFRINGEMENT OF ANY PATENT, COPYRIGHT OR OTHER INTELLECTUAL PROPERTY RIGHT.**

**UNLESS EXPRESSLY APPROVED IN WRITING BY AN AUTHORIZED REPRESENTATIVE OF ST, ST PRODUCTS ARE NOT DESIGNED, AUTHORIZED OR WARRANTED FOR USE IN MILITARY, AIR CRAFT, SPACE, LIFE SAVING, OR LIFE SUSTAINING APPLICATIONS, NOR IN PRODUCTS OR SYSTEMS, WHERE FAILURE OR MALFUNCTION MAY RESULT IN PERSONAL INJURY, DEATH, OR SEVERE PROPERTY OR ENVIRONMENTAL DAMAGE.**

Resale of ST products with provisions different from the statements and/or technical features set forth in this document shall immediately void any warranty granted by ST for the ST product or service described herein and shall not create or extend in any manner whatsoever, any liability of ST.

ST and the ST logo are trademarks or registered trademarks of ST in various countries.

Information in this document supersedes and replaces all information previously supplied.

The ST logo is a registered trademark of STMicroelectronics. All other names are the property of their respective owners.

© 2007 STMicroelectronics - All rights reserved

STMicroelectronics group of companies

Australia - Belgium - Brazil - Canada - China - Czech Republic - Finland - France - Germany - Hong Kong - India - Israel - Italy - Japan - Malaysia - Malta - Morocco - Singapore - Spain - Sweden - Switzerland - United Kingdom - United States of America

[www.st.com](http://www.st.com)

