

# NB6L16

## 2.5V / 3.3V Multilevel Input to Differential LVPECL/LVNECL Clock or Data Receiver/Driver/Translator Buffer

The NB6L16 is a high precision, low power ECL differential clock or data receiver/driver/translator buffer. The device is functionally equivalent to the EL16, EP16, LVEL16 and NBSG16 devices. With output transition times of 70 ps, it is ideally suited for high frequency, low power systems. The device is targeted for Backplane buffering, GbE clock/data distribution, Fibre Channel distribution and SONET clock/data distribution applications.

Input accept LVNECL (Negative ECL), LVPECL (Positive ECL), LVTTTL, LVCMOS, CML, or LVDS. Outputs are 800 mV ECL signals.

The  $V_{BB}$  pin, an internally generated voltage supply, is available to this device only. For single-ended input conditions, the unused differential input is connected to  $V_{BB}$  as a switching reference voltage.  $V_{BB}$  may also rebias AC coupled inputs. When used, decouple  $V_{BB}$  and  $V_{CC}$  via a 0.01  $\mu$ F capacitor and limit current sourcing or sinking to 0.5 mA. When not used,  $V_{BB}$  should be left open.

### Features

- Input Clock Frequency  $\geq 6$  GHz
- Input Data Rate Frequency  $\geq 6$  Gb/s
- Low 12 mA Typical Power Supply Current
- 70 ps Typical Rise/Fall Times
- 130 ps Input Propagation Delay
- On-Chip Reference for ECL Single-Ended Input –  $V_{BB}$  Output
- PECL Mode Operating Range:  
 $V_{CC} = 2.375$  V to 3.465 V with  $V_{EE} = 0$  V
- NECL Mode Operating Range:  
 $V_{CC} = 0$  V with  $V_{EE} = -2.375$  V to  $-3.465$  V
- Open Input Default State
- LVDS, LVPECL, LVNECL, LVCMOS, LVTTTL and CML Input Compatible
- Pb-Free Packages are Available



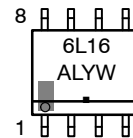
ON Semiconductor®

<http://onsemi.com>

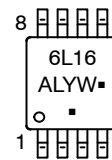
### MARKING DIAGRAMS\*



SOIC-8  
D SUFFIX  
CASE 751



TSSOP-8  
DT SUFFIX  
CASE 948R



A = Assembly Location  
L = Wafer Lot  
Y = Year  
W = Work Week  
▪ = Pb-Free Package

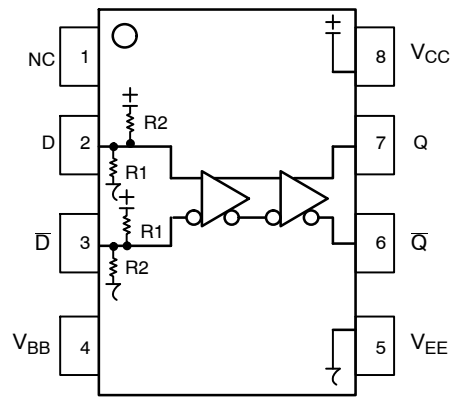
(Note: Microdot may be in either location)

\*For additional marking information, refer to Application Note AND8002/D.

### ORDERING INFORMATION

See detailed ordering and shipping information in the package dimensions section on page 10 of this data sheet.

## NB6L16



**Figure 1. Pinout (Top View) and Logic Diagram**

**Table 1. PIN DESCRIPTION**

Pin	Name	I/O	Default State	Description
1	NC	–	–	No Connect. The NC pin is electrically connected to the die and <b>MUST</b> be left open.
2	D	LVDS, CML, LVPECL, LVNECL, LVTTTL, LVCMOS Input	LOW	Non-inverted differential clock/data input. Internal 75 k $\Omega$ to $V_{CC}$ and 37.5 k $\Omega$ to $V_{EE}$ .
3	$\bar{D}$	LVDS, CML, LVPECL, LVNECL, LVTTTL, LVCMOS Input	HIGH	Inverted differential clock/data input. Internal 37.5 k $\Omega$ to $V_{CC}$ and 75 k $\Omega$ to $V_{EE}$ .
4	$V_{BB}$	–	–	Internally generated ECL reference voltage supply.
5	$V_{EE}$	–	–	Negative power supply voltage.
6	$\bar{Q}$	ECL Output		Inverted differential ECL output. Typically terminated with 50 $\Omega$ resistor to $V_{CC} - 2.0$ V.
7	Q	ECL Output		Non-inverted differential ECL output. Typically terminated with 50 $\Omega$ resistor to $V_{CC} - 2.0$ V.
8	$V_{CC}$	–	–	Positive power supply voltage.

**Table 2. ATTRIBUTES**

Characteristics	Value
Internal Input Default State Resistor (R1)	37.5 k $\Omega$
Internal Input Default State Resistor (R2)	75 k $\Omega$
ESD Protection	Human Body Model Machine Model Charged Device Model
	> 2 kV > 100 V > 1 kV
Moisture Sensitivity, Indefinite Time Out of Drypack (Note 1)	Level 1
Flammability Rating	Oxygen Index: 28 to 34 UL 94 V-0 @ 1.125 in
Transistor Count	167
Meets or exceeds JEDEC Spec EIA/JESD78 IC Latchup Test	

1. For additional information, see Application Note AND8003/D.

# NB6L16

**Table 3. MAXIMUM RATINGS**

Symbol	Parameter	Condition 1	Condition 2	Rating	Units
$V_{CC}$	PECL Mode Power Supply	$V_{EE} = 0\text{ V}$		3.6	V
$V_{EE}$	NECL Mode Power Supply	$V_{CC} = 0\text{ V}$		-3.6	V
$V_I$	PECL Mode Input Voltage	$V_{EE} = 0\text{ V}$	$V_I \leq V_{CC}$	3.6	V
	NECL Mode Input Voltage	$V_{CC} = 0\text{ V}$	$V_I \geq V_{EE}$	-3.6	V
$I_{out}$	Output Current	Continuous Surge		25	mA
				50	mA
$V_{INPP}$	Differential Input Voltage $ D - \bar{D} $	$V_{CC} - V_{EE} \geq 2.8\text{ V}$ $V_{CC} - V_{EE} < 2.8\text{ V}$		2.8 $ V_{CC} - V_{EE} $	V
$I_{BB}$	$V_{BB}$ Sink/Source			$\pm 0.5$	mA
$T_A$	Operating Temperature Range			-40 to +85	$^{\circ}\text{C}$
$T_{stg}$	Storage Temperature Range			-65 to +150	$^{\circ}\text{C}$
$\theta_{JA}$	Thermal Resistance (Junction-to-Ambient)	0 lfpm	SOIC-8	190	$^{\circ}\text{C}/\text{W}$
		500 lfpm	SOIC-8	130	$^{\circ}\text{C}/\text{W}$
$\theta_{JC}$	Thermal Resistance (Junction-to-Case)	Standard Board	SOIC-8	41 to 44	$^{\circ}\text{C}/\text{W}$
$\theta_{JA}$	Thermal Resistance (Junction-to-Ambient)	0 lfpm	TSSOP-8	185	$^{\circ}\text{C}/\text{W}$
		500 lfpm	TSSOP-8	140	$^{\circ}\text{C}/\text{W}$
$\theta_{JC}$	Thermal Resistance (Junction-to-Case)	Standard Board	TSSOP-8	41 to 44	$^{\circ}\text{C}/\text{W}$
$T_{sol}$	Wave Solder	Standard Pb-Free		$\leq 3\text{ sec @ }248^{\circ}\text{C}$	$^{\circ}\text{C}$
				$\leq 3\text{ sec @ }260^{\circ}\text{C}$	265

Stresses exceeding Maximum Ratings may damage the device. Maximum Ratings are stress ratings only. Functional operation above the Recommended Operating Conditions is not implied. Extended exposure to stresses above the Recommended Operating Conditions may affect device reliability.

# NB6L16

**Table 4. DC CHARACTERISTICS, PECL**  $V_{CC} = 2.5\text{ V}$ ,  $V_{EE} = 0\text{ V}$  (Note 4)

Symbol	Characteristic	-40°C			25°C			85°C			Unit
		Min	Typ	Max	Min	Typ	Max	Min	Typ	Max	
$I_{EE}$	Negative Power Supply Current (Note 5)	10	12	18	10	12	18	10	12	18	mA
$V_{OH}$	Output HIGH Voltage (Note 6)	1350	1450	1550	1400	1500	1600	1450	1550	1650	mV
$V_{OL}$	Output LOW Voltage (Note 6)	565	725	870	630	765	920	690	825	970	mV

**DIFFERENTIAL INPUT DRIVEN SINGLE-ENDED** (Figures 10, 12) (Note 8)

$V_{th}$	Input Threshold Reference Voltage Range (Notes 2, 7)	1125		$V_{CC} - 75$	1125		$V_{CC} - 75$	1125		$V_{CC} - 75$	mV
$V_{IH}$	Single-Ended Input HIGH Voltage	$V_{th} + 75$		$V_{CC}$	$V_{th} + 75$		$V_{CC}$	$V_{th} + 75$		$V_{CC}$	mV
$V_{IL}$	Single-Ended Input LOW Voltage	$V_{EE}$		$V_{th} - 75$	$V_{EE}$		$V_{th} - 75$	$V_{EE}$		$V_{th} - 75$	mV

**DIFFERENTIAL INPUTS DRIVEN DIFFERENTIALLY** (Figures 11, 13) (Note 9)

$V_{IHD}$	Differential Input HIGH Voltage	1200		$V_{CC}$	1200		$V_{CC}$	1200		$V_{CC}$	mV
$V_{ILD}$	Differential Input LOW Voltage	$V_{EE}$		$V_{CC} - 75$	$V_{EE}$		$V_{CC} - 75$	$V_{EE}$		$V_{CC} - 75$	mV
$V_{CMR}$	Input Common Mode Range (Differential Cross-Point Voltage) (Note 3)	950		$V_{CC} - 38$	950		$V_{CC} - 38$	950		$V_{CC} - 38$	mV
$V_{ID}$	Differential Input Voltage ( $V_{IHD} - V_{ILD}$ )	75		2500	75		2500	75		2500	mV
$I_{IH}$	Input HIGH Current	D	50	150		50	150		50	150	$\mu\text{A}$
		$\bar{D}$	10	150		10	150		10	150	
$I_{IL}$	Input LOW Current	D	-150	-5		-150	-5		-150	-5	$\mu\text{A}$
		$\bar{D}$	-150	-30		-150	-30		-150	-30	

NOTE: Device will meet the specifications after thermal equilibrium has been established when mounted in a test socket or printed circuit board with maintained transverse airflow greater than 500 lpm. Electrical parameters are guaranteed only over the declared operating temperature range. Functional operation of the device exceeding these conditions is not implied. Device specification limit values are applied individually under normal operating conditions and not valid simultaneously.

- $V_{th}$  is applied to the complementary input when operating in single-ended mode.
- $V_{CMR}$  minimum varies 1:1 with  $V_{EE}$ ,  $V_{CMR}$  maximum varies 1:1 with  $V_{CC}$ .
- Input and output parameters vary 1:1 with  $V_{CC}$ .  $V_{EE}$  can vary +0.125 V to -1.3 V.
- All input and output pins left open.
- All loading with 50  $\Omega$  to  $V_{CC} - 2.0\text{ V}$ .
- Do not use  $V_{BB}$  as a reference voltage for single-ended PECL signals when operating device at  $V_{CC} - V_{EE} < 3.0\text{ V}$ .
- $V_{th}$ ,  $V_{IH}$ , and  $V_{IL}$  parameters must be complied with simultaneously.
- $V_{IHD}$ ,  $V_{ILD}$ ,  $V_{ID}$  and  $V_{CMR}$  parameters must be complied with simultaneously.

# NB6L16

**Table 5. DC CHARACTERISTICS, PECL**  $V_{CC} = 3.3\text{ V}$ ,  $V_{EE} = 0\text{ V}$  (Note 12)

Symbol	Characteristic	-40°C			25°C			85°C			Unit
		Min	Typ	Max	Min	Typ	Max	Min	Typ	Max	
$I_{EE}$	Negative Power Supply Current (Note 13)	10	12	18	10	12	18	10	12	18	mA
$V_{OH}$	Output HIGH Voltage (Note 14)	2150	2250	2350	2200	2300	2400	2250	2350	2450	mV
$V_{OL}$	Output LOW Voltage (Note 14)	1365	1525	1670	1430	1565	1720	1490	1625	1770	mV

**DIFFERENTIAL INPUT DRIVEN SINGLE-ENDED** (Figures 10, 12) (Note 15)

$V_{th}$	Input Threshold Reference Voltage Range (Note 10)	1125		$V_{CC} - 75$	1125		$V_{CC} - 75$	1125		$V_{CC} - 75$	mV
$V_{IH}$	Single-Ended Input HIGH Voltage	$V_{th} + 75$		$V_{CC}$	$V_{th} + 75$		$V_{CC}$	$V_{th} + 75$		$V_{CC}$	mV
$V_{IL}$	Single-Ended Input LOW Voltage	$V_{EE}$		$V_{th} - 75$	$V_{EE}$		$V_{th} - 75$	$V_{EE}$		$V_{th} - 75$	mV
$V_{BB}$	Output Voltage Reference	1880	1980	2070	1880	1980	2070	1880	1980	2070	mV

**DIFFERENTIAL INPUTS DRIVEN DIFFERENTIALLY** (Figures 11, 13) (Note 16)

$V_{IHD}$	Differential Input HIGH Voltage	1200		$V_{CC}$	1200		$V_{CC}$	1200		$V_{CC}$	mV
$V_{ILD}$	Differential Input LOW Voltage	$V_{EE}$		$V_{CC} - 75$	$V_{EE}$		$V_{CC} - 75$	$V_{EE}$		$V_{CC} - 75$	mV
$V_{CMR}$	Input Common Mode Range (Differential Cross-Point Voltage) (Note 11)	950		$V_{CC} - 38$	950		$V_{CC} - 38$	950		$V_{CC} - 38$	mV
$V_{ID}$	Differential Input Voltage ( $V_{IHD} - V_{ILD}$ )	75		2500	75		2500	75		2500	mV
$I_{IH}$	Input HIGH Current	D D	50 10	150 150		50 10	150 150		50 10	150 150	$\mu\text{A}$
$I_{IL}$	Input LOW Current	D D	-150 -150	-5 -30		-150 -150	-5 -30		-150 -150	-5 -30	$\mu\text{A}$

NOTE: Device will meet the specifications after thermal equilibrium has been established when mounted in a test socket or printed circuit board with maintained transverse airflow greater than 500 lfm. Electrical parameters are guaranteed only over the declared operating temperature range. Functional operation of the device exceeding these conditions is not implied. Device specification limit values are applied individually under normal operating conditions and not valid simultaneously.

10.  $V_{th}$  is applied to the complementary input when operating in single-ended mode.
11.  $V_{CMR}$  minimum varies 1:1 with  $V_{EE}$ ,  $V_{CMR}$  maximum varies 1:1 with  $V_{CC}$ .
12. Input and output parameters vary 1:1 with  $V_{CC}$ .  $V_{EE}$  can vary +0.925 V to -0.5 V.
13. All input and output pins left open.
14. All loading with 50  $\Omega$  to  $V_{CC} - 2.0\text{ V}$ .
15.  $V_{th}$ ,  $V_{IH}$ , and  $V_{IL}$  parameters must be complied with simultaneously.
16.  $V_{IHD}$ ,  $V_{ILD}$ ,  $V_{ID}$  and  $V_{CMR}$  parameters must be complied with simultaneously.

# NB6L16

**Table 6. DC CHARACTERISTICS, NECL**  $V_{CC} = 0\text{ V}$ ,  $V_{EE} = -3.465\text{ V}$  to  $-2.375\text{ V}$  (Note 19)

Symbol	Characteristic	-40°C			25°C			85°C			Unit
		Min	Typ	Max	Min	Typ	Max	Min	Typ	Max	
$I_{EE}$	Negative Power Supply Current (Note 21)	10	12	18	10	12	18	10	12	18	mA
$V_{OH}$	Output HIGH Voltage (Note 20)	-1150	-1050	-950	-1100	-1000	-900	-1050	-950	-850	mV
$V_{OL}$	Output LOW Voltage (Note 20)	-1935	-1775	-1630	-1870	-1735	-1580	-1810	-1675	-1530	mV

**DIFFERENTIAL INPUT DRIVEN SINGLE-ENDED** (Figures 10, 12) (Note 22)

$V_{th}$	Input Threshold Reference Voltage Range (Note 10)	$V_{EE} + 1125$		$V_{CC} - 75$	$V_{EE} + 1125$		$V_{CC} - 75$	$V_{EE} + 1125$		$V_{CC} - 75$	mV
$V_{IH}$	Single-Ended Input HIGH Voltage	$V_{th} + 75$		$V_{CC}$	$V_{th} + 75$		$V_{CC}$	$V_{th} + 75$		$V_{CC}$	mV
$V_{IL}$	Single-Ended Input LOW Voltage	$V_{EE}$		$V_{th} - 75$	$V_{EE}$		$V_{th} - 75$	$V_{EE}$		$V_{th} - 75$	mV
$V_{BB}$	Output Voltage Reference	-1420	-1320	-1230	-1420	-1320	-1230	-1420	-1320	-1230	mV

**DIFFERENTIAL INPUTS DRIVEN DIFFERENTIALLY** (Figures 11, 13) (Note 23)

$V_{IHD}$	Differential Input HIGH Voltage	$V_{EE} + 1200$		$V_{CC}$	$V_{EE} + 1200$		$V_{CC}$	$V_{EE} + 1200$		$V_{CC}$	mV
$V_{ILD}$	Differential Input LOW Voltage	$V_{EE}$		$V_{CC} - 75$	$V_{EE}$		$V_{CC} - 75$	$V_{EE}$		$V_{CC} - 75$	mV
$V_{CMR}$	Input Common Mode Range (Differential Cross-Point Voltage) (Note 11)	$V_{EE} + 950$		$V_{CC} - 38$	$V_{EE} + 950$		$V_{CC} - 38$	$V_{EE} + 950$		$V_{CC} - 38$	mV
$V_{ID}$	Differential Input Voltage ( $V_{IHD} - V_{ILD}$ )	75		2500	75		2500	75		2500	mV
$I_{IH}$	Input HIGH Current	$\frac{D}{D}$	50 10	150 150		50 10	150 150		50 10	150 150	$\mu\text{A}$
$I_{IL}$	Input LOW Current	$\frac{D}{D}$	-150 -150	-5 -30		-150 -150	-5 -30		-150 -150	-5 -30	$\mu\text{A}$

NOTE: Device will meet the specifications after thermal equilibrium has been established when mounted in a test socket or printed circuit board with maintained transverse airflow greater than 500 lpm. Electrical parameters are guaranteed only over the declared operating temperature range. Functional operation of the device exceeding these conditions is not implied. Device specification limit values are applied individually under normal operating conditions and not valid simultaneously.

17.  $V_{th}$  is applied to the complementary input when operating in single-ended mode.

18.  $V_{CMR}$  minimum varies 1:1 with  $V_{EE}$ ,  $V_{CMR}$  maximum varies 1:1 with  $V_{CC}$ .

19. Input and output parameters vary 1:1 with  $V_{CC}$ .

20. All loading with  $50\ \Omega$  to  $V_{CC} - 2.0\text{ V}$ .

21. All input and output pins left open.

22.  $V_{th}$ ,  $V_{IH}$ , and  $V_{IL}$  parameters must be complied with simultaneously.

23.  $V_{IHD}$ ,  $V_{ILD}$ ,  $V_{ID}$  and  $V_{CMR}$  parameters must be complied with simultaneously.

# NB6L16

**Table 7. AC CHARACTERISTICS**  $V_{CC} = 0\text{ V}$ ;  $V_{EE} = -3.465\text{ V}$  to  $-2.375\text{ V}$  or  $V_{CC} = 2.375\text{ V}$  to  $3.465\text{ V}$ ;  $V_{EE} = 0\text{ V}$  (Note 24)

Symbol	Characteristic	-40°C			25°C			85°C			Unit
		Min	Typ	Max	Min	Typ	Max	Min	Typ	Max	
$V_{OUTPP}$	Output Voltage Amplitude (See Figures 2 & 3) $f_{in} < 3\text{ GHz}$ $f_{in} < 6\text{ GHz}$	500 270	700 350		500 270	700 350		500 270	700 300		mV
$f_{DATA}$	Maximum Operating Data Rate	6									Gb/s
$t_{PLH}$ , $t_{PHL}$	Propagation Delay to Output Differential @ 1 GHz	80	130	180	80	130	180	85	135	185	ps
$t_{SKEW}$	Duty Cycle Skew (Note 25) Device-to-Device Skew		3 30	25 60		3 30	25 60		3 30	25 60	ps
$t_{JITTER}$	RMS Random Clock Jitter (Note 26) Peak-to-Peak Data Dependent Jitter (Note 27) $f_{in} < 6\text{ GHz}$ $f_{in} < 6\text{ Gb/s}$		0.2 2	1 12		0.2 2	1 12		0.2 2	1 12	ps
$V_{INPP}$	Input Voltage Swing / Sensitivity (Differential Configuration) (Note 28)	75	700	2500	75	700	2500	75	700	2500	mV
$t_r$ $t_f$	Output Rise/Fall Times (20% – 80%) Q, $\bar{Q}$	30	70	120	30	70	120	30	70	120	ps

NOTE: Device will meet the specifications after thermal equilibrium has been established when mounted in a test socket or printed circuit board with maintained transverse airflow greater than 500 lfm. Electrical parameters are guaranteed only over the declared operating temperature range. Functional operation of the device exceeding these conditions is not implied. Device specification limit values are applied individually under normal operating conditions and not valid simultaneously.

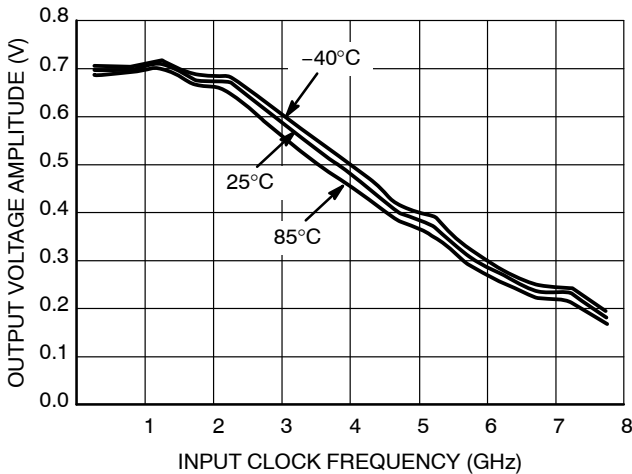
24. Measured using a 800 mV source, 50% duty cycle clock source. All loading with  $50\ \Omega$  to  $V_{CC}$ . Input edge rates 40 ps (20% – 80%).

25. See Figure 9  $t_{skew} = |t_{PLH} - t_{PHL}|$  for a nominal 50% differential clock input waveform. Skew is measured between outputs under identical transitions and conditions @ 1 GHz.

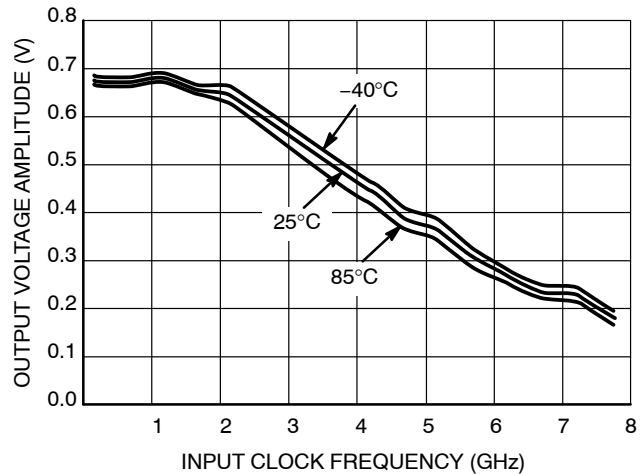
26. Additive RMS jitter with 50% duty cycle clock signal at 6 GHz.

27. Additive Peak-to-Peak data dependent jitter with NRZ PRBS  $2^{23}-1$  data rate at 6 Gb/s.

28.  $V_{INPP(max)}$  cannot exceed  $V_{CC} - V_{EE}$ . (Applicable only when  $V_{CC} - V_{EE} < 2500\text{ mV}$ ). Input voltage swing is a single-ended measurement operating in the differential mode.

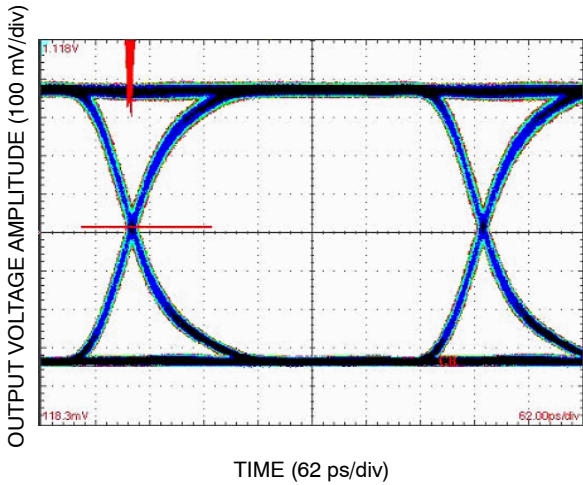


**Figure 2. Output Voltage Amplitude ( $V_{OUTPP}$ ) versus Input Clock Frequency ( $f_{IN}$ ) and Temperature at  $V_{CC} - V_{EE} = 3.3\text{ V}$**

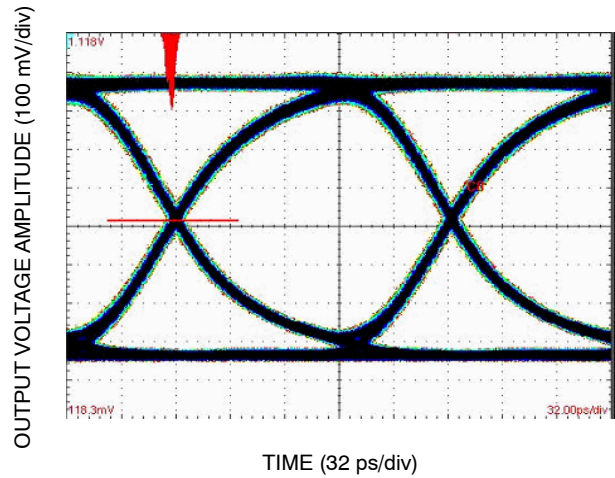


**Figure 3. Output Voltage Amplitude ( $V_{OUTPP}$ ) versus Input Clock Frequency ( $f_{IN}$ ) and Temperature at  $V_{CC} - V_{EE} = 2.5\text{ V}$**

# NB6L16

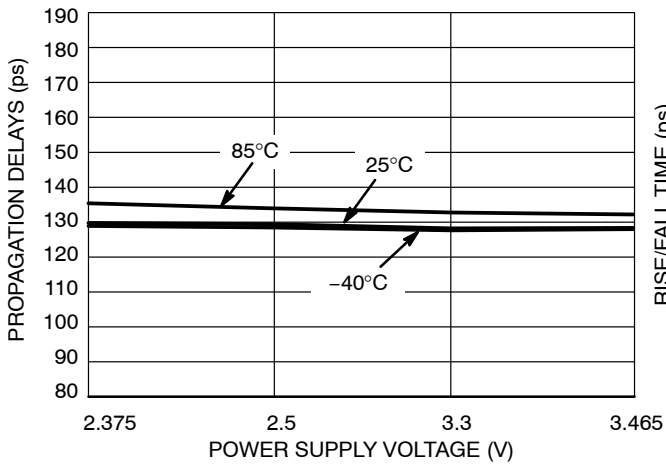


**Figure 4. Typical Output Waveform at 2.488 Gb/s with PRBS 2<sup>23</sup>-1 (Total System Pk-Pk Jitter is 16 ps. Device Pk-Pk Jitter Contribution is 3 ps)**

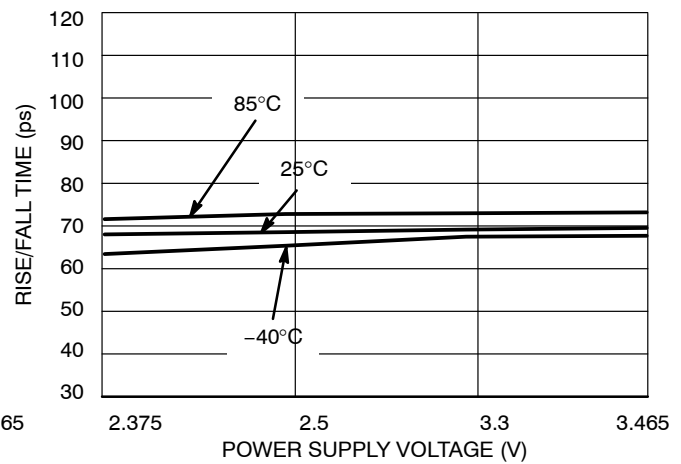


**Figure 5. Typical Output Waveform at 6.125 Gb/s with PRBS 2<sup>23</sup>-1 (Total System Pk-Pk Jitter is 17 ps. Device Pk-Pk Jitter Contribution is 4 ps)**

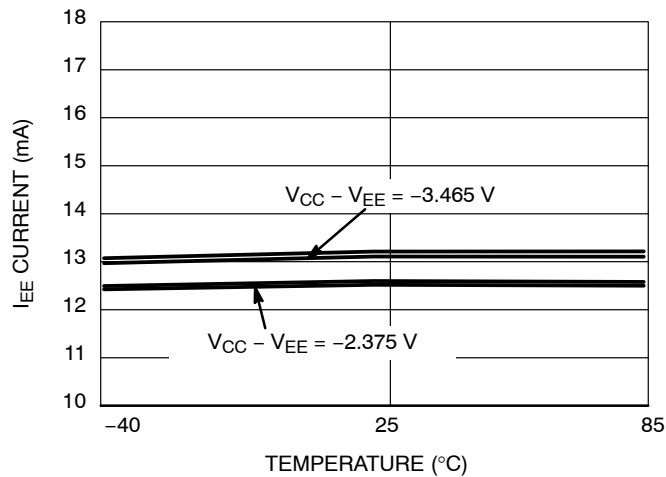
NOTE:  $V_{CC} - V_{EE} = 3.3 \text{ V}$ ;  $V_{IN} = 700 \text{ mV}$ ;  $T_A = 25^\circ\text{C}$ .



**Figure 6. Propagation Delay versus Power Supply Voltage and Temperature**



**Figure 7. Rise/Fall Time versus Power Supply Voltage and Temperature**



**Figure 8.  $I_{EE}$  Current versus Temperature and Power Supply Voltage**



# NB6L16

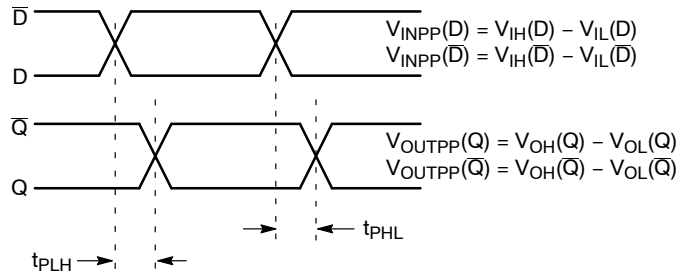


Figure 9. AC Reference Measurement

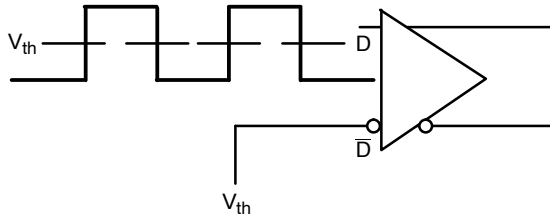


Figure 10. Differential Input Driven Single-Ended

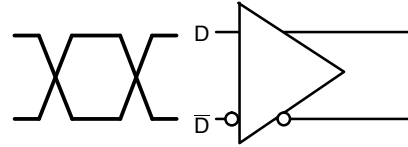


Figure 11. Differential Inputs Driven Differentially

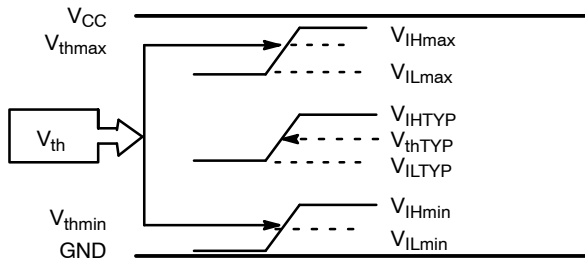


Figure 12.  $V_{th}$  Diagram

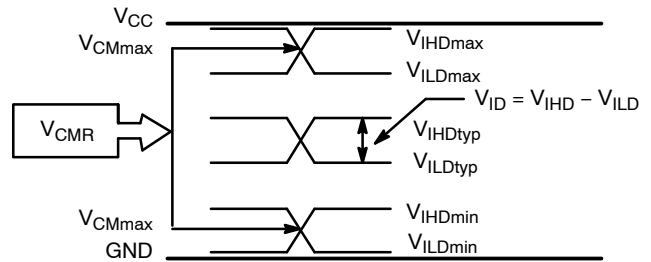


Figure 13.  $V_{CMR}$  Diagram

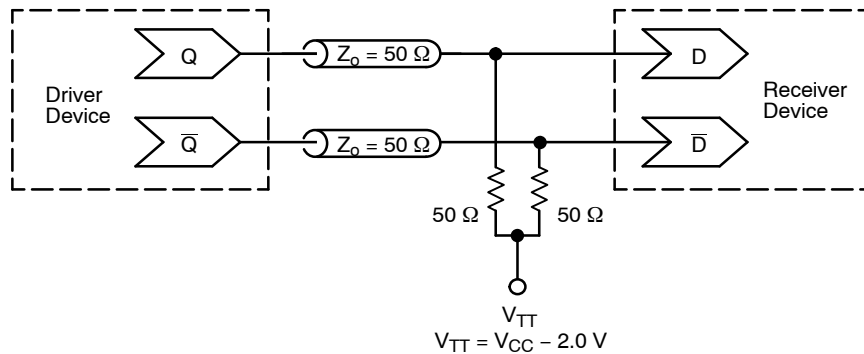


Figure 14. Typical Termination for Output Driver and Device Evaluation (See Application Note AND8020/D – Termination of ECL Logic Devices.)

# NB6L16

## ORDERING INFORMATION

Device	Package	Shipping <sup>†</sup>
NB6L16D	SOIC-8	98 Units / Rail
NB6L16DG	SOIC-8 (Pb-Free)	98 Units / Rail
NB6L16DR2	SOIC-8	2500 / Tape & Reel
NB6L16DR2G	SOIC-8 (Pb-Free)	2500 / Tape & Reel
NB6L16DT	TSSOP-8	100 Units / Rail
NB6L16DTG	TSSOP-8 (Pb-Free)	100 Units / Rail
NB6L16DTR2	TSSOP-8	2500 / Tape & Reel
NB6L16DTR2G	TSSOP-8 (Pb-Free)	2500 / Tape & Reel

<sup>†</sup>For information on tape and reel specifications, including part orientation and tape sizes, please refer to our Tape and Reel Packaging Specifications Brochure, BRD8011/D.

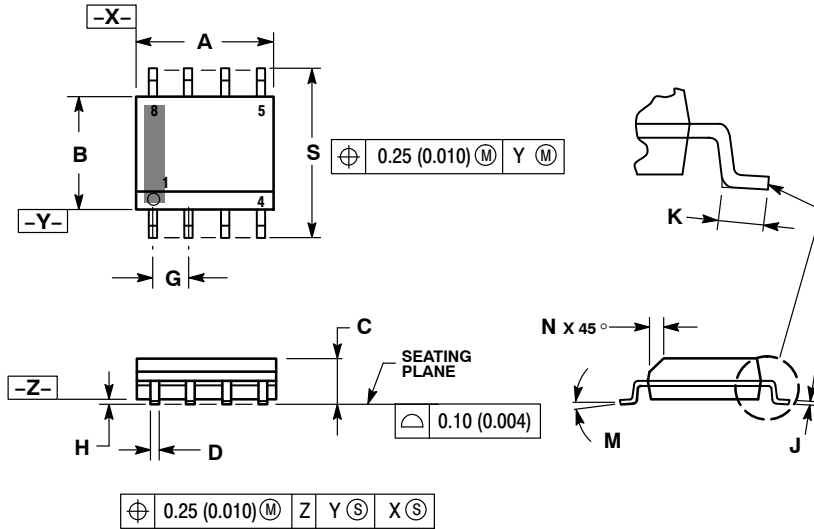
### Resource Reference of Application Notes

- AN1405/D** – ECL Clock Distribution Techniques
- AN1406/D** – Designing with PECL (ECL at +5.0 V)
- AN1503/D** – ECLinPS™ I/O SPICE Modeling Kit
- AN1504/D** – Metastability and the ECLinPS Family
- AN1568/D** – Interfacing Between LVDS and ECL
- AN1672/D** – The ECL Translator Guide
- AND8001/D** – Odd Number Counters Design
- AND8002/D** – Marking and Date Codes
- AND8020/D** – Termination of ECL Logic Devices
- AND8066/D** – Interfacing with ECLinPS
- AND8090/D** – AC Characteristics of ECL Devices

# NB6L16

## PACKAGE DIMENSIONS

SOIC-8 NB  
CASE 751-07  
ISSUE AJ

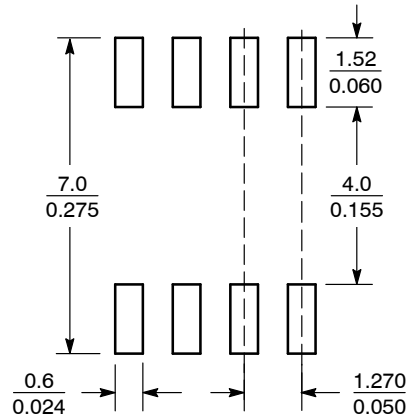


### NOTES:

1. DIMENSIONING AND TOLERANCING PER ANSI Y14.5M, 1982.
2. CONTROLLING DIMENSION: MILLIMETER.
3. DIMENSION A AND B DO NOT INCLUDE MOLD PROTRUSION.
4. MAXIMUM MOLD PROTRUSION 0.15 (0.006) PER SIDE.
5. DIMENSION D DOES NOT INCLUDE DAMBAR PROTRUSION. ALLOWABLE DAMBAR PROTRUSION SHALL BE 0.127 (0.005) TOTAL IN EXCESS OF THE D DIMENSION AT MAXIMUM MATERIAL CONDITION.
6. 751-01 THRU 751-06 ARE OBSOLETE. NEW STANDARD IS 751-07.

DIM	MILLIMETERS		INCHES	
	MIN	MAX	MIN	MAX
A	4.80	5.00	0.189	0.197
B	3.80	4.00	0.150	0.157
C	1.35	1.75	0.053	0.069
D	0.33	0.51	0.013	0.020
G	1.27 BSC		0.050 BSC	
H	0.10	0.25	0.004	0.010
J	0.19	0.25	0.007	0.010
K	0.40	1.27	0.016	0.050
M	0°	8°	0°	8°
N	0.25	0.50	0.010	0.020
S	5.80	6.20	0.228	0.244

### SOLDERING FOOTPRINT\*



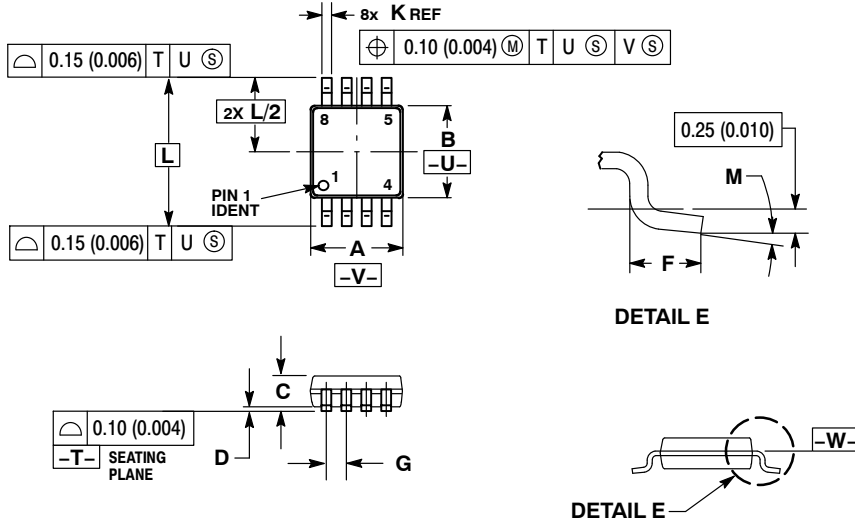
SCALE 6:1  $\left(\frac{\text{mm}}{\text{inches}}\right)$

\*For additional information on our Pb-Free strategy and soldering details, please download the ON Semiconductor Soldering and Mounting Techniques Reference Manual, SOLDERRM/D.

# NB6L16

## PACKAGE DIMENSIONS

### TSSOP-8 DT SUFFIX PLASTIC TSSOP PACKAGE CASE 948R-02 ISSUE A



#### NOTES:

1. DIMENSIONING AND TOLERANCING PER ANSI Y14.5M, 1982.
2. CONTROLLING DIMENSION: MILLIMETER.
3. DIMENSION A DOES NOT INCLUDE MOLD FLASH. PROTRUSIONS OR GATE BURRS. MOLD FLASH OR GATE BURRS SHALL NOT EXCEED 0.15 (0.006) PER SIDE.
4. DIMENSION B DOES NOT INCLUDE INTERLEAD FLASH OR PROTRUSION. INTERLEAD FLASH OR PROTRUSION SHALL NOT EXCEED 0.25 (0.010) PER SIDE.
5. TERMINAL NUMBERS ARE SHOWN FOR REFERENCE ONLY.
6. DIMENSION A AND B ARE TO BE DETERMINED AT DATUM PLANE -W-.

DIM	MILLIMETERS		INCHES	
	MIN	MAX	MIN	MAX
A	2.90	3.10	0.114	0.122
B	2.90	3.10	0.114	0.122
C	0.80	1.10	0.031	0.043
D	0.05	0.15	0.002	0.006
F	0.40	0.70	0.016	0.028
G	0.65 BSC		0.026 BSC	
K	0.25	0.40	0.010	0.016
L	4.90 BSC		0.193 BSC	
M	0°	6°	0°	6°

ECLinPS is a trademark of Semiconductor Components Industries, LLC.

ON Semiconductor and are registered trademarks of Semiconductor Components Industries, LLC (SCILLC). SCILLC reserves the right to make changes without further notice to any products herein. SCILLC makes no warranty, representation or guarantee regarding the suitability of its products for any particular purpose, nor does SCILLC assume any liability arising out of the application or use of any product or circuit, and specifically disclaims any and all liability, including without limitation special, consequential or incidental damages. "Typical" parameters which may be provided in SCILLC data sheets and/or specifications can and do vary in different applications and actual performance may vary over time. All operating parameters, including "Typicals" must be validated for each customer application by customer's technical experts. SCILLC does not convey any license under its patent rights nor the rights of others. SCILLC products are not designed, intended, or authorized for use as components in systems intended for surgical implant into the body, or other applications intended to support or sustain life, or for any other application in which the failure of the SCILLC product could create a situation where personal injury or death may occur. Should Buyer purchase or use SCILLC products for any such unintended or unauthorized application, Buyer shall indemnify and hold SCILLC and its officers, employees, subsidiaries, affiliates, and distributors harmless against all claims, costs, damages, and expenses, and reasonable attorney fees arising out of, directly or indirectly, any claim of personal injury or death associated with such unintended or unauthorized use, even if such claim alleges that SCILLC was negligent regarding the design or manufacture of the part. SCILLC is an Equal Opportunity/Affirmative Action Employer. This literature is subject to all applicable copyright laws and is not for resale in any manner.

#### PUBLICATION ORDERING INFORMATION

**LITERATURE FULFILLMENT:**  
Literature Distribution Center for ON Semiconductor  
P.O. Box 5163, Denver, Colorado 80217 USA  
**Phone:** 303-675-2175 or 800-344-3860 Toll Free USA/Canada  
**Fax:** 303-675-2176 or 800-344-3867 Toll Free USA/Canada  
**Email:** orderlit@onsemi.com

**N. American Technical Support:** 800-282-9855 Toll Free  
USA/Canada  
**Europe, Middle East and Africa Technical Support:**  
Phone: 421 33 790 2910  
**Japan Customer Focus Center**  
Phone: 81-3-5773-3850

**ON Semiconductor Website:** [www.onsemi.com](http://www.onsemi.com)  
**Order Literature:** <http://www.onsemi.com/orderlit>  
For additional information, please contact your local Sales Representative

NB6L16/D