

### General Description

The ICS8534-01 is a low skew, 1-to-22 Differential-to-3.3V LVPECL Fanout Buffer. The ICS8534-01 has two selectable clock inputs. The CLK, nCLK pair can accept most standard differential input levels. The PCLK, nPCLK pair can accept LVPECL, CML, or SSTL input levels. The device is internally synchronized to eliminate runt pulses on the outputs during asynchronous assertion/deassertion of the OE pin. The ICS8534-01's low output and part-to-part skew characteristics make it ideal for workstation, server, and other high performance clock distribution applications.

### Features

- Twenty-two differential LVPECL outputs
- Selectable differential CLK, nCLK or LVPECL clock inputs
- CLK, nCLK pair can accept the following differential input levels: LVPECL, LVDS, LVHSTL, HCSL, SSTL
- PCLK, nPCLK supports the following input levels: LVPECL, CML, SSTL
- Maximum output frequency: 500MHz
- Output skew: 100ps (maximum)
- Translates any single-ended input signal (LVCMOS, LVTTTL, GTL) to LVPECL levels with resistor bias on nCLK input
- Additive phase jitter, RMS): 0.15ps (typical)
- Full 3.3V supply mode
- 0°C to 85°C ambient operating temperature
- Available in both standard (RoHS 5) and lead-free (RoHS 6) packages

### Block Diagram

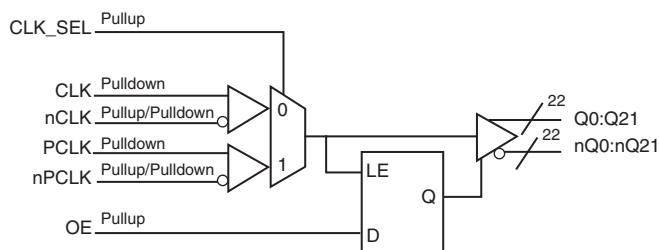

### Pin Assignment



### ICS8534-01

64-Lead TQFP E-Pad

10mm x 10mm x 1.0mm package body

**Y package**

Top View

**Table 1. Pin Descriptions**

| Number                        | Name             | Type   |                     | Description   |
|-------------------------------|------------------|--------|---------------------|---|
| 1, 16, 17, 32, 33, 48, 49, 64 | V <sub>CCO</sub> | Power  |                     | Output supply pins for LVPECL outputs.  |
| 2, 3, 12, 13                  | nc               | Unused |                     | No connect.   |
| 4                             | V <sub>CC</sub>  | Power  |                     | Core supply pin for LVPECL outputs.   |
| 5                             | CLK              | Input  | Pulldown            | Non-inverting differential clock input.   |
| 6                             | nCLK             | Input  | Pullup/<br>Pulldown | Inverting differential clock input. Pulled to $\frac{2}{3} V_{CC}$ .  |
| 7                             | CLK_SEL          | Input  | Pullup              | Clock select input. When HIGH, selects PCLK, nPCLK inputs. When LOW, selects CLK, nCLK inputs. LVCMOS / LVTTTL interface levels.  |
| 8                             | PCLK             | Input  | Pulldown            | Non-inverting differential LVPECL clock input.  |
| 9                             | nPCLK            | Input  | Pullup/<br>Pulldown | Inverting differential LVPECL clock input. Pulled to $\frac{2}{3} V_{CC}$ .   |
| 10                            | V <sub>EE</sub>  | Power  |                     | Negative supply pin.  |
| 11                            | OE               | Input  | Pullup              | Output enable. When logic HIGH, the outputs are enabled (default). When logic LOW, the outputs are disabled and drive differential low: Qx = LOW, nQx = HIGH. LVCMOS / LVTTTL interface levels. |
| 14, 15                        | nQ21, Q21        | Output |                     | Differential clock outputs. LVPECL interface Levels.  |
| 18, 19                        | nQ20, Q20        | Output |                     | Differential clock outputs. LVPECL interface Levels.  |
| 20, 21                        | nQ19, Q19        | Output |                     | Differential clock outputs. LVPECL interface Levels.  |
| 22, 23                        | nQ18, Q18        | Output |                     | Differential clock outputs. LVPECL interface Levels.  |
| 24, 25                        | nQ17, Q17        | Output |                     | Differential clock outputs. LVPECL interface Levels.  |
| 26, 27                        | nQ16, Q16        | Output |                     | Differential clock outputs. LVPECL interface Levels.  |
| 28, 29                        | nQ15, Q15        | Output |                     | Differential clock outputs. LVPECL interface Levels.  |
| 30, 31                        | nQ14, Q14        | Output |                     | Differential clock outputs. LVPECL interface Levels.  |
| 34, 35                        | nQ13, Q13        | Output |                     | Differential clock outputs. LVPECL interface Levels.  |
| 36, 37                        | nQ12, Q12        | Output |                     | Differential clock outputs. LVPECL interface Levels.  |
| 38, 39                        | nQ11, Q11        | Output |                     | Differential clock outputs. LVPECL interface Levels.  |
| 40, 41                        | nQ10, Q10        | Output |                     | Differential clock outputs. LVPECL interface Levels.  |
| 42, 43                        | nQ9, Q9          | Output |                     | Differential clock outputs. LVPECL interface Levels.  |
| 44, 45                        | nQ8, Q8          | Output |                     | Differential clock outputs. LVPECL interface Levels.  |
| 46, 47                        | nQ7, Q7          | Output |                     | Differential clock outputs. LVPECL interface Levels.  |
| 50, 51                        | nQ6, Q6          | Output |                     | Differential clock outputs. LVPECL interface Levels.  |
| 52, 53                        | nQ5, Q5          | Output |                     | Differential clock outputs. LVPECL interface Levels.  |
| 54, 55                        | nQ4, Q4          | Output |                     | Differential clock outputs. LVPECL interface Levels.  |
| 56, 57                        | nQ3, Q3          | Output |                     | Differential clock outputs. LVPECL interface Levels.  |
| 58, 59                        | nQ2, Q2          | Output |                     | Differential clock outputs. LVPECL interface Levels.  |
| 60, 61                        | nQ1, Q1          | Output |                     | Differential clock outputs. LVPECL interface Levels.  |
| 62, 63                        | nQ0, Q0          | Output |                     | Differential clock outputs. LVPECL interface Levels.  |

NOTE: Pullup and Pulldown refer to internal input resistors. See Table 2, *Pin Characteristics*, for typical values.

## Table 2. Pin Characteristics

| Symbol         | Parameter               | Test Conditions | Minimum | Typical | Maximum | Units     |
|----------------|-------------------------|-----------------|---------|---------|---------|-----------|
| $C_{IN}$       | Input Capacitance       |                 |         | 4       |         | pF        |
| $R_{PULLUP}$   | Input Pullup Resistor   |                 |         | 37      |         | $k\Omega$ |
| $R_{PULLDOWN}$ | Input Pulldown Resistor |                 |         | 75      |         | $k\Omega$ |

## Function Table

Table 3. Control Input Function Table.

| Inputs |         | Outputs |          |
|--------|---------|---------|----------|
| OE     | CLK_SEL | Q0:Q21  | nQ0:nQ21 |
| 0      | 0       | LOW     | HIGH     |
| 0      | 1       | LOW     | HIGH     |
| 1      | 0       | CLK     | nCLK     |
| 1      | 1       | PCLK    | nPCLK    |

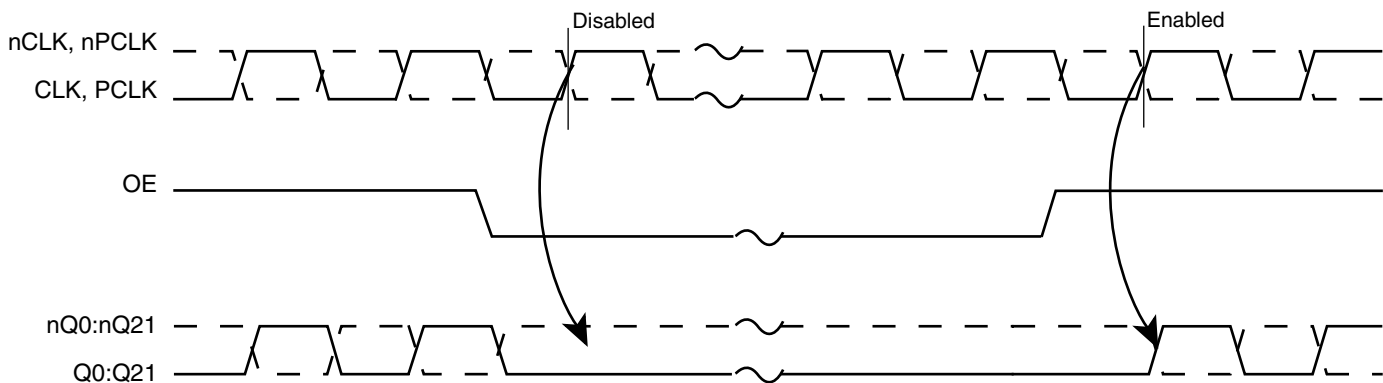

Figure 1. OE Timing Diagram

## Absolute Maximum Ratings

NOTE: Stresses beyond those listed under *Absolute Maximum Ratings* may cause permanent damage to the device. These ratings are stress specifications only. Functional operation of product at these conditions or any conditions beyond those listed in the *DC Characteristics* or *AC Characteristics* is not implied. Exposure to absolute maximum rating conditions for extended periods may affect product reliability.

| Item   | Rating                   |
|--|--------------------------|
| Supply Voltage, $V_{CC}$                                       | 4.6V                     |
| Inputs, $V_I$  | -0.5V to $V_{CC} + 0.5V$ |
| Outputs, $I_O$ (LVPECL)<br>Continuous Current<br>Surge Current | 50mA<br>100mA            |
| Package Thermal Impedance, $\theta_{JA}$                       | 22.3°C/W (0 lfpm)        |
| Storage Temperature, $T_{STG}$                                 | -65°C to 150°C           |

## DC Electrical Characteristics

**Table 4A. Power Supply DC Characteristics,  $V_{CC} = V_{CCO} = 3.3V \pm 5\%$ ,  $V_{EE} = 0V$ ,  $T_A = 0^\circ C$  to  $85^\circ C$**

| Symbol    | Parameter             | Test Conditions | Minimum | Typical | Maximum | Units |
|-----------|-----------------------|-----------------|---------|---------|---------|-------|
| $V_{CC}$  | Core Supply Voltage   |                 | 3.135   | 3.3     | 3.465   | V     |
| $V_{CCO}$ | Output Supply Voltage |                 | 3.135   | 3.3     | 3.465   | V     |
| $I_{EE}$  | Power Supply Current  |                 |         |         | 230     | mA    |

**Table 4B. LVCMOS/LVTTL DC Characteristics,  $V_{CC} = V_{CCO} = 3.3V \pm 5\%$ ,  $V_{EE} = 0V$ ,  $T_A = 0^\circ C$  to  $85^\circ C$**

| Symbol   | Parameter          | Test Conditions                               | Minimum | Typical | Maximum        | Units   |
|----------|--------------------|---|---------|---------|----------------|---------|
| $V_{IH}$ | Input High Voltage |   | 2       |         | $V_{CC} + 0.3$ | V       |
| $V_{IL}$ | Input Low Voltage  |   | -0.3    |         | 0.8            | V       |
| $I_{IH}$ | Input High Current | OE, CLK_SEL<br>$V_{CC} = V_{IN} = 3.465V$     |         |         | 5              | $\mu A$ |
| $I_{IL}$ | Input Low Current  | OE, CLK_SEL<br>$V_{CC} = 3.465V, V_{IN} = 0V$ | -150    |         |                | $\mu A$ |

**Table 4C. Differential DC Characteristics,  $V_{CC} = V_{CCO} = 3.3V \pm 5\%$ ,  $V_{EE} = 0V$ ,  $T_A = 0^\circ C$  to  $85^\circ C$** 

| Symbol    | Parameter                            | Test Conditions | Minimum                        | Typical | Maximum         | Units   |
|-----------|--------------------------------------|-----------------|--------------------------------|---------|-----------------|---------|
| $I_{IH}$  | Input High Current                   | CLK             | $V_{CC} = V_{IN} = 3.465V$     |         | 150             | $\mu A$ |
|           |                                      | nCLK            | $V_{CC} = V_{IN} = 3.465V$     |         | 5               | $\mu A$ |
| $I_{IL}$  | Input Low Current                    | CLK             | $V_{CC} = 3.465V, V_{IN} = 0V$ | -5      |                 | $\mu A$ |
|           |                                      | nCLK            | $V_{CC} = 3.465V, V_{IN} = 0V$ | -150    |                 | $\mu A$ |
| $V_{PP}$  | Peak-to-Peak Voltage; NOTE 1         |                 | 0.15                           |         | 1.3             | V       |
| $V_{CMR}$ | Common Mode Input Voltage; NOTE 1, 2 |                 | $V_{EE} + 0.5$                 |         | $V_{CC} - 0.85$ | V       |

NOTE 1:  $V_{IL}$  should not be less than -0.3V.NOTE 2: Common mode input voltage is defined as  $V_{IH}$ .**Table 4C. LVPECL DC Characteristics,  $V_{CC} = V_{CCO} = 3.3V \pm 5\%$ ,  $V_{EE} = 0V$ ,  $T_A = 0^\circ C$  to  $85^\circ C$** 

| Symbol      | Parameter                         | Test Conditions | Minimum                        | Typical | Maximum         | Units   |
|-------------|-----------------------------------|-----------------|--------------------------------|---------|-----------------|---------|
| $I_{IH}$    | Input High Current                | PCLK            | $V_{CC} = V_{IN} = 3.465V$     |         | 150             | $\mu A$ |
|             |                                   | nPCLK           | $V_{CC} = V_{IN} = 3.465V$     |         | 5               | $\mu A$ |
| $I_{IL}$    | Input Low Current                 | PCLK            | $V_{CC} = 3.465V, V_{IN} = 0V$ | -5      |                 | $\mu A$ |
|             |                                   | nPCLK           | $V_{CC} = 3.465V, V_{IN} = 0V$ | -150    |                 | $\mu A$ |
| $V_{PP}$    | Peak-to-Peak Voltage              |                 | 0.3                            |         | 1.0             | V       |
| $V_{CMR}$   | Common Mode Input Voltage; NOTE 1 |                 | $V_{EE} + 1.5$                 |         | $V_{CC}$        | V       |
| $V_{OH}$    | Output High Voltage; NOTE 2       |                 | $V_{CCO} - 1.4$                |         | $V_{CCO} - 0.9$ | V       |
| $V_{OL}$    | Output Low Voltage; NOTE 2        |                 | $V_{CCO} - 2.0$                |         | $V_{CCO} - 1.7$ | V       |
| $V_{SWING}$ | Peak-to-Peak Output Voltage Swing |                 | 0.6                            |         | 1.0             | V       |

NOTE 1: Common mode input voltage is defined as  $V_{IH}$ .NOTE 2: Outputs terminated with  $50\Omega$  to  $V_{CCO} - 2V$ .

## AC Electrical Characteristics

**Table 5.**  $V_{CC} = V_{CCO} = 3.3V \pm 5\%$ ,  $V_{EE} = 0V$ ,  $T_A = 0^\circ C$  to  $85^\circ C$

| Symbol       | Parameter   | Test Conditions                  | Minimum | Typical | Maximum | Units |
|--------------|---|----------------------------------|---------|---------|---------|-------|
| $f_{OUT}$    | Output Frequency  |                                  |         |         | 500     | MHz   |
| $t_{PD}$     | Propagation Delay; NOTE 1   | $f \leq 500MHz$                  | 2.0     |         | 3.0     | ns    |
| $t_{sk(o)}$  | Output Skew; NOTE 2, 3  |                                  |         |         | 100     | ps    |
| $t_{sk(pp)}$ | Part-to-Part Skew; NOTE 3, 4  |                                  |         |         | 700     | ps    |
| $t_{jit}$    | Buffer Additive Phase Jitter, RMS, refer to Additive Phase Jitter section; NOTE 5 | Integration Range: 12kHz - 20MHz |         | 0.15    |         | ps    |
| $t_R / t_F$  | Output Rise/ Fall Time  | 20% to 80%                       | 200     |         | 700     | ps    |
| $t_S$        | Setup Time  |                                  | 1       |         |         | ns    |
| $t_H$        | Hold Time   |                                  | 0.5     |         |         | ns    |
| odc          | Output Duty Cycle   | $f \leq 266MHz$                  | 48      |         | 52      | %     |
|              |   | $266 < f \leq 500MHz$            | 46      |         | 54      | %     |

All parameters measured at  $f_{OUT}$  unless noted otherwise.

Special thermal considerations may be required. See Applications Section.

NOTE 1: Measured from the differential input crossing point to the differential output crossing point.

NOTE 2: Defined as skew between outputs at the same supply voltage and with equal load conditions.

NOTE 3: This parameter is defined in accordance with JEDEC Standard 65. Measured at the output differential cross points.

NOTE 4: Defined as skew between outputs on different devices operating at the same supply voltages and with equal load conditions at the same temperature. Using the same type of inputs on each device, the outputs are measured at the differential cross points.

NOTE 5: Driving only one input clock.

## Additive Phase Jitter

The spectral purity in a band at a specific offset from the fundamental compared to the power of the fundamental is called the **dBc Phase Noise**. This value is normally expressed using a Phase noise plot and is most often the specified plot in many applications. Phase noise is defined as the ratio of the noise power present in a 1Hz band at a specified offset from the fundamental frequency to the power value of the fundamental. This ratio is expressed in decibels (dBm) or a ratio

of the power in the 1Hz band to the power in the fundamental. When the required offset is specified, the phase noise is called a **dBc** value, which simply means dBm at a specified offset from the fundamental. By investigating jitter in the frequency domain, we get a better understanding of its effects on the desired application over the entire time record of the signal. It is mathematically possible to calculate an expected bit error rate given a phase noise plot.

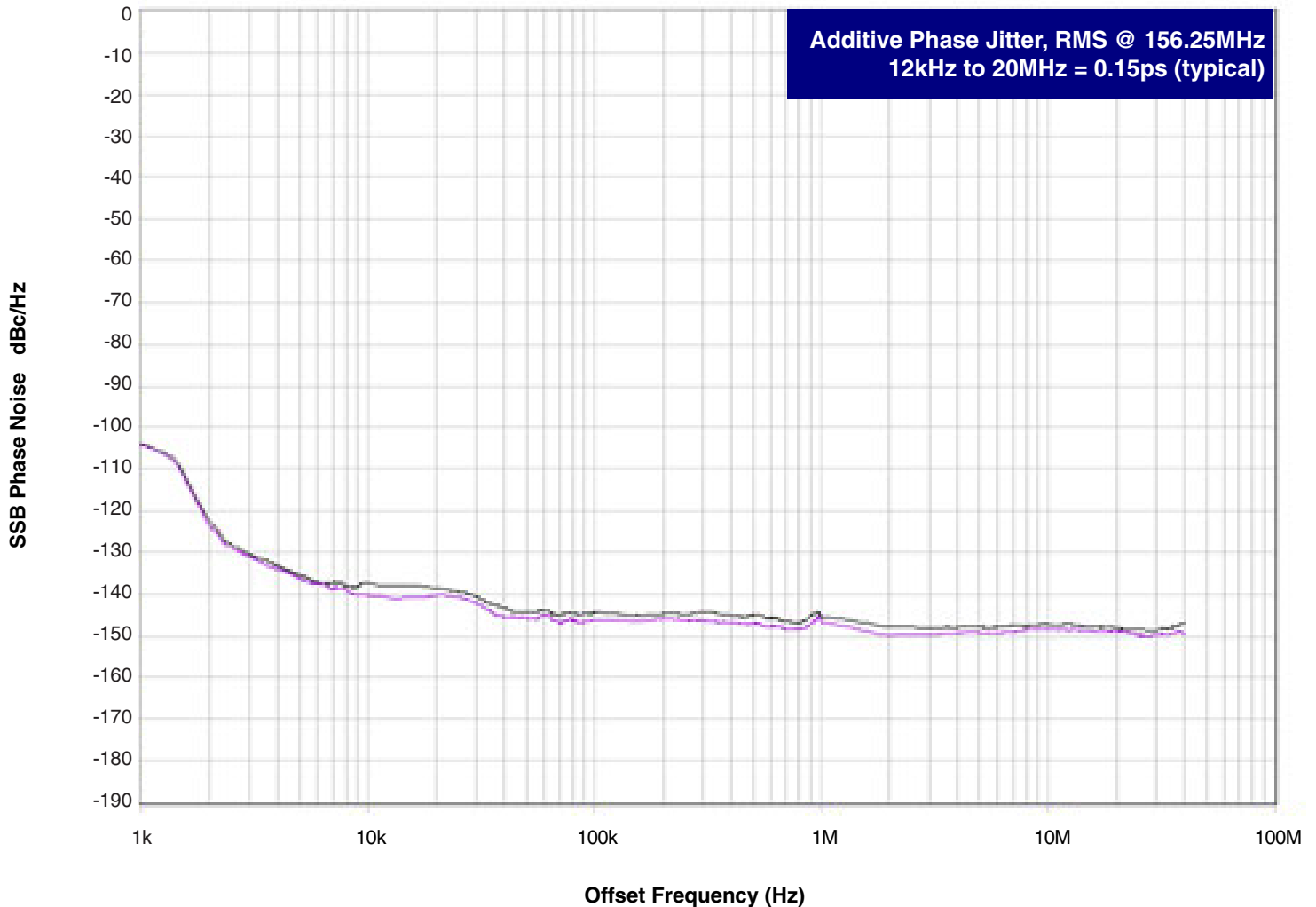

As with most timing specifications, phase noise measurements has issues relating to the limitations of the equipment. Often the noise floor of the equipment is higher than the noise floor of the device. This is illustrated above. The device meets the noise floor of what is

shown, but can actually be lower. The phase noise is dependant on the input source and measurement equipment.

### Parameter Measurement Information

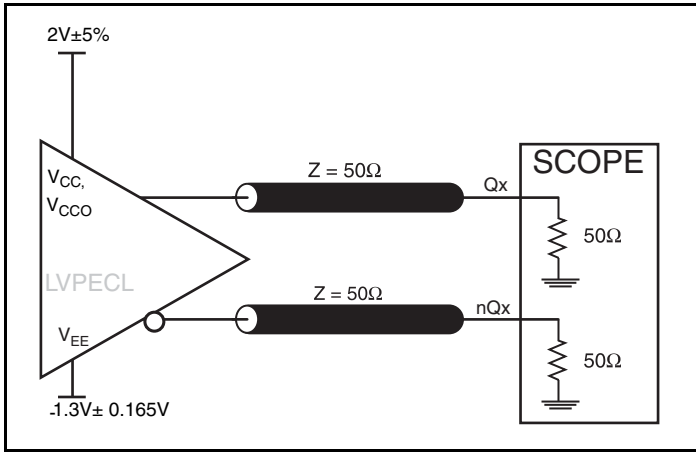

3.3V LVPECL Output Load AC Test Circuit

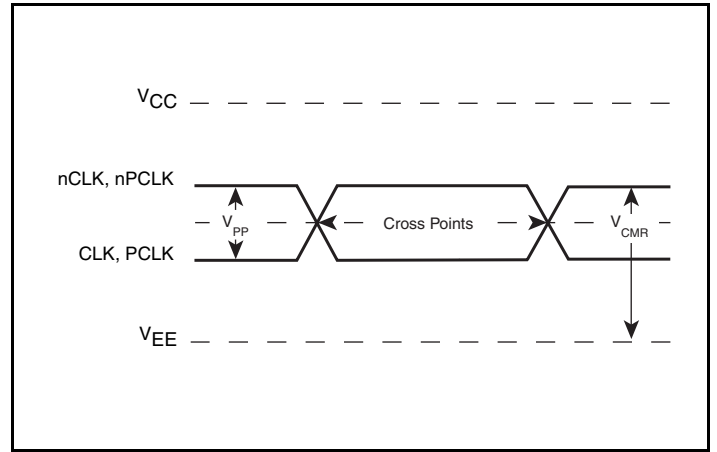

Differential Input Level

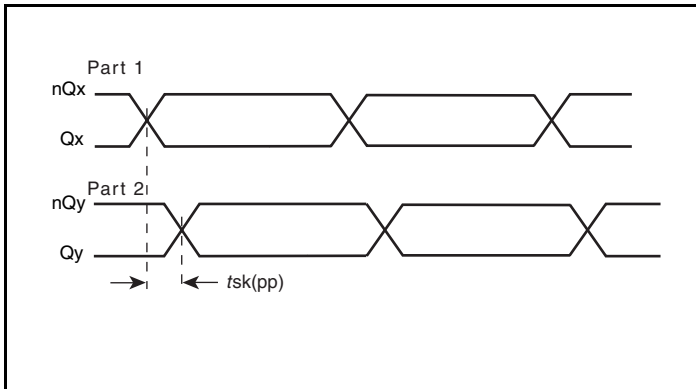

Part-to-Part Skew

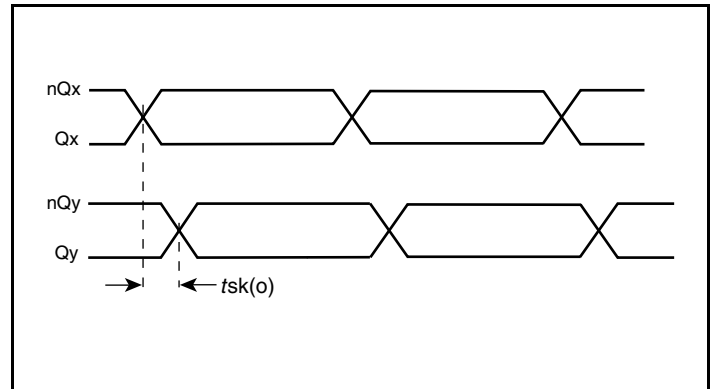

Output Skew

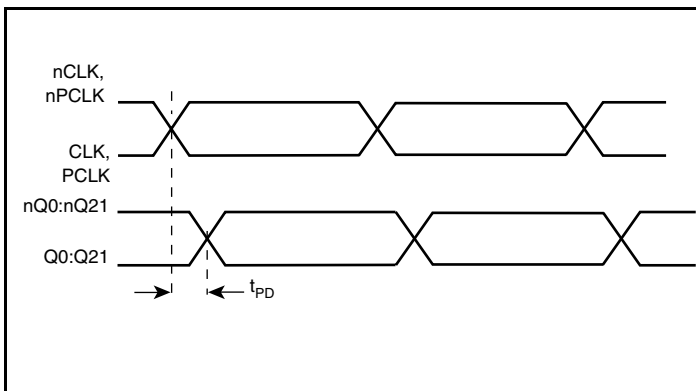

Propagation Delay

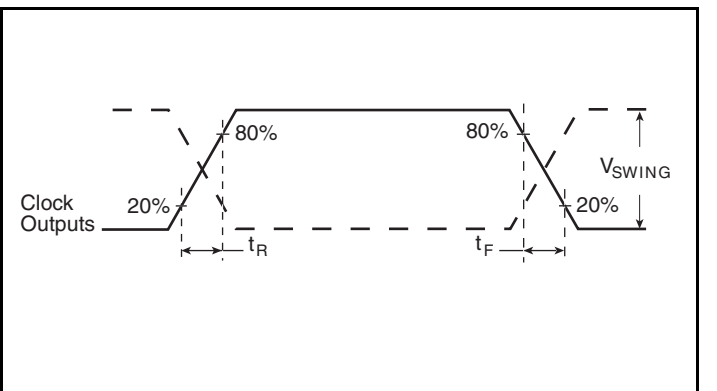

Output Rise/Fall Time



## Parameter Measurement Information, continued

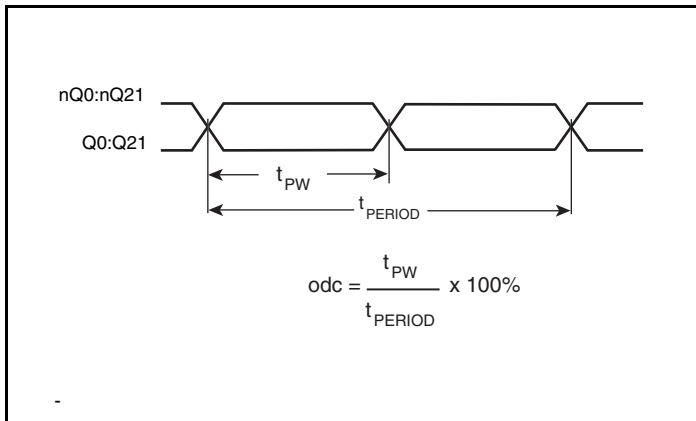

### Output Duty Cycle/Pulse Width/Period

## Applications Information

### Recommendations for Unused Input and Output Pins

#### Inputs:

##### CLK/nCLK<sup>̄</sup>Inputs

For applications not requiring the use of the differential input, both CLK and nCLK can be left floating. Though not required, but for additional protection, a 1k $\Omega$  resistor can be tied from CLK to ground.

##### PCLK/nPCLK<sup>̄</sup>Inputs

For applications not requiring the use of the differential input, both PCLK and nPCLK can be left floating. Though not required, but for additional protection, a 1k $\Omega$  resistor can be tied from PCLK to ground.

##### LVC MOS Control Pins

All control pins have internal pull-ups or pull-downs; additional resistance is not required but can be added for additional protection. A 1k $\Omega$  resistor can be used.

#### Outputs:

##### LVPECL Outputs

All unused LVPECL outputs can be left floating. We recommend that there is no trace attached. Both sides of the differential output pair should either be left floating or terminated.

## Wiring the Differential Input to Accept Single-Ended Levels

Figure 2 shows how a differential input can be wired to accept single ended levels. The reference voltage  $V_{REF} = V_{CC}/2$  is generated by the bias resistors R1 and R2. The bypass capacitor (C1) is used to help filter noise on the DC bias. This bias circuit should be located as close to the input pin as possible. The ratio of R1 and R2 might need to be adjusted to position the  $V_{REF}$  in the center of the input voltage swing. For example, if the input clock swing is 2.5V and  $V_{CC} = 3.3V$ , R1 and R2 value should be adjusted to set  $V_{REF}$  at 1.25V. The values below are for when both the single ended swing and  $V_{CC}$  are at the same voltage. This configuration requires that the sum of the output impedance of the driver ( $R_o$ ) and the series resistance ( $R_s$ ) equals the transmission line impedance. In addition, matched termination at the input will attenuate the signal in half. This can be done in one of two ways. First, R3 and R4 in parallel should equal the transmission

line impedance. For most 50Ω applications, R3 and R4 can be 100Ω. The values of the resistors can be increased to reduce the loading for slower and weaker LVCMOS driver. When using single-ended signaling, the noise rejection benefits of differential signaling are reduced. Even though the differential input can handle full rail LVCMOS signaling, it is recommended that the amplitude be reduced. The datasheet specifies a lower differential amplitude, however this only applies to differential signals. For single-ended applications, the swing can be larger, however  $V_{IL}$  cannot be less than -0.3V and  $V_{IH}$  cannot be more than  $V_{CC} + 0.3V$ . Though some of the recommended components might not be used, the pads should be placed in the layout. They can be utilized for debugging purposes. The datasheet specifications are characterized and guaranteed by using a differential signal.

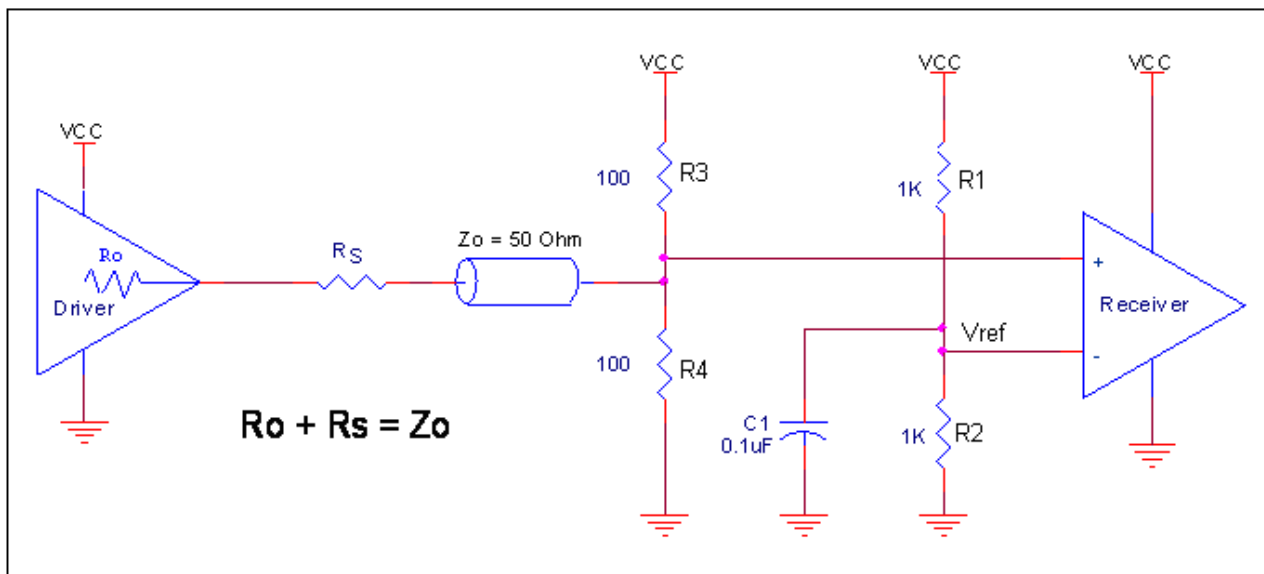

Figure 2. Recommended Schematic for Wiring a Differential Input to Accept Single-ended Levels

### Differential Clock Input Interface

The CLK /nCLK accepts LVPECL, LVDS, HCSL, SSTL, LVHSTL and other differential signals. Both  $V_{SWING}$  and  $V_{OH}$  must meet the  $V_{PP}$  and  $V_{CMR}$  input requirements. Figures 3A to 3F show interface examples for the CLK/nCLK input driven by the most common driver

types. The input interfaces suggested here are examples only. If the driver is from another vendor, use their termination recommendation. Please consult with the vendor of the driver component to confirm the driver termination requirements.

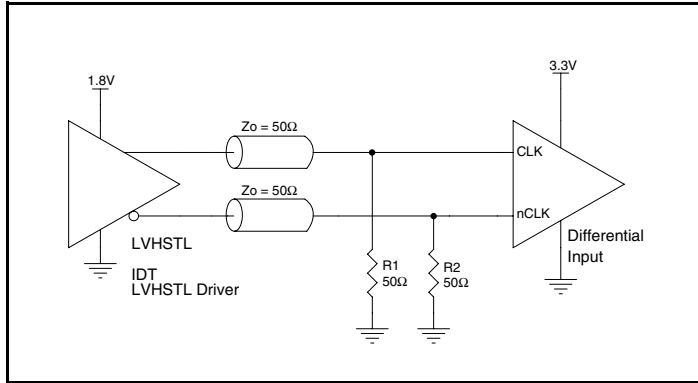

Figure 3A. CLK/nCLK Input Driven by an IDT Open Emitter LVHSTL Driver

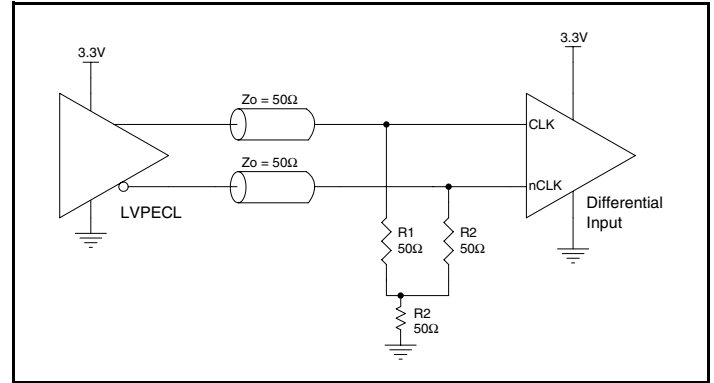

Figure 3B. CLK/nCLK Input Driven by a 3.3V LVPECL Driver

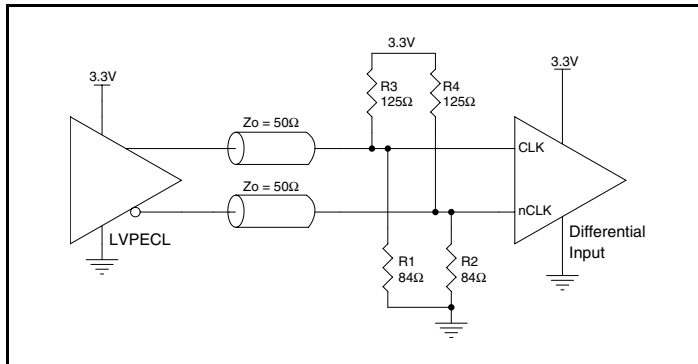

Figure 3C. CLK/nCLK Input Driven by a 3.3V LVPECL Driver

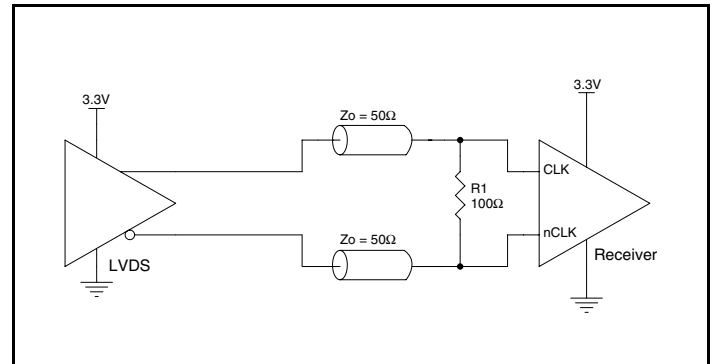

Figure 3D. CLK/nCLK Input Driven by a 3.3V LVDS Driver

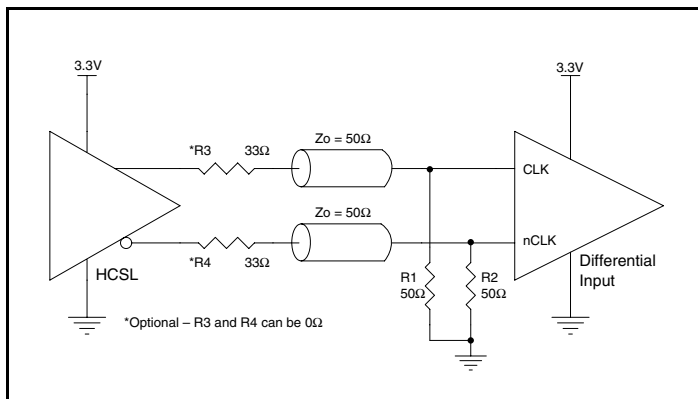

Figure 3E. CLK/nCLK Input Driven by a 3.3V HCSL Driver

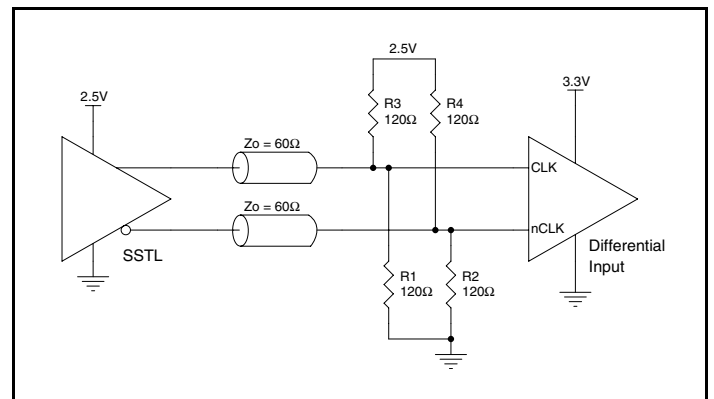
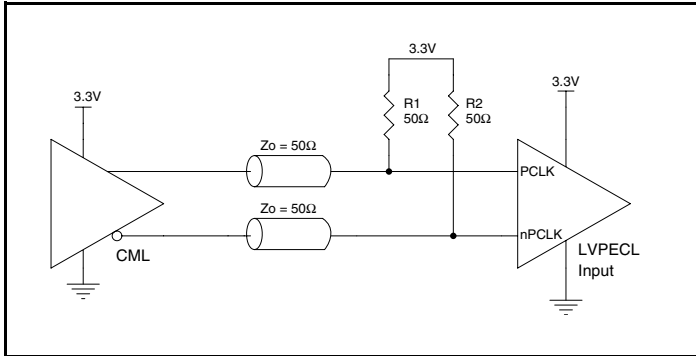

Figure 3F. CLK/nCLK Input Driven by a 2.5V SSTL Driver

## LVPECL Clock Input Interface

The PCLK /nPCLK accepts LVPECL, CML, SSTL and other differential signals. Both  $V_{SWING}$  and  $V_{OH}$  must meet the  $V_{PP}$  and  $V_{CMR}$  input requirements. Figures 4A to 4E show interface examples for the PCLK/nPCLK input driven by the most common driver types.

The input interfaces suggested here are examples only. If the driver is from another vendor, use their termination recommendation. Please consult with the vendor of the driver component to confirm the driver termination requirements.



**Figure 4A. PCLK/nPCLK Input Driven by an Open Collector CML Driver**

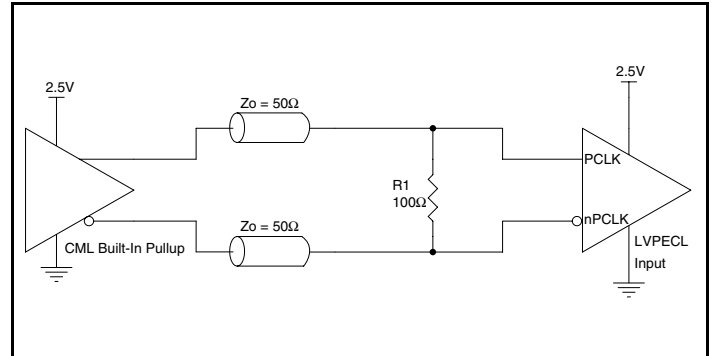

**Figure 4B. PCLK/nPCLK Input Driven by a Built-In Pullup CML Driver**

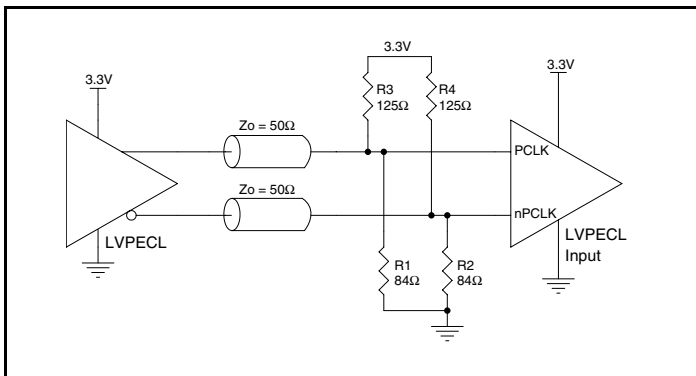

**Figure 4C. PCLK/nPCLK Input Driven by a 3.3V LVPECL Driver**

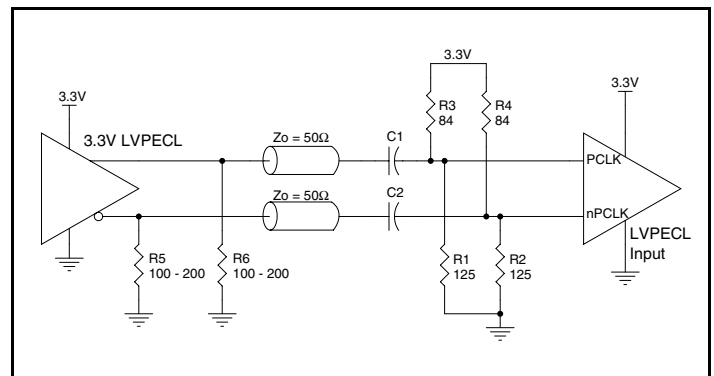

**Figure 4D. PCLK/nPCLK Input Driven by a 3.3V LVPECL Driver with AC Couple**

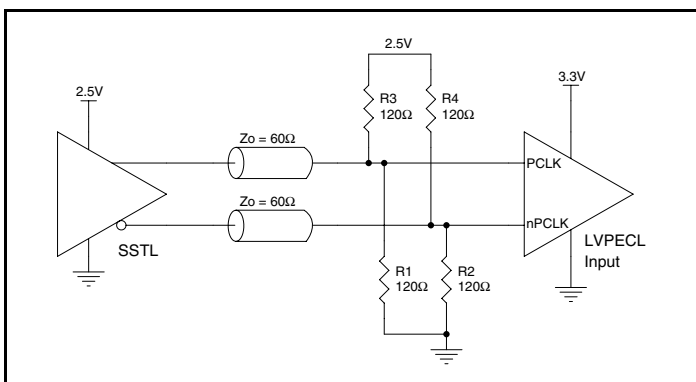

**Figure 4E. PCLK/nPCLK Input Driven by an SSTL Driver**

## Termination for 3.3V LVPECL Outputs

The clock layout topology shown below is a typical termination for LVPECL outputs. The two different layouts mentioned are recommended only as guidelines.

The differential outputs are low impedance follower outputs that generate ECL/LVPECL compatible outputs. Therefore, terminating resistors (DC current path to ground) or current sources must be used for functionality. These outputs are designed to drive  $50\Omega$

transmission lines. Matched impedance techniques should be used to maximize operating frequency and minimize signal distortion.

*Figures 5A and 5B* show two different layouts which are recommended only as guidelines. Other suitable clock layouts may exist and it would be recommended that the board designers simulate to guarantee compatibility across all printed circuit and clock component process variations.

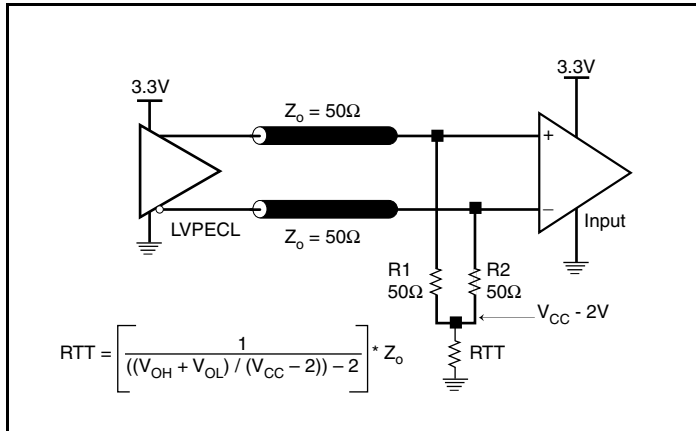

Figure 5A. 3.3V LVPECL Output Termination

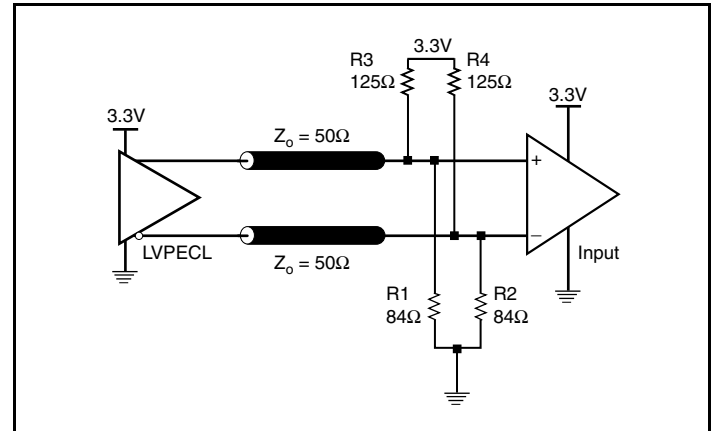

Figure 5B. 3.3V LVPECL Output Termination

## EPAD Thermal Release Path

In order to maximize both the removal of heat from the package and the electrical performance, a land pattern must be incorporated on the Printed Circuit Board (PCB) within the footprint of the package corresponding to the exposed metal pad or exposed heat slug on the package, as shown in *Figure 6*. The solderable area on the PCB, as defined by the solder mask, should be at least the same size/shape as the exposed pad/slug area on the package to maximize the thermal/electrical performance. Sufficient clearance should be designed on the PCB between the outer edges of the land pattern and the inner edges of pad pattern for the leads to avoid any shorts.

While the land pattern on the PCB provides a means of heat transfer and electrical grounding from the package to the board through a solder joint, thermal vias are necessary to effectively conduct from the surface of the PCB to the ground plane(s). The land pattern must be connected to ground through these vias. The vias act as “heat pipes”. The number of vias (i.e. “heat pipes”) are application specific

and dependent upon the package power dissipation as well as electrical conductivity requirements. Thus, thermal and electrical analysis and/or testing are recommended to determine the minimum number needed. Maximum thermal and electrical performance is achieved when an array of vias is incorporated in the land pattern. It is recommended to use as many vias connected to ground as possible. It is also recommended that the via diameter should be 12 to 13mils (0.30 to 0.33mm) with 1oz copper via barrel plating. This is desirable to avoid any solder wicking inside the via during the soldering process which may result in voids in solder between the exposed pad/slug and the thermal land. Precautions should be taken to eliminate any solder voids between the exposed heat slug and the land pattern. Note: These recommendations are to be used as a guideline only. For further information, refer to the Application Note on the *Surface Mount Assembly* of Amkor’s Thermally/Electrically Enhance Leadframe Base Package, Amkor Technology.

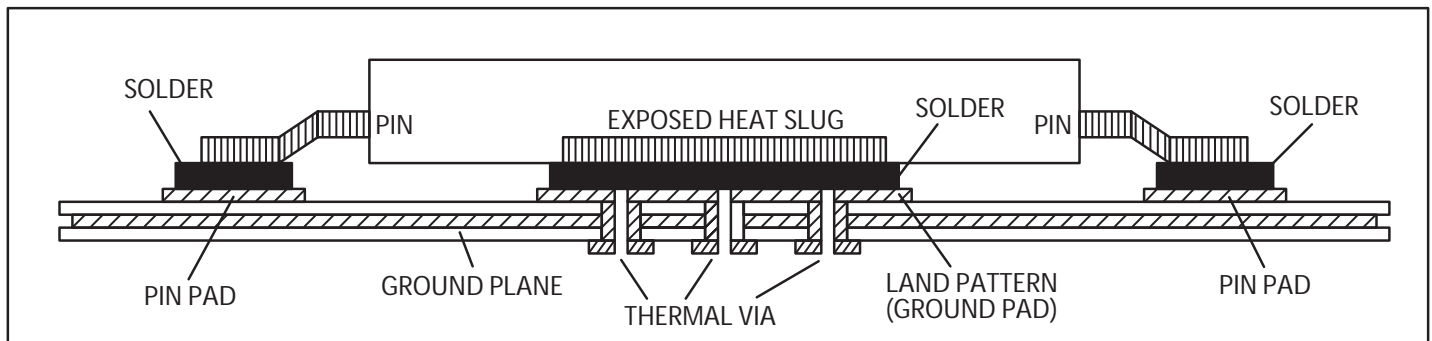

**Figure 6. Assembly for Exposed Pad Thermal Release Path - Side View (drawing not to scale)**

## Power Considerations

This section provides information on power dissipation and junction temperature for the ICS8534-01. Equations and example calculations are also provided.

### 1. Power Dissipation.

The total power dissipation for the ICS8534-01 is the sum of the core power plus the power dissipated in the load(s). The following is the power dissipation for  $V_{CC} = 3.465V$ , which gives worst case results.

NOTE: Please refer to Section 3 for details on calculating power dissipated in the load.

- Power (core)<sub>MAX</sub> =  $V_{CC\_MAX} * I_{EE\_MAX} = 3.465V * 230mA = 796.95mW$
- Power (outputs)<sub>MAX</sub> = **30mW/Loaded Output pair**  
If all outputs are loaded, the total power is  $22 * 30mW = 660mW$

**Total Power**<sub>MAX</sub> (3.465V, with all outputs switching) =  $796.95mW + 660mW = 1456.95mW$

### 2. Junction Temperature.

Junction temperature,  $T_j$ , is the temperature at the junction of the bond wire and bond pad directly affects the reliability of the device. The maximum recommended junction temperature is 125°C. Limiting the internal transistor junction temperature,  $T_j$ , to 125°C ensures that the bond wire and bond pad temperature remains below 125°C.

The equation for  $T_j$  is as follows:  $T_j = \theta_{JA} * Pd\_total + T_A$

$T_j$  = Junction Temperature

$\theta_{JA}$  = Junction-to-Ambient Thermal Resistance

$Pd\_total$  = Total Device Power Dissipation (example calculation is in section 1 above)

$T_A$  = Ambient Temperature

In order to calculate junction temperature, the appropriate junction-to-ambient thermal resistance  $\theta_{JA}$  must be used. Assuming a moderate air flow of 200 linear feet per minute and a multi-layer board, the appropriate value is 17.2°C/W per Table 6 below.

Therefore,  $T_j$  for an ambient temperature of 85°C with all outputs switching is:

$$85^\circ C + 1.457W * 17.2^\circ C/W = 110.1^\circ C. \text{ This is below the limit of } 125^\circ C.$$

This calculation is only an example.  $T_j$  will obviously vary depending on the number of loaded outputs, supply voltage, air flow and the type of board (multi-layer).

**Table 6. Thermal Resistance  $\theta_{JA}$  for 64 Lead TQFP, Forced Convection**

| Linear Feet per Minute                      | $\theta_{JA}$ by Velocity |          |          |
|---|---------------------------|----------|----------|
|   | 0                         | 200      | 500      |
| Multi-Layer PCB, JEDEC Standard Test Boards | 22.3°C/W                  | 17.2°C/W | 15.1°C/W |

### 3. Calculations and Equations.

The purpose of this section is to calculate the power dissipation for the LVPECL output pair.

LVPECL output driver circuit and termination are shown in *Figure 7*.

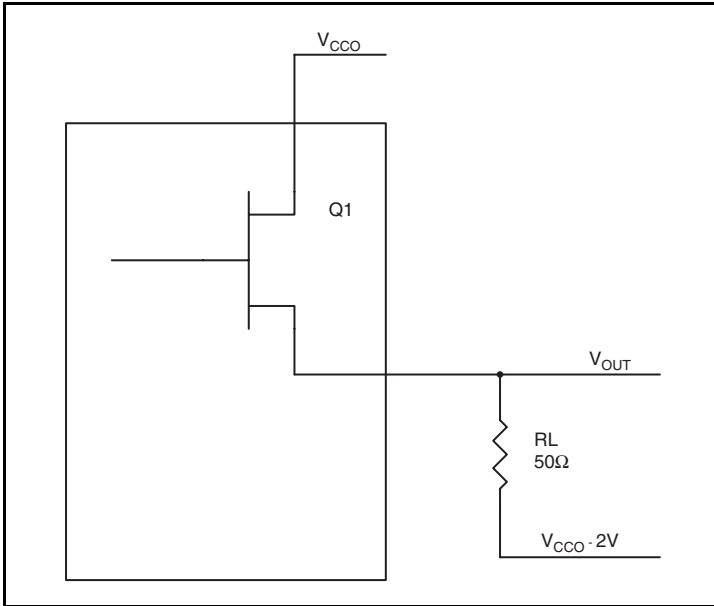

**Figure 7. LVPECL Driver Circuit and Termination**

To calculate worst case power dissipation into the load, use the following equations which assume a 50Ω load, and a termination voltage of  $V_{CCO} - 2V$ .

- For logic high,  $V_{OUT} = V_{OH\_MAX} = V_{CCO\_MAX} - 0.9V$   
( $V_{CCO\_MAX} - V_{OH\_MAX}$ ) = **0.9V**
- For logic low,  $V_{OUT} = V_{OL\_MAX} = V_{CCO\_MAX} - 1.7V$   
( $V_{CCO\_MAX} - V_{OL\_MAX}$ ) = **1.7V**

$Pd\_H$  is power dissipation when the output drives high.

$Pd\_L$  is the power dissipation when the output drives low.

$$Pd\_H = [(V_{OH\_MAX} - (V_{CCO\_MAX} - 2V))/R_L] * (V_{CCO\_MAX} - V_{OH\_MAX}) = [(2V - (V_{CCO\_MAX} - V_{OH\_MAX}))/R_L] * (V_{CCO\_MAX} - V_{OH\_MAX}) = [(2V - 0.9V)/50\Omega] * 0.9V = \mathbf{19.8mW}$$

$$Pd\_L = [(V_{OL\_MAX} - (V_{CCO\_MAX} - 2V))/R_L] * (V_{CCO\_MAX} - V_{OL\_MAX}) = [(2V - (V_{CCO\_MAX} - V_{OL\_MAX}))/R_L] * (V_{CCO\_MAX} - V_{OL\_MAX}) = [(2V - 1.7V)/50\Omega] * 1.7V = \mathbf{10.2mW}$$

Total Power Dissipation per output pair =  $Pd\_H + Pd\_L = \mathbf{30mW}$



## Reliability Information

Table 7.  $\theta_{JA}$  vs. Air Flow Table for a 64 Lead TQFP, E-Pad

| $\theta_{JA}$ vs. Air Flow                  |          |          |          |
|---|----------|----------|----------|
| Linear Feet per Minute                      | 0        | 200      | 500      |
| Multi-Layer PCB, JEDEC Standard Test Boards | 22.3°C/W | 17.2°C/W | 15.1°C/W |

## Transistor Count

The transistor count for ICS8534-01 is: 1474

## Package Outline and Package Dimensions

### Package Outline - Y Suffix for 64 Lead TQFP, E-Pad

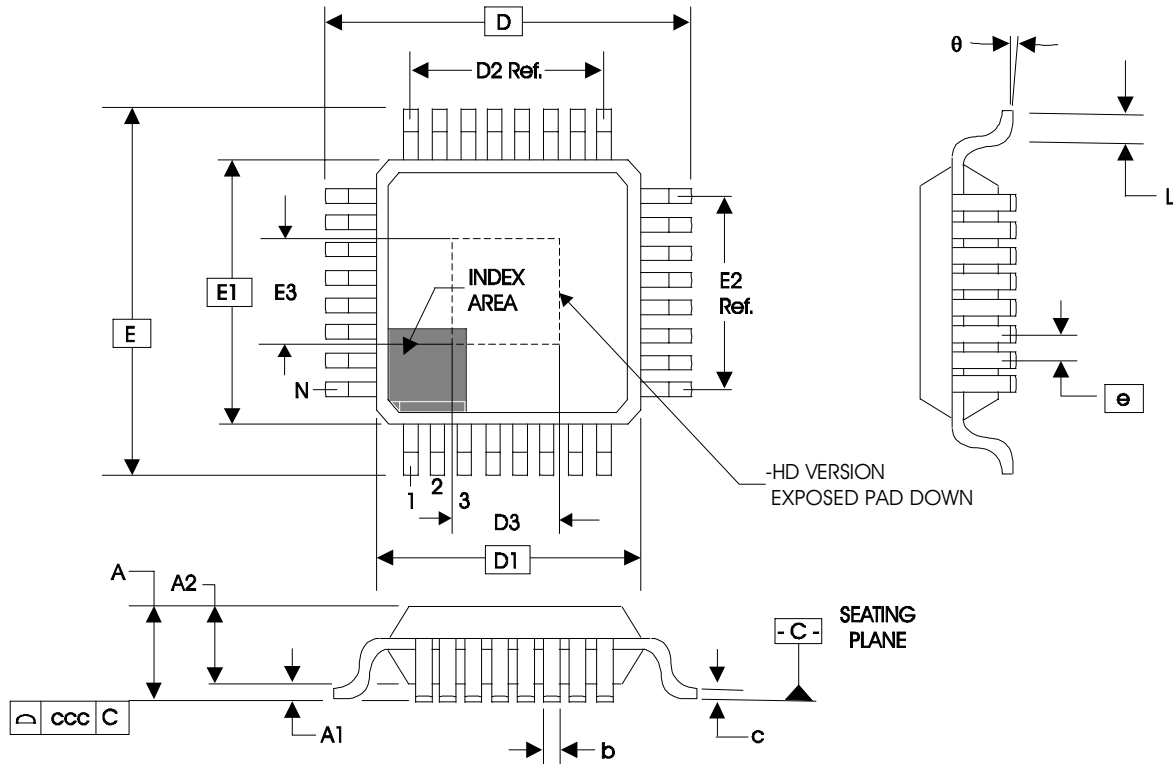

Table 8. Package Dimensions for 64 Lead TQFP, E-Pad

| JEDEC Variation: ACD          |             |         |         |
|-------------------------------|-------------|---------|---------|
| All Dimensions in Millimeters |             |         |         |
| Symbol                        | Minimum     | Nominal | Maximum |
| <b>N</b>                      | 64          |         |         |
| <b>A</b>                      |             |         | 1.20    |
| <b>A1</b>                     | 0.05        | 0.10    | 0.15    |
| <b>A2</b>                     | 0.95        | 1.00    | 1.05    |
| <b>b</b>                      | 0.17        | 0.22    | 0.27    |
| <b>c</b>                      | 0.09        |         | 0.20    |
| <b>D &amp; E</b>              | 12.00 Basic |         |         |
| <b>D1 &amp; E1</b>            | 10.00 Basic |         |         |
| <b>D2 &amp; E2</b>            | 7.50 Ref.   |         |         |
| <b>D3 &amp; E3</b>            | 4.5         | 5.0     | 5.5     |
| <b>e</b>                      | 0.50 Basic  |         |         |
| <b>L</b>                      | 0.45        | 0.60    | 0.75    |
| <b>θ</b>                      | 0°          |         | 7°      |
| <b>ccc</b>                    |             |         | 0.08    |

Reference Document: JEDEC Publication 95, MS-026

## Ordering Information

Table 9. Ordering Information

| Part/Order Number | Marking        | Package                  | Shipping Packaging | Temperature  |
|-------------------|----------------|--------------------------|--------------------|--------------|
| 8534AY-01         | ICS8534AY-01   | 64 Lead TQFP             | Tray               | 0°C to +85°C |
| 8534AY-01T        | ICS8534AY-01   | 64 Lead TQFP             | 500 Tape & Reel    | 0°C to +85°C |
| 8534AY-01LF       | ICS8534AY-01LF | "Lead-Free" 64 Lead TQFP | Tray               | 0°C to +85°C |
| 8534AY-01LFT      | ICS8534AY-01LF | "Lead-Free" 64 Lead TQFP | 500 Tape & Reel    | 0°C to +85°C |

NOTE: Parts that are ordered with an "LF" suffix to the part number are the Pb-Free configuration and are RoHS compliant.

While the information presented herein has been checked for both accuracy and reliability, Integrated Device Technology (IDT) assumes no responsibility for either its use or for the infringement of any patents or other rights of third parties, which would result from its use. No other circuits, patents, or licenses are implied. This product is intended for use in normal commercial applications. Any other applications, such as those requiring extended temperature ranges, high reliability or other extraordinary environmental requirements are not recommended without additional processing by IDT. IDT reserves the right to change any circuitry or specifications without notice. IDT does not authorize or warrant any IDT product for use in life support devices or critical medical instruments.

## Revision History Sheet

| Rev | Table           | Page                                   | Description of Change  | Date     |
|-----|-----------------|--|--|----------|
| A   |                 | 15                                     | Updated Package Outline and Package Dimensions.  | 11/19/04 |
| A   | T9              | 1<br>12<br>13<br>18                    | Features Section - added lead-free bullet.<br>Added <i>Recommendations for Unused Input and Output Pins</i> section.<br>Updated <i>EPad Thermal Release Path</i> section.<br>Ordering Information Table. Added lead-free part number, marking and note.<br>Updated format throughout the datasheet.  | 12/06/07 |
| A   |                 | 1                                      | Pin Assignment - rotated pin orientation 90° back to original orientation, (datasheet publication dated December 6, 2007).   | 5/09/08  |
| B   | T1<br>T4C<br>T6 | 1<br>2<br>5<br>6<br>10<br><br>11<br>12 | Features section, change Additive Phase Jitter spec to 0.15ps typical.<br>Pin Description Table - corrected nQ0, Q0 numbering to 62, 63.<br>LVPECL DC Characteristics Table - corrected notes.<br>AC Characteristics Table - corrected Additive Phase Jitter spec to 0.15ps typical.<br>Updated <i>Wiring the Differential Input to Accept Single-ended Levels</i> application note.<br>Corrected Differential Clock Input Interface Application note.<br>Corrected LVPECL Clock Input Interface Application note.<br>Updated to new header/footer format. | 3/28/11  |
|     |                 |  |  |          |

## We've Got Your Timing Solution



6024 Silver Creek Valley Road  
San Jose, California 95138

**Sales**  
800-345-7015 (inside USA)  
+408-284-8200 (outside USA)  
Fax: 408-284-2775  
[www.IDT.com/go/contactIDT](http://www.IDT.com/go/contactIDT)

**Technical Support**  
[netcom@idt.com](mailto:netcom@idt.com)  
+480-763-2056

DISCLAIMER Integrated Device Technology, Inc. (IDT) and its subsidiaries reserve the right to modify the products and/or specifications described herein at any time and at IDT's sole discretion. All information in this document, including descriptions of product features and performance, is subject to change without notice. Performance specifications and the operating parameters of the described products are determined in the independent state and are not guaranteed to perform the same way when installed in customer products. The information contained herein is provided without representation or warranty of any kind, whether express or implied, including, but not limited to, the suitability of IDT's products for any particular purpose, an implied warranty of merchantability, or non-infringement of the intellectual property rights of others. This document is presented only as a guide and does not convey any license under intellectual property rights of IDT or any third parties.

IDT's products are not intended for use in life support systems or similar devices where the failure or malfunction of an IDT product can be reasonably expected to significantly affect the health or safety of users. Anyone using an IDT product in such a manner does so at their own risk, absent an express, written agreement by IDT.

Integrated Device Technology, IDT and the IDT logo are registered trademarks of IDT. Other trademarks and service marks used herein, including protected names, logos and designs, are the property of IDT or their respective third party owners.

Copyright 2011. All rights reserved.